



AES 7067 IntelliTap-II Digital Dialer Interface

A Supplemental Alarm Reporting Device

PHYSICAL INSTALLATION

- The 7067 IntelliTap-II is mounted inside the AES Subscriber Unit.

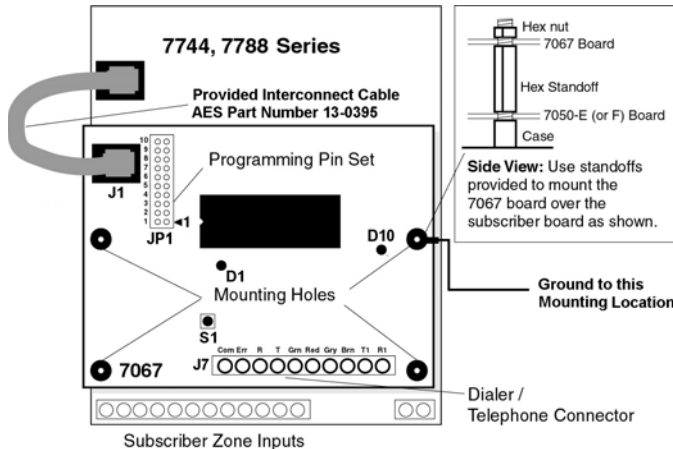

Figure 1: Installation into 7744 and 7788 Series

PHYSICAL INSTALLATION of 7067 in an AES Subscriber Unit

The Tap is installed inside the subscriber unit.

For 7744, 7788 or 7750-F Subscriber Unit: See Figure 1

- Remove four (4) lower nuts holding main board inside box. Save the nuts.
- Install 4 standoffs (provided) in place of nuts, securing the subscriber unit circuit board and providing a mount for the "TAP". Do not overtighten.
- Mount TAP board on standoffs. Secure the board with the 4 nuts removed earlier.
- Earth ground to be connected to right center mounting screw identified with a green hex nut.
- Install 6 wire modular cord between Tap and subscriber main board.

NOTE: The 7067 IntelliTap-II must be mounted inside the subscriber's enclosure. Control Panel dry contact available relays for Alarm, Trouble, Supervision and Delayed Trouble, shall be connected to Subscriber zone inputs using the AES EOL resistors. The use of subscriber zone inputs are required for fire alarm and UL installations as the 7067 IntelliTap is Listed for supplemental alarm reporting only.

SPECIFICATIONS

I/O - Connections:

- J1 – RS-232 data link to AES Subscriber Board, Not Supervised
- J7 – Telephone Line, Alarm Panel Dialer and House Phone Connection Terminal Block, Not Supervised. Wire size 14-22 Gauge

Indicators:

- D10 – Green LED, Illuminated steady when phone line relay is engaged
- D1 – Red LED - Status, Blink = Normal; Steady = Error
Not illuminated when receiving call, then blinks during data transfer

Switches:

- S1 – Reset Switch, restarts IntelliTap Program
- JP1 – Programming Jumpers, 10 positions

Formats Supported

- Contact ID / Point ID
- 3+1, 4+1, 4+2

AES CORPORATION

285 Newbury Street • Peabody, Massachusetts 01960 USA
Tel (978) 535-7310 • Fax (978) 535-7313
www.aes-intellinet.com



OVERVIEW

The AES Model 7067 IntelliTap-II (also referred to as TAP) is a supplemental alarm reporting interface for an AES Subscriber Unit. The Tap II can control an attached incoming telephone line, and provides phone line simulation for maximum alarm panel compatibility. A 7067 retrieves panel data in Contact ID or 4+2 formats from the built-in communicator of an alarm panel. The TAP imitates a digital receiver and gives the proper responses to the alarm panel. The alarm panel only has to tone dial a selected phone number for the TAP to respond and receive the event. The TAP forwards the dialer data to the central station through an AES•IntelliNet Radio Data Network. The IntelliTap II is UL listed as a supplemental reporting device only.

More Features

- Use with or without a phone line attached.
- Telephone Line Cut Detection:** The TAP can monitor for telephone line cuts. In the event of a line cut or connection without a phone line, the Tap will simulate line voltage and dial tone so that the panel can convey alarm data to the AES subscriber unit in the event of an alarm.
- Alternate Reporting Trigger -** The Tap has an Err relay output to annunciate if the radio subscriber unit is off the network. Err output not approved for us in UL or Fire Alarm installations.

COMPATIBILITY

Alarm Panel Compatibility: The TAP works with an alarm panel's digital communicator or dialer output that is programmable for either 3+1, 4+1, 4+2, Contact ID or Point ID formats, with tone dialing capability. In a line cut situation, the Subscriber ID number is used in the Line Cut Message rather than the account number assigned in the Alarm Panel's dialer programming.

Radio Subscriber Unit Compatibility: The TAP is an accessory for the AES IntelliTap ready Radio Subscriber Units. This includes models 7744F and 7788F. Contact AES for compatibility of your Subscriber.

Central Receiver Compatibility: The MultiNet 7705i receiver is compatible with messages created by the addition of an IntelliTap to an alarm panel. In addition for backward compatibility, the 7701 with Net77 software, 7703, and Keltron RF7300 receivers will accept IntelliTap packets. Also for backward compatibility, some earlier model receivers may require an upgrade. Contact AES for compatibility of your receiver. Note that the receiver's automation output sends dialer information from the alarm panel, including the alarm panel ID number. In a line cut the Subscriber ID number is used.

Note: The automation output will send Contact ID information from the alarm panel, including the panel ID number. The AES Subscriber Unit's ID is used in a line cut message detected by the TAP.

Mounting: • Inside subscriber enclosure on provided standoffs

Size: • 5.0" X 3.75" (12.7 X 9.5cm)

Environment:

- Indoor – Dry locations
- Operating Temperature Range: 0° to 49° C (32° to 120°F)
- Storage Temperature Range: -10° to 60° C (14° to 140°F)
- Relative Humidity Range: 0 to 85% RHC, Non Condensing

Power Requirements:

- Voltage – 12 Volts DC nominal
- Current – 50mA

Battery Backup: • Provided and supervised by AES Subscriber Unit

- The TAP shall be installed in accordance with NFPA 72, NEC, UL 864 and all applicable local codes

WARNING: Test this system periodically for proper operation. AES assumes no responsibility for this equipment's failure to operate. AES's sole responsibility is to repair or replace any AES device found to be defective during the warranty period.

**Figure 2:
Component
Locations**

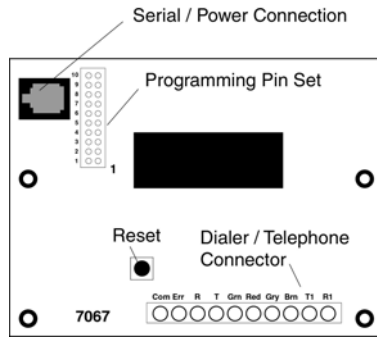

DIALER FORMAT SELECTION -

Jumper Positions 1, 2, 3.

See Figure 2 and 3

IMPORTANT NOTE: The central receiver offers Radionics 6500 and Ademco 685 outputs for automation. If you wish to use the Contact ID format for the AES-IntelliTap, it is strongly recommended that you use the Ademco 685 format for the alarm automation output from your AES receiver.

A single jumper MUST be installed on position 1, 2 or 3

- Contact ID (CID) format = Jumper on 1 only
- 3+1, 4+1, 4+2 format with 1400 Hz answer tone = Jumper on 2 only
- 3+1, 4+1, 4+2 format with 2300 Hz answer tone = Jumper on 3 only

Note: For 3+1, 4+1, 4+2, program your alarm panel for a "single line" data format, with data range 0-9, B-F.

IMPORTANT: Alarm Panel MUST be programmed for TONE dialing only.

Program the alarm panel to dial with matching parameters.

How it Works: The TAP tries other answer tones if the selected format does not produce a response from the alarm panel:

- If 1400 Hz is selected, then 2300 Hz will also be attempted.
- If 2300 Hz is selected, then 1400 Hz will also be attempted.
- If Contact ID (CID) is selected, CID answer tones are tried 4 times, then both 2300 Hz and 1400 Hz are attempted.

NOTE: The Tap will accept signals from the alarm panel ONLY if the Subscriber Unit is enrolled in the network, and has available space in its memory to accept the signal from the Tap.

PROGRAM PHONE NUMBER INTO THE TAP AND ALARM PANEL - Jumper Position 5. - Refer to Figures 2 + 3

Select Phone Number and Program Alarm Panel

You must select which phone number the TAP-II is to respond to. Select either (3-5-*) or (5-5-5). **With no phone line, best to use 5-5-5.**

Program "3-5-*" telephone number - Factory default setting, (preferred setup with phone line) Install jumper on position 5. Program the alarm panel to dial 3-5-*. (Refer to alarm panel manual for how to enter a * "star" character).

Program "5-5-5" telephone number - (Preferred with no phone line) Remove jumper on position 5. Program the alarm panel dialer phone number with the digits 5-5-5. During a reported event, if the phone line is quiet after the 5-5-5 is dialed, the TAP provides an answer tone, signalling to the alarm panel to transmit its data, and then kisses it off. The control panel then hangs up the line. Test the setup - see next page.

Note: Program the alarm panel for Tone/DTMF dialing. Pulse dialing will NOT work.

**Figure 3:
Programming
Jumpers**

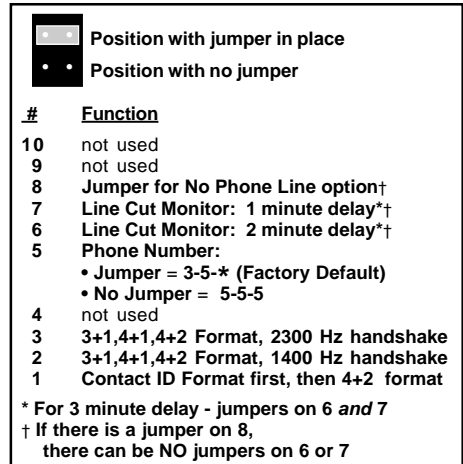

LINE CUT MONITOR PROGRAMMING

Jumper Positions 6, 7, 8.

Refer to Figures 2 + 3

The TAP will detect and report a telephone line cut. The TAP determines that the line is cut when the voltage across terminals Grn and Red drops below approximately 2.5 volts for a programmable period of time. The line cut function is enabled and its parameters are set using jumpers 6, 7 and 8 (see figures 2+3).

- **Line cut monitor:**
 - with 1 minute line cut detect delay = Jumper on 7 only
 - with 2 minute line cut detect delay = Jumper on 6 only
 - with 3 minute line cut detect delay = Jumpers on 6 AND 7
- **No Phone Line Used, and No Line Cut Monitor = Jumper on 8 only** (If there is a jumper on 8, there can be NO jumpers on 6 or 7)
- **Push Reset Switch on 7067 after setting jumpers.**

For installations that do not have a phone line attached, install jumper in position 8 for "No Phone Line option" and no jumper in either position 6 or 7.

"Err" Error / Fault Output -

No Connection - for future use

Figure 4:

Typical Wiring Diagram for Com Error Output

No Connection - for future use



Figure 5:
Typical Wiring Diagram with Phone Line Attached

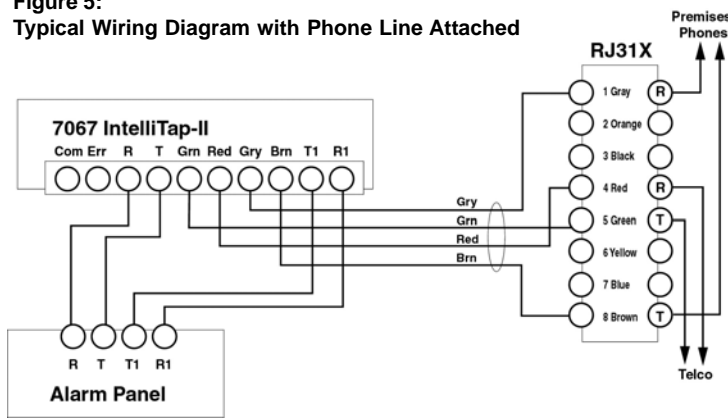

Use a Listed phone cord set with min. 26AWG wire

IMPORTANT: BEFORE TESTING, notify the central station that a test is in progress for this account.

Figure 6:
Typical Wiring Diagram with NO Phone Line Attached

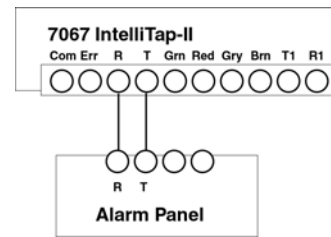

IMPORTANT!

CONNECTION OF ZONES ON THE SUBSCRIBER UNIT:

UL requires connection of available relays to Zones in the Subscriber. At a minimum you must connect the Alarm and Trouble relay outputs to individual zones. If available you must also connect the Supervision and AC Fail Delay relays to their individual zones.

The Tap is a supplemental reporting device.

The activated zone annunciates general Alarm, Trouble or Supervision conditions.

Zone activation is immediate, and will likely activate faster than the TAP, which must wait for the alarm panel's digital dialer to go through its communication process.

Note that the ID of the AES Subscriber Unit will be sent with the zone input signal. The ID programmed into the alarm panel's dialer configuration will be sent with the TAP signal. Those ID's may or may not be the same.

Programming Guide

Jumper positions 1, 2 or 3:

These positions select the answer tone to provide when the IntelliTap answers a call.

Refer to page 2 for detailed instructions on positions 1, 2 & 3.

Warning! A jumper must be placed in one of these positions or the Tap will not answer the call with any answer tone.

Jumper position 4:

This position is not used and is reserved for future use.

Jumper position 5:

This selects the telephone number the IntelliTap II is looking for to initiate an answer and begin communication with the alarm panel. The IntelliTap will answer any phone number with 3 or more digits during a line cut condition.

The selected number **with a jumper** in position 5 is "3 - 5 - * "

The selected number **with no jumper** in 5 is "5 - 5 - 5"

No jumpers in 6, 7 or 8:

Phone simulator never comes on. An attached telephone line is disconnected during communication between panel and Tap, also applying voltage to the panel's phone line connection and disconnecting phone interference. Tap does not send line cut message. It disconnects a connected phone line during communication. Panel must dial the selected Tap number for Tap to answer. IntelliTap II will not respond to just any phone number if the phone line is cut. The panel must be able to blind dial the selected number, hear the answer tone and generate the message.

Note 1: This setting is not a usable option for panels that require a phone line voltage and or dial tone to communicate.

Note 2: This is OK for a panel that will blind-dial without voltage to Ring & Tip.

Jumper in 6, No jumpers in 7, or 8:

A jumper in 6 selects two-minute phone line cut detection. This will introduce the built in phone line simulator when the IntelliTap II detects a voltage below 2.5 volts for 2 minutes on terminals labeled Grn and Red of J3. A line cut message using ID of Subscriber is generated and transmitted to the central receiver. A Restore will occur immediately when voltage returns and will reset the 2 minute phone line cut detection as well as generate and transmit a restore line message to central receiver. During a phone line cut, the Tap will answer any phone number with 3 or more digits dialed by the panel. When the phone line is present, the Tap will only answer the number selected by jumper position 5.

Jumper in 7, No jumpers in 6, or 8:

A jumper in 7 selects one-minute phone line cut detection. This will introduce the built in phone line simulator when the IntelliTap II detects a voltage below 2.5 volts for 1 minute on terminals labeled Red and of J3. A line cut message using ID of Subscriber is generated and transmitted to the central receiver. A Restore will occur immediately when voltage returns and will reset the 1 minute phone line cut detection as well as generate and transmit a restore line message to central receiver. During a phone line cut, the Tap will answer any phone number with 3 or more digits dialed by the panel. When the phone line is present, the Tap will only answer the number selected by jumper position 5.

Jumpers in 6 and 7, No jumpers in 8:

A jumper in 6 and 7 selects three-minute phone line cut detection. This will introduce the built in phone line simulator when the IntelliTap II detects a voltage below 2.5 volts for 3 minutes on terminals labeled Grn and Red of J3. A line cut message using ID of Subscriber is generated and transmitted to the central receiver. A Restore will occur immediately when voltage returns and will reset the 3-minute phone line cut detection as well as generate and transmit a restore line message to central receiver. During a phone line cut, the Tap will answer any phone number with 3 or more digits dialed by the panel. When the phone line is present, the Tap will only answer the number selected by jumper position 5.

JUMPER IN 8, NO JUMPERS IN 6 OR 7:

A jumper in 8 selects no phone line is to be connected. This mode forces a line cut condition, but will not generate line cut/restore messages. This will always introduce the built in phone line simulator. Never connect terminals labeled Grn and Red of J3 to a telephone line. During this forced line cut, the Tap will answer any phone number with 3 or more digits dialed by the panel.

Jumper in 8, any jumper in 6 and or 7: (NOT Permitted)

This setting is not permitted, **DO NOT USE** especially with a phone line connection.

Jumpers in 6 and 7 select phone line cut times and a jumper in 8 selects no phone line. This produces a conflict. The IntelliTap II is not expecting a phone line connection. It causes erratic operation of relays and phone simulator. Line cut and restores are sent erratically.

Jumper position 9:

This position is for debug mode. This is only for use by AES. A jumper in this position may cause the IntelliTap to not function,

Jumper position 10: (not labeled on the board)

This position is not used and is reserved for future use.

TESTPROCEDURE:

- Notify the Central Station that a test is in progress.
- Trip the alarm control panel alarm and trouble circuits.
- Check with the central station that the correct messages were received.

UL Compliance Notes

- The 7067 IntelliTAP unit has been investigated by UL for Supplemental Use Only.
- The 7067 IntelliTAP unit must be mounted inside the AES Subscriber Unit.

The 7067 IntelliTAP unit has been evaluated to the following Standards:

UL:

- UL 365 - Police Station Connected Burglar Alarm Units and Systems
- UL 1610 - Central Station Burglar Alarm Units
- UL 864 - Control Units for Fire-Protective Signaling Systems

FCC IDENTIFICATION AES IntelliTAP-II Model 7067

This unit complies with FCC Part 68 as of date of manufacture. FCC#

51WUSA-32157-SP-N • Ringer Equivalence: 0.5B Jack: Barrier Block

•FCC COMPLIANCE

NOTE: This equipment has been tested and found to comply with the limits for a Class B digital device, pursuant to Part 15 of the FCC Rules. These limits are designed to provide reasonable protection against harmful interference in a residential installation. This equipment generates, uses and can radiate radio frequency energy and, if not installed and used in accordance with the instructions, may cause harmful interference to radio communications. However, there is no guarantee that interference will not occur in a particular installation. If this equipment does cause harmful interference to radio or television reception, which can be determined by turning the equipment off and on, the user is encouraged to try to correct the interference by one or more of the following measures: Reorient or relocate the receiving antenna; Increase the separation between the equipment and the receiver; Connect the equipment into an outlet on a circuit different from that to which the receiver is connected; Consult the dealer or an experienced radio/TV technician for help. CAUTION: Changes or modifications to this equipment not expressly approved by the party responsible for compliance could void the user's authority to operate the equipment.

•CANADIAN COMPLIANCE

This digital apparatus does not exceed the Class B limits for radio noise emissions from digital apparatus as set out in the interference-causing equipment standard entitled "Digital Apparatus", ICES-003 of Industry Canada. Cet appareil numérique respecte les limites de bruits radio électriques applicables aux appareils numériques de Classe B prescrites dans la norme sur le matériel brouilleur: "Appareils Numériques", NMB-003 édictés par l'Industrie Canada.

OWNER WARRANTY - AES CORPORATION

LIMITED PRODUCT WARRANTY AND TECHNOLOGY LICENSE

LIMITED PRODUCT WARRANTY:

AES Corporation ("AES") warrants to the original purchaser that each AES Subscriber Product will be free from defects in material and workmanship for three (3) years from date of purchase and all other products purchased from AES including central station receivers and accessories will be warranted for one (1) year from the date of purchase. At no cost to the original purchaser for parts or labor, AES will repair or replace any AES Product or any, part or parts thereof which are judged defective under the terms of this Warranty.

Defective AES Products must be returned to AES directly, provided they are properly packed, postage prepaid. Or exchange may be made through any authorized direct factory representative for any AES Products that are judged defective under the terms of this Warranty. Improper or incorrectly performed maintenance or repair voids this Warranty. This Warranty does not cover replacement parts that are not approved by AES. This Warranty does not apply to any AES Product or any part thereof that has been altered in any way to affect its stability or reliability, or that has been subjected to abuse, misuse, negligence, accident or act of God, or that has had the serial number effaced or removed.

Certain AES Products are designed to operate and communicate with other specified AES Products and certain other specified products, systems or networks authorized or approved by AES, as identified in the applicable AES Product instructions. This Warranty does not apply to any AES Product that is used with any unauthorized or unapproved products, systems or networks, or that has been installed, applied or used in any manner, other than in strict accordance with AES instructions.

AES makes no warranty, express or implied, other than what is expressly stated in this Warranty. If the law of your state provides that an implied warranty of merchantability, or an implied warranty of fitness for particular purpose, or any other implied warranty, applies to AES, then any such implied warranty is limited to the duration of this Warranty.

AES cannot be aware of and is not responsible for the differing values of any property to be protected by its alarm reporting systems. This Warranty does not cover and AES shall not be liable for any defect, incidental or consequential, loss or damage arising out of the failure of any AES Product to operate.

Some states do not allow the exclusion or limitation of the durations of implied warranties or the limitation on incidental or consequential damages, so the above limitations or exclusions may not apply to you.

This Warranty gives you specific legal rights and you may also have other rights that vary from state to state.

TECHNOLOGY LICENSE:

Certain AES Products include software, protocols and other proprietary and confidential technology and trade secrets of AES which are incorporated in or provided with AES Products solely for use in conjunction with and in order to operate AES Products ("Licensed Technology"). AES grants the original purchaser a non-exclusive license to use such Licensed Technology solely in connection with the use and operation of AES Products and for no other purpose or use whatsoever. No title or ownership in or to any such Licensed Technology is conveyed by the sale or delivery of any AES Products; all such rights are retained by AES.

AES SERVICE PROCEDURE: Contact AES by Phone at (978) 535-7310, Fax (978) 535-7313 or email rma@aes-intellinet.com, to receive a Return Material Authorization Number. Have the AES part number and serial number ready. Repack equipment in original or equivalent packaging. Inside the box, please include a contact name, telephone number, address and a brief description of the reason for return.

Ship items freight-prepaid to:

Repair Services, RMA# _____
 AES Corporation
 285 Newbury Street
 Peabody, MA 01960 USA

(Contact AES for Return Material Authorization number)

June 2007