VANTAGE SERIES

4110
INSTALLATION
INSTRUCTIONS

® ADEMCO

CONGRATULATIONS

on your purchase of the VANTAGE 4110!

The purpose of these Installation Instructions is to give you a brief overview of the VANTAGE 4110 system, and provide instructions for installing a basic system.

As always, ADEMCO is there for YOU! Our SALES and TECHNICAL SUPPORT staff are eager to assist you in any way they can, so don't hesitate to call, for any reason!

East Coast Technical Support: 1-800-645-7492 (8 a.m.-6 p.m. E.S.T.)

West Coast Technical Support: 1-800-458-9469 (8 a.m.-5 p.m. P.S.T.)

PLEASE,

Before you call Technical Support, be sure you have:

- Checked all wiring connections and fuses.
- Determined that the power supply and backup battery are supplying proper voltages.
- Verified your programming information where applicable.
- Noted the proper model number of this product, and the version level (if known) along with any documentation that came with the product.
- Your Ademco customer number and/or company name.

Having this information handy will make it easier for us to serve you quickly and effectively.

Again, CONGRATULATIONS, and WELCOME ABOARD!

FOR YOUR CONVENIENCE, two easily removable Programming Forms have been included at the center of this manual.

This system is not California State Fire Marshall approved and, as such, should not be used for fire protection in California (or other areas requiring such acceptance).

TABLE OF CONTENTS

General Information.....	3	The Limitations of this Alarm System	14
Remote Programming and Control	3	Canadian DOC Statement	15
Zone Types Available for Selection.....	4	FCC Statement.....	16
4-Digit Security Codes	4	Limited Warranty	16
Mounting the Console(s).....	5	Diagrams	
Wiring Connections	6	Installing the Lock (If Used).....	5
Programming the Security Control	7	Installing the 4110 Circuit Board.....	5
Specific Address Programming Instructions.....	8	Summary of Connections.....	6
Testing the System.....	12	Programming Form	10
Accessories	12		
Specifications.....	13		

GENERAL INFORMATION

The VANTAGE (No. 4110) is a microprocessor-based security control which provides up to 6 wired zones. The security control is housed in a wall-mounted metal cabinet measuring 12-1/2" (318mm) wide x 14-1/2" (368mm) high x 3" (76mm) deep, and can be used with a console equipped with a multi-function 12-key digital keypad and a numeric and fixed English status LCD display (4127). Optionally, a No. 4137 may be used or a No. 5330 Alpha Console (select for Vector device, as described in the 5330's installation instructions) may be used with the control to provide programmable English language zone descriptors and status indications. The system may also be armed and disarmed using a keyswitch.

Connections to the security control are made via a 21-terminal connector block which is used to interface to the wired loops, plug-in transformer, telephone line, remote console(s), external alarm sounder(s), etc. The security control can be easily programmed from any of the above remote consoles. Programmed options to establish specific alarm and reporting features are stored in electrically

erasable, non-volatile EEROM memory. This means that the unit can be reprogrammed many times (unlike units equipped with PROMs) and that information which has been programmed will not be lost in the event of a complete loss of power.

The system also provides communication capability (central station reporting, etc.) over existing telephone lines. In addition, it can be uploaded or downloaded via your computer and Hayes Modem.

This system includes an alarm output rated at 2 amps. Throughout the manual, wherever reference is made to Alarm Output Ratings, they assume a fully charged battery is connected unless the UL rating is stated.

Zone Characteristics

Zones 1-6: Programmable Zones, EOLR supervised, N.O. or N.C. sensors, 300-500 msec response.

Zone 3: Fast 10-15 msec response optional.

REMOTE PROGRAMMING AND CONTROL

The No. 4110 can be remotely programmed from an IBM compatible Personal Computer (PC), a Hayes Modem, and using Ademco's V-LINK® Software. Programming the No. 4110 from a remote location is protected against compromise by using multi-levels of security protection:

1. **Security Code Handshake:** An 8-digit download ID code must be matched between the No.4110 and the downloader.
2. **Site Initiated Remote Programming:** The installer or subscriber initiates the callback from the subscriber premises (by pressing MASTER CODE + # + 1). All parameters can then be downloaded via the phone lines using a personal computer.
3. **Data Encryption:** Data passed between the PC and the No. 4110 is encrypted for security so that it is very difficult for a foreign device tapped into the phone line to take over communication and substitute system compromising information.

Equipment Required: 4110 and console (at premises), an IBM PC compatible computer, a Hayes brand Smartmodem 1200 (Level 1.2 or higher external or Level 1.1 or higher internal style), No. 4130PC Downloading Software Diskette (Rev. 1.5 or higher), and appropriate interconnecting cables.

Programming: The system uses only two commands, one for uploading and one for downloading.

Notes: After the 4110 and the PC have established valid communication, each console on the system will become inactive. The consoles will become active after the download communication is terminated. The detailed operation of the download functions is covered in the installation instructions for the 4130PC Download Software Diskette.

Remote Programming Advisory Notes:

- Alarm and Trouble reporting are disabled during the time that the system and the central station are linked to each other following a valid exchange of codes.
- Keypad entries are ignored during the time interval stated above.
- Should an alarm occur during the remote program interval, the system would not respond to the alarm condition.
- A copy of the program downloaded may be produced from the IBM PC compatible computer, using the product's internal report generator, when an optional printer is connected (consult your PC manual for proper printer and connections).
- Program Download Time—Less than 45 seconds for a complete program.

ZONE TYPES AVAILABLE FOR SELECTION

For each zone used, one of the following zone types must be selected:

0. Zone Disabled

1. **Entry/Exit Burglary.** Assigned to sensors on doors through which entry and exit will normally take place when the system is armed.
2. **Supervised Fire With programmable bell timeout.** (alarm on short/trouble on open). Fire zone may not be bypassed. Only usable on Zone 5 or Console Panic.
3. **Perimeter Burglary.** Normally assigned to all sensors on exterior doors and windows requiring instant alarm.
4. **Interior, Follower.** Delayed alarm only if the Entry/Exit zone is faulted first; otherwise, produces an instant alarm. Assigned to zone covering an area such as a foyer or lobby through which one must pass upon entry to reach the keypad to disarm the system. Designed to provide instant intrusion alarm in the event an intruder hides on the premises prior to the system being armed or gains access to the premises through an unprotected area.
5. **Trouble by Day/Alarm by Night.** Can be assigned to a zone which contains a foil-protected door or window (such as in a store), or to a zone covering a "sensitive" area such as a stock room, drug supply room, etc., or other controlled access area where immediate notification of an entry is desired. During the disarmed state (day),

the system will provide latched Console annunciation (and central station report, if desired) of openings or troubles (such as sensor malfunctions or foil breaks). During the armed state (night), violations will initiate an alarm.

6. **24-hour Silent Alarm.** This type generally assigned to a zone containing an Emergency button that is designed to initiate an alarm report to the Central Station, but which produces no local displays or alarm sounds.
7. **24-hour Audible Alarm.** This type also assigned to a zone containing an Emergency button, but which will initiate an audible alarm in addition to an alarm report to the Central Station.
8. **24-hour Auxiliary Alarm (Console sounder only).** This type assigned to a zone containing a button for use in personal emergencies, or to a zone containing monitoring devices such as water sensors, temperature sensors, etc. Designed to initiate an alarm report to the Central Station and only provides Console warning sounds and alarm displays.
9. **Supervised Fire Without programmable bell timeout.** (alarm on short/trouble on open). Fire zone may not be bypassed. Only usable on Zone 5 or Console Panic.

4-DIGIT SECURITY CODES

Master Security Code:

The installer programs the Master Code initially as part of the programming procedure (see "Programming the Security Control"). The Master code permits re-entry into the programming mode and also allows access to the normal functions of the system.

[][][][] Master Code (User #1),
assigned during programming.

Installer exits programming mode with:

- *98 (prevents re-entry into programming mode with Master code).
- *99 (allows re-entry into programming mode with Master code).

By exiting with *98, the only method of getting back into the programming mode from the console is to completely depower the system and follow the procedure noted in the section on "Programming the Security Control".

The Master security code can be used to assign up to three secondary codes; it can also be used to remove all secondary codes from the system (individually).

Secondary Security Codes:

Secondary security codes are assigned by Master Code as follows:

Master Code + CODE key + User # (2 - 4)
+ Secondary Code

The system will emit a single beep when each secondary code has been successfully entered.

Note: When a secondary code is inadvertently repeated for different users, or one user's code is another's duress code, the lower user number will take priority.

Individual secondary security codes can be deleted by user #1 (with Master Code) as follows:

Master Code + CODE key + User # (2 - 4)

Note: All security codes, master and secondary, permit access to the system for arming, disarming, etc.

INSTALLING THE LOCK (IF USED)

(The cabinet can be closed and secured *without* a lock by using 2 screws in the cover's edge.)

Use Ademco No. N6227 Cam Lock and No. N6227-1 Push-On Clip (Retainer Clip).

1. Remove the cabinet cover. *It is easily removable for servicing and is easily reinstalled.*
2. Remove the lock knockout from the control cabinet cover. Insert the key into the lock. Position the lock in the hole making certain that the latch will make contact with the latch bracket when the door is closed.
3. While holding the lock steady, insert the retainer clip into the retainer slots. Position clip as illustrated to facilitate easy removal.

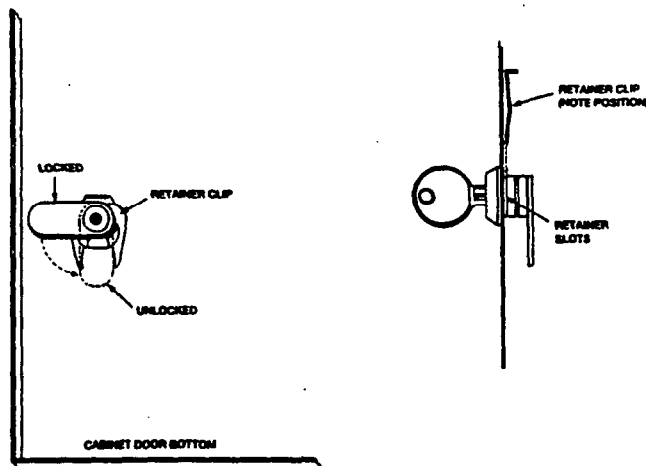

INSTALLING THE 4110 CIRCUIT BOARD

Note: BEFORE MOUNTING THE CIRCUIT BOARD, be sure to remove the appropriate metal knockouts from the cabinet. DO NOT ATTEMPT TO REMOVE THE KNOCKOUTS AFTER THE CIRCUIT BOARD HAS BEEN INSTALLED.

1. Hang two *short* mounting clips (provided) on the raised cabinet tabs (see lower detail side view at right).
2. Insert the top of the circuit board into the slots at the top of the cabinet. Make sure that the board rests on the correct row (see the upper detail side view at right).
3. Swing the base of the board into the mounting clips and secure the board to the cabinet with the accompanying screws (as illustrated in lower detail).

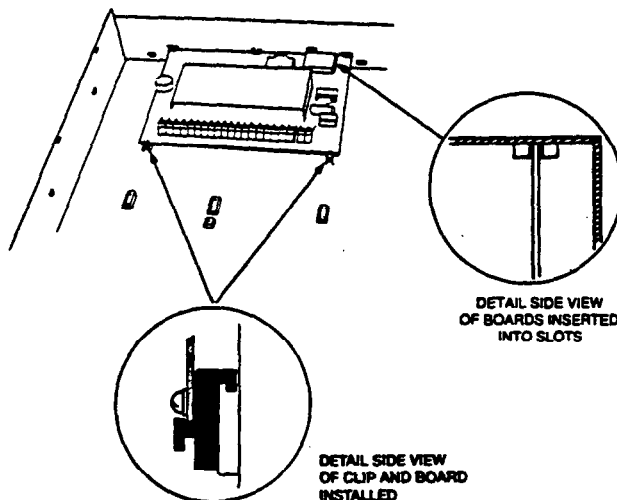

MOUNTING THE 4127 CONSOLE(S)

1. Separate the console from its backplate by removal of the two screws on the top and bottom edges.
2. Use the backplate to mark the positions on the wall for the screw mounting holes and the cut-out for the interface wiring. Use wall anchors for the screws and make the cut-out in the wall no larger than indicated on the template. The backplate is designed to be directly mounted to either a single or double gang electrical box.
3. Pull the interface wiring in the wall through the cut-out.
4. Pass the interface wiring through the opening in the backplate and then mount the backplate to the wall surface with screws.
5. Splice the interface wiring to the console wires. Insulated solderless wire splices (such as Ademco No. 311) may be used for splicing.
6. Attach the main body of the console to the wall-mounted backplate. The console is properly attached when it is screwed to the backplate by top and bottom screws.

WIRING CONNECTIONS

IMPORTANT: Do not connect the battery, or plug in the AC transformer, until all other wiring connections have been completed.

Grounding the System

Terminal 21 is the earth ground connection point. In order for the protective devices in this product to be effective, the designated terminal must be terminated in a good earth ground. The following are examples of good earth grounds available at most installations:

Metal cold water pipe: Use a non-corrosive metal strap firmly secured to the pipe to which the lead is electrically connected and secured.

AC power outlet ground: Available from 3-prong, 120 VAC power outlets only. To test the integrity of the ground terminal, use a 3-wire circuit tester with neon lamp indicators, such as the UL Listed Ideal Model 61-035, or equivalent, available at most electrical supply stores.

TERMINALS

1 & 2: AC Input from No. 1321/TF2 plug-in transformer, in U.S.A. (16.5VAC, 25VA)

NOTE: In Canadian installations, a 1321CN transformer must be used.

3: Alarm relay output(+), 12VDC, 2.0A maximum (600mA max. Alarm plus Aux. Power, for UL usage).

4: Alarm Output / Auxiliary Power / Fire / Console / Optional Keyswitch (BLACK lead) Ground (-) Return.

5: Auxiliary / Fire / Console / Optional Keyswitch (RED) Power: +12VDC at 500mA max. †

6: Data In from Console / Optional Keyswitch (GREEN) †

7: Data Out to Console/Optional Keyswitch (YELLOW) †

8: Zone 1. (When Zones are used, a 1,000 Ohm EOLR should be wired between the farthest sensor connected to the zone terminal and the low side of the zone.)

9-16: Zone wiring and zone returns.

17: Handset (TIP).

18: Handset (RING).

19: Incoming Phone Line (TIP).

20: Incoming Phone Line (RING).

21: EARTH GROUND (a proper earth ground must be provided to protect the system from lightning and electrostatic discharge damage).

WARNING: To prevent risk of electrical shock, disconnect telco jack before servicing unit.

† Multiple consoles may be used, but each Ademco 5330 Console *must* be on an individual home run. Use no more than 220' of #22 wire or 550' of #18 wire.

RED LEAD: Battery(+). When AC is present, 13.8VDC is being developed to recharge a gel lead acid battery and when AC is absent, 12VDC current is drawn from the battery. Battery lead reversal will blow the battery fuse.

BLACK LEAD: Battery (-).

SUMMARY OF CONNECTIONS DIAGRAM

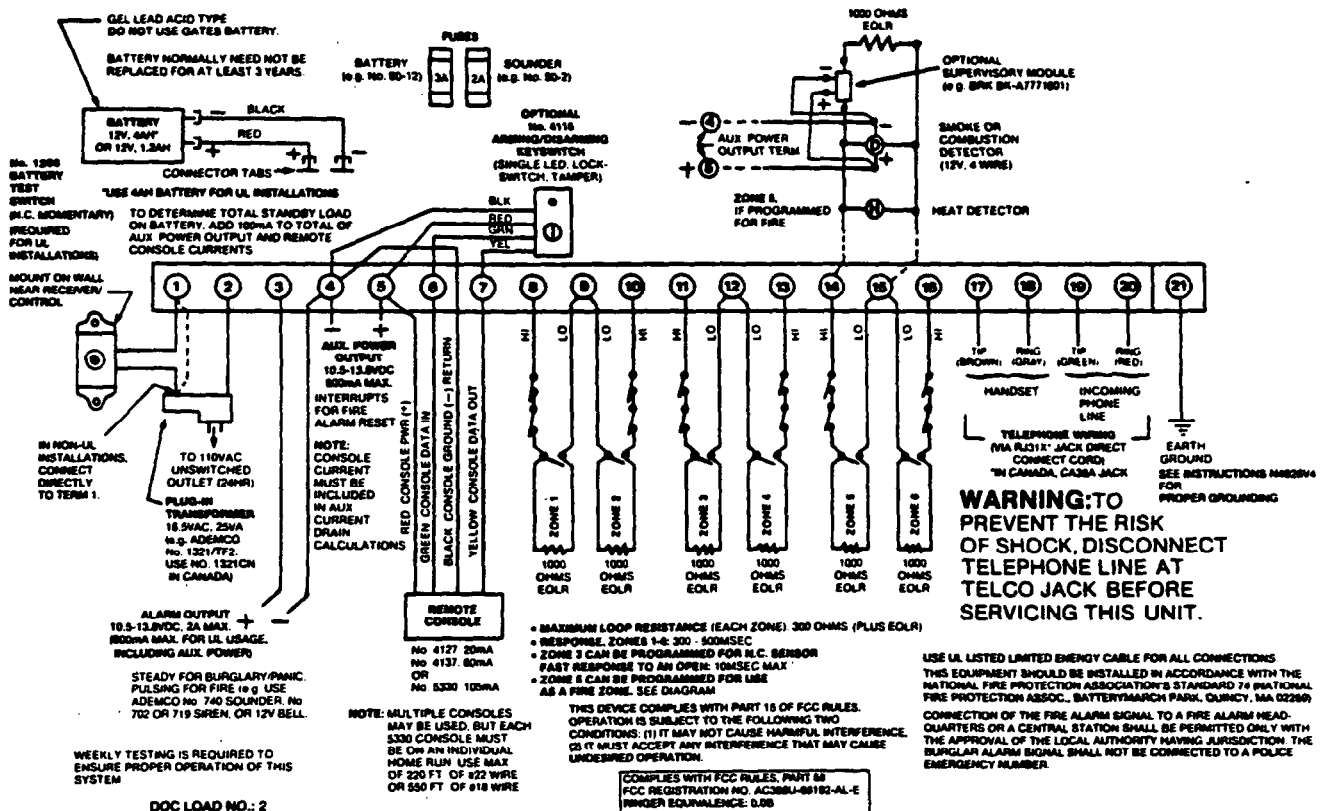

PROGRAMMING THE SECURITY CONTROL

Installer options are stored in non-removable, electrically erasable, non-volatile EEROM memory.* These options must be programmed for the particular installation to establish its specific alarm and reporting features. The security control may be programmed from a remote console.

When programming, the field number will be displayed on the LCD display; also, each entry is displayed as it is keyed in. After programming, values that have been entered in each field can be reviewed and, if necessary, modified.

*Note: It is possible to program the system at any time - even at the installer's premises prior to the actual installation. Simply apply power temporarily to the control and then program the unit as desired.

When programming from the console, note the following:

1. Enter the Programming mode by simultaneously depressing the [*] and [#] keys within 50 seconds after power is applied to the Control, or subsequently by keying the code 4 + 1 + 1 + 0 followed by depression of CODE + 0 keys. Once a Master code is programmed, use it instead of 4110 to gain access to the Programming mode.
2. Immediately following entry into the program mode, 20 will be displayed. (If a 5330 console is used, 00 will be displayed. Enter *20 to access the programming start point). Following the above display, the system is ready to accept entries for Address 20.
To program a data field, key [*] plus Address (for example, *21), then make the required entry. To simply review a data field, key [#] plus Address.
3. When a data field has been completely programmed, the console will normally "beep" three times and then automatically proceed to, and display, the next data field address to be programmed (if not, key [*] plus the address of the next field to be programmed).
4. If the number of digits that you enter in the data field is less than the maximum permitted (for example, phone number), then the console will display the last data entered. To proceed, the next data field address to be programmed must then be entered (for example, *42).
5. If an address is improperly entered, the console will display EE. Simply re-enter * or # plus the number.

The following is a description of commands necessary for programming:

FUNCTION	PROCEDURE
ENTER PROGRAMMING MODE:	<ol style="list-style-type: none"> 1. POWER UP, then depress [*] and [#] simultaneously within 50 seconds of powering up. OR 2. Initially, Key: 4 + 1 + 1 + 0 plus CODE key + 0. OR 3. After Master Code is programmed, key: Master Code + CODE key + 0. (If *98 was used to exit previously, method 1 above must be used to enter the program mode again.)
EXIT PROGRAMMING MODE	<ol style="list-style-type: none"> *99 (allows re-entry to programming mode via Type 3 entry method above) *98 (inhibits re-entry to programming mode via Type 3 entry method)
ADVANCE TO FIELD:	[*] + ADDRESS (e.g. 21, 35, 52, etc.).
PROGRAM FIELD:	[*] + ADDRESS, followed by data entries.
ERASE FIELDS:	[*] + ADDRESS + [*] (only applies to Addresses 40 thru 43 and 94.)
READ FIELD:	[#] + ADDRESS
SPECIAL MESSAGES.	
OC =	OPEN CIRCUIT (no communication between the Console and the Control).
EE =	ERROR (program entry mistake, re-enter the data).
After powering up, AC, dI (disabled) and NOT READY will be displayed after approximately 4 seconds. This will revert to READY in appx. 1 minute, which allows PIRS, etc. to stabilize. To bypass this delay, press: # + 0.	

SPECIFIC ADDRESS PROGRAMMING INSTRUCTIONS

Note: The following shows Factory Default Settings within brackets: []

THE PROGRAMMING FORM PRINTED ON PAGE 10 CAN BE USED TO RECORD THE DATA FOR THIS INSTALLATION

SYSTEM ARMING (*20-*23)

- *20 **MASTER SECURITY CODE**
[4][1][1][0] Enter 4 digits, 0-9 (entry of all 4 is mandatory). Use of a "9" in the last position inhibits the Ambush feature.
- *21 **QUICK ARM ENABLE**
[0] Enter 1 for enabled or 0 for disabled
- *22 **KEYSWITCH ENABLE**
[0] Enter 1 for enabled or 0 for disabled
- *23 **FORCED BYPASS ENABLE**
[0] Enter 1 for enabled or 0 for disabled

ZONE RESPONSE PROGRAMMING *29-*39

- *30 **ALARM BELL TIMEOUT**
[1] External sounder will shut off after time allotted. Enter 1 digit.
No timeout = 0 8 minutes = 2
4 minutes = 1 12 minutes = 3

Use the following table of zone types for programming addresses *31-*37

- 0= Zone Disabled
- 1= ENTRY/EXIT, Burglary
- 2= FIRE (w/ timeout)
- 3= PERIMETER, Burglary
- 4= INTERIOR, FOLLOWER, Burglary
- 5= TROUBLE BY DAY/ALARM BY NIGHT, Burglary
- 6= 24 Hr (Silent)
- 7= 24 Hr (Audible)
- 8= 24 Hr (Aux)
- 9= FIRE (w/o timeout), Fields *35 & *37 only

- *31 **RESPONSE TYPE FOR ZONE 1**
[1] Enter 1 digit
- *32 **RESPONSE TYPE FOR ZONE 2**
[4] Enter 1 digit
- *33 **RESPONSE TYPE FOR ZONE 3**
[3] Enter 1 digit
- *34 **RESPONSE TYPE FOR ZONE 4**
[3] Enter 1 digit
- *35 **RESPONSE TYPE FOR ZONE 5**
[2] Enter 1 digit,
- *36 **RESPONSE TYPE FOR ZONE 6**
[7] Enter 1 digit
- *37 **RESPONSE TYPE FOR ZONE 7 (Console Panic)**
[6] Enter 1 digit
Only zone types 0,2,6,7,8,9 applicable.
- *38 **ENTRY/EXIT DELAY**
[2] System will wait the time allotted before sounding alarm upon entering. Enter 1 digit.
Exit delay = Entry delay plus 15 seconds
0 = 0 Seconds 2 = 30 Seconds
1 = 20 Seconds 3 = 45 Seconds
- *39 **ZONE 3 RESPONSE TIME TO OPEN**
[0] 400 ms nominal = 0
10 ms nominal = 1

DIALER PROGRAMMING (*40-*48)

- *40 **PABX ACCESS CODE**
[][][][] Enter 4 digits, 0-9, for each PABX digit needed to access an outside line. To skip this field, enter *. If * is entered, no PABX number will be dialed and nothing will appear in this field. End field by entering *41 if not filled. To clear entries from field, press *40*.
- *41 **PRIMARY PHONE No.**
[][][][][][][][][][][][]
Enter up to 12 digits, 0-9. Do not fill unused spaces. End field by entering *42 if not filled. To clear entries from field, press *41*.

Note: Back-up reporting (8 calls are made to the secondary phone number if no acknowledgment is received after 8 attempts to the primary number) is automatic only if there is a secondary phone number.
- *42 **SECONDARY PHONE No.**
[][][][][][][][][][][][]
See above. End field by entering *43 if not filled. To clear entries from field, press *42*.
- *43 **SUBSCRIBER ACCT. No.**
[15][15][15][15]
Enter digits 0-9; #+11=B; #+12=C; #+13=D; #+14=E; or #+15=F. Enter * as the fourth digit if a 3 digit acct no. (for 3+1 dialer reporting format) is used. Enter 0 as the first digit of a 4-digit acct no. for nos. 0000-0999. End field by entering *44 if only 3 digits are used. To clear entries from field, press *43*.
- *44 **REPORT FORMAT**
[0] Determine which format is to be used to report to central station. Enter 1 digit.
0 = 3+1; 4+1 ADEMCO L/S Standard
1 = 3+1; 4+1 Radionics Standard
2 = 4+2 ADEMCO Lo Speed Standard
3 = 4+2 Radionics Standard
6 = 4+2 ADEMCO Express
8 = 3+1; 4+1 ADEMCO Lo Speed Expanded
9 = 3+1; 4+1 Radionics Expanded
(Enter * as the 4th digit of *43 if 3+1 dialer reporting is to be used.)
- *45 **PHONE SYSTEM SELECT [0]**
Enter 1 digit.
If Central Station Rcvr is *not* on WATS line:
0 = Pulse Dial 1 = Tone Dial
If Central Station Rcvr is on WATS line:
2 = Pulse Dial 3 = Tone Dial
- *46 **FUTURE USE [0]**
Enter 0.
- *47 **15 SECOND DELAY FOR BURG [0]**
0 = NO 1 = YES

FIELD FUNCTION PROGRAMMED VALUES

SYSTEM ARMING (*20-*23)

- *20 MASTER SECURITY CODE Enter 4 digits, 0-9
- *21 QUICK ARM ENABLE † 0 = no, 1 = yes
- *22 KEYSWITCH ENABLE † 0 = no, 1 = yes
- *23 FORCED BYPASS ENABLE † 0 = no, 1 = yes

ZONE RESPONSE PROGRAMMING (*29-*39)

- *30 ALARM BELL TIMEOUT †† 0 = none; 1 = 4 min; 2 = 8 min; 3 = 12 min
- *31 ZONE 1 RESPONSE TYPE
- *32 ZONE 2 RESPONSE TYPE
- *33 ZONE 3 RESPONSE TYPE
- *34 ZONE 4 RESPONSE TYPE
- *35 ZONE 5 RESPONSE TYPE
- *36 ZONE 6 RESPONSE TYPE
- *37 ZONE 7 RESPONSE TYPE CONSOLE PANIC. Only zone types 0, 2, 6, 7, 8, 9 applicable.
- *38 ENTRY DELAY †† 0 = 0 sec ; 1 = 20 sec; 2 = 30 sec; 3 = 45 sec
EXIT Delay = ENTRY Delay + 15 sec
- *39 ZONE 3 RESPONSE TO OPEN † 0 = 400 ms nominal; 1 = 10 ms nominal

ZONE TYPES FOR PROGRAMMING FIELDS *31-37

0 (or undefined) = Zone Disabled
 1 = ENTRY/EXIT, Burglary
 2 = FIRE with timeout
 3 = PERIMETER, Burglary
 4 = INTERIOR/FOLLOWER, Burglary
 5 = TROUBLE BY DAY/ALARM BY NIGHT, Burglary
 6 = 24 Hr (Silent)
 7 = 24 Hr (Audible)
 8 = 24 Hr (Auxiliary)
 9 = FIRE without timeout (Fields *35 and *37 only)

DIALER PROGRAMMING (*40-*47)

- *40 PABX ACCESS CODE Enter 4 digits, 0-9. If fewer than 4 digits entered, exit by pressing * (and press 41, if entering next field). To clear entries from field, press *40*.
- *41 PRIMARY PHONE No. Enter up to 12 digits, 0-9. Do not fill unused spaces. If fewer than 12 digits entered, exit by pressing * (and press 42, if entering next field). To clear entries from field, press *41*.
- *42 SECONDARY PHONE No. Enter up to 12 digits, 0-9. Do not fill unused spaces. If fewer than 12 digits entered, exit by pressing * (and press 43, if entering next field). To clear entries from field, press *42*.
- *43 SUBSCRIBER ACCOUNT No. Enter 0-9; #+11 for B; #+12 for C; #+13 for D; #+14 for E; #+15 for F. If only 3 digits used, exit by pressing * (and press 44, if entering next field). To clear entries from field, press *43*.

Examples: For Acct No. 1234, enter: 1 2 3 4
 For Acct No. B234, enter: #+11 2 3 4
 For Acct No. 123, enter: 1 2 3 *

- *44 REPORT FORMAT Enter * as the 4th digit of *43 if 3+1 dialer reporting is to be used.
 0 = 3+1, 4+1 ADEMCO L/S STANDARD 6 or undefined = 4+2 ADEMCO EXPRESS
 1 = 3+1, 4+1 RADIONICS STANDARD 8 = 3+1, 4+1 ADEMCO L/S EXPANDED
 2 = 4+2 ADEMCO L/S STANDARD 9 = 3+1, 4+1 RADIONICS EXPANDED
 3 = 4+2 RADIONICS STANDARD
- *45 PHONE SYSTEM SELECT †† If Cent. Sta. IS NOT on a WATS line: 0 = Pulse Dial; 1 = Tone Dial
 If Cent. Sta. IS on a WATS line: 2 = Pulse Dial; 3 = Tone Dial
- *46 FUTURE USE † Enter 0.
- *47 15 SEC DIALER DELAY (BURG) † 0 = no, 1 = yes

† If a number other than 0 or 1 is entered, even numbers = same as 0; odd numbers = same as 1.

†† If a number greater than 3 is entered, the control will subtract multiples of 4 to get to the allowable program range.

TO PROGRAM ALARM, SYSTEM STATUS, AND RESTORE REPORT CODES (*51-*74):

With a 3+1 or 4+1 Standard Format: Enter a code in the first box: 1-9, 0, B, C, D, E, or F. Enter [#+10] for 0, [#+11] for B, [#+12] for C, [#+13] for D, [#+14] for E, [#+15] for F.
 A [0] (not [#+10]) in the first box will disable a report.
 A [0] (not [#+10]) in the second box will result in automatic advance to the next field when programming.
 With an Expanded or 4+2 Format: Enter codes in both boxes (1st and 2nd digits) for 1-9, 0, or B-F, as described above.
 A [0] (not [#+10]) in the second box will eliminate the expanded message for that report.
 A [0] (not [#+10]) in both boxes will disable the report.

Examples: For Code 3 (Single Digit), enter:
 For Code 32 (Two Digits), enter:
 For Code B2 (Hexadecimal) enter:

ALARM REPORT CODES (*51-*59)

- *51 ZONE 1 ALARM REPORT CODE
- *52 ZONE 2 ALARM REPORT CODE
- *53 ZONE 3 ALARM REPORT CODE
- *54 ZONE 4 ALARM REPORT CODE
- *55 ZONE 5 ALARM REPORT CODE
- *56 ZONE 6 ALARM REPORT CODE
- *57 ZONE 7 ALARM REPORT CODE
(Console Panic)
- *58 ZONE 8 ALARM REPORT CODE
(Duress)
- *59 ZONE 9 ALARM REPORT CODE
(Tamper)

SYS STATUS RPT CODES (*60-*66)

- *60 TROUBLE REPORT CODE
- *61 BYPASS REPORT CODE
- *62 AC LOSS REPORT CODE
- *63 LOW BAT REPORT CODE
- *64 TEST REPORT CODE
- *65 OPEN REPORT CODE †††
- *66 CLOSE REPORT CODE †††

††† 2nd digit is automatically sent as the user number if expanded or 4+2 reporting is selected.

RESTORE RPT CODES (*70-*74)

- *70 ALARM RESTORE RPT CODE
2nd digit is automatically sent as the 2nd digit of the zone alarm report code programmed in *51-*59, if expanded or 4+2 reporting is selected.
- *71 TROUBLE RESTORE RPT CODE
- *72 BYPASS RESTORE RPT CODE
- *73 AC RESTORE RPT CODE
- *74 LOW BAT RESTORE RPT CODE

DOWNLOAD INFO (*94-*97)

- *94 DOWNLOAD PHONE No.

Enter up to 12 digits, 0-9. Do not fill unused spaces. If fewer than 12 digits entered, exit field by pressing * (and press 95, if entering next field). To clear entries from field, press *94*.
- *96 INITIALIZES DOWNLOAD ID, SUBSCRIBER ACCOUNT No. FOR INITIAL DOWNLOAD
No entry required.
- *97 ZEROS ALL PROGRAM FIELDS
No entry required.

TO EXIT PROGRAM MODE (*98 or *99)

- Press *98 or *99 if exiting programming, or next field number if continuing.
- *98 EXITS PROGRAMMING MODE and prevents re-entry by: Master Code + Code + 0.
- *99 EXITS PROGRAMMING MODE and allows re-entry by: Master Code + Code + 0.

FIELD FUNCTION PROGRAMMED VALUES

SYSTEM ARMING (*20-*23)

- *20 MASTER SECURITY CODE Enter 4 digits, 0-9
- *21 QUICK ARM ENABLE † 0 = no, 1 = yes
- *22 KEYSWITCH ENABLE † 0 = no, 1 = yes
- *23 FORCED BYPASS ENABLE † 0 = no, 1 = yes

ZONE RESPONSE PROGRAMMING (*29-*39)

- *30 ALARM BELL TIMEOUT †† 0 = none; 1 = 4 min; 2 = 8 min; 3 = 12 min
- *31 ZONE 1 RESPONSE TYPE
- *32 ZONE 2 RESPONSE TYPE
- *33 ZONE 3 RESPONSE TYPE
- *34 ZONE 4 RESPONSE TYPE
- *35 ZONE 5 RESPONSE TYPE
- *36 ZONE 6 RESPONSE TYPE
- *37 ZONE 7 RESPONSE TYPE CONSOLE PANIC. Only zone types 0, 2, 6, 7, 8, 9 applicable.
- *38 ENTRY DELAY †† 0 = 0 sec; 1 = 20 sec; 2 = 30 sec; 3 = 45 sec
EXIT Delay = ENTRY Delay + 15 sec
- *39 ZONE 3 RESPONSE TO OPEN † 0 = 400 ms nominal; 1 = 10 ms nominal

ZONE TYPES FOR PROGRAMMING FIELDS *31-37

0 (or undefined) = Zone Disabled
 1 = ENTRY/EXIT, Burglary
 2 = FIRE with timeout
 3 = PERIMETER, Burglary
 4 = INTERIOR/FOLLOWER, Burglary
 5 = TROUBLE BY DAY/ALARM BY NIGHT, Burglary
 6 = 24 Hr (Silent)
 7 = 24 Hr (Audible)
 8 = 24 Hr (Auxiliary)
 9 = FIRE without timeout (Fields *35 and *37 only)

DIALER PROGRAMMING (*40-*47)

- *40 PABX ACCESS CODE Enter 4 digits, 0-9. If fewer than 4 digits entered, exit by pressing * (and press 41, if entering next field). To clear entries from field, press *40*.
- *41 PRIMARY PHONE No. Enter up to 12 digits, 0-9. Do not fill unused spaces. If fewer than 12 digits entered, exit by pressing * (and press 42, if entering next field). To clear entries from field, press *41*.
- *42 SECONDARY PHONE No. Enter up to 12 digits, 0-9. Do not fill unused spaces. If fewer than 12 digits entered, exit by pressing * (and press 43, if entering next field). To clear entries from field, press *42*.
- *43 SUBSCRIBER ACCOUNT No. Enter 0-9; #+11 for B; #+12 for C; #+13 for D; #+14 for E; #+15 for F. If only 3 digits used, exit by pressing * (and press 44, if entering next field). To clear entries from field, press *43*.

Examples: For Acct No. 1234, enter: 1 2 3 4

For Acct No. B234, enter: #+11 2 3 4

For Acct No. 123, enter: 1 2 3 *

- *44 REPORT FORMAT Enter * as the 4th digit of *43 if 3+1 dialer reporting is to be used.
 0 = 3+1, 4+1 ADEMCO L/S STANDARD 6 or undefined = 4+2 ADEMCO EXPRESS
 1 = 3+1, 4+1 RADIONICS STANDARD 8 = 3+1, 4+1 ADEMCO L/S EXPANDED
 2 = 4+2 ADEMCO L/S STANDARD 9 = 3+1, 4+1 RADIONICS EXPANDED
 3 = 4+2 RADIONICS STANDARD
- *45 PHONE SYSTEM SELECT †† If Cent. Sta. IS NOT on a WATS line: 0 = Pulse Dial; 1 = Tone Dial
If Cent. Sta. IS on a WATS line: 2 = Pulse Dial; 3 = Tone Dial
- *46 FUTURE USE † Enter 0.
- *47 15 SEC DIALER DELAY (BURG) † 0 = no, 1 = yes

† If a number other than 0 or 1 is entered, even numbers = same as 0; odd numbers = same as 1.

†† If a number greater than 3 is entered, the control will subtract multiples of 4 to get to the allowable program range.

TO PROGRAM ALARM, SYSTEM STATUS, AND RESTORE REPORT CODES (*51-*74):

With a 3+1 or 4+1 Standard Format: Enter a code in the first box: 1-9, 0, B, C, D, E, or F. Enter [#+10] for 0, [#+11] for B, [#+12] for C, [#+13] for D, [#+14] for E, [#+15] for F.

A [0] (not [#+10]) in the first box will disable a report.

A [0] (not [#+10]) in the second box will result in automatic advance to the next field when programming.

With an Expanded or 4+2 Format: Enter codes in both boxes (1st and 2nd digits) for 1-9, 0, or B-F, as described above.

A [0] (not [#+10]) in the second box will eliminate the expanded message for that report.

A [0] (not [#+10]) in both boxes will disable the report.

Examples: For Code 3 (Single Digit), enter:

For Code 32 (Two Digits), enter:

For Code B2 (Hexadecimal) enter:

ALARM REPORT CODES (*51-*59)

- *51 ZONE 1 ALARM REPORT CODE
- *52 ZONE 2 ALARM REPORT CODE
- *53 ZONE 3 ALARM REPORT CODE
- *54 ZONE 4 ALARM REPORT CODE
- *55 ZONE 5 ALARM REPORT CODE
- *56 ZONE 6 ALARM REPORT CODE
- *57 ZONE 7 ALARM REPORT CODE
(Console Panic)
- *58 ZONE 8 ALARM REPORT CODE
(Duress)
- *59 ZONE 9 ALARM REPORT CODE
(Tamper)

SYS STATUS RPT CODES (*60-*66)

- *60 TROUBLE REPORT CODE
- *61 BYPASS REPORT CODE
- *62 AC LOSS REPORT CODE
- *63 LOW BAT REPORT CODE
- *64 TEST REPORT CODE
- *65 OPEN REPORT CODE †††
- *66 CLOSE REPORT CODE †††

††† 2nd digit is automatically sent as the user number if expanded or 4+2 reporting is selected.

RESTORE RPT CODES (*70-*74)

- *70 ALARM RESTORE RPT CODE
2nd digit is automatically sent as the 2nd digit of the zone alarm report code programmed in *51-*59, if expanded or 4+2 reporting is selected.
- *71 TROUBLE RESTORE RPT CODE
- *72 BYPASS RESTORE RPT CODE
- *73 AC RESTORE RPT CODE
- *74 LOW BAT RESTORE RPT CODE

DOWNLOAD INFO (*94-*97)

- *94 DOWNLOAD PHONE No.

Enter up to 12 digits, 0-9. Do not fill unused spaces. If fewer than 12 digits entered, exit field by pressing * (and press 95, if entering next field). To clear entries from field, press *94*.
- *96 INITIALIZES DOWNLOAD ID, SUBSCRIBER ACCOUNT No. FOR INITIAL DOWNLOAD
No entry required.
- *97 ZEROS ALL PROGRAM FIELDS
No entry required.

TO EXIT PROGRAM MODE (*98 or *99)

Press *98 or *99 if exiting programming, or next field number if continuing.

- *98 EXITS PROGRAMMING MODE and prevents re-entry by: Master Code + Code + 0.
- *99 EXITS PROGRAMMING MODE and allows re-entry by: Master Code + Code + 0.

➔ Continued from Page 8

The Alarm, System Status and Restore Report Codes shown in fields *51-*74 in the following sections may be designated to report to the central station in any of the above formats.

The 3+1 and 4+1 Standard formats comprise a 3 (or 4) digit subscriber number and a single digit report code (e.g. Alarm, Trouble, Restore, Open, Close).

The 3+1 and 4+1 Expanded formats comprise a 3 (or 4) digit subscriber number, and a single digit report code, followed by a second line where the report code is repeated 3 (or 4) times and followed by another number (normally the zone number) or user ID related to that report.

The 4+2 formats comprise a 4 digit subscriber number and single digit report code, immediately followed by the zone number (normally) or user ID.

Report	3+1/4+1 Standard	3+1/4+1 Expanded	4+2 Expanded
Alarm	SSS(S) A	SSS(S) A AAA(A) Z	SSSS AZ
Trouble	SSS(S) T	SSS(S) T TTT(T) t	SSSS Tt
Bypass	SSS(S) B	SSS(S) B BBB(B) b	SSSS Bb
AC Loss	SSS(S) E	SSS(S) E EEE(E) A _C	SSSS EA _C
Low Batt	SSS(S) L	SSS(S) L LLL(L) L _B	SSSS LL _B
Open	SSS(S) O	SSS(S) O OOO(O) U	SSSS OU
Close	SSS(S) C	SSS(S) C CCC(C) U	SSSS CU
Test	SSS(S) G	SSS(S) G GGG(G) g	SSSS Gg
Restore Alarm	SSS(S) R	SSS(S) R RRR(R) Z	SSSS RZ
AC Restore	SSS(S) R _A	SSS(S) R _A R _A R _A R _A (R _A)A _C	SSSS R _A A _C
LoBat Res.	SSS(S) R _L	SSS(S) R _L RRR(R _L)L _B	SSSS R _L L _B
Trouble Res.	SSS(S) R _T	SSS(S) R _T R _T R _T R _T (R _T)z	SSSS R _T t
Bypass Res.	SSS(S) R _B	SSS(S) R _B R _B R _B R _B (R _B)b	SSSS R _B b

Where:

SSS or SSSS = Subscriber ID
 A = Alarm Code-1st digit
 Z = Typically Zone Number'-2nd digit
 Tt = Trouble Code (1st & 2nd digits)
 Bb = Bypass Code (1st & 2nd digits)
 EA_C = AC Loss Code (1st & 2nd digits)
 LL_B = Low Battery Code(1st & 2nd digits)
 O = Open Code-1st Digit
 C = Close Code-1st Digit
 U = User Number (1st & 2nd digits)
 Gg = Test Code (1st & 2nd digits)
 R = Restore Code (Alarm)1st & 2nd digits
 R_Tt = Restore Code (Trbl)1st & 2nd digits
 R_Bb = Restore Code (Byps)1st & 2nd digits
 R_AA_C = Restore Code (AC)1st & 2nd digits
 R_LL_B = Restore Code (Bat)1st & 2nd digits

Zone numbers for: [] & [#] = 7
 Duress = 8
 Tamper = 9

TO PROGRAM ALARM, SYSTEM STATUS, AND RESTORE REPORT CODES (Fields *51-*74):

With a 3+1 or 4+1 Standard Format: Enter a code in the first box: 1-9, 0, B, C, D, E, or F. Enter [#+10] for 0, [#+11] for B, [#+12] for C, [#+13] for D, [#+14] for E, [#+15] for F.

A [0] (not [#+10]) in the first box will disable a report.

A [0] (not [#+10]) in the second box will result in automatic advance to the next field when programming.

With an Expanded or 4+2 Format: Enter codes in both boxes (1st and 2nd digits) for 1-9, 0, or B-F, as described above.

A [0] (not [#+10]) in the second box will eliminate the expanded message for that report.

A [0] (not [#+10]) in both boxes will disable the report.

See examples on programming form.

ALARM REPORT CODES (Fields *51 - *59)

- *51 ZONE 1 ALARM CODE [0][0]
- *52 ZONE 2 ALARM CODE [0][0]
- *53 ZONE 3 ALARM CODE [0][0]
- *54 ZONE 4 ALARM CODE [0][0]
- *55 ZONE 5 ALARM CODE [0][0]
- *56 ZONE 6 ALARM CODE [0][0]
- *57 ZONE 7 ALARM CODE
CONSOLE PANIC [0][0]
- *58 ZONE 8 ALARM CODE
DURESS [0][0]
- *59 ZONE 9 ALARM CODE
TAMPER [0][0]

SYSTEM STATUS CODES (Fields *60 - *66)

- *60 TROUBLE CODE [0][0]
- *61 BYPASS CODE [0][0]
- *62 AC LOSS CODE [0][0]
- *63 LO BAT CODE [0][0]
- *64 TEST RPT CODE [0][0]
- *65 OPEN RPT CODE [0] (2nd digit = User #)
- *66 CLOSE RPT CODE [0] (2nd digit = User #)

RESTORE REPORT CODES (Fields *70 - *74)

- *70 ALARM RESTORE RPT CODE 1ST DIGIT [0] (2nd digit normally zone #) When set to 0, all restores are disabled. The 2nd digit of an alarm restore 2 digit report is the same as the 2nd digit of the alarm report being restored as found in fields *51- *59.
- *71 TROUBLE RESTORE CODE [0][0] If the 1st digit is set to 0, reporting is disabled. Trouble restore is reported only if all troubles in the system are restored.
- *72 BYPASS RESTORE CODE [0][0] If the 1st digit is set to 0, reporting is disabled.
- *73 AC RESTORE RPT CODE [0][0] If the 1st digit is set to 0, reporting is disabled.
- *74 LO BAT RESTORE CODE [0][0] If the 1st digit is set to 0, reporting is disabled.

DOWNLOAD INFORMATION (*94-*97)

- *94 DOWNLOAD PHONE NUMBER [][][][][][][][][][][][][][][][]
Enter up to 12 digits; 0-9. Do not fill unused spaces. End field by entering * if not filled. To clear entries from field, press *94*.
 - *96 INITIALIZES DOWNLOAD ID AND SUBSCRIBER ACCT. No. FOR DOWNLOADING (No entry required)
 - *97 ZEROES ALL PROGRAM FIELDS (No entry required)
- TO EXIT PROGRAM MODE (*98 or *99)**
 Press *98 or *99 if exiting programming, or next field number if continuing.
- *98 EXITS PROGRAMMING MODE and prevents re-entry by: Master Code + Code + 0.
 - *99 EXITS PROGRAMMING MODE and allows re-entry by: Master Code + Code + 0.

4110 PROGRAMMING FORM

FIELD FUNCTION PROGRAMMED VALUES

SYSTEM ARMING (*20-*23)

- *20 MASTER SECURITY CODE Enter 4 digits, 0-9
- *21 QUICK ARM ENABLE † 0 = no, 1 = yes
- *22 KEYSWITCH ENABLE † 0 = no, 1 = yes
- *23 FORCED BYPASS ENABLE † 0 = no, 1 = yes

ZONE RESPONSE PROGRAMMING (*29-*39)

- *30 ALARM BELL TIMEOUT †† 0 = none; 1 = 4 min; 2 = 8 min; 3 = 12 min
- *31 ZONE 1 RESPONSE TYPE
- *32 ZONE 2 RESPONSE TYPE
- *33 ZONE 3 RESPONSE TYPE
- *34 ZONE 4 RESPONSE TYPE
- *35 ZONE 5 RESPONSE TYPE
- *36 ZONE 6 RESPONSE TYPE
- *37 ZONE 7 RESPONSE TYPE CONSOLE PANIC. Only zone types 0, 2, 6, 7, 8, 9 applicable.
- *38 ENTRY DELAY †† 0 = 0 sec; 1 = 20 sec; 2 = 30 sec; 3 = 45 sec
EXIT Delay = ENTRY Delay + 15 sec
- *39 ZONE 3 RESPONSE TO OPEN † 0 = 400 ms nominal; 1 = 10 ms nominal

ZONE TYPES FOR PROGRAMMING FIELDS *31-37

0 (or undefined) = Zone Disabled
 1 = ENTRY/EXIT, Burglary
 2 = FIRE with timeout
 3 = PERIMETER, Burglary
 4 = INTERIOR/FOLLOWER, Burglary
 5 = TROUBLE BY DAY/ALARM BY NIGHT, Burglary
 6 = 24 Hr (Silent)
 7 = 24 Hr (Audible)
 8 = 24 Hr (Auxiliary)
 9 = FIRE without timeout (Fields *35 and *37 only)

DIALER PROGRAMMING (*40-*47)

- *40 PABX ACCESS CODE Enter 4 digits, 0-9. If fewer than 4 digits entered, exit by pressing * (and press 41, if entering next field). To clear entries from field, press *40°.
- *41 PRIMARY PHONE No. Enter up to 12 digits, 0-9. Do not fill unused spaces. If fewer than 12 digits entered, exit by pressing * (and press 42, if entering next field). To clear entries from field, press *41°.
- *42 SECONDARY PHONE No. Enter up to 12 digits, 0-9. Do not fill unused spaces. If fewer than 12 digits entered, exit by pressing * (and press 43, if entering next field). To clear entries from field, press *42°.
- *43 SUBSCRIBER ACCOUNT No. Enter 0-9; #+11 for B; #+12 for C; #+13 for D; #+14 for E; #+15 for F. If only 3 digits used, exit by pressing * (and press 44, if entering next field). To clear entries from field, press *43°.

Examples: For Acct No. 1234, enter: 1 2 3 4
 For Acct No. B234, enter: #+11 2 3 4
 For Acct No. 123, enter: 1 2 3 *

- *44 REPORT FORMAT Enter * as the 4th digit of *43 if 3+1 dialer reporting is to be used.
 0 = 3+1, 4+1 ADEMCO L/S STANDARD 6 or undefined = 4+2 ADEMCO EXPRESS
 1 = 3+1, 4+1 RADIONICS STANDARD 8 = 3+1, 4+1 ADEMCO L/S EXPANDED
 2 = 4+2 ADEMCO L/S STANDARD 9 = 3+1, 4+1 RADIONICS EXPANDED
 3 = 4+2 RADIONICS STANDARD
- *45 PHONE SYSTEM SELECT †† If Cent. Sta. IS NOT on a WATS line: 0 = Pulse Dial; 1 = Tone Dial
 †† If Cent. Sta. IS on a WATS line: 2 = Pulse Dial; 3 = Tone Dial
- *46 FUTURE USE † Enter 0.
- *47 15 SEC DIALER DELAY (BURG) † 0 = no, 1 = yes

† If a number other than 0 or 1 is entered, even numbers = same as 0; odd numbers = same as 1.
 †† If a number greater than 3 is entered, the control will subtract multiples of 4 to get to the allowable program range.

OVER →

TO PROGRAM ALARM, SYSTEM STATUS, AND RESTORE REPORT CODES (*51-*74):

With a 3+1 or 4+1 Standard Format: Enter a code in the *first* box: 1-9, 0, B, C, D, E, or F. Enter [#+10] for 0, [#+11] for B, [#+12] for C, [#+13] for D, [#+14] for E, [#+15] for F.

A [0] (not [#+10]) in the *first* box will disable a report.

A [0] (not [#+10]) in the *second* box will result in automatic advance to the next field when programming.

With an Expanded or 4+2 Format: Enter codes in *both* boxes (1st and 2nd digits) for 1-9, 0, or B-F, as described above.

A [0] (not [#+10]) in the *second* box will eliminate the expanded message for that report.

A [0] (not [#+10]) in *both* boxes will disable the report.

Examples: For Code 3 (Single Digit), enter:

For Code 32 (Two Digits), enter:

For Code B2 (Hexadecimal) enter:

ALARM REPORT CODES (*51-*59)

- *51 ZONE 1 ALARM REPORT CODE
- *52 ZONE 2 ALARM REPORT CODE
- *53 ZONE 3 ALARM REPORT CODE
- *54 ZONE 4 ALARM REPORT CODE
- *55 ZONE 5 ALARM REPORT CODE
- *56 ZONE 6 ALARM REPORT CODE
- *57 ZONE 7 ALARM REPORT CODE
(Console Panic)
- *58 ZONE 8 ALARM REPORT CODE
(Duress)
- *59 ZONE 9 ALARM REPORT CODE
(Tamper)

SYS STATUS RPT CODES (*60-*66)

- *60 TROUBLE REPORT CODE
- *61 BYPASS REPORT CODE
- *62 AC LOSS REPORT CODE
- *63 LOW BAT REPORT CODE
- *64 TEST REPORT CODE
- *65 OPEN REPORT CODE ††
- *66 CLOSE REPORT CODE ††

†† 2nd digit is automatically sent as the user number if expanded or 4+2 reporting is selected.

RESTORE RPT CODES (*70-*74)

- *70 ALARM RESTORE RPT CODE
2nd digit is automatically sent as the 2nd digit of the zone alarm report code programmed in *51-*59, if expanded or 4+2 reporting is selected.
- *71 TROUBLE RESTORE RPT CODE
- *72 BYPASS RESTORE RPT CODE
- *73 AC RESTORE RPT CODE
- *74 LOW BAT RESTORE RPT CODE

DOWNLOAD INFO (*94-*97)

- *94 DOWNLOAD PHONE No.

Enter up to 12 digits, 0-9. Do not fill unused spaces. If fewer than 12 digits entered, exit field by pressing * (and press 95, if entering next field). To clear entries from field, press *94*.
- *96 INITIALIZES DOWNLOAD ID, SUBSCRIBER ACCOUNT No. FOR INITIAL DOWNLOAD
No entry required.
- *97 ZEROS ALL PROGRAM FIELDS
No entry required.

TO EXIT PROGRAM MODE (*98 or *99)

Press *98 or *99 if exiting programming, or next field number if continuing.

- *98 EXITS PROGRAMMING MODE and prevents re-entry by: Master Code + Code + 0.
- *99 EXITS PROGRAMMING MODE and allows re-entry by: Master Code + Code + 0.

TESTING THE SYSTEM

After installation is completed, the Security System should be carefully tested.

1. With the System in the disarmed state, check that all zones are intact. If **NOT READY** is displayed, press the [*] key to display the faulted zone(s). Restore faulted zone(s) if necessary, so that **READY** is displayed. Fault and restore every sensor individually to assure that it is being monitored by the system.
2. Enter the security code and press the **TEST** key. The external sounder (if used) should sound for 1 second and then turn off each time a contact is faulted. A test report should be transmitted (if programmed) to the Central Station immediately. If the backup battery is discharged or missing, the external sounder will not turn on and a **LOW BATTERY** report will be transmitted instead of a **TEST** report. The keypad will beep once per minute to indicate that the system is in the Test Mode.
3. **Battery Test:** For UL Listed Household fire/burglary installations, a Battery Test Switch (Ademco No. 1206) must be installed next to the Control, so that the system's backup battery can be tested periodically (at least weekly). To test the battery, enter test mode as described in step 2 above and check that the **POWER LED** is on, indicating the presence of AC power in the system. Momentarily depress the Battery Test Switch. If the battery is operational, the **POWER LED** will go out, but the system will remain in the Test mode. If the battery is weak, or not present, the system will reset and the console will display "dl". To restore the system, and silence any beeping, enter the security code and press the **OFF** key.

Alarm messages will be sent to the central station during the following tests 4 & 5. Notify them that tests will be in progress.

4. Arm the system and fault one or more zones. After 15 seconds (if optional dialer delay is selected), silence alarm sounder(s) by entering the code and pressing **OFF**. Check Entry/Exit delay zones.
5. Check the keypad-initiated alarm by pressing the Panic key pairs - [*] and [#]. If the system has been programmed for audible emergency, the console will emit a steady alarm sound, and **ALARM** and **07** will be displayed. Silence the alarm by entering the security code and pressing **OFF**.

If the system has been programmed for silent emergency, there will be no audible alarms or displays, but a report will be sent to the central station.

6. Notify the central station that all tests are finished, and verify results with them.

Note: If the battery standby capacity is exceeded during an AC power failure, the 4110 will automatically shut itself off.

TO THE INSTALLER

Regular maintenance and inspection (at least annually) by the installer and frequent testing by the user are vital to continuous satisfactory operation of any alarm system.

The installer should assume the responsibility of developing and offering a regular maintenance program to the user as well as acquainting the user with the proper operation and limitations of the alarm system and its component parts. Recommendations must be included for a specific program of frequent testing (at least weekly) to insure the system's proper operation at all times.

ACCESSORIES

No. 1321/TF2	16.5VAC, 25VA Plug-In Transformer (U.S.A. installations).	No. 4116	Tampered Single LED Remote Station (Arming/Disarming Key-switch). <i>NOTE: Obtain Lock-switch separately (Ademco No. 2174-70, 4073-70, or 4005-70).</i>
No. 1321CN	16.5VAC, 25VA Plug-In Transformer (Canadian installations).	No. 1206	Battery Test Switch (N.C. Momentary) Required for UL Installations
BRK PA400B	Piezoelectric Alarm Sounder, 90dB output (mounts in single-gang box).	BRK 1412	4-wire Ionization Products of Combustion Detector
No. 702	Self-contained 20 watt Siren (indoor or outdoor).	BRK 2412	4-wire Photoelectric Smoke Detector
No. 740	Extremely loud Piezoelectric Alarm Sounder, 122dB output (indoor or outdoor).	BRK 2412TH	4-wire Photoelectric Smoke Detector w/135°F (57°C) Heat Detector
No. 4110PRV2	Programming Form (Pkg of 50)		

also: Nos. 4127, 4137, and 5330
(see SPECIFICATIONS on next page).

SPECIFICATIONS

4110 SECURITY CONTROL

1. Physical: 12-1/2" (318mm)W
14-1/2" (368mm) H
3" (76mm) D

2. Electrical:

VOLTAGE INPUT: 16.5VAC from plug-in 25VA transformer, Ademco No. 1321/TF2, (in U.S.A.).

Note: For Canadian installations, a No. 1321CN transformer must be used.

RECHARGEABLE BACK-UP BATTERY: 12VDC, 4AH (Gel type)

ALARM SOUNDER: 10.5-13.8V, 2.0Amp output can drive 12V BELLS or can drive one or two 702 (series connected) self-contained 20-watt sirens. Do not connect two 702s in parallel.

AUXILIARY POWER OUTPUT: 10.5-13.8VDC, 500mA max. Interrupts for smoke detector reset.

Note: For UL installations, Alarm Sounder plus Auxiliary Power currents should not exceed 600mA.

STANDBY TIME: 4 HRS with Auxiliary load of 500mA (using 4AH battery). To determine total standby battery load, add 100mA to total Aux. power output and remote console currents.

FUSES: Battery (3A) No. 90-12
Sounder (2A) No. 90-2

3. Communication:

FORMATS SUPPORTED:

Ademco Express, 10 characters/sec. DTMF (TouchTone) Data Tones, 1400/2300Hz ACK, 1400Hz KISSOFF

Ademco Low Speed, 10 pulses/sec, 1900Hz Data Tone, 1400Hz ACK/KISSOFF

Radionics/SESCO, 20 pulses/sec, 1800Hz Data Tone, 2300Hz ACK/KISSOFF

Can report 0-9, B-F

Line Seize: Double Pole

Ringer Equivalence: 0.0B

FCC Registration No.: AC 398U-68192-AL-E

4127 REMOTE CONSOLE

1. Physical: 5-5/8" (143mm)W
4-11/16" (119mm) H
7/8" (22mm) D

2. Electrical: Voltage Input: 12VDC
Current Drain: 20mA

3. Interface Wiring:

RED: 12VDC input (+) aux pwr
GREEN: Data Out to Control
YELLOW: Data In from Control
BLACK: Ground

4137 REMOTE CONSOLE

1. Physical: 8-2/5" (213mm)W
4-3/4" (121mm) H
1-1/10" (28 mm) D

2. Electrical: Voltage Input: 12VDC
Current Drain: 60mA

3. Interface Wiring:

RED: 12VDC input (+) aux pwr
BLUE: 18VDC input from optional No 1350 or 1360 Power Pack
GREEN: Data Out to Control
YELLOW: Data In from Control
BLACK: Ground and (-) connection from optional No. 1350 or 1360 Power Pack

5330 REMOTE ALPHA CONSOLE

(Select Vector Device)

1. Physical: 7-3/4" (197mm)W
4-7/16" (113mm) H
1-1/4" (32mm) D

2. Electrical: Voltage Input: 12VDC
Current Drain: 105mA

3. Interface Wiring:

RED: 12VDC input (+) aux pwr
GREEN: Data Out to Control
YELLOW: Data In from Control
BLACK: Ground

WARNING
THE LIMITATIONS OF THIS ALARM SYSTEM

While this System is an advanced design security system, it does not offer guaranteed protection against burglary, fire or other emergency. Any alarm system, whether commercial or residential, is subject to compromise or failure to warn for a variety of reasons. For example:

- Intrusion detectors (e.g., passive infrared detectors), smoke detectors, and many other sensing devices will not work without power. Battery-operated devices will not work without batteries, with dead batteries, or if the batteries are not put in properly. Devices powered solely by AC will not work if their AC power supply is cut off for any reason, however briefly.
- A user may not be able to reach a panic or emergency button quickly enough.
- While smoke detectors have played a key role in reducing residential fire deaths in the United States, they may not activate or provide early warning for a variety of reasons in as many as 35% of all fires, according to data published by the Federal Emergency Management Agency. Some of the reasons smoke detectors used in conjunction with this System may not work are as follows. Smoke detectors may have been improperly installed and positioned. Smoke detectors may not sense fires that start where smoke cannot reach the detectors, such as in chimneys, in walls, or roofs, or on the other side of closed doors. Smoke detectors also may not sense a fire on another level of a residence or building. A second floor detector, for example, may not sense a first floor or basement fire. Finally, smoke detectors have sensing limitations. No smoke detector can sense every kind of fire every time. In general, detectors may not always warn about fires caused by carelessness and safety hazards like smoking in bed, violent explosions, escaping gas, improper storage of flammable materials, overloaded electrical circuits, children playing with matches, or arson. Depending on the nature of the fire and/or location of the smoke detectors, the detector, even if it operates as anticipated, may not provide sufficient warning to allow all occupants to escape in time to prevent injury or death.
- Passive Infrared Motion Detectors can only detect intrusion within the designed ranges as diagrammed in their installation manual. Passive Infrared Detectors do not provide volumetric area protection. They do create multiple beams of protection, and intrusion can only be detected in unobstructed areas covered by those beams. They cannot detect motion or intrusion that takes place behind walls, ceilings, floors, closed doors, glass partitions, glass doors, or windows. Mechanical tampering, masking, painting or spraying of any material on the mirrors, windows or any part of the optical system can reduce their detection ability. Passive Infrared Detectors sense changes in temperature; however, as the ambient temperature of the protected area approaches the temperature range of 90° to 150°F, the detection performance can decrease.
- Alarm warning devices such as sirens, bells or horns may not alert people or wake up sleepers if they are located on the other side of closed or partly open doors. If warning devices are located on a different level of the residence from the bedrooms, then they are less likely to waken or alert people inside the bedrooms. Even persons who are awake may not hear the warning if the alarm is muffled by noise from a stereo, radio, air conditioner or other appliance, or by passing traffic. Finally, alarm warning devices, however loud, may not warn hearing-impaired people.
- Telephone lines needed to transmit alarm signals from a premises to a central monitoring station may be out of service or temporarily out of service. Telephone lines are also subject to compromise by sophisticated intruders.
- Even if the system responds to the emergency as intended, however, occupants may have insufficient time to protect themselves from the emergency situation. In the case of a monitored alarm system, authorities may not respond appropriately.
- This equipment, like other electrical devices, is subject to component failure. Even though this equipment is designed to last as long as 20 years, the electronic components could fail at any time.

The most common cause of an alarm system not functioning when an intrusion or fire occurs is inadequate maintenance. This alarm system should be tested weekly to make sure all sensors are working properly. The security console (and remote keypad) should be tested as well.

Installing an alarm system may make the owner eligible for a lower insurance rate, but an alarm system is not a substitute for insurance. Homeowners, property owners and renters should continue to act prudently in protecting themselves and continue to insure their lives and property.

We continue to develop new and improved protection devices. Users of alarm systems owe it to themselves and their loved ones to learn about these developments.

**CANADIAN DEPARTMENT OF COMMUNICATIONS
(DOC) STATEMENT**

NOTICE

The Canadian Department of Communications label identifies certified equipment. This certification means that the equipment meets certain telecommunications network protective, operational and safety requirements. The Department does not guarantee the equipment will operate to the user's satisfaction.

Before installing this equipment, users should ensure that it is permissible to be connected to the facilities of the local telecommunications company. The equipment must also be installed using an acceptable method of connection. In some cases, the company's inside wiring associated with a single line individual service may be extended by means of certified connector assembly (telephone extension cord). The customer should be aware that compliance with the above conditions may not prevent degradation of service in some situations.

Repairs to certified equipment should be made by an authorized Canadian maintenance facility designated by the supplier. Any repairs or alterations made by the user to this equipment, or equipment malfunctions, may give the telecommunications company cause to request the user to disconnect the equipment.

Users should ensure for their own protection that the electrical ground connections of the power utility, telephone lines and internal metallic water pipe system, if present, are connected together. This precaution may be particularly important in rural areas.

Caution: User should not attempt to make such connections themselves, but should contact the appropriate electric inspection authority, or electrician, as appropriate.

The Load Number (LN) assigned to each terminal device denotes the percentage of the total load to be connected to a telephone loop which is used by the device, to prevent overloading. The termination on a loop may consist of any combination of devices subject only to the requirement that the total of the Load Numbers of all the devices does not exceed 100.

AVIS

L'étiquette du ministère des Communications du Canada identifie le matériel homologué. Cette étiquette certifie que le matériel est conforme à certaines normes de protection, d'exploitation et de sécurité des réseaux de télécommunications. Le ministère n'assure toutefois pas que le matériel fonctionnera à la satisfaction de l'utilisateur.

Avant d'installer ce matériel, l'utilisateur doit s'assurer qu'il est permis de le raccorder aux installations de l'entreprise locale de télécommunication. Le matériel doit également être installé en suivant une méthode acceptée de raccordement. Dans certains cas, les fils intérieurs de l'entreprise utilisés pour un service individuel à ligne unique peuvent être prolongés au moyen d'un dispositif homologué de raccordement (cordon prolongateur téléphonique interne). L'abonné ne doit pas oublier qu'il est possible que la conformité aux conditions énoncées ci-dessus n'empêchent pas la dégradation du service par certaines situations. Actuellement, les entreprises de télécommunication ne permettent pas que l'on raccorde leur matériel aux jacks d'abonnés, sauf dans les cas précis prévus par les tarifs particuliers de ces entreprises.

Les réparations de matériel homologué doivent être effectuées par un centre d'entretien canadien autorisé désigné par le fournisseur. La compagnie de télécommunications peut demander à l'utilisateur de débrancher un appareil à la suite de réparations ou de modifications effectuées par l'utilisateur ou à cause de mauvais fonctionnement.

Pour sa propre protection, l'utilisateur doit s'assurer que tous les fils de mise à la terre de la source d'énergie électrique, des lignes téléphoniques et des canalisations d'eau métalliques, s'il y en a, sont raccordés ensemble. Cette précaution est particulièrement importante dans les régions rurales.

Avertissement: L'utilisateur ne doit pas tenter de faire ces raccordements lui-même; il doit avoir recours à un service d'inspection des installations électriques, ou à un électricien, selon le cas.

L'indice de charge (IC) assigné à chaque dispositif terminal pour éviter toute surcharge indique le pourcentage de la charge totale qui peut être raccordeé à un circuit téléphonique bouclé utilisé par ce dispositif. La terminaison du circuit bouclé peut être constituée de n'importe quelle combinaison de dispositifs, pourvu que la somme des indices de charge de l'ensemble des dispositifs ne dépasse pas 100.

FEDERAL COMMUNICATIONS COMMISSION (FCC) STATEMENT

This equipment has been tested to FCC requirements and has been found acceptable for use. The FCC requires the following statement for your information:

This equipment generates and uses radio frequency energy and if not installed and used properly, that is, in strict accordance with the manufacturer's instructions, may cause interference to radio and television reception. It has been type tested and found to comply with the limits for a Class B computing device in accordance with the specifications in Part 15 of FCC Rules, which are designed to provide reasonable protection against such interference in a residential installation. However, there is no guarantee that interference will not occur in a particular installation. If this equipment does cause interference to radio or television reception, which can be determined by turning the equipment off and on, the user is encouraged to try to correct the interference by one or more of the following measures:

- If using an indoor antenna, have a quality outdoor antenna installed.
- Reorient the receiving antenna until interference is reduced or eliminated.
- Move the radio or television receiver away from the receiver/control.
- Move the antenna leads away from any wire runs to the receiver/control.
- Plug the receiver/control into a different outlet so that it and the radio or television receiver are on different branch circuits.

If necessary, the user should consult the dealer or an experienced radio/television technician for additional suggestions. The user or installer may find the following booklet prepared by the Federal Communications Commission helpful:
"Interference Handbook"

This booklet is available under Stock No. 004-000-00450-7 from the U.S. Government Printing Office, Washington, DC 20402.

The user shall not make any changes or modifications to the equipment unless authorized by the Installation Instructions or User's Manual. Unauthorized changes or modifications could void the user's authority to operate the equipment.

ADEMCO LIMITED WARRANTY

Alarm Device Manufacturing Company, a Division of Pittway Corporation, and its divisions, subsidiaries and affiliates ("Seller"), 165 Eileen Way, Syosset, New York 11791, warrants its products to be in conformance with its own plans and specifications and to be free from defects in materials and workmanship under normal use and service for 18 months from the date stamp control on the product or, for products not having an Ademco date stamp, for 12 months from date of original purchase unless the installation instructions or catalog sets forth a shorter period, in which case the shorter period shall apply. Seller's obligation shall be limited to repairing or replacing, at its option, free of charge for materials or labor, any product which is proved not in compliance with Seller's specifications or proves defective in materials or workmanship under normal use and service. Seller shall have no obligation under this Limited Warranty or otherwise if the product is altered or improperly repaired or serviced by anyone other than Ademco factory service. For warranty service, return product transportation prepaid, to Ademco Factory Service, 165 Eileen Way, Syosset, New York 11791.

THERE ARE NO WARRANTIES, EXPRESS OR IMPLIED, OF MERCHANTABILITY, OR FITNESS FOR A PARTICULAR PURPOSE OR OTHERWISE, WHICH EXTEND BEYOND THE DESCRIPTION ON THE FACE HEREOF. IN NO CASE SHALL SELLER BE LIABLE TO ANYONE FOR ANY CONSEQUENTIAL OR INCIDENTAL DAMAGES FOR BREACH OF THIS OR ANY OTHER WARRANTY, EXPRESS OR IMPLIED, OR UPON ANY OTHER BASIS OF LIABILITY WHATSOEVER, EVEN IF THE LOSS OR DAMAGE IS CAUSED BY THE SELLER'S OWN NEGLIGENCE OR FAULT.

Seller does not represent that the products it sells may not be compromised or circumvented; that the products will prevent any personal injury or property loss by burglary, robbery, fire or otherwise; or that the products will in all cases provide adequate warning or protection. Customer understands that a properly installed and maintained alarm may only reduce the risk of a burglary, robbery, fire or other events occurring without providing an alarm, but it is not insurance or a guarantee that such will not occur or that there will be no personal injury or property loss as a result. CONSEQUENTLY, SELLER SHALL HAVE NO LIABILITY FOR ANY PERSONAL INJURY, PROPERTY DAMAGE OR OTHER LOSS BASED ON A CLAIM THE PRODUCT FAILED TO GIVE WARNING. HOWEVER, IF SELLER IS HELD LIABLE, WHETHER DIRECTLY OR INDIRECTLY, FOR ANY LOSS OR DAMAGE ARISING UNDER THIS LIMITED WARRANTY OR OTHERWISE, REGARDLESS OF CAUSE OR ORIGIN, SELLER'S MAXIMUM LIABILITY SHALL NOT IN ANY CASE EXCEED THE PURCHASE PRICE OF THE PRODUCT, WHICH SHALL BE THE COMPLETE AND EXCLUSIVE REMEDY AGAINST SELLER. This warranty replaces any previous warranties and is the only warranty made by Seller on this product. No increase or alteration, written or verbal, of the obligations of this Limited Warranty is authorized.

® ADEMCO

ALARM DEVICE MANUFACTURING CO.
A DIVISION OF PITTHWAY CORPORATION
165 Eileen Way, Syosset, New York 11791

Copyright © 1990 PITTHWAY CORPORATION