

Dear Tech-Man Subscriber:

ADEMCO apologizes for any misunderstanding that has arisen due to our recent decision to have our technical information removed from the Tech-Man web site. You may appreciate that one of our key concerns is to provide installing security dealers with timely and accurate information on our products, and we were concerned about the data posted to the Tech-Man web site. For obvious reasons, we also do not wish unauthorized individuals to have access to information on installing and configuring ADEMCO systems. These concerns were what prompted us to ask Tech-Man to stop posting ADEMCO installation instructions and user manuals.

Several of you have written us to ask that we reconsider this decision. We have. We will not require Tech-Man to remove the ADEMCO data. ADEMCO, however, is not responsible for the operation and maintenance of this site - thus we cannot guarantee the timeliness or accuracy of the information posted on the Tech-Man web site.

The ADEMCO web site is located at www.ademco.com and contains accurate timely data about our products. You may request a PIN number for access to the ADEMCO Technical Support web site and FAXBACK system.

If you need assistance on troubleshooting, or if you have other technical questions about our products not addressed in the information posted at our web site, please contact ADEMCO Technical Support at 800-645-7492.

Thank you for understanding.

Sincerely,

Herb Lustig

VISTA

4120XM

INSTALLATION INSTRUCTIONS



CONGRATULATIONS!

On Your Purchase of the Ademco 4120XM

The purpose of these Installation Instructions is to give you a complete overview of the system, and provide detailed instructions for installing a basic system.

CONTACTING TECHNICAL SUPPORT

PLEASE,

Before you call Technical Support, be sure you:

- **READ THE INSTRUCTIONS!**
- **Check all wiring connections.**
- **Determine that the power supply and/or backup battery are supplying proper voltages.**
- **Verify your programming information where applicable.**
- **Note the proper model number of this product, and the version level (if known) along with any documentation that came with the product.**
- **Note your ADEMCO customer number and/or company name.**

Having this information handy will make it easier for us to serve you quickly and effectively.

You may contact Technical Support via Toll-Free FAX. Please include your return FAX number. You will receive a reply within 24 hours. You may also contact Technical Support via modem to ATLIS-BBS, Technical Support's Electronic Bulletin Board System. Replies are posted within 24 hours.

East Coast Technical Support: 1-800-645-7492 (8 a.m.-6 p.m. E.S.T.)

West Coast Technical Support: 1-800-458-9469 (8 a.m.-5 p.m. P.S.T.)

Technical Support FAX Number: 1-800-447-5086

*ATLIS-BBS Electronic Bulletin Board System: 1-516-496-3980
(1200 - 9600 Baud, 8 Data Bits, 1 Start/Stop Bit, No Parity)*

ATLIS FAX – Automated Fax Retrieval System: 1-800-645-7568 / Ext. 1403

TABLE OF CONTENTS

Section 1.	GENERAL INFORMATION	7
	SUMMARY OF SYSTEM FEATURES	7
	System Features	8
Section 2.	ZONE CONFIGURATIONS	9
	ZONE TYPES & APPLICABLE SENSORS	9
	BASIC 8 HARD-WIRED ZONES	10
	Zone 1	10
	Compatible Smoke Detectors	11
	Zones 2 – 8	11
	Compatible Glassbreak Detectors	12
	Glassbreak Detector Connections	12
	Wired Zone Expansion	13
	4219 Zone Expander	13
	WIRELESS EXPANSION (Zones 1-63)	14
	General Information (Receivers)	14
	4281 Series Receivers	15
	5700 Series Transmitters	16
	Wireless Zone Types	17
	Advisories	18
	Fault Annunciation	18
	Important Battery Notice	18
	Compatible 5700 Series Wireless Devices	18
	VOLTAGE TRIGGER OUTPUTS (Connector TB2)	19
	General Information	19
	Remote Keyswitch Usage	20
	Remote Console Sounder	20
	Application	20
	Programming & Wiring	20
Section 3.	REMOTE CONSOLES, EXTERNAL SOUNDERS AND PHONE CONNECTIONS	22
	REMOTE CONSOLES	22
	General	22
	4127	22
	4137AD	22
	5137AD	22
	6137	22
	6139	23
	Mounting The Consoles	23
	Wiring Consoles	23
	Powering Additional Consoles	23
	EXTERNAL SOUNDERS	24
	Relay Output	24
	UL Installations	24
	Non-UL Installations	24
	Compatible Sounders	24
	PHONE CONNECTIONS	24
	Phone Line Connections	24
	Ground Start Module	25
Section 4.	MOUNTING THE CABINET, PC BOARD & LOCK	26
	MOUNTING THE CABINET	26
	MOUNTING THE PC BOARD	26
	MOUNTING THE CABINET LOCK	26

Section 5.	POWERING THE SYSTEM	27
	PRIMARY POWER	27
	BACK-UP POWER.....	27
	EARTH GROUND CONNECTIONS.....	27
	POWER-UP PROCEDURE.....	27
	WIRING INFORMATION FOR CONSOLES, RF RECEIVERS, AND OTHER DEVICES.....	28
Section 6.	SYSTEM OPERATION	29
	SECURITY ACCESS CODES.....	29
	General Information	29
	Choice of 4-Digit (Standard) or 6-Digit (High Security) Codes.....	29
	User Codes & Levels Of Authority	29
	Assigning or Deleting Temporary Codes By User 2.....	30
	Assigning or Deleting Temporary Codes By User 3.....	31
	CONSOLE KEYPAD FUNCTIONS	31
	General Information	31
	Arming Functions	32
	Panic Keys	32
	Viewing Downloaded Messages (Alpha Consoles Only)	32
	Using The Built-In User's Guide (Alpha Consoles Only).....	33
	Displaying Descriptors (Alpha Consoles Only)	33
	Recalling Alarm & Trouble Messages	33
	Trouble Conditions.....	33
	"Check" Messages.....	33
	Other Trouble Conditions.....	34
	Power Failure	34
Section 7.	SYSTEM COMMUNICATION	35
	SPLIT/DUAL REPORTING	35
	ADEMCO LOW SPEED	35
	SESCO/RADIONICS	35
	4+2 REPORTING	35
	4+2 EXPRESS	36
	ADEMCO HIGH SPEED REPORTING	36
	CONTACT ID REPORTING	37
	Table of Contact ID Event Codes	37
	4120XM Communication Programming Guide.....	38
Section 8.	PROGRAMMING THE SYSTEM	39
	General	39
	Default Programming	39
	Data Programming.....	39
	Programming Steps	40
	COMMUNICATION DEFAULT PROGRAMMING.....	41
	Easy To Program Communication Fields.....	41
	Low Speed	41
	Ademco Express	42
	Ademco High Speed	42
	Ademco Contact ID	42
	Communication Defaults For Low Speed Format	43
	Communication Defaults For Ademco Express Format	44
	Communication Defaults For Ademco High Speed Format	45
	Communication Defaults For Ademco's Contact Id Format.....	46
	DESCRIPTION OF 4120XM PROGRAMMING FIELDS.....	47

	PROGRAMMING ZONE DESCRIPTIONS (Alpha Consoles).....	57
	General	57
	Entering Zone Descriptions.....	57
	Adding Custom Words	58
	Creating a Custom Message Display (Installer's Message).....	58
	Standard Vocabulary of Words Stored in Memory.....	59
Section 9.	DOWNLOADING PRIMER	60
	What is Downloading?	60
	How Does Downloading Work?	60
	What Can Be Done Once Panel is On-Line?	61
	How Secure is Downloading?	61
	DIRECT WIRE DOWNLOADING	62
	Direct Wire Connections	62
Section 10.	TESTING THE SYSTEM	63
	USING THE TEST MODE.....	63
	ARMED SYSTEM TEST	63
	TURNING THE SYSTEM OVER TO THE USER	64
Section 11.	TROUBLESHOOTING	65
	REMOTE CONSOLES.....	65
	HARD-WIRED ZONES 1-8.....	65
	HARD-WIRED ZONES ON 4219 WIRED ZONE EXPANDER	65
	WIRELESS.....	66
	COMMUNICATIONS.....	67
	IN THE EVENT OF TELEPHONE OPERATIONAL PROBLEMS	67
Section 12.	SPECIFICATIONS	68
	4120XM Control	68
	4127 Console	68
	4137AD/5137AD Console	68
	6127 Console	69
	6137 Console	69
	6139 Console	69
	DIP SWITCH TABLES FOR WIRELESS DEVICES	71
	FCC STATEMENTS	72
	DOC STATEMENT.....	73
	LIMITATIONS STATEMENT	74
	ADEMCO LIMITED WARRANTY.....	75
	TABLE 1. AUXILIARY DEVICE CURRENT DRAW WORKSHEET	28
	TABLE 2. WIRING RUN CHART FOR DEVICES DRAWING POWER FROM THE CONTROL (Terminals 5 & 8)	28

LIST OF ILLUSTRATIONS

Figure 1.	4219 ZONE EXPANDER	13
Figure 2.	4281 TYPE RF RECEIVER	15
Figure 3.	REMOTE KEYSWITCH WIRING	21
Figure 4.	PHONE CONNECTIONS.....	25
Figure 5.	GROUND START MODULE CONNECTIONS	25
Figure 6.	MOUNTING THE PC BOARD	26
Figure 7.	MOUNTING THE CABINET LOCK.....	26
Figure 8.	DIRECT WIRE DOWNLOADING CONNECTIONS	62
Figure 9.	SUMMARY OF CONNECTIONS DIAGRAM	70

Section 1. GENERAL INFORMATION

SUMMARY OF SYSTEM FEATURES

System Features

The Following Table Lists The Major Features Of The System.

NOTE:
Addressable consoles (5137AD, 6137, and 6139) MUST be set to the non-addressable mode (address 31) when used in this system

System	The 4120XM Control is a microprocessor based, programmable system, and features EEROM memory technology (power loss does not result in the loss of information).
Zones Supported	<ul style="list-style-type: none"> • Supports up to 8 traditional wired zones of protection standard. • The standard 8 basic wired zones of protection may be expanded by an additional 8 wired zones using an Ademco 4219 zone expander. • Wireless expansion can also be used to provide an additional 4 wireless zones with a 4281L RF receiver, or an additional 8 wireless zones using a 4281M or H RF receiver. • A total number of 24 zones is therefore possible in this system, using a combination of wired and wireless zone expansion.
Fire Zones	<ul style="list-style-type: none"> • Supports up to eight 2-wire smoke detectors on zone 1. • Other zones can be fire zones using 4-wire smoke and heat detectors.
Remote Consoles	• Supports up to six remote consoles (4127, 6127, 4137AD, 5137AD, 6137 or 6139. <i>Addressable consoles must be set to the non-addressable mode (ID 31).</i>
Keyswitch	Supports the Ademco 4146 keyswitch.
Programming	<ul style="list-style-type: none"> • Programming can be performed at the office prior to installation, or on the job site directly from the console. • Can be downloaded from a remote location* or at the job site (using a PC/laptop with 4100SM Serial Module) by using the Ademco 4130PC Downloading Software. • The Control is pre-programmed with a set of standard values that is designed to meet the needs of many installations. These values, however, can be changed to suit the needs of any particular installation. • The Control can also be pre-programmed by the installer with one of four standard communication default programming values, thus further saving time and effort.
User Codes	Supports up to 70 user codes.
Panic Keys	Provides 3 panic key functions.
Communication	Ademco Low Speed, SESCOA/RADIONICS, Ademco Express, Ademco High Speed, Ademco Contact ID
Security Code	• Choice of normal (4-digit) or high security (6-digit) security codes.
Descriptors	<ul style="list-style-type: none"> • All zones can be assigned alpha descriptions. • Up to 20 custom words can be added to the built-in vocabulary. The letter "s" or " 's " can also be added to descriptors.

* UL NOTE: Downloading is not permissible for UL installations.

(Continued over)

Major Features Of The System (Continued)

Communication Fields	<ul style="list-style-type: none"> Easier programming for communication fields. Simply enter the desired code for each zone.
Communication Defaults	<ul style="list-style-type: none"> Communication default programming can be loaded anytime, and does not affect non-communication program fields.
Reporting Formats	<ul style="list-style-type: none"> All zones can report to a central station using any reporting format.
Callback	<ul style="list-style-type: none"> Callback defeat option for downloading.
AC Loss Reporting	<ul style="list-style-type: none"> Random AC Loss reporting option sends report randomly from 10-40 minutes after AC loss, to help prevent central stations from receiving an overload of reports due to area blackouts.
Test Reporting	<ul style="list-style-type: none"> Intelligent test reporting option means test reports will not be sent if any other report was sent within the programmed test report interval.
Quick Bypass	<ul style="list-style-type: none"> Quick (forced) bypass feature bypasses all faulted zones with single key entry sequence (Code + BYPASS + #).
Installer Code	<ul style="list-style-type: none"> Installer code override feature. Installer code will disarm system only if it was used to arm the system.
Circuit Breakers	<ul style="list-style-type: none"> Self-resetting circuit breaker protection eliminates the need to replace blown cartridge fuses.
Cabinet	<ul style="list-style-type: none"> Larger cabinet with removable door.
Downloading*	<ul style="list-style-type: none"> Direct wire downloading can be done without a modem, using a PC computer and 4100SM Serial Module.
Split/Dual Reporting	<ul style="list-style-type: none"> Split/Dual reporting communicator option has been added.
Cancel Report	<ul style="list-style-type: none"> Option to allow a cancel report to be sent, even after Bell Time-out has ended.
Voltage Triggers	<ul style="list-style-type: none"> Used to interface with LORRA or other devices. PC Downloader ability to individually command output voltage triggers to pulse on for 2 seconds.

* UL NOTE: Downloading is not permissible for UL installations.

Section 2. ZONE CONFIGURATIONS

ZONE TYPES & APPLICABLE SENSORS

The system supports up to 24 zones of hard-wire and/or wireless protection. The following table lists the zone numbers and the types of sensors that can be used with each in this system:

Zone	Sensors
1	2-wire smoke detectors (if used)
7	Keyswitch (if used)
6	Latching type glass break detectors (if used)
1-8	Traditional hard-wired zones
1-24	5700 series wireless devices
95	Panic keys */1 (or key A on some consoles)
96	Panic keys */3 (or key C on some consoles)
99	Panic keys */# (or key B on some consoles)

Each zone must be assigned to a zone type, which defines the way in which the system responds to faults in that zone. In addition, there are three keypad activated zones (PANIC keys) and two RF supervisory zones, one for each 4281 RF Receiver installed, and two for a 4219 zone expander (if used). Zone types are defined below.

Type 00 Program a zone with this zone type if the zone is not used.

Type 01
Entry/Exit #1 Burglary. This zone type provides entry delay whenever the zone is faulted if the control is armed in the Away or Stay modes. When the panel is armed in the Instant or Maximum modes, no entry delay is provided. Exit delay begins whenever the control is armed, regardless of the arming mode selected. These delays are programmable. This zone type is usually assigned to sensors or contacts on doors through which primary entry and exit will take place.

Type 02
Entry/Exit #2 Burglary. This zone type provides a secondary entry delay whenever the zone is faulted if the panel is armed in the Away and Stay modes. When the panel is armed in the Instant or Maximum modes, no entry delay is provided. Secondary exit delay begins whenever the control is armed, regardless of the arming mode selected. These delays are programmable. This zone type is usually assigned to sensors or contacts on doors through which secondary entry and exit will take place, and where more time might be needed to get to and from the console. Delay time must be greater than Zone type 1. (Ex.: a garage, loading dock, or basement door)

Type 03
Perimeter Burglary. This zone type gives an instant alarm if the zone is faulted when the panel is armed in the Away, Stay, Instant or Maximum modes. This zone type is usually assigned to all sensors or contacts on exterior doors and windows.

Type 04
Interior, Follower. This zone type gives a delayed alarm (using the programmed Entry/exit time) if the Entry/Exit zone is faulted first. Otherwise this zone type gives an instant alarm. This zone type is active when the panel is armed in the Away or maximum modes. Maximum mode eliminates the delay though. **This zone type is bypassed automatically when the panel is armed in the Stay or Instant modes.** This zone type is usually assigned to a zone covering an area such as a foyer, lobby, or hallway through which one must pass upon entry (After faulting the entry/exit zone to reach the console to disarm the system.) Since this zone type is designed to provide an instant alarm if the entry/exit zone is not violated first, it will protect an area in the event an intruder hides on the premises prior to the system being armed, or gains access to the premises through an unprotected area.

Type 05
Trouble by Day/Alarm by Night. This zone type will give an instant alarm if faulted when armed in the Away, Stay, Instant or Maximum (night) modes. During the disarmed state (day), the system will provide a latched trouble sounding from the console (and a central station report, if desired). This zone type is usually assigned to a zone which contains a foil-protected door or window (such as in a store), or to a zone covering a "sensitive" area such as a stock room, drug supply room, etc. This zone type can also be used on a sensor or contact in an area where immediate notification of an entry is desired.

- Type 06**
24-hour Silent Alarm. This zone type sends a report to the Central Station but provides no console display or sounding. This zone type is usually assigned to a zone containing an Emergency button.
- Type 07**
24-hour Audible Alarm. This zone type sends a report to the Central Station, and provides an alarm sound at the console, and an audible external alarm. This zone type is usually assigned to a zone that has an Emergency button.
- Type 08**
24-hour Auxiliary Alarm. This zone type sends a report to Central Station and provides an alarm sound at the console. **(No bell output is provided).** This zone type is usually assigned to a zone containing a button for use in personal emergencies, or to a zone containing monitoring devices such as water sensors, temperature sensors, etc.
- Type 09**
Supervised Fire. (No Verification) This zone type provides a fire alarm on short circuit and a trouble condition on open circuit. The bell output will pulse when this zone type is faulted. This zone type is always active and cannot be bypassed. **This zone type can be assigned to any wired zone, but only certain wireless systems zones.**
- Type 10**
Interior w/Delay. This zone type gives entry delay (using the programmed entry time), if tripped when the panel is armed in the Away mode. This zone type is also active during maximum mode, but no delay is provided (alarms occur immediately if zone is tripped). **This zone type is bypassed when the panel is armed in the Stay or Instant modes.** Delay begins whenever sensors in this zone are violated, regardless of whether or not an entry/exit delay zone was tripped first.

IMPORTANT! FAULT ANNUNCIATION

RF faults (zones 88–91) will report as trouble conditions only, and as such, should be assigned either zone type 00 if no annunciation is desired, or zone type 05 if annunciation as trouble condition is desired. See "Receiver Fault Annunciation" paragraph in *WIRELESS ZONE EXPANSION* section for more information.

BASIC 8 HARD-WIRED ZONES

Zone 1

The Following Table Summarizes Zone 1 Characteristics.

Applications:	Can be used for EOLR supervised or closed circuit unsupervised devices. It is the only zone that supports 2-wire smoke detectors.
Zone Response Type:	Any
Response Time:	350 msec
Max. Zone Resistance:	100 ohms, excluding EOLR
Unsupervised Usage:	<ul style="list-style-type: none"> • Zone 1 should not be programmed as a fire zone. • Program Field *41 as a "1" (normally closed loops). • Cut Red PCB jumper. • Closed circuit burglary devices must be connected in series with one another, with the series circuit starting at terminal 10 and returning to terminal 12. No EOLR is used across zone 1. • Field 1*46 (AUX Output Enable) may be set to "0" (Ground Start) or "1" (Open/Close Trigger).
EOLR Supervised:	<ul style="list-style-type: none"> • Program Field *41 as a "0" (EOLR required). • Leave Red PCB jumper intact. • Open circuit burglary devices must be connected in parallel across terminals 9 and 10. A 2,000 ohm EOLR must be connected across the furthest device. • Open circuit devices must be connected in parallel across terminals 9 and 10. A 2,000 ohm EOLR must be connected across the furthest device. • Field 1*46 (AUX Output Enable) must be set to "3" (zone 1 EOLR).

**Zone 1
(Cont)**

EOLR Fire Zone:	<ul style="list-style-type: none"> • Program Zone 1 as a Fire zone (type 09). • Program Field *41 as a "0" (EOLR required). • Leave Red PCB jumper intact. • Supports up to eight (8) 2-wire smoke detectors. • Open circuit devices must be connected in parallel across terminals 9 & 10. A 2000 ohm EOLR must be connected across the furthest device. • Connect closed circuit devices in series with the loop. • Field 1*46 (AUX Output Enable) may be set to "3" (zone 1 EOLR) • Second OFF sequence momentarily interrupts the loop power to reset the smoke detectors. • See table below for compatible smoke detectors.
------------------------	--

Compatible Smoke Detectors	
Detector Type	Device Model #
Photoelectric w/heat sensor, direct wire.....	System Sensor 2300T
Photoelectric, direct wire	System Sensor 2400
Photoelectric w/heat sensor, direct wire.....	System Sensor 2400TH
Photoelectric w/B401B base	System Sensor 2451
Photoelect. w/heat sensor & B401Bbase.....	System Sensor 2451TH
Ionization, direct wire	System Sensor 1400
Ionization w/B401B base	System Sensor 1451
Photoelectric duct detector w/DH400 base.....	System Sensor 2451
Ionization duct detect. w/DH400 base	System Sensor 1451DH

Zone 1 Advisories

If the EOLR is not at the end of the loop, the zone is not properly supervised. The system may not respond to an open circuit within the zone.

The alarm current provided by this zone is sufficient to support operation of only one detector in the alarmed state.

UL NOTE: EOLRs are required for UL installations

Zones 2-8

The Following Table Summarizes Zones 2-8 Characteristics.

Applications	Can be used for EOLR supervised or closed circuit unsupervised devices. Can also support 4-wire smoke detectors. Zone 8 can support latching glass break detectors.
Zone Response Type	Any.
Response Time	Zones 1-7: 350 msec; Zone 8: optional 10-15 msec (as programed (field *14)
Max. Zone Resistance	• Zones 2, 3, 4, 5, 7, 8: 300 ohms, excluding EOLR. Zone 6: 100 ohms.
Unsupervised Usage	• EOLR disabled in field *41 (enter 1). • Only closed circuit devices can be used.
EOLR Supervised	• EOLR enabled in field *41 (enter 0). • Supports both open circuit and closed circuit devices. • Connect open circuit devices in parallel across the loop. The 2,000 ohm EOLR must be connected across the loop wires at the last device . • Connect closed circuit devices in series with the loop.
Glass Break Devices on Zone 6	• Supports up to 50 2-wire latching type glass break detectors. • Configure as EOLR zone. • Second CODE + OFF sequence momentarily interrupts power to reset the glass break detectors. • See table that follows for compatible detectors.

(Continued over)

Zones 2-8 (Cont)

Smoke Detectors on Zones 2-8

- Supports as many 4-wire smoke detectors as can be powered (see UL Note on next page).
- Assign zone response type 09 (fire).
- The zones must be configured for EOLR supervision.
- A normally-closed, momentary switch must be installed in series with the power to the detectors in order to allow reset of the smoke detectors after an alarm.
- The detectors must be wired in parallel, with the EOLR at the last detector for full supervision.
- To supervise power, a System Sensor No. A77-716 EOL Relay Module is recommended.

Compatible Glass Break Detectors

Use detectors that are compatible with the following ratings:

Standby Voltage: 5VDC - 13.8VDC
 Standby Resistance: Greater than 20k ohms (equivalent resistance of all detectors in parallel)
 Alarm Resistance: Less than 1.1k ohms (see note below)
 Alarm Current: 2 mA - 10 mA
 Reset Time: Less than 6 seconds

The IEI 735L series detectors have been tested and found to be compatible with these ratings. Up to 50 IEI 735L detectors, connected in parallel, may be used (the alarm current provided by this zone is sufficient to support operation of only one detector in alarmed state). Follow the manufacturer's recommendations on proper installation. Detectors which exceed 1.1k ohms in alarm, but maintain a voltage drop in alarm of less than 3.8 volts can also be used.

Zones 2-8 Advisories

Use of N.O. or N.C. contacts on the same zone may prevent proper glass break detector operation.

UL NOTE: 4-wire smoke detectors cannot be used in UL installations.

Glass Break Detector Connections

- When using glass break detectors on zone 6, Address 1*57 must be set to "1" or "3". Note that the burglary trigger output is no longer available when glass break detectors are used.
- Pin 6 on TB2 (output trigger connector) must be connected to the high side of zone 6 (terminal 17 on the main terminal block TB1), as shown below.

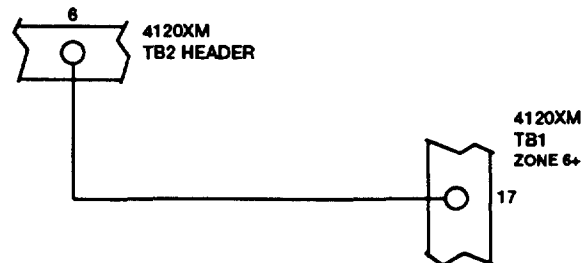

WIRED ZONE EXPANSION

4219 Zone Expander

NOTE:
As shown in Figure 1, the 4219 must be set for Address 2.

- The 4120XM supports up to 8 additional wired zones using one 4219 zone expander. If no 4219 is connected, field 1*58 must be set to 00 (default).
- If a 4219 is used, the 4120XM zone number to be assigned to 4219 zone A is entered in field 1*58. The remaining 4219 zones (B through H) are assigned to the eight 4120XM zone numbers following the one entered in field 1*58. Note that a 4219 uses up to eight 4120XM zones. For example, if field 1*58 is set to 09, then 4219 zones A through H are assigned to 4120XM zones 9 through 16, in that order. Care must be taken that zones assigned to the 4219 do not overlap 4120XM zones 1 through 8, or any zones assigned as wireless.
- Two fields in 1*08 are used to enable and assign zone types for the 4219 supervision and tamper functions.
- Connects to console terminals on control (5, 6, 7, & 8).
- Where possible, the 4219 should be connected to the control using an individual wire run.

For maximum wire lengths when using individual wire runs or multiple units wired on a single run to the control, refer to Table 2 in the section on page 28 entitled *WIRING INFORMATION FOR CONSOLES, RF RECEIVERS, AND OTHER DEVICES*.

For additional information regarding the 4219, refer to the instructions that accompany that unit.

SETTINGS

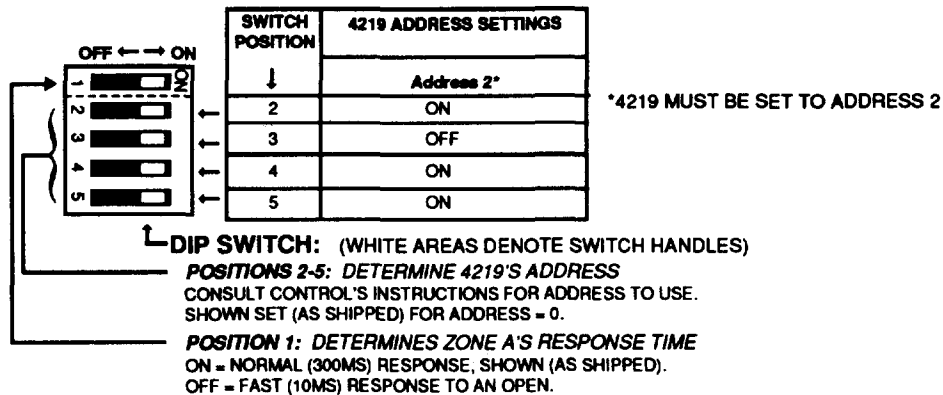

CONNECTIONS

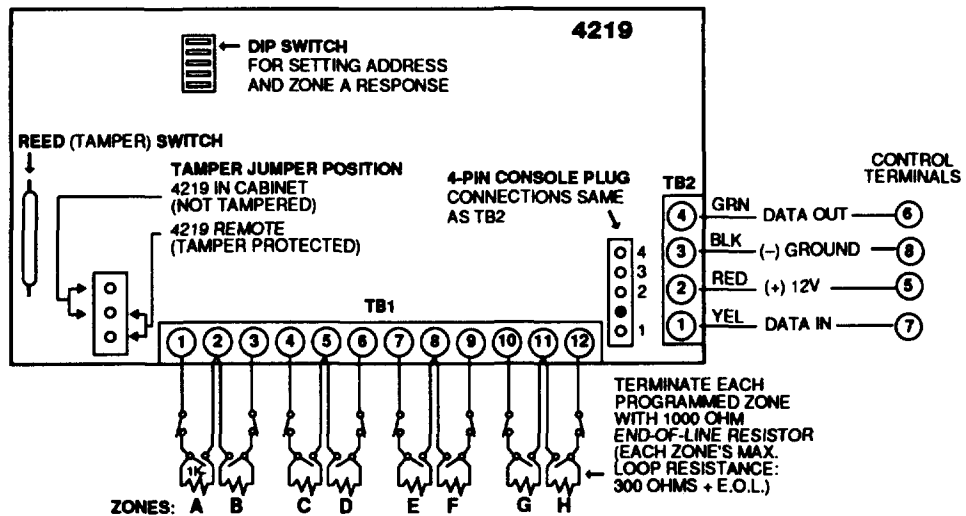

Figure 1. 4219 ZONE EXPANDER

WIRELESS ZONE EXPANSION (Zones 1–63)

General Information (Receivers)

The Following Table Summarizes Wireless Expansion Characteristics.

Transmitters Supported By Various Receivers

Receiver	# of Transmitters
4281H	8
4281M	8
4281L	4

Zones Supported	<ul style="list-style-type: none"> The system supports up to 8 wireless transmitters (5700 series), plus wireless keypads. These can be assigned to any zone between 1 and 63. To expand the system using wireless, one or two 4281-type RF Receivers can be used. Any zone from 1-63 can be used as a 5700 series wireless zone. The total number of transmitters supported by each type of 4281 receiver is shown in the "transmitters supported" table at the left.
4281 RF Receiver (General)	<ul style="list-style-type: none"> The 4281-type RF receiver will respond to status and alarm signals from wireless transmitters (345MHz USA; 315MHz Canada) within a nominal range of 200 feet, and relays this information to the control. Two of the same type of receivers can be used to provide either a greater area of coverage, or to provide redundant protection. Receivers must be mounted externally to the control. <i>See UL note below.</i> The 4281 receiver is connected to the console data lines.
Receiver Supervision	<ul style="list-style-type: none"> If the connection is broken between the receiver and the control panel, a TROUBLE will be displayed for zones 89 or 91 (if type 05 is assigned). In addition, all zones associated with the RF device will report a trouble condition. If, within a programmed interval of time, the receiver does not hear from any of its transmitters, a TROUBLE will appear for zones 88 or 90 (if type 05 is assigned).
House Identification	<ul style="list-style-type: none"> Receivers respond only to transmitters set to the same house ID (01-31). This prevents system interference from transmitters in other nearby systems. Use Sniffer Mode (described later) to make sure you do not choose a House ID that is in use in a nearby system. 4281 house ID is programmed via field 1*51
Sniffer Mode For House ID (Code + [#] + [2])	<ul style="list-style-type: none"> To check for house IDs being used in nearby systems, set receiver's House ID to "00" (in field 1*51, then enter your "Installer Code" + [#] + [2]. The receiver will now "sniff" out any House IDs in the area and display them. Keeping the receiver in this mode for about 2 hours will give a good indication of the house IDs being used. To exit the Sniffer Mode, simply key your installer code + OFF, then set your house ID to one not displayed in the "Sniffer Mode".

UL NOTE: In UL installations, the 4281 must be mounted within 3 feet of the control.

4281 Series Receivers

- Set house ID via field 1*51. (All transmitters used in the system must be set to this same ID.)
- Set receiver's device address using its DIP switches. Lower numbered address is primary receiver (supervisory fault ID 90, 91). Higher numbered address is secondary receiver (receiver fault ID 88, 89).

The following table highlights the features of the 4281 Receiver.

Wiring	Connects to same terminals on control as consoles (5, 6, 7, & 8).
House ID	Programmed via field 1*51.
Receiver Address	Set via DIP switches.
Cover Removal	Does not cause alarm or trouble.
Go/No Go Mode	Automatic upon entering test mode.
Spatial Diversity	Eliminates nulls and voids. 2nd receiver expands coverage area or provides additional redundancy.

Wiring Runs

Where possible, 4281 RF receiver(s) should be connected to the control using individual wire runs.

For maximum wire lengths when using individual wire runs or multiple units wired on a single run to the control, refer to Table 2 in the section on page 28 entitled *WIRING INFORMATION FOR CONSOLES, RF RECEIVERS, AND OTHER DEVICES*.

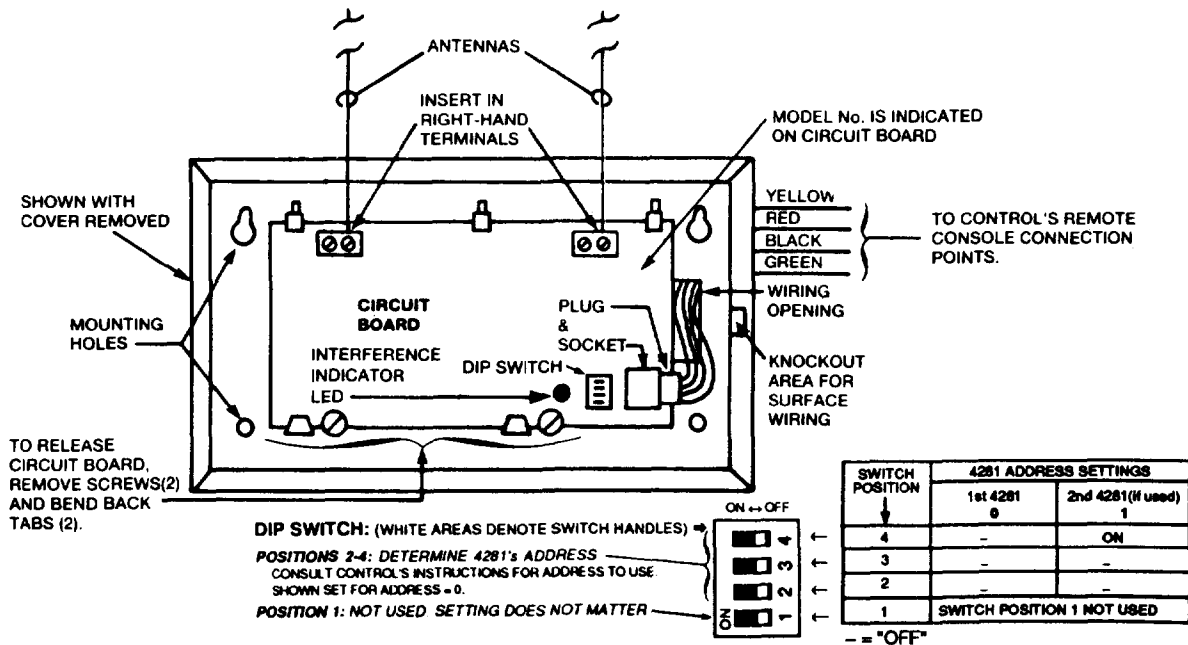

Figure 2. 4281-TYPE RF RECEIVER

5700 Series Transmitters

NOTE:
After replacing a low or dead battery, activate the transmitter and enter the security code + OFF to clear memory of the "Low Battery" signal.

The Following Table Summarizes Wireless Transmitter Characteristics.

<p>Transmitters (General)</p>	<ul style="list-style-type: none"> • System supports 5700 series transmitters. • Each transmitter has its own unique transmitter ID number (Zone #). 5700 series transmitters use DIP switches to set the ID. • 5700 series transmitters must also be set for a house ID. Use the same House ID as that programmed for the 4281(s) in field 1*51 After installation, check that all transmitters have been assigned the proper house ID by using the procedure described later.
<p>Trans. Supervision</p>	<ul style="list-style-type: none"> • Each transmitter (except 5701, 5727) is supervised by a check-in signal that is sent to the receiver at 70-90 minute intervals. If at least one Check-in is not received from a transmitter within a programmed interval (field 1*31), the console will display the transmitter number and "CHECK" will be displayed. • Each transmitter (including 5701, 5727) is also supervised for low battery conditions, and will transmit a low battery signal to the receiver when the battery has approximately 30 days of life remaining. The console will display the transmitter number and "LO BAT" (Alpha consoles) or "BAT" (Fixed-word consoles).
<p>Checking Transmitter Operation (Code + [#] + [3])</p>	<ul style="list-style-type: none"> • To check that all transmitter IDs have been set properly, and that they share the same House ID as the receiver, enter the Installer code + [#] + [3]. • All transmitter ID numbers that have been enabled as wireless zones will be displayed in sequential order. As each transmitter checks in (up to 2 hours), its ID number will disappear. A faster way to do this is to fault each transmitter, which causes a transmission to be sent to the receiver. When all transmitters have checked in, there should be no ID numbers displayed.
<p>"Go/No Go" Test Mode (Patented)</p>	<ul style="list-style-type: none"> • This mode will help determine the best location for each transmitter and is activated by putting the control panel in the TEST mode. • The receiver's sensitivity is reduced by half. Once transmitters are placed in their desired locations and the approximate length of wire to be run to sensors is connected to the transmitter's screw terminals, open circuit each transmitter. <i>Do not conduct this test with your hand wrapped around the transmitter.</i> • If a single receiver is used, the console will beep three times to indicate signal reception. If two receivers are used, the console will beep once if the first receiver received the signal, twice if the second receiver received the signal and three times if both receivers heard the signal (which is desirable for redundant configurations). • If the console does not beep, reorient or move the transmitter to another location. Usually a few inches in either direction is all that is required. • To exit this mode, enter the installer code and press OFF. Note that the Receiver's sensitivity is fully restored when this mode is exited.

Wireless Zone Types

Each RF zone can be programmed to respond as any zone type such as ENTRY/EXIT, INTERIOR, PERIMETER, etc. (see the ZONE TYPES section for a complete explanation of each zone type).

RF transmitters may be assigned any ID number in the range of 1 through 63 (depending on their usage). For example, if using a total of 8 wireless zones (with 4281H receiver)*, transmitters could be set for the following ID numbers:

Number of Transmitters Used	Zone Usage	Transmitter ID
One	Entry/Exit Burglary	9
Three	Perimeter Burglary	10, 11, 12
Two	Interior Burglary	32, 33
Two	Fire	48, 49

* Eight (8) is the maximum number of wireless transmitters that can be used in this system with 4281H or M, maximum of four (4) with 4281L.

Desired alarm responses, transmitter ID range available for each response type, and type of transmitter that can be used in each case, can be broken down as shown in the table that follows:

ZONE TYPE	TRANSMITTER ID #
Entry/Exit Burglary	1 thru 47 * (5711, 5715, 5716)
Perimeter Burglary	1 thru 47 * (5711, 5715, 5716)
Interior Burglary	1 thru 47 * (5711, 5715, 5716) 32 thru 47 * (5775)
Fire	48 thru 63 * 5711, 5715, 5716) 48 thru 55** (5706)
24 Hour Panic (silent or audible)	48 thru 63* (5711, 5715, 5716) 62 or 63 *** (5701) 99 (5727)***
Day/Night Burglary	1 thru 47 * (5711, 5715, 5716)
24 Hour Auxiliary	1 thru 47 * (5711, 5715, 5716)

NOTES:

* Note that zones 1-63 can be used, but have the following limitations: Transmitters set for zones 48-55 will transmit once every 12 seconds while the zone is faulted. Transmitters set for zones 56-63 will transmit once every 3 seconds while faulted. These two ranges of zone numbers could adversely affect transmitter battery life. Transmitters set for an ID of 32 through 47 will have a 3-minute lock-out between transmissions. Use this last range of zone ID numbers for sensors protecting frequently used doors or windows to conserve battery life.

** Transmitter IDs 48 through 55 have highest signal priority.

*** Transmitter IDs 62 and 63 are unsupervised to allow removal of the 5701 off premises – signal priority is lower than that of fire, but higher than burglary.

Advisories

- Do not place transmitters on or near metal objects. This will decrease range and/or block transmissions.
- Place the receiver in a high, centrally located area for best reception. Do not place receiver on or near metal objects.
- For maximum range, the RF receiver must be at least 10 feet from the Control panel or any remote consoles to avoid interference from their microprocessor.
UL NOTE: For UL Household Burglary Installations, wired loops connected to these devices cannot exceed 3 feet.
- If dual receivers are used:
 - Both must be at least 10 feet from each other, as well as from the Control panel and remote consoles.
 - The receiver addresses must be different (1 and 2). See Table in Figure 2.
 - Using two Receivers **does not** increase the number of transmitters the system can support (up to 8 transmitters, plus wireless keypads).

Receiver Fault Annunciation

Annunciating the failure of the RF receiver(s) is as follows:

Faults (for zones 88-91) will report as trouble conditions only, and as such, should be assigned either zone type 00 if no annunciation is desired, or zone type 05 if annunciation as trouble condition is desired. If the RF link fails, the corresponding zone number will display a trouble condition for the device that failed. In addition, all zones associated with that device will indicate a fault condition.

Important Battery Notice

The wireless transmitters are designed to provide long battery life under normal operating conditions. Longevity of batteries may be as much as 4-7 years depending on the environment, usage, and the specific wireless device being used. External factors such as humidity, high or low temperatures, as well as large swings in temperature may all reduce the actual battery life in a given installation. The wireless system can identify a true low battery situation, thus allowing the dealer or user of the system time to arrange a change of battery and maintain protection for that given point within the system.

Button type transmitters (5701) should be periodically tested by the installer for battery life.

Compatible 5700 Series Wireless Devices

- | | |
|---|--|
| 5701 Panic Transmitter | <ul style="list-style-type: none">• Programmable for either silent or audible 24 hour alarm (can be DIP switch programmed for zones 62 or 63). |
| 5711 Slimline Door/Window Transmitter | <ul style="list-style-type: none">• Can be used with any open or closed circuit sensor (selectable). Can be used on any zone 1-63 but, if set for zones 32-47, there will be a 3 minute lock-out between transmissions. |
| 5711WM Door/Window Transmitter w/Reed Switch | <ul style="list-style-type: none">• Slimline door/window transmitter with built-in reed switch (magnet included). Can be used with any closed circuit sensor. Can be used on any zone 1-63 but, if set for zones 32-47, there will be a 3 minute lock-out between transmissions. |
| 5715WH Universal Transmitter | <ul style="list-style-type: none">• DIP switch selectable for fast response, open or closed circuit sensor usage, and has a tamper protected cover. Use in applications where open circuit heat detectors are needed or where fast response devices are needed. Can be used on any zone 1-63 but, if set for zones 32-47, there will be a 3 minute lock-out between transmissions. |
| 5727 Wireless Keypad | <ul style="list-style-type: none">• Wireless keypad that can be used to turn the burglary protection on and off, and features the same built-in panic functions as wired consoles for either silent or audible 24 hour alarm. An LED indication lights each time a key is pressed to verify transmission (LED located in the [*] READY key).• The keypad is identified as zone "00" when it transmits low battery messages. The keypad panics are identified in the same way as wired console keypad panics (i.e. 95, 96 & 99). |
| 5716 Door/Window Transmitter | <ul style="list-style-type: none">• Can be used with any open or closed circuit sensor (DIP switch selectable), and features a built-in reed switch. Can be used on any zone 1-63 but, if set for zones 32-47, there will be a 3 minute lock-out between transmissions. |
| 5775 Wireless PIR | <ul style="list-style-type: none">• The 5775 is a battery-operated, wireless, dual element passive infrared motion detector with built-in selectable pulse count, that can be monitored by a 4281 wireless receiver, and is DIP switch programmable for zones 32-47.
NOTE: There is a 3 minute lock-out between transmissions to preserve battery life. |
| 5706 Wireless Photoelectric Smoke Detector | <ul style="list-style-type: none">• One-piece smoke detector with built-in transmitter (DIP switch programmable for zones 48-55). Built-in UL Listed 85 dB piezoelectric alarm sounder and audible low battery warning. |
| 5707 Wireless Photoelectric Smoke Detector (ESL) | <ul style="list-style-type: none">• One-piece, dual battery smoke detector with built-in transmitter (DIP switch programmable for zones 48-55). Built-in UL Listed 85 dB piezoelectric alarm sounder and audible low battery warning. |

VOLTAGE TRIGGER OUTPUTS (Connector TB2)

(For LORRAs, STUs, Remote Console Sounder, Remote Keyswitch)

General Information

TB2 provides 3 trigger outputs for operating the 4146 Keyswitch, triggering auxiliary alarm sounding equipment (LORRAs, STUs, etc.), and for resetting latching glass break detectors on zone 6.

The pin assignments for TB2 connector are shown below Use only the SA4120XMP-2 trigger cable or the SA4120XM-2 trigger cable, as shown on the following page.

- Outputs 1 and 2 are open collector outputs with a series resistance of 220 ohms.
- Output 3 is an open collector output with no series resistance. Be careful not to short Output 3 to any voltage pins or connections.

UL NOTE:
The 4146 Keyswitch is not approved for use in UL installations.

TB2 TRIGGER CONNECTOR ASSIGNMENTS

Pin 1: AUX POWER

Pin 2: KEY

Pin 3: OUT 1 – FIRE/ARMED LED

Pin 4: **Not Used**

Pin 5: OUT 2 –PANIC/READY LED/REMOTE SOUNDER

Pin 6: OUT 3 – BURG/GLASSBREAK RESET

Pin 7: **Not Used**

Pin 8: GROUND (-)

The table below describes the operation of the 3 output triggers. Address 1*57 determines the trigger operation mode. Note that to use the 4146 Keyswitch, only trigger modes "0" and "1" may be used.

ADDRESS		Trigger Output 1	Trigger Output 2	Trigger Output 3
1*57 Trigger Mode	*15 Keyswitch			
0	0	FIRE LRR TRIGGER	PANIC LRR TRIGGER	BURG LRR TRIGGER
	1	KEYSWITCH ARMED LED	KEYSWITCH READY LED	
1	0	FIRE LRR TRIGGER	PANIC LRR TRIGGER	ZONE 6 GLASS BREAK RESET
	1	KEYSWITCH ARMED LED	KEYSWITCH READY LED	
2	0 1 not allowed	FIRE LRR TRIGGER	REMOTE SOUNDER	BURG LRR TRIGGER
3	0 1 not allowed	FIRE LRR TRIGGER	REMOTE SOUNDER	ZONE 6 GLASS BREAK RESET

NOTE: IF ADDRESS 1*57 IS SET FOR 2 OR 3, ADDRESS *15 MUST BE 0.

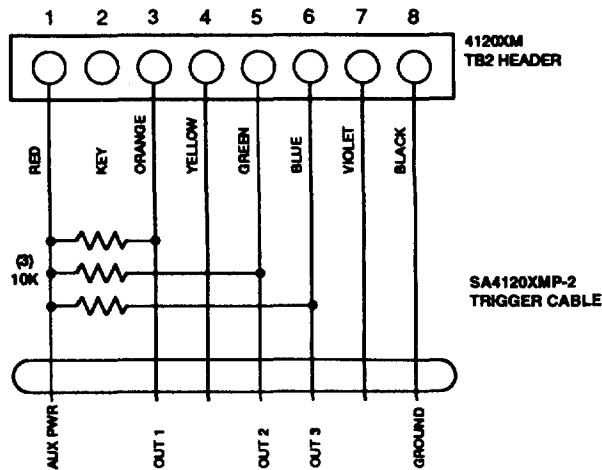

SA4120XMP-2 Trigger Cable with Pull-ups (installer-provided) for use with LORRA.

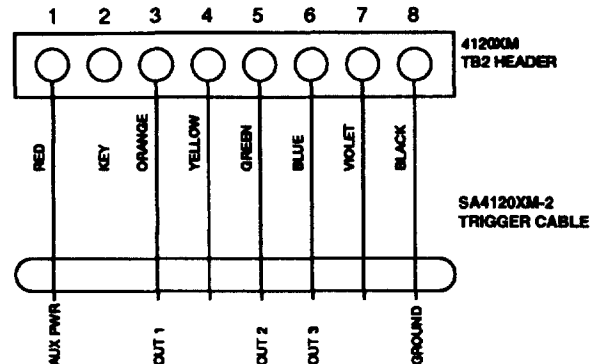

SA4120XM-2 Trigger Cable for use with 4146 Keyswitch & Latching Glass Break Detectors.

REMOTE CONSOLE SOUNDER

Application An optional Amseco PAL 328N piezo sounder can be used for installations where it is desired to remote the sounds produced by the console's built-in sounder. The control panel will remote all sounds (i.e., alarm, trouble, chime, entry/exit, etc.) produced by the console except for the short key clicks associated with console key depression.

One application of this feature might be to produce chime sounds in a location which is distant from the console(s).

Programming & Wiring

If used, Address 1*57 must be set to "2" or "3", and the PAL 328N must be connected to TB2 pin 5, as shown in the diagram below.

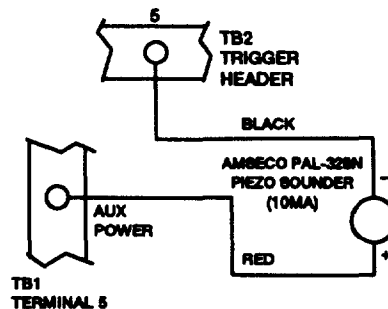

REMOTE KEYSWITCH USAGE

See Figure 3

The 4146 Keyswitch is not approved for use in UL installations.

If the keyswitch option is selected (field *15), the alarm trigger outputs are disabled.

- An optional remote 4146 keyswitch can be used for remote arming and disarming of the system. If used, program field *15 must be set to "1" to enable the keyswitch option.
- The 4146 keyswitch's normally open momentary switch and LEDs must be connected to Zone 7 and to the TB2 connector trigger outputs respectively.
- A 2000 ohm EOL resistor must be connected across the momentary switch, *and zones 2-8 must be programmed for EOLR supervision (0) in field *41.*
Note: In view of the above, all zones must be used with EOLR supervision when a remote keyswitch is used.
- A momentary short across this zone will arm the system in the "AWAY" mode. If the short is held for more than 3 seconds, the system will arm in the "STAY" mode. (i.e., all zones designated as zone types 4 or 10 will be automatically bypassed). After the system has been armed, the next time zone 7 is shorted, the system will disarm.

- An optional closed-circuit tamper switch (model 112) can be wired in series with zone 7, so that, if the switchplate is removed from the wall, the tamper will open, disabling keyswitch operation until the system is next disarmed from the console.

Note: Only one keyswitch with LEDs can be supported by the system's power supply.

LED indications are defined as follows:

GREEN	RED	MEANING
OFF	OFF	DISARMED & NOT READY
ON	OFF	DISARMED & READY
OFF	ON STEADY	ARMED AWAY
OFF	SLOW FLASH	ARMED STAY
OFF	RAPID FLASH	ALARM MEMORY

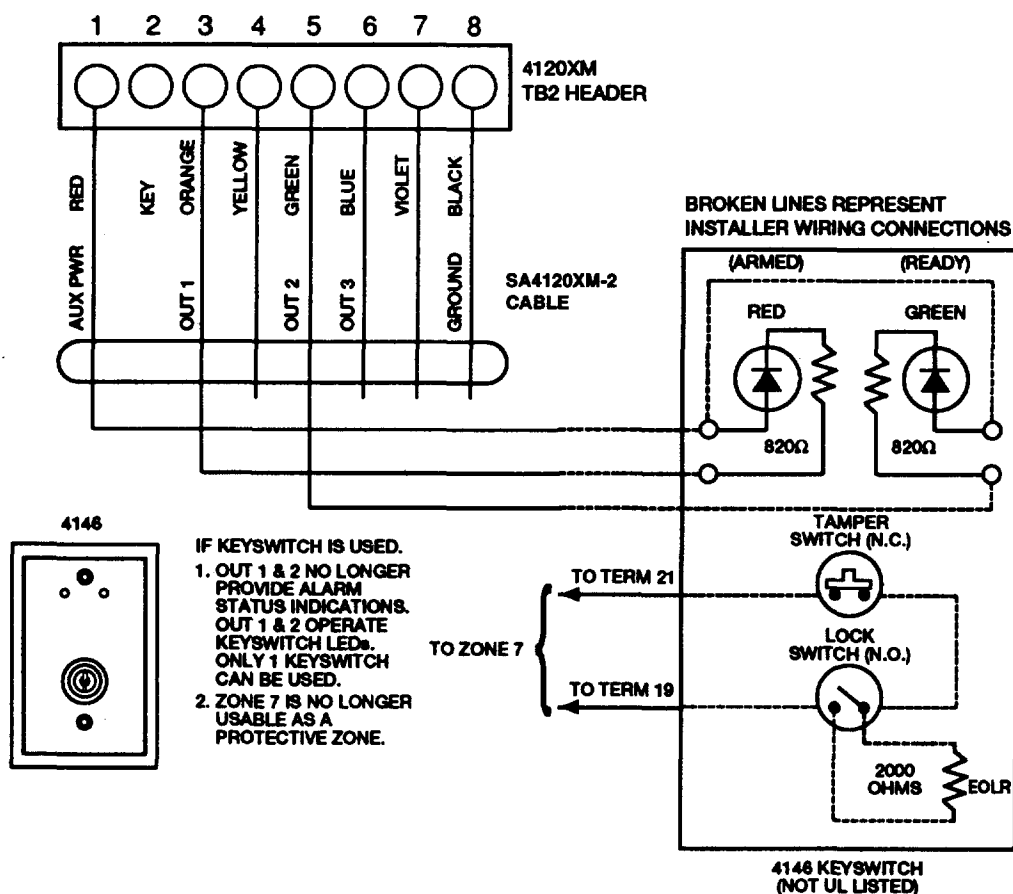

KEYSWITCH PROGRAMMING NOTES:

If a keyswitch is used, note the following:

- Program field *15 must be set to "1" to enable the keyswitch option.
- A 2000 ohm EOLR must be connected across the momentary switch, and zones 2-8 must be programmed for EOLR supervision ("0") in field *41.
- For keyswitch operation, Field 1*57 (Trigger Mode) must be set for either "0" or "1".

NOTE:
THE LOCK SWITCH SHOWN ABOVE (PART OF 4146) IS A NORMALLY OPEN, MOMENTARY (SPRING-LOADED) SWITCH.

Figure 3. REMOTE KEYSWITCH WIRING

Section 3.

REMOTE CONSOLES, EXTERNAL SOUNDERS & PHONE CONNECTIONS

REMOTE CONSOLES

General

The Control supplies up to 700 mA (400 mA for UL) of auxiliary power for remote consoles, and other auxiliary devices such as motion detectors or 4-wire smoke detectors.

IMPORTANT NOTE:
If addressable consoles are used in this system, they **MUST** be set to the non-addressable mode.

Note: 4-wire smoke detectors cannot be used in UL Listed applications.

The Control supports, *independent of auxiliary power considerations*, up to six (6) consoles. This is the maximum that the system can support on the data lines, even if there are no other devices drawing power from the auxiliary output on the control.

The following types of consoles can be used in the system:

Console Type*	Current Draw
4127 or 6127	20 mA
4137AD †	60mA
5137AD/ADR †	90 mA
6137 †	85 mA
6139 †	100 mA

* Console types may be mixed in a system.

† These are addressable consoles, *but must be set to the non-addressable mode in this system.*

Consoles can be powered from the auxiliary power output ***provided that the total current drawn from this output does not exceed 700 mA (400 mA for UL)***. Keep this in mind when adding remote consoles so you don't overdraw current from the control. This would result in a battery which does not charge properly or possibly a tripped auxiliary solid state circuit breaker.

If the total auxiliary load is determined to be greater than 700 mA (400 mA for UL), then additional consoles can be powered from a separate power supply. Refer to the POWERING ADDITIONAL CONSOLES paragraph for a diagram that shows how to make connections to the separate power supply.

4127 Non-Addressable Fixed-Word Console

Compact design, equipped with a liquid crystal display (LCD) using 2-digit numerics for zone identification, and a set of pre-designated English language prompts, such as "READY", "NOT READY", etc. for system status. A built-in alarm sounder is also included, which eliminates the need for a separate indoor sounder.

4137AD Addressable Fixed-Word Console

Equipped with a liquid crystal display (LCD) using 2-digit numerics for zone identification, and a set of pre-designated English language prompts, such as "READY", "NOT READY", etc. for system status. Keys are backlit. A built-in alarm sounder is also included, eliminating the need for a separate indoor sounder. DIP switch selectable ID number. ***Must be set to the non-addressable mode in this system (Address 31).***

5137AD Addressable Alpha Console

Equipped with a programmable 2-line, 32-character (16 characters per line), backlit alphanumeric LCD for complete zone identification in English language (if descriptors are programmed). Keys are also backlit. An alarm sounder is built in, eliminating the need for a separate indoor sounder. DIP switch selectable ID number. ***Must be set to the non-addressable mode in this system (31).***

6137 Addressable Fixed-Word Console

The 6137 Console is keypad addressable (no DIP switches), and features a red "ARMED" LED which lights when the system is armed, and a green "READY" LED which lights when the system is ready to be armed (no zone faults present). This console also features display backlighting, a keypad which is continuously backlit for ease in use and located behind a flip-down decorative door. Also featured are dedicated panic keys, labeled A, B, & C (the D key is not used), ***.Must be set to the non-addressable mode in this system (Address 31).***

6139 Deluxe Addressable Alpha Console

The 6139 Remote Console is keypad addressable (no DIP switches) console, and features a red "ARMED" LED which lights when the system is armed, and a green "READY" LED which lights when the system is ready to be armed (no zone faults present). This console also features display backlighting. The keypad, which is continuously backlit for ease in use, is located behind a flip-down decorative door. The keypad also features dedicated panic keys, labeled A, B, & C (the D key is not used). **Must be set to the non-addressable mode in this system (Address 31).**

The console can be surface mounted directly to a drywall, or to a single or double gang electrical box. For flush mounting to drywall, use the optional 6139TRK flush mount kit.

Mounting The Consoles

Note that field wiring to the consoles must be completed before the consoles can be mounted.

The consoles can be either surface mounted or flush mounted (using an appropriate Trim Ring Kit: 5137TRK or 6139TRK). Refer to the mounting instructions and template included with the console and/or trim ring kit for specific information.

Be sure to take the height of the users into account when mounting consoles.

Wiring Consoles

If convenient, consoles should be wired on individual wire runs to the control. For maximum wire lengths when using individual wire runs or multiple units wired on a single run to the control, refer to Table 2 in the section on page 28 entitled *WIRING INFORMATION FOR CONSOLES, RF RECEIVERS, AND OTHER DEVICES*.

Powering Additional Consoles

As indicated previously, all consoles can be powered from the auxiliary power output provided that the 700mA rating is not exceeded for all devices drawing power from the auxiliary output. The backup battery will supply power to these consoles in the event that AC power is lost.

If necessary, additional consoles can be connected to the system by using a regulated, 12VDC power supply (e.g., 487-12 supplies 12V, 250mA; 488-12 supplies 12V, 500mA). Use a UL Listed, battery-backed supply for UL installations.

Connect the additional consoles as shown at left, using the console wire colors shown. Be sure to observe the current ratings for the power supply used.

IMPORTANT: Make connections directly to the screw terminals as shown. Make **no connection** to the console blue wire.

The 487-12/488-12 power supplies have a backup battery which can power these consoles in the event of AC power loss. Note that consoles powered from supplies which do not have a backup battery **will not function** when AC power is lost. In this case, be sure to power at least one console from the Control's auxiliary power output.

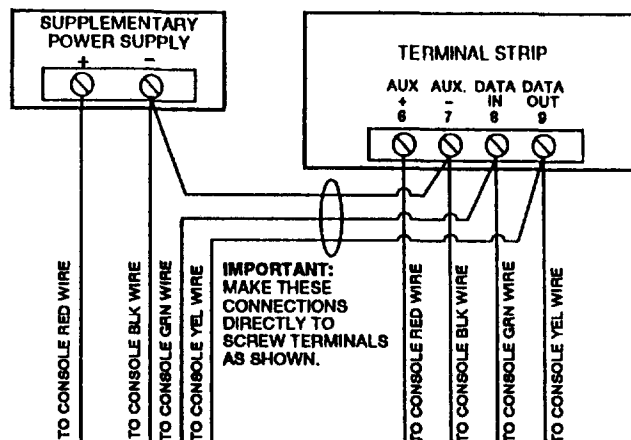

EXTERNAL SOUNDERS

- Relay Output** The 4120XM provides a wet bell relay output which is used to power external alarm sounders. Connections are made to terminals **3** (positive output) and **4** (negative return). See SUMMARY OF CONNECTIONS Diagram.
- UL Installations** For UL installations, the total current drawn from this output and the auxiliary power output, *combined*, cannot exceed 700 mA. In addition, the sounding device must be a UL Listed audible signal appliance rated to operate in a 10.2-13.8 VDC voltage range, and must be mounted indoors. Example: Wheelock Signals Inc. siren model 34T-12 (provides 85dB[A] for NFPA 74 & Standard 985).
- Non-UL Installations** The total current drawn from this output cannot exceed 2.8 amps. A battery must be installed since this current is supplied by the battery. Up to two 702 sirens can be used, wired in series. Up to two 719 sirens can be used, wired in parallel.

IMPORTANT: Going beyond the limits indicated above will overload the power supply or may possibly trip the bell output thermal circuit breaker.

COMPATIBLE SOUNDERS

- 702 Outdoor Siren**
- Self-contained siren (driver built-in) and weatherproof for outdoor use. Can be wired for either a steady or yelp sound and is rated at 120 dB @ 10 feet. This siren can also be tamper protected, or can be mounted in a metal cabinet (716), which can be tamper protected.
- 719 Outdoor Siren (Compact)**
- Compact, self-contained siren (driver built-in), and weatherproof for outdoor use. Can be wired for a steady or yelp sound, and rated at 90 dB @ 10 feet. A tamper protected 708BE cabinet is available.
 - Compact high intensity sounder rated at 123 dB @ 10 feet. This sounder emits an 'ear piercing', high frequency sound, and can be mounted indoors (bracket included) or outdoors (in 708BE cabinet).
- 740 High Intensity Sounder**
- AMSECO motor bell & box, rated at 81 dB @ 10 feet.
- ABB1031 Motor Bell & Box**
- BRK indoor piezo sounder (red or beige), rated at 90 dB @ 10 feet.
UL NOTE: Use only UL Listed sounding devices for UL installations.
- PA400B (beige)/PA400R (red) Indoor Piezo Sounder**

PHONE CONNECTIONS

Phone Line Connections

Incoming phone line and handset wiring is connected to the main terminal block (via a RJ31X jack) as follows (refer to Figure 4 and the SUMMARY OF CONNECTIONS diagram):

- Term. 22: Local Handset (TIP – Brown*)
- Term. 23: Local Handset (RING – Gray*)
- Term. 24: Incoming Phone Line (TIP – Green*)
- Term. 25: Incoming Phone Line (RING – Red*)

* Colors of wires in RJ31X (CA38A in Canada) telephone wall jack.

Warning: To prevent the risk of shock, disconnect phone lines at the telco jack before servicing the control.

If you wish to connect the control to phone lines that require ground start capability, a **675 Ground Start Module** must be used. This module is triggered by a triggered output (terminal 9) on the control. See *GROUND START MODULE* paragraph.

PABX

Important! If the communicator is connected to a telephone line inside a PABX, be sure the PABX has a back-up power supply that can support the PABX for 24 hours. Many PABXs are *not* power backed up and connection internally to such a PABX will result in a communication failure if power is lost.

Ground Start Module

Not intended for use in UL Listed applications.

An optional 675 Ground Start module can be used for installations having telephone lines which require ground start instead of loop start operation to obtain dial tone from the telco central office. If used, program field 1*46 must be set to "0" and the 675 Ground Start Module must be connected to the control's terminal 9 (zone 1 high side)*, to auxiliary power, and to the "RING" side of the telephone line as shown in Figure 5 .

* Wired Zone 1 cannot then be used as a protection zone.

Use the following procedure to determine which side of the telephone line is the "RING" side:

- Connect the "+" lead of a DC voltmeter to earth ground, and the "-" lead to one side of the telephone line.
- The wire which reads +50VDC is the "RING" side.

When the control has a message to transmit to the central station, it will seize the line, go off hook, and then trigger the 675 module to connect the "RING" side of the telephone line to earth ground. The control will cause the module to break the connection between "RING" and earth ground when a dial tone is obtained.

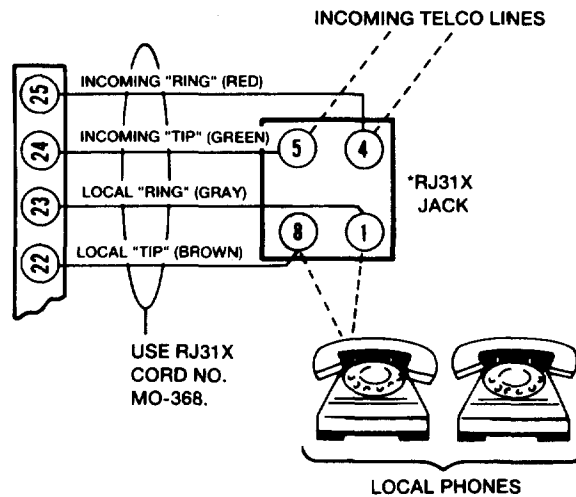

Figure 4. PHONE LINE CONNECTIONS

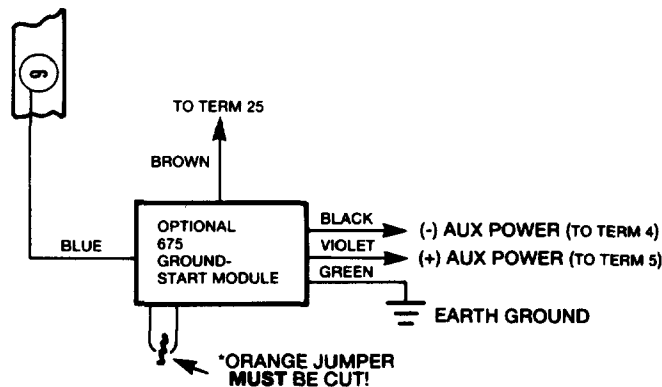

Figure 5. GROUND START CONNECTIONS

Section 4.

MOUNTING THE CABINET, PC BOARD & LOCK

Mounting the Control Cabinet

The 4120XM is supplied with a 12.5"W x 14.5"H x 3"D cabinet suitable for use in residential and non-certified commercial burglary installations.

Mount the Control cabinet to a sturdy wall using fasteners or anchors (not supplied). Install in a clean, dry area which is not readily accessible to the general public. The back of the Control cabinet has 4 holes for this purpose.

Install the PC board and cabinet lock only after the cabinet is mounted.

Mounting The PC Board

Before mounting the PC board, be certain that the appropriate metal knockouts have been removed. **DO NOT ATTEMPT TO REMOVE THE KNOCKOUTS AFTER THE PC BOARD HAS BEEN INSTALLED.**

1. Hang the three mounting clips on the raised cabinet tabs. Observe proper clip orientation to avoid damage to the clip when mounting screws are tightened, and to avoid problems with insertion and removal of the PC board.
2. Insert the top of the PC board into the slots at the top of the cabinet. Make certain that the board rests in the slots as illustrated in step 2 detail (Fig. 6).
3. Swing the base of the board into the mounting clips and secure the board to the cabinet with the accompanying screws, as illustrated in step 3 detail.

Advisory

Make certain that the mounting screws are reasonably tight to ensure a good ground connection between the PC board and the cabinet. Also, dress field wiring away from the microprocessor (center) section of the PC board. The cabinet provides 2 loops on its left and right sidewalls for anchoring field wiring using tie wraps. These steps are important to minimizing the risk of panel RF interference with television reception.

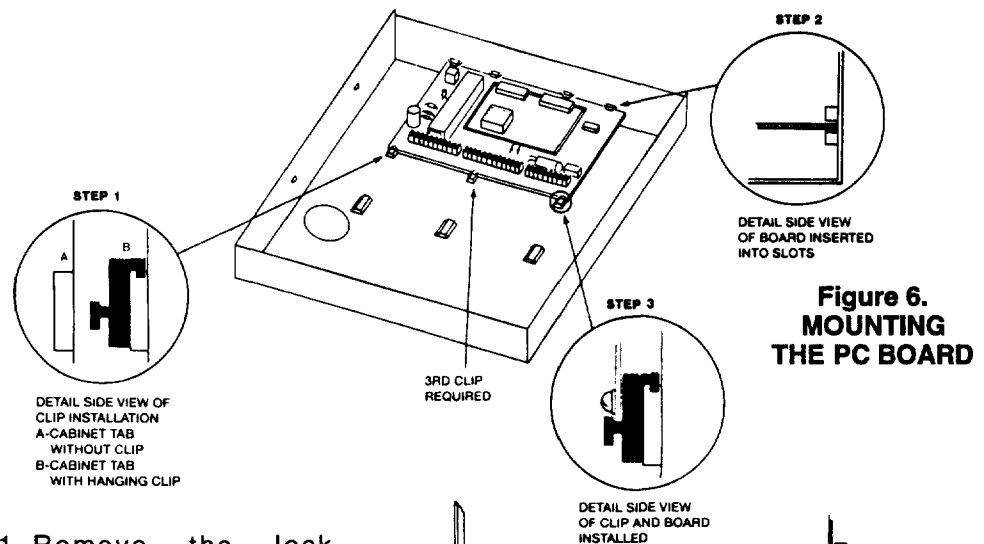

Figure 6.
MOUNTING
THE PC BOARD

Mounting The Cabinet Lock

1. Remove the lock knockout on the control cabinet cover. Insert the key into the lock. Position the lock in the hole making certain that the latch will make contact with the latch bracket when the door is closed.
2. While holding the lock steady, insert the retainer clip into the retainer slots.

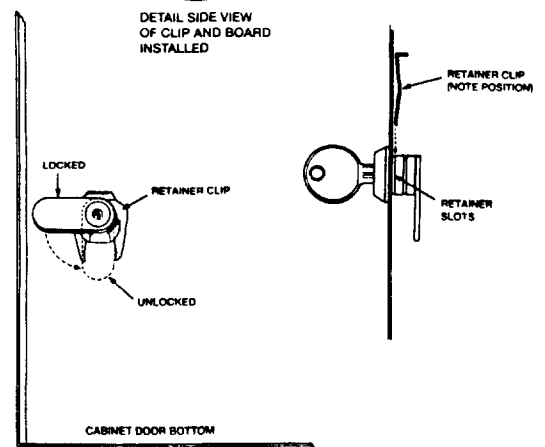

Figure 7. MOUNTING THE CABINET LOCK

Section 5. POWERING THE SYSTEM

POWERING THE SYSTEM

Primary Power Power to the Control panel is supplied by model No. 1321/TF2* Plug-in Transformer which is rated at 16.5VAC, 25VA. Caution must be taken when wiring this transformer to the panel to guard against blowing the fuse inside the transformer (non-replaceable).

* NOTE: Use 1321CN Transformer in Canadian installations.

Back-Up Power In the event of an AC power loss, the Control panel is supported by a back-up, rechargeable gel cell battery. YUASA NP4-12 (12V, 4AH*) and NP7-12 (12V, 7AH) batteries are recommended. **Do not use Gates batteries (sealed lead-acid type).**

* Use 4AH battery for UL installations.

The standby battery is automatically tested every 24 hours, beginning 24 hours after exiting programming mode. In addition, entry into the test mode will cause a battery test to be initiated.

BATTERY STANDBY TABLE

AUX. STANDBY CURRENT DRAW		
AMP-HRS.	400mA	700mA
4.0*	10 hrs.	5.7 hrs.
7.0	15 hrs.	8.5 hrs.

NOTE: These figures are approximate, and may vary depending upon the age, quality, and capacity of the battery at the time of the AC loss.

* Use 4AH battery for UL installations

Earth Ground Connections

In order for the lightning transient protective devices in this product to be effective, the designated earth ground terminal, must be terminated in a good earth ground. The following are examples of good earth grounds available at most installations:

Metal Cold Water Pipe: Use a non-corrosive metal strap (copper is recommended) firmly secured to the pipe to which the ground lead is electrically connected and secured.

AC Power Outlet Ground: Available from 3-prong, 120VAC, power outlets only. To test the integrity of the ground terminal, use a three-wire circuit tester with neon lamp indicators, such as the UL-Listed Ideal Model 61-035, or equivalent, available at most electrical supply stores.

Power-Up Procedure

1. Fill out the AUXILIARY DEVICE CURRENT DRAW WORKSHEET (TABLE 1) provided on the next page. Make sure that the total current drawn by all devices from the Auxiliary output does not exceed its rating of 700 mA (400 mA for UL).

CAUTION: Failure to observe the auxiliary output current rating will result in a battery which does not charge properly or possibly a tripped circuit breaker.

2. Wire the transformer to terminals 1 and 2 on the control (before connecting the battery) as shown in the SUMMARY OF CONNECTIONS diagram. Do not plug in the transformer at this time.
3. Connect all auxiliary devices, such as consoles, zone expanders, RF receivers, PIRs, etc.
4. Plug the transformer into a 24-hour, uninterrupted 120VAC outlet. After a few seconds, the green "POWER" LED* on the console(s) should light and the console(s) should display "READY" (Fixed-word consoles) or "DISARMED....READY TO ARM" (Alpha consoles).

* Some consoles are equipped with a "READY" LED in place of a "POWER" LED.

5. Connect the battery to the battery connector tabs on the PC board (observing correct polarity), as shown in the SUMMARY OF CONNECTIONS diagram.

TABLE 1. AUXILIARY DEVICE CURRENT DRAW WORKSHEET

DEVICE	CURRENT	# UNITS	TOTAL CURRENT
4127 Console	20 mA†		
4137AD Console	60 mA†		
5137AD/ADR Console	90 mA†		
6127 Console	20 mA†		
6137 Console	85 mA†		
6139/6139R Console	100 mA†		
675 Ground Start Module	50 mA		
4281H or 4281M Receiver	40 mA		
4219 Zone Expander	30mA		
*			
*			
TOTAL = (700 mA max.)**			

† Only applies if console is powered from Control terminals **5** & **8** (12V + and -).

* If using hard-wire devices such as PIRs, refer to the specifications for that particular unit's current draw.

** In UL installations, maximum current draw from the Auxiliary Output and the Alarm Output **combined** must not exceed 700 mA.

WIRING INFORMATION FOR CONSOLES, RF RECEIVERS, AND OTHER DEVICES

Maximum Wiring Lengths When Single or Multiple Devices are Connected to a Single Wire Run to the Console Terminals on the Control

If single or multiple units (Consoles, RF Receivers, Zone Expander, etc.) are connected to a single 4-wire run to the console terminals on the control, determine the current drawn by the unit(s) connected to the single wire run, then refer to the Wiring Run chart below to determine the maximum wire length that can be safely used for each wire size.

In some cases, the total current drawn may result in a value not shown in the chart. For example, if you intend to use #22 gauge wire and the total current drawn is 400 mA (a value midway between 300 mA and 500 mA), the maximum wire length you should use is approximately 65 ft (a length midway between 50 and 80 feet). Other maximum wire lengths for values of current not shown in the chart can be calculated in a similar manner.

Maximum wire lengths for a device that is homerun to the control can also be determined from the chart, based on the current draw of that device alone.

**TABLE 2.
WIRING RUN CHART FOR DEVICES* DRAWING POWER FROM THE CONSOLE
TERMINALS ON THE CONTROL (**5** & **8**, 12V+ & Ground Return)**

Wire Size	TOTAL CURRENT DRAWN BY ALL UNITS ON A SINGLE WIRE RUN				
	50 mA or less	100 mA	300 mA	500 mA	700 mA
#22	500 ft (152m)	250 ft (76m)	80 ft (24m)	50 ft (15m)	35 ft (10.6m)
#20	750 ft (228.6m)	380 ft (116m)	130 ft (39.6m)	80 ft (24m)	55 ft (16.8m)
#18	1300 ft (396m)	650 ft (198m)	220 ft (67m)	130 ft (39.6m)	100 ft (30.4m)
#16	2000 ft (609.6m)	1000 ft (305m)	330 ft (100.5m)	200 ft (70m)	140 ft (42.7m)

MAXIMUM WIRE LENGTH

* Includes Remote Consoles, RF Receivers, and Zone Expander.

Note: The length of all wire runs combined must not exceed 1500 feet when unshielded quad conductor cable is used (750 feet if shielded cable is used). This restriction is due to the capacitive effect on the data lines when quad cable is used.

Section 6. SYSTEM OPERATION

SECURITY ACCESS CODES

General Information The System allows up to 70 security access codes to be assigned, each identified by a user ID number. In addition, the Quick Arm feature can also be programmed, which enables the [#] key to be pressed instead of entering the security code when arming the system. The code must still be entered when disarming the system.

Note that Open/Close reporting of Quick Arm is enabled if User 2 is enabled for Open/Close reporting, and that Quick Arm reports as User 0.

Choice of 4-Digit (Standard) or 6-Digit (High Security) Codes The system also offers either standard (4-digit) or high security (6-digit = user # + 4-digits) security codes (selected in field 1*54). If High Security mode is selected, the 2-digit user # followed by the 4-digit code must be entered for all operations (Installer=01, Master code = 02, etc.).

For example, if user 14, whose code is 5678, wishes to disarm the system, the sequence would be 1+4+5+6+7+8 + OFF.

User Codes & Levels Of Authority Each user of the system can be assigned various levels of authority (tells system what system functions that user is authorized to do). In highest to lowest ranking, these levels are described below.

User	Title
1	Installer
2	Master (Primary User)
3	Temporary User

Installer Code (User 1)	<ul style="list-style-type: none"> • Programmed in field *00 (default = 4-1-2-0). Can be changed by installer. • Can perform all system functions (arm, disarm, bypass, etc.) and is the only user that can enter program mode. • Only code that allows entry to program mode. • Installer code lockout if exit program mode via *98. This prevents installer from re-accessing program mode. The only way to access the Programming mode once this feature is activated is by powering down the system and powering up again, and then pressing both the * and # keys at the same time within 30 seconds of power up. • The installer must program the master code. The Master code is intended for use by the primary user of the system. • Can add, delete, or change master codes. • Can perform normal system functions, but cannot disarm if armed by a code other than Installer's code (including Quick Arm).
Master Code (User 2)	<ul style="list-style-type: none"> • As shipped from the factory, the master code is pre-programmed for 1-2-3-4, but can be changed by the installer (in field *01). • The Master Code is the code intended for use by the primary user of the system and allows that user to perform all system functions. • The master code can be used to assign up to 68 temporary codes (for Users 03 through 70), which can be used for other users of the system who don't have a need to know the master code. Each of these user's codes can be individually eliminated or changed at any time. • Master cannot change the Installer's code.

User Codes & Levels Of Authority (cont.)

<p>Temporary Code (User 3)</p>	<ul style="list-style-type: none"> • Can perform all system functions (Arm, Disarm, Bypass, etc.) using the temporary code programmed by User 2 (Master). • May add, delete, change temporary codes for Users 04 through 69 (User3 cannot change User 02's or 70's code).
<p>Duress Code</p>	<ul style="list-style-type: none"> • The duress code is a means of sending a silent alarm to a central monitoring station if the user is being forced to disarm (or arm) the system under threat. This feature is only useful if the system is connected to a central station. • The Duress code is simply the usual security code, but with the fourth digit increased by one (e.g., if code is 1-2-3-4, duress code is 1-2-3-5). • When the system's Auxiliary Voltage Triggers are connected to another communication's media (Derived Channel/Long Range Radio), note that duress is signaled on the same trigger that signals silent panic (whereas duress has its own unique report when digitally communicated). • When used, the system will disarm (or arm), but will also send a silent alarm to the central station (if service is connected). There will be no indication at the console that an alarm was sent.
<p>Babysitter Code (User 22)</p>	<ul style="list-style-type: none"> • This code is usually assigned to those who have a need to arm and disarm the system at specific times only (e.g., a babysitter needs to control the system only when babysitting). • If field 1*50 is enabled, the code assigned to User 22 cannot be used to disarm the system unless the system was armed with that code. • Temporary users, such as babysitters, should not be shown how to bypass zones when arming.

Important!:

Unless Ademco Contact ID reporting is used, only user codes #1 - #15 can uniquely report to the central station using the communication formats provided. Users #16 - #70 will report as User #15, if enabled for open/close reporting, for the other reporting formats.

Assigning or Deleting Temporary Codes By User 2 (Master User)

- The Master or Primary User (User 2) can assign or delete temporary codes for Users 03 through 70.
- User numbers must be entered as 2-digit entries. Single digit user numbers must, therefore, always be preceded by a "0" (example, 03, 04, 05, etc.). Make sure the end user understands this requirement.
- The system will emit a single beep when each temporary code has been successfully entered. If the 6-digit code feature is in effect (field 1*54), temporary users must also use 6-digit codes (2-digit User # + 4-digit code).
- It is recommended that obvious codes, such as 1111 or 1234, not be used.
- When a temporary 6-digit code is inadvertently repeated for different users, or one user's code is another's duress code, the lower user number will take priority (only the lower user number's code is active).
- Do not assign sequential codes 1 digit apart from each other (ex. 4096, 4097, 4098) as this will cause a Duress to be sent each time (one user's code is another user's duress code).

To Assign A Temporary Code:

1. Enter Master Code
2. Press CODE key
3. Enter User # (03-70)
4. Enter 4-digit temporary code to be assigned.

To Delete a Temporary Code:

1. Enter Master Code
2. Press CODE key
3. Enter User # to be deleted
4. Enter Master Code.

Assigning or Deleting Temporary Codes By User 3

- User 3 can only assign or delete temporary codes for Users 04 through 69.

To Assign A Temporary Code:

1. Enter User 3's Code
2. Press CODE key
3. Enter User # (04–69)
4. Enter 4-digit temporary code to be assigned.

To Delete a Temporary Code:

1. Enter User 3's Code
2. Press CODE key
3. Enter User # to be deleted
4. Enter User 3's Code.

CONSOLE KEYPAD FUNCTIONS

General Information

The keypad allows the user to arm and disarm the system, and perform other system functions, such as bypassing zones. On Alpha consoles, the user can also view messages from the central station and display zone descriptors.

Status Displays

On all consoles, zone and system conditions (system ready or not ready for arming, fire and burglary alarms, troubles, bypasses) are displayed in the Display Window.

Four Modes of Burglary Protection

The system provides four modes of burglary protection: STAY, AWAY, INSTANT, and MAXIMUM. See SUMMARY OF ARMING MODES table. In addition, if any zones are faulted prior to arming (NOT READY condition), the console can display them one at a time, and specific zones can be selectively bypassed.

Alarm Sounding & Displays

When an alarm occurs, console sounding and external sounding will occur, and the zone(s) in alarm will be displayed on the console. Pressing any key will silence the console sounder for 10 seconds. Disarming the system (security code + OFF key) will silence both console and external sounders.

Memory of Alarm

When the system is disarmed, any zones that were in an alarm condition during the armed period will be displayed (memory of alarm). To clear this display, simply repeat the disarm sequence (enter the security code and press the OFF key). See RECALLING ALARM & TROUBLE MESSAGES.

Chime Mode

The consoles also include chime annunciation which, when on, will produce 3 short beeps from the console(s) when any zone is faulted (and display that zone).

Panic (Emergency) Keys

Panic keys are provided for emergency situations (which will produce silent, audible, fire or auxiliary alarms), and which will also notify the central station, if that service is connected.

Quick Arm

Note that if QUICK ARM is enabled (in field *29), the [#] key can be pressed instead of entering the security code for any of the arming procedures (Away, Stay, Instant, Maximum).

Arming Functions

Note that if QUICK ARM is enabled (field *29), the [#] key can be pressed instead of entering the security code, for any of the arming procedures (Away, Stay, Instant, Maximum).

The following is a brief list of system commands. For detailed information concerning system functions, refer to the User's Manual.

- Disarmed /Not Ready** Before arming, the system must be in the READY condition (all zones must be intact). If the "NOT READY" message appears, press the READY [*] key to display faulted zones.
- Arming Away** Enter code + AWAY [2].
- Arming Stay** Enter code + STAY [3].
- Arming Instant** Enter code + INSTANT [7].
- Arming Maximum** Enter code + MAXIMUM [4].
- Disarming** Enter code + OFF [1].
- Bypassing Zones** Enter code + BYPASS [6] + zone number.
To automatically bypass all faulted zones, use the "Quick Bypass" method: Enter code + BYPASS + [#].
- Chime Mode** Enter code + CHIME [9]. To turn chime mode off, enter code + CHIME again.

SUMMARY OF ARMING MODES

Mode	Features For Each Arming Mode			
	Exit Delay	Entry Delay	Perimeter Armed	Interior Armed
AWAY	Yes	Yes	Yes	Yes
STAY	Yes	Yes	Yes	No
INSTANT	Yes	No	Yes	No
MAXIMUM	Yes	No	Yes	Yes

Panic Keys

Some consoles make use of three key pairs for panic, while others are equipped with three separate panic keys (see below). If programmed, they can be used to manually initiate alarms and send a report to the central station. Each key pair (or single key) can be individually programmed for 24-Hour Silent, Audible, Auxiliary or Fire responses. The panic function is activated when the appropriate key (or key pair) is pressed. Key pairs must be pressed at the same time.

The panic functions are identified by the system as follows:

Panic Key Pairs	Panic Single Keys	Displayed as Zone
[*] + [1]	A	95
[#] + [3]	C	96
[*] + [#]	B	99

For Alpha consoles, these panic keys can also be programmed with an alpha descriptor.

Important: For the silent Panic functions to be of practical value, the system must be connected to a central station.

Viewing Downloaded Messages (Alpha Consoles Only)

Users may occasionally receive messages on the console display from their installation company. When this occurs, the console will display the following:

"Message. Press 0 for 5 secs."

Instruct the user to press and hold the [0] key to display the central station's message. Note that the system must be in the READY state to view these messages.

Using The Built-In User's Guide (Alpha Consoles Only)

An abbreviated User's Guide is stored in the system's memory, and can be particularly useful to the end user if the printed User's Manual is not conveniently accessible when the user needs to perform a seldom used and unfamiliar system procedure.

The Built-in User's Guide is displayed by simply pressing any of the function keys (e.g., OFF, AWAY, STAY, MAXIMUM, BYPASS, INSTANT, CODE, TEST, READY, #, and CHIME) for approximately 5 seconds and then releasing it. Abbreviated instructions relative to the key that has been pressed will then be displayed (2 lines of text are displayed at a time). This function operates in either the armed or the disarmed state.

Displaying Descriptors (Alpha Consoles Only)

The Alpha Consoles can display all programmed descriptors, which is useful to the installer when checking entries, and can be helpful to the user when there is a need to identify zones.

To display descriptors, press and hold the READY key until the built-in instructions for that key appear, then release the key. The zone descriptors will appear one at a time, for about 2-3 seconds each. For faster viewing, press the READY key to display the next descriptor in numerical order and so on. When all descriptors have been displayed, the Control will exit the display mode. To exit display mode before all descriptors have been displayed, enter the security code and press the OFF key.

Recalling Alarm & Trouble Messages (Memory Of Alarm)

The system's alarm memory retains all events for a period of 10 days, starting at the time of the first event. Upon expiration of the 10-day period, all history is automatically erased and the alarm memory will reset. The next 10-day cycle will begin when the next event occurs.

Recall by service personnel will display all events that have occurred from the start of the 10-day cycle to the time of recall. Note that Recall will end any 10-day cycle in progress. The LCD display on Fixed-word consoles will indicate the number of the zone in which the event occurred (e.g., 01, 02, etc.), accompanied by the word CHECK (trouble), ALARM and, if applicable, FIRE, to describe the type of event that occurred in the displayed zone. If an Alpha console is used, an alpha descriptor of the zone will be displayed in addition to its zone number.

If more than one event had occurred, the events will be displayed in numerical sequence. Each display will appear for 1-2 seconds, then the next event will be displayed. When all events have been displayed, the displays are repeated.

To display 10-day history, enter the security code and press the [0] key. Note that recall will end any 10-day cycle in progress.

To exit recall mode, enter the security code and press the OFF key. All existing history is erased and the alarm memory is reset. The 10-day cycle will start again only when the next event occurs.

TROUBLE CONDITIONS

(Refer also to Section 11. TROUBLESHOOTING)

General

The word "CHECK" on the Console's display, accompanied by a rapid "beeping" at the Console, indicates that there is a trouble condition in the system. The audible warning sound can be silenced by pressing any key. Instruct users to call for service immediately upon seeing any of the following messages.

"Check" Messages

A display of "CHECK" accompanied by a display of one or more zone descriptors (Alpha consoles) or numeric zone IDs (Fixed-word consoles) indicates that a problem exists with those zone(s).

First, determine if the zone(s) displayed are intact and make them so if they are not. If the problem has been corrected, key an OFF sequence (Code plus OFF) to clear the display.

A display of the word "CHECK" accompanied by a numeric display of "81" or "83" indicates a 4219 zone expander problem..

A display of the word "CHECK" accompanied by a numeric display of "88", "89", "90", or "91" indicates a 4281 Receiver problem. Faults "88", "89" "90" & "91" can be assigned alpha descriptors when using an Alpha console.

Other Trouble Conditions

A display of **"COMM. FAILURE"** (Alpha consoles) or **"FC"** (Fixed-word consoles) at the Console indicates that a failure occurred in the telephone communication portion of the system.

A display of **"LO BAT"** (Alpha consoles) with a zone number and descriptor, or **"BAT"** (Fixed-word consoles) with a zone number, and accompanied by a once-per-minute beep at the Console, indicates that a low battery condition exists in the wireless transmitter displayed.

The audible warning sound may be silenced by pressing any key.

A display of **"SYSTEM LO BAT"** (Alpha consoles) or **"BAT"** with no zone ID (Fixed-word consoles) indicates that a low battery condition exists with the system's backup battery.

A display of **"4281 SET UP ERROR"** (Alpha consoles) or **"E8"** (Fixed-word consoles) at the console indicates that a 4281 receiver is being used in a system with more than 8 RF zones programmed. If this is not corrected, none of the zones in the system will be protected.

A display of **"MODEM COM"** (Alpha consoles) or **"CC"** (Fixed-word consoles) indicates that the control is on-line with the remote computer and the control is not operating.

A display of two numbers and **"NO AC"** (Fixed-word consoles) indicates the control is in the programming mode and is not operating.

Power Failure

If the message **"AC LOSS"** (Alpha consoles) or **"NO AC"** (Fixed-word consoles) is displayed, the Console is operating on battery power only.

Check to see that the system's plug-in transformer has not been accidentally pulled out. Instruct the user to call a service representative immediately if AC power cannot be restored.

Section 7. SYSTEM COMMUNICATION

Split/Dual Reporting

Dual reporting (*51) sends all reports to both primary and secondary phone numbers. Split reporting allows reports to be divided between the phone numbers according to the field's (1*34) selections. Split/Dual reporting can be selected by enabling dual reporting and enabling one of the split reporting options in field 1*34. If option [1] is selected, all alarms, alarm restores and cancel reports will go to both phone numbers, while all other reports will go to the secondary phone number. If [2] is selected, open/close and test messages will go to both phone numbers, while all other reports will go to the primary phone number. Following are the Split/Dual Reporting options:

Reporting Format	Field Number		Where Reports Go
	*51	1*34	
Dual	1	0	All reports to both num.
Split	0	1 or 2	1=alarm, alarm restore & cancel to primary, all others to secondary.
			2=open/close, test to secondary, all others to primary.
Split/Dual	1	1 or 2	1=alarm, alarm restore & cancel to both, all others to secondary only.
			2=open/close to both, all others to primary only.

Ademco Low Speed

ADEMCO LOW SPEED is a pulsed format which responds to a 1400 Hz handshake and kiss-off, and transmits data with 1900Hz pulse tones @ 10 pulses per second (pps). A typical message consists of two rounds which must be verified by the receiver. A complete standard report consists of either a 3 or 4-digit account number followed by a 1-digit alarm code. Though 2 rounds are sent, only the valid report is displayed.

In expanded reporting, two messages are sent, two rounds per message, the first being the account number and alarm code, the second being the zone ID code to which the alarm was assigned. A complete expanded report consists of a 3 or 4-digit account number followed by a 1-digit alarm code, then the alarm code is repeated, followed by the channel number.

Example: Standard: CCCC E where: CCCC = account number
 Expanded: CCCC E E = event code
 EEEE Z Z = zone ID code

Sescoa/Radionics

Standard and expanded reporting in the SESCOA/RADIONICS format is virtually the same as ADEMCO Low Speed except for the following:

1. The handshake and kiss-off frequency is 2300 Hz.
2. The data is transmitted with 1800 Hz pulse tones.
3. The rate of transmission is 20 pps.

4+2 Reporting

A 4+2 report consists of a 4-digit account number and a 2-digit alarm code, or event code. 4+2 reports can be accomplished either in ADEMCO Low Speed (10 pps), or SESCOA/RADIONICS (20 pps) format.

In 4+2 reporting a unique 2-digit code for each zone is reported. A 4-digit account number followed by a 2-digit code is sent, where the first digit is the actual event, such as in ALARM, RESTORE, or TROUBLE, etc., and the second digit of the code represents the "zone" where the event occurred. (but not necessarily the actual zone number). Each code in itself is unique to a specific zone. If desired, the actual zone number can be reported by entering the corresponding 2-digit zone number (e.g., zone 1= [0] [1]; zone 63= [6] [3]). A report might appear as:

1 2 3 4 5 9 ("5 9" might be a unique "TROUBLE RESTORE, ZONE 25).

4+2 Express

ADEMCO's Express format provides the same information as the 4+2 format, but with three differences:

1. The data is transmitted in DTMF (Dual Tone Multi-Frequency known as "TouchTone, at the rate of 10 characters per second). This greatly decreases the time it takes a report to go through to central station. An average 4+2 Low Speed report might take as long as 20 seconds to complete its report, but 4+2 Express takes under 3 secs.
2. Two message rounds are eliminated by the use of a checksum digit. Instead of the communicator sending 2 rounds per report, it sends only 1 round with a checksum digit at the end. Doing this also helps in decreasing the time it takes for a report to be sent.
3. The handshake frequency is 1400 Hz followed by 2300 Hz, and the kiss-off frequency is 1400 Hz.

Ademco High Speed Reporting

ADEMCO's High Speed format transmits data in DTMF at a rate of 10 characters per second. The handshake frequency is 1400 Hz followed by 2300 Hz, and the kiss-off frequency is 1400 Hz. The message contains 13 digits as follows: A 4-digit account number + eight channels of zone information (1-8 or duress plus 9-15) + one status channel, which identifies the type of events being reported in the eight zone locations. A typical High Speed report will be kissed off in under 5 seconds.

Channels 1 through 8 could have one of the following conditions:

- 1 = NEW EVENT
- 2 = OPENING (Status Channel Always = 2)*
- 3 = RESTORE
- 4 = CLOSING (Status Channel Always = 4)*
- 5 = NORMAL, NO EVENT TO REPORT
- 6 = PREVIOUSLY REPORTED, NOT YET RESTORED

* NOTE: Channel 1 will contain the user ID 1-9, A-F if Open/Close reporting is enabled.

The status channel might have one of the following conditions:

- 1 = DURESS (For Duress Plus Channels 9-15 Only)
- 2 = OPENING
- 3 = BYPASS (For Channels 1-8 Only)
- 4 = CLOSING
- 5 = TROUBLE (For Channels 1-8 Only)
- 6 = SYSTEM STATUS:
 - AC LOSS in Channel 1
 - LOW BATTERY in Channel 2
 - PROGRAM TAMPER in Channel 3
 - POWER ON RESET in Channel 4
- 7 = NORMAL ALARM STATUS (Channels 1-8 Only)
- 9 = TEST REPORT

A typical high speed report may look as follows:

1234 5115 5555 7 (Acct #1234 with alarms on channels 2 and 3)

High Speed Format Limitations

1. When using Ademco high speed, remember there are only 15 channels available, plus a duress channel. If more than 15 zones are being used, they will have to share channels.
2. With Ademco High Speed reporting, channels 9-15 cannot report troubles or bypasses. Use these channels for zones that will not report these conditions.

Contact ID Reporting

This is the only format that can identify all 64 protection zones by their unique zone (Contact) ID numbers, and provides a 1-digit event qualifier and 3-digit, specifically defined event code which quickly identifies the condition being reported.

Contact ID reports in DTMF (Dual Tone Multi-Frequency @ 10 characters per second) and responds to a 1400 Hz followed by 2300 Hz handshake, and a 1400 Hz kiss-off. This format also uses checksum instead of two message verification. A complete report takes under 3 seconds.

Contact ID Reporting takes the format: CCCC Q EEE GG ZZZ where:

CCCC = Customer (subscriber) number.

Q = Event qualifier, where: E=new event (1) and R= restore (3)

EEE = Event code (3 hexadecimal digits), defined in the table on the next page.

GG = Always 00.

ZZZ = Zone/contact ID number reporting the alarm (001-099), or user number (001-070) for open/close reports. System status messages (AC Loss, Walk Test, etc.) contain zeroes in the ZZZ location.

TABLE OF CONTACT ID EVENT CODES

Code	Definition
110	Fire Alarm
121	Duress
122	Silent Panic
123	Audible Panic
131	Perimeter Burglary
132	Interior Burglary
133	24 Hour Burglary
134	Entry/Exit Burglary
135	Day/Night Burglary
142*	Polling Loop Short Alarm
143	RF Receiver Failure-Alarm
150	24 Hour Auxiliary
301	AC Loss
302	Low System Battery
305	System Reset
306	Program Tamper
309	Battery Test Fail
332*	Poll Loop Short-Trouble

Code	Definition
333	RF Receiver Failure-Trouble
373	Fire Loop Trouble
380	Trouble (global)
381	Loss of Supervision - RF
382*	Loss of RPM Supervision
383*	RPM Sensor Tamper
384	RF Transmitter Low Battery
401	O/C By User
403	Power-Up Armed
406	Cancel by User
407	Remote Arm/Disarm (Download)
408	Quick Arm
409	Keyswitch O/C
411	Call back Requested
570	Bypass
602	Periodic Test
607	Walk Test Mode

* Not applicable to 4120XM system.

ADVISORY:

Ademco's new Contact ID reporting is capable of uniquely reporting all 64 zones of information, as well as openings and closings for all 70 users, to central stations equipped with the Ademco 685 receiver using software level 4.4 or higher. 685 software levels below 4.4 cannot support Contact ID reporting.

For information regarding updating the 685 receiver, or for a detailed listing of all possible Contact ID reports for this panel, contact Ademco's Technical Support group at 1-800-645-7492 (NY) or 1-800-458-9469 (CA).

4120XM COMMUNICATION PROGRAMMING GUIDE

Field #	Low Speed	Contact ID	High Speed	Express
*46, *48	Choose transmission speed and frequency	No effect	No effect	No effect
*52, *53	Send as either 4+2 or expanded	No effect	No effect	No effect
*79, *80	Enables alarm restores	Enables alarm restores	Enables alarm restores	Enables alarm restores
*49	Add checksum digit	No effect	Add checksum digit	No effect
*81, *82	Define codes and selects 4+1 or 4+2	1st digit enables report if it is non-zero	1st digit enables report if it is non-zero	Define codes and selects 4+1 or 4+2
*54, *56, *59, *61, *64, *66, *69, *71, *74, *76	Defines alarm event code	Enables reports	Assigns reporting chnl for all reports from this zone. Enables alarm reporting	Defines alarm event code
*55, *57, *60 *62, *65, *67, *70, *72, *75, *77	Defines code and selects 4+1 or 4+2	No effect	No effect	Defines code and selects 4+1 or 4+2
*58, *63, *68, *73, *78	Enables report and selects code. NOTE: No restores if event not sent.	Enables report	Enables report NOTE: Alarm channel must be programmed. (01-15)	Enables report and selects 1st digit of the 2-digit event code. NOTE: No restores if event not sent.
*50	Sescoa/Radionics; Selects fixed digit time instead of fixed interdigit.	No effect	No effect	No effect
NOTES	Low Speed will not send 3+2 messages. Zone ID digit is suppressed.	If Contact ID is desired, it must be used on both primary & secondary phone #s.	If High Speed is used for secondary, it must be used for primary. If used on primary, any other format can be used on secondary.	

(Continued on page 39)

Section 8. PROGRAMMING THE SYSTEM

Programming Procedures

General **Note:** A tear-out blank programming form has been included at the centerfold of this manual.

The system is shipped with a set of pre-programmed values that are designed to meet the needs of many installations. These can be changed by the installer to suit specific needs if desired. In addition, four sets of pre-programmed communication default values can also be loaded by the installer, each set designed for a specific communication format. These too can be changed to suit the needs of a particular installation.

Changes to these pre-programmed values can be programmed directly from the console (Alpha consoles only) or from an IBM compatible computer terminal either remotely (using a HAYES 1200 SMARTMODEM or a HAYES brand Optima 24 PLUS FAX 96 modem), or at the office or job site (using the 4100SM Serial Module – see DIRECT WIRE DOWNLOADING section). Both methods use the 4130PC Downloading software (be sure that the software version used includes a 4120XM menu selection). *See the DOWNLOADING PRIMER section (Section 9) for more information.*

For alpha consoles, English Language descriptions of the zones and a custom installer message (which appears when the system is ready to arm) can be programmed using the built-in vocabulary of words (see PROGRAMMING ZONE DESCRIPTIONS paragraphs later in this section).

Default Programming

There are five sets of pre-programmed defaults available (one standard, plus four different communication defaults). Any one of these can be loaded into the system's memory. Refer to the COMMUNICATION DEFAULT PROGRAMMING section for instructions.

Data Programming

The programming fields are grouped into two sets of addresses. The first set is accessed as soon as programming mode is entered. To access the second set of addresses (indicated on the programming form by a "1" in front of the 2-digit field address), press *94 while in programming mode, then press [*] plus the first field number desired. Note that the alpha consoles display the words ALT PROGRAM MODE, and the Fixed-word consoles display the word CHECK to indicate the second set of addresses. To return to the first set of addresses, press *99, then press [*] plus the field number desired.

To program specific data fields, press [*] plus the 2-digit field address, then make the required entry. The console will beep when a field has been completely programmed and will automatically display the next field in numerical order. If the number of digits that you enter in the data field is less than the maximum permitted (for example, phone number), the console displays the last entry and waits. To proceed, the next data field address to be programmed must be entered manually (for example, press *05).

To view the contents of a data field, press [#] plus the 2-digit field address. The field's entries will be displayed, but no changes to these entries can be made.

In case of errors: If an address is improperly entered, the console will display FC . If a program entry is improperly entered (for example, a larger number than that which is permitted), the console display will go blank. In either case, simply re-enter the correct number.

To exit programming mode, press either *98 or *99. Use *98 to prevent re-access to programming mode by installer code method. *99 allows installer code access to programming mode.

(Continued from page 38)

Programming Steps

1. Enter Programming mode

Programming mode can be entered in one of two ways.

- Press both the [*] and [#] keys at the same time within 30 seconds after power is applied to the Control. **OR**
- Key the installer code, followed by depression of CODE [8] + 0 + 0 keys. The factory installer code can be changed once in the program mode.

Immediately following entry into the program mode, the following will be displayed on an Alpha console:

Program Mode
*** Fill # View - 00**

Fixed-word consoles will display: **00**

Following the above display, the system is ready to be programmed for the communication format parameters, or accept data entries. To begin data entries, press [*] plus the first field number desired.

2. Set Standard Defaults

Once the Programming mode is entered, clear the system's memory by pressing *97. This ensures all program fields are set to their factory set, pre-programmed values. If desired, load one of the communication default programming sets by entering one of the following code sequences:

TABLE OF DEFAULT PROGRAMMING COMMANDS

PRESS	TO LOAD THIS DEFAULT SET
*97	Loads standard default values for the panel
*94 *80	Low Speed communication defaults
*94 *81	Ademco Express communication defaults
*94 *82	Ademco High Speed communication defaults
*94 *83	Contact ID communication defaults

Refer to the PROGRAMMING COMMUNICATION DEFAULTS section for further instructions if one of the four communication default programming sets is used.

3. Program the data fields

Program the appropriate phone numbers and account numbers, as well as any other programming fields required to customize the system to the needs of the installation. Refer to the PROGRAMMING FORM at the end of this manual.

4. Enter Zone Descriptions (Alpha consoles only)

Refer to the PROGRAMMING ZONE DESCRIPTIONS section to enter zone descriptors and a custom installer's message.

5. Exit Programming Mode

When all fields have been entered and checked, and zone descriptors have been assigned, exit programming mode by pressing either *98 or *99. A second entry of *99 is required if the exit is being done from fields 1*00 and above. To prevent re-access to Programming mode using the Installer's code, use *98. The only way to re-access Programming mode is by depressing both the [*] and [#] keys at the same time within 30 seconds of power up.

Exiting by using *99 always allows reentry into Programming mode using the Installer's code. Either way of exiting will allow access via downloading.

Communication Default Programming

General To help expedite the installation, Ademco has incorporated 4 different communication defaults in the Control (Low Speed, Ademco Express, Ademco High Speed & Ademco's new Contact ID). These defaults automatically program industry-standard code assignments for zones, keypad panics, non-alarm and supervisory conditions, and can be loaded at any time without affecting non-communication program fields.

Using these defaults saves programming time! After loading one of the communication defaults, you only need to wire the devices to their appropriate zones, and program the following:

- Central station phone number(s), fields *33 & *34
- Subscriber's account number(s), fields *32 & *90
- Zone type responses, fields *02-*05 & 1*01-1*05
- Delays, timeouts, and miscellaneous control options.

The system is then operational.

The program fields that are affected by loading one of the communication defaults are fields *45 - *82. Default values for each communication default are listed on the pages at the end of this manual.

For detailed information about reporting formats, see the SYSTEM COMMUNICATION section.

Easy-To-Program Communication Fields

The VISTA XM programming scheme eliminates the need to program zones to channels, and then channels to codes. If programming communication fields manually, simply enter whatever code (3+1, 4+1, 4+2 or Ademco Express) is to be sent for each zone (including panics, non-alarm codes and supervisory codes). NOTE: Enter "10" to transmit an "A", which appears as "0" at the receiver.

All zones are separated into groups of 8, with common restore, trouble and bypass codes for every 2 groups (16 zones). There are 2 double-digit entries for each code.

For 3+1, 4+1, 4+2 and Ademco Express, the first entry is the alarm code for a standard report and also assigns the reporting channel. The second entry is the ID digit for an expanded 3+1 or 4+1 report, or for a 4+2 or Ademco Express report. If the second digit is 0, only 3+1 or 4+1 (or 4+1 express) non-expanded messages will be sent. If only three digits are entered in the account number field, the ID or second digits are ignored, if entered.

For Ademco High Speed format, the first digit entry is the channel assignment for that zone, and the second digit is ignored, if entered.

For Contact ID reporting, the first digit entry (any non zero entry) enables reporting for that zone and also assigns the reporting channel, and the second digit is ignored.

Note: Restoral reports for an event **will not** be sent if the event itself is not enabled, even if a restore code is programmed for that event.

Low Speed (*94 *80)

Loading this default does the following:

- Selects low speed, standard format with no checksum, for both phone numbers.
- Assigns the following report codes:
 - 03 for zones 2-47
 - 01 for zones 1 & 48-55 (fire zones)
 - 02 for zones 62,63 (panic transmitters), & 95, 96,99 (keypad panics)
 - 09 for all alarm restores
- Enables all zone type restores.

Ademco Express
(*94 *81)

Loading this default does the following:

- Selects Ademco express reporting format, with checksum, for both phone numbers.
- Report codes for zones 1-64, 4281s and keypad panics are sent as their respective zone ID numbers (01-64, 88-91, 95-99), Duress is sent as "DD". Alarm restore is "E" + second digit.
- Enables all zone type restores.

Ademco High Speed
(*94 *82)

Loading this default does the following:

- Selects Ademco High Speed format, with no checksum, for both phone numbers.
- Reporting is assigned to the following channels:
 - Channel 1 for zones 1 & zones 48-55 (Fire zones)
 - Channel 2 for zones 2-8
 - Channel 3 for zones 9-16
 - Channel 4 for zones 17-31
 - Channel 5 for zones 32-47 (RF interior zones)
 - Channel 6 for zones 56-61 & 64
 - Channel 9 for zones 62 & 63 (panic transmitter)
 - Channel 7 for second 4281 (88 & 89)
 - Channel 8 for first 4281 (90 & 91)
 - Channels 10, 11 & 12 for keypad panics 95, 96 & 99 respectively
- Enables all zone type restores.
- Enables Duress to be sent.

Contact ID
(*94 *83)

Loading this default does the following:

- Selects Contact ID format for both phone numbers.
- Reporting is enabled for all zones.
- Enables all zone type restores.
- Refer to the SYSTEM COMMUNICATION section for event code definitions.

COMMUNICATION DEFAULTS for LOW SPEED FORMAT (*94-80)

- | | |
|---|---|
| <p>*45 PRIMARY FORMAT <input type="checkbox"/> Ademco Low Speed</p> <p>*46 LOW SPEED FORMAT (Primary) <input type="checkbox"/> Ademco Low Speed</p> <p>*47 SECONDARY FORMAT <input type="checkbox"/> Ademco Low Speed</p> <p>*48 LOW SPEED FORMAT (Sec.) <input type="checkbox"/> Ademco Low Speed</p> <p>*49 CHECKSUM VERIFICATION <input type="checkbox"/> <input type="checkbox"/>
 <small>No checksum Primary Secondary</small></p> <p>*50 SESCOA/RADIONICS SELECT <input type="checkbox"/> Radionics</p> | <p>*51 DUAL REPORTING <input type="checkbox"/> no</p> <p>*52 STANDARD/EXPANDED REPORT FOR PRIMARY
 <input type="checkbox"/> <input type="checkbox"/> <input type="checkbox"/> <input type="checkbox"/> <input type="checkbox"/> <input type="checkbox"/> standard
 <small>Alarm Rstr Bypass Trbl Opr/Cls Low Bat</small></p> <p>*53 STANDARD/EXPANDED REPORT FOR SECONDARY
 <input type="checkbox"/> <input type="checkbox"/> <input type="checkbox"/> <input type="checkbox"/> <input type="checkbox"/> <input type="checkbox"/> standard
 <small>Alarm Rstr Bypass Trbl Opr/Cls Low Bat</small></p> |
|---|---|

ALARM REPORT CODE & ID DIGITS FOR ZONES 1-32 & SUPERVISORY & RESTORE CODES

*54 CODE	*55 ID	*56 CODE	*57 ID	*58	*59 CODE	*60 ID	*61 CODE	*62 ID	*63	
1	<input type="checkbox"/> 011	<input type="checkbox"/> 010	9	<input type="checkbox"/> 013 <input type="checkbox"/> 010	<input type="checkbox"/> 019 Alarm Rst.	17	<input type="checkbox"/> 013 <input type="checkbox"/> 010	25	<input type="checkbox"/> 013 <input type="checkbox"/> 010	<input type="checkbox"/> 019 Alarm Rst.
2	<input type="checkbox"/> 013	<input type="checkbox"/> 010	10	<input type="checkbox"/> 013 <input type="checkbox"/> 010	<input type="checkbox"/> 010 Trouble	18	<input type="checkbox"/> 013 <input type="checkbox"/> 010	26	<input type="checkbox"/> 013 <input type="checkbox"/> 010	<input type="checkbox"/> 010 Trouble
3	<input type="checkbox"/> 013	<input type="checkbox"/> 010	11	<input type="checkbox"/> 013 <input type="checkbox"/> 010	<input type="checkbox"/> 010 Trble Rst.	19	<input type="checkbox"/> 013 <input type="checkbox"/> 010	27	<input type="checkbox"/> 013 <input type="checkbox"/> 010	<input type="checkbox"/> 010 Trble Rst.
4	<input type="checkbox"/> 013	<input type="checkbox"/> 010	12	<input type="checkbox"/> 013 <input type="checkbox"/> 010	<input type="checkbox"/> 010 Bypass	20	<input type="checkbox"/> 013 <input type="checkbox"/> 010	28	<input type="checkbox"/> 013 <input type="checkbox"/> 010	<input type="checkbox"/> 010 Bypass
5	<input type="checkbox"/> 013	<input type="checkbox"/> 010	13	<input type="checkbox"/> 013 <input type="checkbox"/> 010	<input type="checkbox"/> 010 Bypss Rst.	21	<input type="checkbox"/> 013 <input type="checkbox"/> 010	29	<input type="checkbox"/> 013 <input type="checkbox"/> 010	<input type="checkbox"/> 010 Bypss Rst.
6	<input type="checkbox"/> 013	<input type="checkbox"/> 010	14	<input type="checkbox"/> 013 <input type="checkbox"/> 010		22	<input type="checkbox"/> 013 <input type="checkbox"/> 010	30	<input type="checkbox"/> 013 <input type="checkbox"/> 010	
7	<input type="checkbox"/> 013	<input type="checkbox"/> 010	15	<input type="checkbox"/> 013 <input type="checkbox"/> 010		23	<input type="checkbox"/> 013 <input type="checkbox"/> 010	31	<input type="checkbox"/> 013 <input type="checkbox"/> 010	
8	<input type="checkbox"/> 013	<input type="checkbox"/> 010	16	<input type="checkbox"/> 013 <input type="checkbox"/> 010		24	<input type="checkbox"/> 013 <input type="checkbox"/> 010	32	<input type="checkbox"/> 013 <input type="checkbox"/> 010	

ALARM REPORT CODE & ID DIGITS FOR ZONES 33-64 & SUPERVISORY & RESTORE CODES

*64 CODE	*65 ID	*66 CODE	*67 ID	*68	*69 CODE	*70 ID	*71 CODE	*72 ID	*73	
33	<input type="checkbox"/> 013	<input type="checkbox"/> 010	41	<input type="checkbox"/> 013 <input type="checkbox"/> 010	<input type="checkbox"/> 019 Alarm Rst.	49	<input type="checkbox"/> 011 <input type="checkbox"/> 010	57	<input type="checkbox"/> 013 <input type="checkbox"/> 010	<input type="checkbox"/> 019 Alarm Rst.
34	<input type="checkbox"/> 013	<input type="checkbox"/> 010	42	<input type="checkbox"/> 013 <input type="checkbox"/> 010	<input type="checkbox"/> 010 Trouble	50	<input type="checkbox"/> 011 <input type="checkbox"/> 010	58	<input type="checkbox"/> 013 <input type="checkbox"/> 010	<input type="checkbox"/> 010 Trouble
35	<input type="checkbox"/> 013	<input type="checkbox"/> 010	43	<input type="checkbox"/> 013 <input type="checkbox"/> 010	<input type="checkbox"/> 010 Trble Rst.	51	<input type="checkbox"/> 011 <input type="checkbox"/> 010	59	<input type="checkbox"/> 013 <input type="checkbox"/> 010	<input type="checkbox"/> 010 Trble Rst.
36	<input type="checkbox"/> 013	<input type="checkbox"/> 010	44	<input type="checkbox"/> 013 <input type="checkbox"/> 010	<input type="checkbox"/> 010 Bypass	52	<input type="checkbox"/> 011 <input type="checkbox"/> 010	60	<input type="checkbox"/> 013 <input type="checkbox"/> 010	<input type="checkbox"/> 010 Bypass
37	<input type="checkbox"/> 013	<input type="checkbox"/> 010	45	<input type="checkbox"/> 013 <input type="checkbox"/> 010	<input type="checkbox"/> 010 Bypss Rst.	53	<input type="checkbox"/> 011 <input type="checkbox"/> 010	61	<input type="checkbox"/> 013 <input type="checkbox"/> 010	<input type="checkbox"/> 010 Bypss Rst.
38	<input type="checkbox"/> 013	<input type="checkbox"/> 010	46	<input type="checkbox"/> 013 <input type="checkbox"/> 010		54	<input type="checkbox"/> 011 <input type="checkbox"/> 010	62	<input type="checkbox"/> 012 <input type="checkbox"/> 010	
39	<input type="checkbox"/> 013	<input type="checkbox"/> 010	47	<input type="checkbox"/> 013 <input type="checkbox"/> 010		55	<input type="checkbox"/> 011 <input type="checkbox"/> 010	63	<input type="checkbox"/> 012 <input type="checkbox"/> 010	
40	<input type="checkbox"/> 013	<input type="checkbox"/> 010	48	<input type="checkbox"/> 011 <input type="checkbox"/> 010		56	<input type="checkbox"/> 013 <input type="checkbox"/> 010	64	<input type="checkbox"/> 013 <input type="checkbox"/> 010	

ALARM REPORT CODE & ID DIGITS FOR RF RCVRs & PANICS, & THEIR SUPV. & RESTORE CODES

*74 CODE	*75 ID	*76 CODE	*77 ID	*78
81	<input type="checkbox"/> 017	<input type="checkbox"/> 010	89	<input type="checkbox"/> 017 <input type="checkbox"/> 010 <input type="checkbox"/> 019 Alarm Rst.
NU	<input type="checkbox"/> 010	<input type="checkbox"/> 010	90	<input type="checkbox"/> 017 <input type="checkbox"/> 010 <input type="checkbox"/> 010 Trouble
83	<input type="checkbox"/> 017	<input type="checkbox"/> 010	91	<input type="checkbox"/> 017 <input type="checkbox"/> 010 <input type="checkbox"/> 010 Trble Rst.
NU	<input type="checkbox"/> 010	<input type="checkbox"/> 010	Dures	<input type="checkbox"/> 012 <input type="checkbox"/> 010 <input type="checkbox"/> 010 Bypass
NU	<input type="checkbox"/> 010	<input type="checkbox"/> 010		<input type="checkbox"/> 010 <input type="checkbox"/> 010 <input type="checkbox"/> 010 Bypss Rst.
NU	<input type="checkbox"/> 010	<input type="checkbox"/> 010	95	<input type="checkbox"/> 012 <input type="checkbox"/> 010 (1 + #/A)
NU	<input type="checkbox"/> 010	<input type="checkbox"/> 010	96	<input type="checkbox"/> 012 <input type="checkbox"/> 010 (3 + #/C)
88	<input type="checkbox"/> 017	<input type="checkbox"/> 010	99	<input type="checkbox"/> 012 <input type="checkbox"/> 010 (* + #/B)

NOTES: 88 & 90 = RCVR not receiving transmitter signals. 89 & 91 = RCVR not responding, bad conn. to panel.
 81=4219 supervision; 83= 4219 tamper;

SYSTEM NON ALARM CODES		
	*81 First Digit	*82 Second Digit
Close	<input type="checkbox"/> 010	<input type="checkbox"/> 010
Open	<input type="checkbox"/> 010	<input type="checkbox"/> 010
Low Battery	<input type="checkbox"/> 010	<input type="checkbox"/> 010
Low Bat Res.	<input type="checkbox"/> 010	<input type="checkbox"/> 010
AC Loss	<input type="checkbox"/> 010	<input type="checkbox"/> 010
AC Restore	<input type="checkbox"/> 010	<input type="checkbox"/> 010
Test	<input type="checkbox"/> 010	<input type="checkbox"/> 010
Power	<input type="checkbox"/> 010	<input type="checkbox"/> 010
Cancel	<input type="checkbox"/> 010	<input type="checkbox"/> 010
Prog. Tamper	<input type="checkbox"/> 010	<input type="checkbox"/> 010

Second digit of each code applies only to 4+2 or expanded (fields *52 & *53) formats.

ZONE TYPE RESTORE ENABLES

- *79 ZONE TYPES 1-8. All enabled**
- | | | | | | | | |
|----------------------------|----------------------------|----------------------------|----------------------------|----------------------------|----------------------------|----------------------------|----------------------------|
| <input type="checkbox"/> 1 | <input type="checkbox"/> 2 | <input type="checkbox"/> 3 | <input type="checkbox"/> 4 | <input type="checkbox"/> 5 | <input type="checkbox"/> 6 | <input type="checkbox"/> 7 | <input type="checkbox"/> 8 |
| 1 | 2 | 3 | 4 | 5 | 6 | 7 | 8 |

- *80 ZONE TYPES 9 & 10. All enabled**
- | | |
|----------------------------|-----------------------------|
| <input type="checkbox"/> 9 | <input type="checkbox"/> 10 |
| 9 | 10 |

COMMUNICATION DEFAULTS for ADEMCO EXPRESS FORMAT (-94-81)

<p>*45 PRIMARY FORMAT <input type="text" value="3"/> Ademco Express</p> <p>*46 LOW SPEED FORMAT (Primary) <input type="text" value="0"/></p> <p>*47 SECONDARY FORMAT <input type="text" value="3"/> Ademco Express</p> <p>*48 LOW SPEED FORMAT (Sec.) <input type="text" value="0"/></p> <p>*49 CHECKSUM VERIFICATION <input type="text" value="0"/> <input type="text" value="0"/> No checksum Primary Secondary</p> <p>*50 SESCOA/RADIONICS SELECT <input type="text" value="0"/> Radionics</p>	<p>*51 DUAL REPORTING <input type="text" value="0"/> no</p> <p>*52 STANDARD/EXPANDED REPORT FOR PRIMARY <input type="text" value="0"/> <input type="text" value="0"/> <input type="text" value="0"/> <input type="text" value="0"/> <input type="text" value="0"/> <input type="text" value="0"/> standard Alarm Rstr Bypass Trbl Oprn/Cls Low Bat</p> <p>*53 STANDARD/EXPANDED REPORT FOR SECONDARY <input type="text" value="0"/> <input type="text" value="0"/> <input type="text" value="0"/> <input type="text" value="0"/> <input type="text" value="0"/> <input type="text" value="0"/> standard Alarm Rstr Bypass Trbl Oprn/Cls Low Bat</p>
---	--

ALARM REPORT CODE & ID DIGITS FOR ZONES 1-32 & SUPERVISORY & RESTORE CODES

*54 CODE	*55 ID	*56 CODE	*57 ID	*58	*59 CODE	*60 ID	*61 CODE	*62 ID	*63				
1	<input type="text" value="110"/>	<input type="text" value="011"/>	9	<input type="text" value="110"/>	<input type="text" value="019"/>	<input type="text" value="114"/> Alarm Rst.	17	<input type="text" value="011"/>	<input type="text" value="017"/>	25	<input type="text" value="012"/>	<input type="text" value="015"/>	<input type="text" value="114"/> Alarm Rst.
2	<input type="text" value="110"/>	<input type="text" value="012"/>	10	<input type="text" value="011"/>	<input type="text" value="110"/>	<input type="text" value="010"/> Trouble	18	<input type="text" value="011"/>	<input type="text" value="018"/>	26	<input type="text" value="012"/>	<input type="text" value="016"/>	<input type="text" value="010"/> Trouble
3	<input type="text" value="110"/>	<input type="text" value="013"/>	11	<input type="text" value="011"/>	<input type="text" value="011"/>	<input type="text" value="010"/> Trble Rst.	19	<input type="text" value="011"/>	<input type="text" value="019"/>	27	<input type="text" value="012"/>	<input type="text" value="017"/>	<input type="text" value="010"/> Trble Rst.
4	<input type="text" value="110"/>	<input type="text" value="014"/>	12	<input type="text" value="011"/>	<input type="text" value="012"/>	<input type="text" value="010"/> Bypass	20	<input type="text" value="012"/>	<input type="text" value="110"/>	28	<input type="text" value="012"/>	<input type="text" value="018"/>	<input type="text" value="010"/> Bypass
5	<input type="text" value="110"/>	<input type="text" value="015"/>	13	<input type="text" value="011"/>	<input type="text" value="013"/>	<input type="text" value="010"/> Bypss Rst.	21	<input type="text" value="012"/>	<input type="text" value="011"/>	29	<input type="text" value="012"/>	<input type="text" value="019"/>	<input type="text" value="010"/> Bypss Rst.
6	<input type="text" value="110"/>	<input type="text" value="016"/>	14	<input type="text" value="011"/>	<input type="text" value="014"/>		22	<input type="text" value="012"/>	<input type="text" value="012"/>	30	<input type="text" value="013"/>	<input type="text" value="110"/>	
7	<input type="text" value="110"/>	<input type="text" value="017"/>	15	<input type="text" value="011"/>	<input type="text" value="015"/>		23	<input type="text" value="012"/>	<input type="text" value="013"/>	31	<input type="text" value="013"/>	<input type="text" value="011"/>	
8	<input type="text" value="110"/>	<input type="text" value="018"/>	16	<input type="text" value="011"/>	<input type="text" value="016"/>		24	<input type="text" value="012"/>	<input type="text" value="014"/>	32	<input type="text" value="013"/>	<input type="text" value="012"/>	

ALARM REPORT CODE & ID DIGITS FOR ZONES 33-64 & SUPERVISORY & RESTORE CODES

*64 CODE	*65 ID	*66 CODE	*67 ID	*68	*69 CODE	*70 ID	*71 CODE	*72 ID	*73				
33	<input type="text" value="013"/>	<input type="text" value="013"/>	41	<input type="text" value="014"/>	<input type="text" value="011"/>	<input type="text" value="114"/> Alarm Rst.	49	<input type="text" value="014"/>	<input type="text" value="019"/>	57	<input type="text" value="015"/>	<input type="text" value="017"/>	<input type="text" value="114"/> Alarm Rst.
34	<input type="text" value="013"/>	<input type="text" value="014"/>	42	<input type="text" value="014"/>	<input type="text" value="012"/>	<input type="text" value="010"/> Trouble	50	<input type="text" value="015"/>	<input type="text" value="110"/>	58	<input type="text" value="015"/>	<input type="text" value="018"/>	<input type="text" value="010"/> Trouble
35	<input type="text" value="013"/>	<input type="text" value="015"/>	43	<input type="text" value="014"/>	<input type="text" value="013"/>	<input type="text" value="010"/> Trble Rst.	51	<input type="text" value="015"/>	<input type="text" value="011"/>	59	<input type="text" value="015"/>	<input type="text" value="019"/>	<input type="text" value="010"/> Trble Rst.
36	<input type="text" value="013"/>	<input type="text" value="016"/>	44	<input type="text" value="014"/>	<input type="text" value="014"/>	<input type="text" value="010"/> Bypass	52	<input type="text" value="015"/>	<input type="text" value="012"/>	60	<input type="text" value="016"/>	<input type="text" value="110"/>	<input type="text" value="010"/> Bypass
37	<input type="text" value="013"/>	<input type="text" value="017"/>	45	<input type="text" value="014"/>	<input type="text" value="015"/>	<input type="text" value="010"/> Bypss Rst.	53	<input type="text" value="015"/>	<input type="text" value="013"/>	61	<input type="text" value="016"/>	<input type="text" value="011"/>	<input type="text" value="010"/> Bypss Rst.
38	<input type="text" value="013"/>	<input type="text" value="018"/>	46	<input type="text" value="014"/>	<input type="text" value="016"/>		54	<input type="text" value="015"/>	<input type="text" value="014"/>	62	<input type="text" value="016"/>	<input type="text" value="012"/>	
39	<input type="text" value="013"/>	<input type="text" value="019"/>	47	<input type="text" value="014"/>	<input type="text" value="017"/>		55	<input type="text" value="015"/>	<input type="text" value="015"/>	63	<input type="text" value="016"/>	<input type="text" value="013"/>	
40	<input type="text" value="014"/>	<input type="text" value="110"/>	48	<input type="text" value="014"/>	<input type="text" value="018"/>		56	<input type="text" value="015"/>	<input type="text" value="016"/>	64	<input type="text" value="016"/>	<input type="text" value="014"/>	

ALARM REPORT CODE & ID DIGITS FOR RF RCVRs & PANICS, & THEIR SUPV. & RESTORE CODES

*74 CODE	*75 ID	*76 CODE	*77 ID	*78		
81	<input type="text" value="018"/>	<input type="text" value="011"/>	89	<input type="text" value="018"/>	<input type="text" value="019"/>	<input type="text" value="114"/> Alarm Rst.
NU	<input type="text" value="010"/>	<input type="text" value="010"/>	90	<input type="text" value="019"/>	<input type="text" value="110"/>	<input type="text" value="010"/> Trouble
83	<input type="text" value="018"/>	<input type="text" value="013"/>	91	<input type="text" value="019"/>	<input type="text" value="011"/>	<input type="text" value="010"/> Trble Rst.
NU	<input type="text" value="010"/>	<input type="text" value="010"/>	Dures	<input type="text" value="113"/>	<input type="text" value="113"/>	<input type="text" value="010"/> Bypass
NU	<input type="text" value="010"/>	<input type="text" value="010"/>		<input type="text" value="010"/>	<input type="text" value="010"/>	<input type="text" value="010"/> Bypss Rst.
NU	<input type="text" value="010"/>	<input type="text" value="010"/>	95	<input type="text" value="019"/>	<input type="text" value="015"/>	(1 + #A)
NU	<input type="text" value="010"/>	<input type="text" value="010"/>	96	<input type="text" value="019"/>	<input type="text" value="016"/>	(3 + #/C)
88	<input type="text" value="018"/>	<input type="text" value="018"/>	99	<input type="text" value="019"/>	<input type="text" value="019"/>	(* + #)/B

SYSTEM NON ALARM CODES		
	*81 First Digit	*82 Second Digit
Close	<input type="text" value="010"/>	<input type="text" value="010"/>
Open	<input type="text" value="010"/>	<input type="text" value="010"/>
Low Battery	<input type="text" value="010"/>	<input type="text" value="010"/>
Low Bat Res.	<input type="text" value="010"/>	<input type="text" value="010"/>
AC Loss	<input type="text" value="010"/>	<input type="text" value="010"/>
AC Restore	<input type="text" value="010"/>	<input type="text" value="010"/>
Test	<input type="text" value="010"/>	<input type="text" value="010"/>
Power	<input type="text" value="010"/>	<input type="text" value="010"/>
Cancel	<input type="text" value="010"/>	<input type="text" value="010"/>
Prog. Tamper	<input type="text" value="010"/>	<input type="text" value="010"/>

Second digit of each code applies only to 4+2 or expanded (fields *52 & *53) formats.

NOTES: 88 & 90 = RCVR not receiving transmitter signals. 89 & 91 = RCVR not responding, bad conn. to panel.
 81=4219 supervision; 83= 4219 tamper;

ZONE TYPE RESTORE ENABLES

*79 ZONE TYPES 1-8. All enabled

<input type="text" value="1"/>	<input type="text" value="1"/>	<input type="text" value="1"/>	<input type="text" value="1"/>	<input type="text" value="1"/>	<input type="text" value="1"/>	<input type="text" value="1"/>	<input type="text" value="1"/>
1	2	3	4	5	6	7	8

*80 ZONE TYPES 9 & 10. All enabled

<input type="text" value="1"/>	<input type="text" value="1"/>
9	10

COMMUNICATION DEFAULTS for ADEMCO HIGH SPEED FORMAT (*94-82)

*45 PRIMARY FORMAT	<input type="text" value="2"/>	Ademco High Speed	*51 DUAL REPORTING	<input type="text" value="0"/>	no					
*46 LOW SPEED FORMAT (Primary)	<input type="text" value="0"/>		*52 STANDARD/EXPANDED REPORT FOR PRIMARY	<input type="text" value="0"/>	<input type="text" value="0"/>	<input type="text" value="0"/>	<input type="text" value="0"/>	<input type="text" value="0"/>	<input type="text" value="0"/>	standard
*47 SECONDARY FORMAT	<input type="text" value="2"/>	Ademco High Speed		Alarm	Rstr	Bypass	Trbl	Oprv/Cls	Low Bat	
*48 LOW SPEED FORMAT (Sec.)	<input type="text" value="0"/>		*53 STANDARD/EXPANDED REPORT FOR SECONDARY	<input type="text" value="0"/>	<input type="text" value="0"/>	<input type="text" value="0"/>	<input type="text" value="0"/>	<input type="text" value="0"/>	<input type="text" value="0"/>	standard
*49 CHECKSUM VERIFICATION	<input type="text" value="0"/>	<input type="text" value="0"/>		Alarm	Rstr	Bypass	Trbl	Oprv/Cls	Low Bat	
No checksum		Primary Secondary								
*50 SESCOA/RADIONICS SELECT	<input type="text" value="0"/>	Radionics								

ALARM REPORT CODE & ID DIGITS FOR ZONES 1-32 & SUPERVISORY & RESTORE CODES

*54 CODE	*55 ID	*56 CODE	*57 ID	*58	*59 CODE	*60 ID	*61 CODE	*62 ID	*63						
1	<input type="text" value="011"/>	<input type="text" value="010"/>	9	<input type="text" value="013"/>	<input type="text" value="010"/>	011	Alarm Rst.	17	<input type="text" value="014"/>	<input type="text" value="010"/>	25	<input type="text" value="014"/>	<input type="text" value="010"/>	011	Alarm Rst.
2	<input type="text" value="012"/>	<input type="text" value="010"/>	10	<input type="text" value="013"/>	<input type="text" value="010"/>	010	Trouble	18	<input type="text" value="014"/>	<input type="text" value="010"/>	26	<input type="text" value="014"/>	<input type="text" value="010"/>	010	Trouble
3	<input type="text" value="012"/>	<input type="text" value="010"/>	11	<input type="text" value="013"/>	<input type="text" value="010"/>	010	Trble Rst.	19	<input type="text" value="014"/>	<input type="text" value="010"/>	27	<input type="text" value="014"/>	<input type="text" value="010"/>	010	Trble Rst.
4	<input type="text" value="012"/>	<input type="text" value="010"/>	12	<input type="text" value="013"/>	<input type="text" value="010"/>	010	Bypass	20	<input type="text" value="014"/>	<input type="text" value="010"/>	28	<input type="text" value="014"/>	<input type="text" value="010"/>	010	Bypass
5	<input type="text" value="012"/>	<input type="text" value="010"/>	13	<input type="text" value="013"/>	<input type="text" value="010"/>	010	Bypass Rst.	21	<input type="text" value="014"/>	<input type="text" value="010"/>	29	<input type="text" value="014"/>	<input type="text" value="010"/>	010	Bypass Rst.
6	<input type="text" value="012"/>	<input type="text" value="010"/>	14	<input type="text" value="013"/>	<input type="text" value="010"/>			22	<input type="text" value="014"/>	<input type="text" value="010"/>	30	<input type="text" value="014"/>	<input type="text" value="010"/>		
7	<input type="text" value="012"/>	<input type="text" value="010"/>	15	<input type="text" value="013"/>	<input type="text" value="010"/>			23	<input type="text" value="014"/>	<input type="text" value="010"/>	31	<input type="text" value="014"/>	<input type="text" value="010"/>		
8	<input type="text" value="012"/>	<input type="text" value="010"/>	16	<input type="text" value="013"/>	<input type="text" value="010"/>			24	<input type="text" value="014"/>	<input type="text" value="010"/>	32	<input type="text" value="015"/>	<input type="text" value="010"/>		

ALARM REPORT CODE & ID DIGITS FOR ZONES 33-64 & SUPERVISORY & RESTORE CODES

*64 CODE	*65 ID	*66 CODE	*67 ID	*68	*69 CODE	*70 ID	*71 CODE	*72 ID	*73						
33	<input type="text" value="015"/>	<input type="text" value="010"/>	41	<input type="text" value="015"/>	<input type="text" value="010"/>	011	Alarm Rst.	49	<input type="text" value="011"/>	<input type="text" value="010"/>	57	<input type="text" value="016"/>	<input type="text" value="010"/>	011	Alarm Rst.
34	<input type="text" value="015"/>	<input type="text" value="010"/>	42	<input type="text" value="015"/>	<input type="text" value="010"/>	010	Trouble	50	<input type="text" value="011"/>	<input type="text" value="010"/>	58	<input type="text" value="016"/>	<input type="text" value="010"/>	010	Trouble
35	<input type="text" value="015"/>	<input type="text" value="010"/>	43	<input type="text" value="015"/>	<input type="text" value="010"/>	010	Trble Rst.	51	<input type="text" value="011"/>	<input type="text" value="010"/>	59	<input type="text" value="016"/>	<input type="text" value="010"/>	010	Trble Rst.
36	<input type="text" value="015"/>	<input type="text" value="010"/>	44	<input type="text" value="015"/>	<input type="text" value="010"/>	010	Bypass	52	<input type="text" value="011"/>	<input type="text" value="010"/>	60	<input type="text" value="016"/>	<input type="text" value="010"/>	010	Bypass
37	<input type="text" value="015"/>	<input type="text" value="010"/>	45	<input type="text" value="015"/>	<input type="text" value="010"/>	010	Bypass Rst.	53	<input type="text" value="011"/>	<input type="text" value="010"/>	61	<input type="text" value="016"/>	<input type="text" value="010"/>	010	Bypass Rst.
38	<input type="text" value="015"/>	<input type="text" value="010"/>	46	<input type="text" value="015"/>	<input type="text" value="010"/>			54	<input type="text" value="011"/>	<input type="text" value="010"/>	62	<input type="text" value="019"/>	<input type="text" value="010"/>		
39	<input type="text" value="015"/>	<input type="text" value="010"/>	47	<input type="text" value="015"/>	<input type="text" value="010"/>			55	<input type="text" value="011"/>	<input type="text" value="010"/>	63	<input type="text" value="019"/>	<input type="text" value="010"/>		
40	<input type="text" value="015"/>	<input type="text" value="010"/>	48	<input type="text" value="011"/>	<input type="text" value="010"/>			56	<input type="text" value="016"/>	<input type="text" value="010"/>	64	<input type="text" value="016"/>	<input type="text" value="010"/>		

ALARM REPORT CODE & ID DIGITS FOR RF RCVRs & PANICS, & THEIR SUPV. & RESTORE CODES

*74 CODE	*75 ID	*76 CODE	*77 ID	*78			
81	<input type="text" value="017"/>	<input type="text" value="010"/>	89	<input type="text" value="017"/>	<input type="text" value="010"/>	011	Alarm Rst.
NU	<input type="text" value="010"/>	<input type="text" value="010"/>	90	<input type="text" value="018"/>	<input type="text" value="010"/>	010	Trouble
83	<input type="text" value="017"/>	<input type="text" value="010"/>	91	<input type="text" value="018"/>	<input type="text" value="010"/>	010	Trble Rst.
NU	<input type="text" value="010"/>	<input type="text" value="010"/>	Dures	<input type="text" value="011"/>	<input type="text" value="010"/>	010	Bypass
NU	<input type="text" value="010"/>	<input type="text" value="010"/>		<input type="text" value="010"/>	<input type="text" value="010"/>	010	Bypass Rst.
NU	<input type="text" value="010"/>	<input type="text" value="010"/>	95	<input type="text" value="110"/>	<input type="text" value="010"/>	(1 + */A)	
NU	<input type="text" value="010"/>	<input type="text" value="010"/>	96	<input type="text" value="111"/>	<input type="text" value="010"/>	(3 + #/C)	
88	<input type="text" value="017"/>	<input type="text" value="010"/>	99	<input type="text" value="112"/>	<input type="text" value="010"/>	(* + #/B)	

NOTES: 88 & 90 = RCVR not receiving transmitter signals. 89 & 91 = RCVR not responding, bad conn. to panel.
81=4219 supervision; 83= 4219 tamper;

SYSTEM NON ALARM CODES		
	*81 First Digit	*82 Second Digit
Close	<input type="text" value="010"/>	<input type="text" value="010"/>
Open	<input type="text" value="010"/>	<input type="text" value="010"/>
Low Battery	<input type="text" value="010"/>	<input type="text" value="010"/>
Low Bat Res.	<input type="text" value="010"/>	<input type="text" value="010"/>
AC Loss	<input type="text" value="010"/>	<input type="text" value="010"/>
AC Restore	<input type="text" value="010"/>	<input type="text" value="010"/>
Test	<input type="text" value="010"/>	<input type="text" value="010"/>
Power	<input type="text" value="010"/>	<input type="text" value="010"/>
Cancel	<input type="text" value="010"/>	<input type="text" value="010"/>
Prog. Tamper	<input type="text" value="010"/>	<input type="text" value="010"/>

Second digit of each code applies only to 4+2 or expanded (fields *52 & *53) formats.

ZONE TYPE RESTORE ENABLES

*79 ZONE TYPES 1-8. All enabled

<input type="text" value="1"/>	<input type="text" value="1"/>	<input type="text" value="1"/>	<input type="text" value="1"/>	<input type="text" value="1"/>	<input type="text" value="1"/>	<input type="text" value="1"/>	<input type="text" value="1"/>
1	2	3	4	5	6	7	8

*80 ZONE TYPES 9 & 10. All enabled

<input type="text" value="1"/>	<input type="text" value="1"/>
9	10

COMMUNICATION DEFAULTS for ADEMCO's CONTACT ID FORMAT (+94+83)

<p>*45 PRIMARY FORMAT <input type="checkbox"/> 1 Ademco Contact ID</p> <p>*46 LOW SPEED FORMAT (Primary) <input type="checkbox"/> 0</p> <p>*47 SECONDARY FORMAT <input type="checkbox"/> 1 Ademco Contact ID</p> <p>*48 LOW SPEED FORMAT (Sec.) <input type="checkbox"/> 0</p> <p>*49 CHECKSUM VERIFICATION <input type="checkbox"/> 0 <input type="checkbox"/> 0 <small>No checksum Primary Secondary</small></p> <p>*50 SESCOA/RADIONICS SELECT <input type="checkbox"/> 0 Radionics</p>	<p>*51 DUAL REPORTING <input type="checkbox"/> 0 no</p> <p>*52 STANDARD/EXPANDED REPORT FOR PRIMARY <input type="checkbox"/> 0 <input type="checkbox"/> 0 <input type="checkbox"/> 0 <input type="checkbox"/> 0 <input type="checkbox"/> 0 <input type="checkbox"/> 0 standard <small>Alarm Rstr Bypass Trbl Opn/Cls Low Bat</small></p> <p>*53 STANDARD/EXPANDED REPORT FOR SECONDARY <input type="checkbox"/> 0 <input type="checkbox"/> 0 <input type="checkbox"/> 0 <input type="checkbox"/> 0 <input type="checkbox"/> 0 standard <small>Alarm Rstr Bypass Trbl Opn/Cls Low Bat</small></p>
---	--

ALARM REPORT CODE & ID DIGITS FOR ZONES 1-32 & SUPERVISORY & RESTORE CODES

*54 CODE	*55 ID	*56 CODE	*57 ID	*58	*59 CODE	*60 ID	*61 CODE	*62 ID	*63			
1	011	010	9 019	010	011	Alarm Rst.	17 012	010	25 110	010	011	Alarm Rst.
2	012	010	10 110	010	010	Trouble	18 013	010	26 111	010	010	Trouble
3	013	010	11 111	010	010	Trble Rst.	19 014	010	27 112	010	010	Trble Rst.
4	014	010	12 112	010	010	Bypass	20 015	010	28 113	010	010	Bypass
5	015	010	13 113	010	010	Bypass Rst.	21 016	010	29 114	010	010	Bypass Rst.
6	016	010	14 114	010			22 017	010	30 115	010		
7	017	010	15 115	010			23 018	010	31 011	010		
8	018	010	16 011	010			24 019	010	32 012	010		

ALARM REPORT CODE & ID DIGITS FOR ZONES 33-64 & SUPERVISORY & RESTORE CODES

*64 CODE	*65 ID	*66 CODE	*67 ID	*68	*69 CODE	*70 ID	*71 CODE	*72 ID	*73			
33	013	010	41 111	010	011	Alarm Rst.	49 014	010	57 112	010	011	Alarm Rst.
34	014	010	42 112	010	010	Trouble	50 015	010	58 113	010	010	Trouble
35	015	010	43 113	010	010	Trble Rst.	51 016	010	59 114	010	010	Trble Rst.
36	016	010	44 114	010	010	Bypass	52 017	010	60 115	010	010	Bypass
37	017	010	45 115	010	010	Bypass Rst.	53 018	010	61 011	010	010	Bypass Rst.
38	018	010	46 011	010			54 019	010	62 012	010		
39	019	010	47 012	010			55 110	010	63 013	010		
40	110	010	48 013	010			56 111	010	64 014	010		

ALARM REPORT CODE & ID DIGITS FOR RF RCVRs & PANICS, & THEIR SUPV. & RESTORE CODES

*74 CODE	*75 ID	*76 CODE	*77 ID	*78		
81	114	010	89 114	010	011	Alarm Rst.
NU	010	010	90 115	010	010	Trouble
83	113	010	91 011	010	010	Trble Rst.
NU	010	010	Dures 012	010	010	Bypass
NU	010	010	010	010	010	Bypass Rst.
NU	010	010	95 014	010	(1 + *A)	
NU	010	010	96 015	010	(3 + #/C)	
88	113	010	99 016	010	(* + #/B)	

NOTES: 88 & 90 = RCVR not receiving transmitter signals. 89 & 91 = RCVR not responding, bad conn. to panel.
 81=4219 supervision; 83= 4219 tamper;

SYSTEM NON ALARM CODES		
	*81 First Digit	*82 Second Digit
Close	<input type="checkbox"/> 010	<input type="checkbox"/> 010
Open	<input type="checkbox"/> 010	<input type="checkbox"/> 010
Low Battery	<input type="checkbox"/> 010	<input type="checkbox"/> 010
Low Bat Res.	<input type="checkbox"/> 010	<input type="checkbox"/> 010
AC Loss	<input type="checkbox"/> 010	<input type="checkbox"/> 010
AC Restore	<input type="checkbox"/> 010	<input type="checkbox"/> 010
Test	<input type="checkbox"/> 010	<input type="checkbox"/> 010
Power	<input type="checkbox"/> 010	<input type="checkbox"/> 010
Cancel	<input type="checkbox"/> 010	<input type="checkbox"/> 010
Prog. Tamper	<input type="checkbox"/> 010	<input type="checkbox"/> 010

Second digit of each code applies only to 4+2 or expanded (fields *52 & *53) formats.

ZONE TYPE RESTORE ENABLES

<p>*79 ZONE TYPES 1-8. All enabled</p> <p style="text-align: center;"> <input type="checkbox"/> 1 <input type="checkbox"/> 1 <input type="checkbox"/> 1 <input type="checkbox"/> 1 <input type="checkbox"/> 1 <input type="checkbox"/> 1 <input type="checkbox"/> 1 <input type="checkbox"/> 1 <small>1 2 3 4 5 6 7 8</small> </p>	<p>*80 ZONE TYPES 9 & 10. All enabled</p> <p style="text-align: center;"> <input type="checkbox"/> 1 <input type="checkbox"/> 1 <small>9 10</small> </p>
---	---

DESCRIPTION OF 4120XM PROGRAMMING FIELDS

To enter Program Mode, enter Installer code + [8] + [0] + [0].

To set Standard Defaults, press *97.

To access second page of fields, press *94.

To return to first page of fields, press *99.

To exit Program Mode, press *99 or *98. *99 allows re-entry to Program Mode by installer code. *98 prevents re-entry to Program Mode by installer code.

Note that system default values, if not stated in text, are shown underlined>.

*00 Installer Code (0000-9999)	Enter the 4-digit installer code, which is the code reserved for installation company use, but can be used by the customer if needed. This is the only code that can be used to enter the Program mode from the console. This code cannot be used to enter secondary codes, and cannot be used to disarm the system if not used to arm or if Quick Arm was used to arm system. This code is disabled if programming mode is exited by the *98 command. Default = 4-1-2-0.												
*01 Master Security Code (0000-9999)	Enter the 4-digit master security code. Use of a 9 in last position inhibits the Duress feature. This code can assign secondary codes for users 03-70. Default = 1-2-3-4. See fields *15, *29, 1*50 & 1*54 for related security code options. Note: Do not select the same code for Master Code and Installer Code.												
*02 Response Type For Zones 1-8	(00-10; see Field *05).												
*03 Response Type For Zones 9-16	(00-10; see Field *05)												
*04 Response Type For Zones 17-24	(00-10; see Field *05)												
*05 Response Type For Zones 25-27 (00-10)	<p>Enter the 2-digit zone response type using the numerical codes listed below. If zone 7 is to be used for keyswitch Arm/Disarm operation, enter 10 as its response type. For protection zones 28-64 and RF Receiver zones 88-91, see fields 1*01-1*05 & 1*08-1*09.</p> <p>The following is a list of the available response types:</p> <table style="width: 100%; border: none;"> <tr> <td>00 = Assign for unused zones</td> <td>06 = 24-HOUR SILENT</td> </tr> <tr> <td>01 = ENTRY/EXIT #1</td> <td>07 = 24-HOUR AUDIBLE</td> </tr> <tr> <td>02 = ENTRY/EXIT #2</td> <td>08 = 24-HOUR AUXILIARY</td> </tr> <tr> <td>03 = PERIMETER</td> <td>09 = FIRE</td> </tr> <tr> <td>04 = INTERIOR, FOLLOWER</td> <td>10 = INTERIOR, DELAY</td> </tr> <tr> <td>05 = DAY/NIGHT</td> <td></td> </tr> </table>	00 = Assign for unused zones	06 = 24-HOUR SILENT	01 = ENTRY/EXIT #1	07 = 24-HOUR AUDIBLE	02 = ENTRY/EXIT #2	08 = 24-HOUR AUXILIARY	03 = PERIMETER	09 = FIRE	04 = INTERIOR, FOLLOWER	10 = INTERIOR, DELAY	05 = DAY/NIGHT	
00 = Assign for unused zones	06 = 24-HOUR SILENT												
01 = ENTRY/EXIT #1	07 = 24-HOUR AUDIBLE												
02 = ENTRY/EXIT #2	08 = 24-HOUR AUXILIARY												
03 = PERIMETER	09 = FIRE												
04 = INTERIOR, FOLLOWER	10 = INTERIOR, DELAY												
05 = DAY/NIGHT													
*06--*08 Not Used													
*09 Entry Delay #1 (01-15)	Enter the entry delay time (01-15 times 15 seconds or 00 for no delay), up to a maximum delay of 225 seconds (entry 15 times 15 seconds), for the zone assigned to Entry Delay #1. Default = 02. See fields *87 & 1*45 for entry/exit sounds options.												
*10 Exit Delay #1 (01-15)	Enter the exit delay time (01-15 times 15 seconds or 00 for no delay), up to a maximum delay of 225 seconds, for the zone assigned to Exit Delay #1. Default = 03.												
*11 Entry Delay #2 (01-15)	Enter the entry delay time (01-15 times 15 seconds or 00 for no delay), up to a maximum delay of 225 seconds (entry 15 times 15 seconds), for the zone assigned to Entry Delay #2. <i>This delay must be longer than Entry Delay #1.</i> Default = 06.												
*12 Exit Delay #2 (01-15)	Enter the exit delay time (01-15 times 15 seconds or 00 for no delay), up to a maximum delay of 225 seconds, for the zone assigned to Exit Delay #2. Note that this delay must be longer than Exit Delay #1. Default = 08.												

*13 Alarm Sounder Duration (01-15)	Enter the length of time an external sounder or the console's sounder will sound for all audible alarms (multiply entry 01-15 by 2 minutes for actual duration). Minimum 4 minutes for UL. Default = 04 (8 min). See field *21 for Fire Timeout option.
*14 Zone 8 Fast/Slow Response (0=slow/1=fast)	Enter 0 for 350 msec response time or 1 for 10 msec response time. See WIRED ZONES in text.
*15 Keyswitch Enable (0=no/1=yes)	Enter 1 in this field if using 4146 Keyswitch. Also, field *41 must be programmed for EOLR supervision (0). Note that trigger operation is affected. See REMOTE KEYSWITCH OPERATION in text. Also refer to Address 1*57.
*16 Confirmation Of Arming Ding (0=no/1=yes)	Enter 1 to enable 1/2 second external alarm sounding ("ding") at the end of exit delay #1. Enter 0 to disable the "ding".
*17 AC Power Loss Sounding (0=no/1=yes)	Enter 1 if sounding at the console (rapid beeping) when AC power is lost is desired. Enter 0 if no AC power loss sounding is desired.
*18 AC Power Loss Alarm (0=no/1=yes)	Enter 1 to have the external alarm sound after AC power has been out for 4 hours; otherwise enter 0 (no alarm).
*19 AC Randomize (0=no/1=yes)	Enter 1 to randomize AC loss reporting between 10-40 min. after actual AC loss. Enter 0 for normal AC loss reporting (about 2 minutes after actual AC loss).
*20 Not Used	
*21 Disable Fire Time-Out (0=no/1=yes)	Enter 1 to disable (no timeout) the alarm sounder duration (*13) for any zone designated as a fire zone so that fire sounding continues until the system is reset. Enter 0 if normal alarm sounder duration should apply to fire alarms.
*22 Not Used	
*23 Multiple Alarms (0=no/1=yes)	Enter 1 to enable the system to permit multiple audible alarms from a protection zone during one armed interval (as opposed to only one alarm). Enter 0 for only one alarm. Note that multiple alarm soundings will not occur more frequently than allowed by the alarm sounder duration, *13). This selection has no impact on the number of communication messages transmitted.
*24 Not Used	
*25 Burglary Trigger For Response Type 8 (1=enable/0=disable)	When this field is disabled (0), Pin 6 (OUT 3) acts as a burglary trigger only. When enabled (1), pin 6 acts as a burglary trigger and also as a trigger for any zone assigned as type 8 (24-hour auxiliary) using non-burglary devices such as water sensors, temperature sensors, and for personal emergency .
*26 Intelligent Test Reporting (0=no/1=yes)	Enter 1 if it is desired that no test report be sent if any other type of report was recently sent. Enter 0 if test reports are to be sent at the set intervals, regardless of other reports having been sent. Must be 0 for UL applications.
*27 Test Report Interval (024)	Enter interval in hours, 001-199; 000 = no report. This field selects the test report transmission interval. For the test report desired, enter a test code in fields *81 & *82, location 7. Enter 024 for UL. Note: Automatic battery testing is conducted every 24 hours, at which time AC power will be automatically removed for 10 minutes and the battery will be tested under auxiliary current load.
*28 Power Up In Previous State (0=no/1=yes)	Enter 1 if, upon power-up, you want the system to assume the system status prior to power down. Enter 0 if you want the system to always power up in a disarmed state. When the system powers up armed, an alarm will occur 3 minutes after arming if a zone is faulted. When so armed, reports closing as User #7 if open/close reporting for User #7 was enabled in field *39. Must be 1 for UL applications. Note that if the previous state was armed AWAY or STAY, the system may not respond to sensor changes for a small period of time (1-3 min.), which allows time for sensors such as PIRs to stabilize.

***29 Quick Arm**
(0=no/1=yes) Enter 1 to enable arming of the burglary system in any mode by using the # key instead of the security code (just # key depression followed by the command AWAY, STAY, INSTANT or MAXIMUM). When armed AWAY or MAXIMUM, reports closing as User #7 if open/close reporting for User #7 was enabled in field *39. Enter 0 if Quick Arm is not desired. (The 4-digit code must always be used to disarm.)

***30 Touch-Tone Or Rotary Dial**
(Q=R/1=TT) See field 1*33 for Touch-Tone w/Rotary backup
Important!: Do not select a dialing method that is not legally permitted by the telephone company for the particular subscriber. If selecting TouchTone, make sure the subscriber has requested and is paying for TouchTone service. NOTE: Whether or not TouchTone dialing for call placement is permitted, communication by the use of DTMF signaling (Ademco High Speed) will still take place.

***31 PABX Access Code** Enter up to four 2-digit numbers 00-09; B-F (11-15). If not required, enter nothing and proceed to next address; otherwise, enter prefix needed to obtain an outside Telco line. This field may be used alternatively to enter a prefix that can suppress the Telco's call waiting feature from interfering with outgoing transmissions. This prefix is only useful if the Telco option to suppress call waiting has been obtained by your customer. The prefix to be used is 01010700 if rotary dialing is being used or 140700 if TouchTone dialing is being used.

Each entry is a 2-digit entry so as to allow use of hexadecimal digits (B-F). Use the following chart to determine the entry for each digit. Only enter digits required. Do not fill unused spaces. Erase the field by entering *31*.

NUMBER	ENTER	NUMBER	ENTER
0	00	8	08
1	01	9	09
2	02	A	(Do not use)
3	03	B	11
4	04	C	12
5	05	D	13
6	06	E or *	14
7	07	F or #	15

***32 Primary Subscriber Account Number** Enter 3 or 4 numbers 00-09; B-F (11-15). Each digit requires a 2-digit entry so as to allow entry of hexadecimal digits (B-F). If a 3 digit number is to be used, only enter data in the first 6 locations, leaving the last two unfilled. Erase the field by entering *32*. Default=15 15 15 15.

***33 Primary Phone Number** Enter up to 12 digits, 0-9. Do not fill unused spaces. Erase the field by entering *33*. NOTE: Back-up reporting (8 calls are made to the secondary phone number if no acknowledgment is received after 8 attempts to the primary number) is automatic only if there is a secondary phone number (*34) and secondary account number (*90) entered.

***34 Secondary Phone Number** Enter up to 12 digits, 0-9. Do not fill unused spaces. Erase the field by entering *34*. If this field is programmed, a secondary subscriber account number (field *90) *must* also be programmed (can be the same as the primary account number).

***35 Download Phone Number** Only applicable if downloading will be utilized. Enter up to 12 digits (0-9). Do not fill unused spaces. Erase the field by entering *35*.

***36 Download Id Number** Only applicable if downloading will be utilized. Make entries as 2-digit numbers as follows (default =15 15 15 15 15 15 15 15):

00 = 0	03 = 3	06 = 6	09 = 9	12 = C	15 = F
01 = 1	04 = 4	07 = 7	10 = A	13 = D	
02 = 2	05 = 5	08 = 8	11 = B	14 = E	

*37 Download Command Enables (<u>1</u> =yes/ 0=no)	Eight single-digit field entries: Dialer Shutdown, System Shutdown, Not Used (0), Remote Bypass, Remote Disarm, Remote Arm, Upload Program, Download Program. See field 1*53 for Callback disable option. For UL installations, Upload & Download must be enabled; all others must be disabled. Each of the various remote (from the central station) functions can either be enabled or disabled. Disabling a function means that the central station will not be able to perform that function with respect to this system. Enter 1 to enable a function, and 0 to disable a function. For UL installations, all entries must be 0.
*38 Inhibit Bypass Of A Zone (<u>00</u> ; 01-31)	Entering a zone number (01-31 only) prevents that zone from being bypassed by the user. Enter 00 if this feature is not desired (all zones can be bypassed). This selection does not affect fire zones, which can never be bypassed.
*39 Open/Close Reports For Users 1-8 (1=yes/ <u>0</u> =no)	See field *40
*40 Open/Close Reports For Users 9-16 (1=yes/ <u>0</u> =no)	Enter 1 for each user which is to send open/close reports to the central station. Note that user 7 must be enabled if either open/close reporting is desired for keyswitch arming, or if close reporting is desired for Quick Arm and Power Up arm, or if open/close reporting is desired for remote arm/disarm via downloading. Note that users 16-70 are sent as user 15 for traditional communication formats. To receive all user codes, Ademco Contact ID reporting must be used.
*41 EOLR Disable (Zones 2-8) (0=EOLR/ <u>1</u> = no EOLR)	Enter 0 if end-of-line resistors are to be used. Enter 1 if end-of-line resistors are not to be used (normally closed loops that detect only an open and do not require end-of-line resistors). Must be "0" for UL. Note: You must enter "0" (EOLR usage) in this field if a remote keyswitch is being used (also see field *15).
*42 Dial Tone Pause (<u>0</u> /1/2)	Enter the desired wait time for dial tone detection as follows: Enter single digit, 0 = 5 seconds; 1 = 11 seconds; or 2 = 30 seconds. Must be 0 for UL.
*43 Dial Tone Detect (<u>1</u> =true tone/0=pause)	Enter 1 if true dial tone detection is desired. Enter 0 if only a delay before dialing (same as programmed in field *42) is desired. The latter may be necessary in high-noise environment Telco networks where noise can be confused with dial tone, resulting in premature dialing.
*44 Ring Detection Count (<u>00</u> ; 01-15)	Only applicable if central station initiated downloading will be used. Enter 00 to disable ring detection. Enter 01-14 for ring counts of 1-14. Enter 15 to select mode that gets around telephone answering machines connected to the same phone line. In the latter mode, the system upon hearing one ring followed by nothing, will not answer but will ready itself to pick up the next incoming call received within the next 30 seconds on the first ring (the downloader calling again).
*45 Primary Format (<u>0</u> /1/2/3)	Enter the appropriate number for the primary format as follows: 0=Low Speed; 1=Contact ID; 2=Ademco High Speed; 3=Ademco Express
*46 Low Speed Format (Primary) (<u>0</u> /1)	Enter the appropriate value: 0=Ademco Low Speed; 1=Sescoa/Radionics
*47 Secondary Format (<u>0</u> /1/2/3)	Enter the appropriate number for the secondary format: 0=Low Speed; 1=Contact ID; 2=Ademco High Speed; 3=Ademco Express
*48 Low Speed Format (Secondary) (<u>0</u> /1)	Enter the appropriate value: 0=Ademco Low Speed; 1=Sescoa/Radionics
*49 Checksum Verification (<u>0</u> = no/1 = yes)	Enter 1 to send a verification digit to validate the message at the receiver without having to send two message rounds. NOTE: Selection applies to both primary and secondary phone numbers, and is valid for 3+1, 4+2, and Ademco High Speed reports. Enter 0 if not desired.

*50	SESCOA/Radionics (1= Ses/Q= Rad)	Enter 0 if Radionics format is to be used with hexadecimal 0-9, B-F reporting. Enter 1 if SESCOA format is to be used with only numeric reporting (0-9). NOTE: Selection applies to both primary and secondary phone numbers.
*51	Dual Reporting (Q=no/1=yes)	Enter 1 if it is desired that all reports are sent to both primary and secondary phone numbers. If dual reporting is desired and Ademco High Speed format is to be used at all, it must be selected as both the primary and secondary transmission formats. If used with Split Reporting "1" option (1*34), alarms go to both primary & secondary numbers, while all other reports go to secondary only. If used with Split Reporting "2" option, open/close and test messages go to both lines, while all other reports go to primary.
*52	Standard/Expanded Report For Primary	Six 1-digit field entries: Alarm, Restore, Bypass,, Trouble, Open/Close, Low Battery. Enter 0 for Standard or 1 for Expanded reporting for the primary phone line . Note: Expanded overrides 4+2 format.
*53	Standard/Expanded Report For Secondary	Six 1-digit field entries: Alarm, Restore, Bypass,, Trouble, Open/Close, Low Battery. Enter 0 for standard or 1 for expanded reporting for the secondary phone line Note: Expanded overrides 4+2 format.
*54	Report Code Digit For Zones 1-8	Alarm code digit for 3+1, 4+1, 4+2, and Ademco Express, for a standard report. In High Speed, this digit assigns the reporting channel. For Contact ID, a non-zero digit enables reporting for the corresponding zone.
*55	Report Code ID Digit For Zones 1-8	ID digit for an expanded 3+1 or 4+1 report, or for a 4+2 or Ademco Express report. If this ID digit equals 0, only 3+1 or 4+1 (or 4+1 Express) non-expanded messages will be sent. In High Speed or Contact ID format, this field is ignored.
*56	Report Code Digit For Zones 9-16	See field *54
*57	Report Code ID Digit For Zones 9-16	See field *55
*58	Supervisory & Restore Codes For Zones 1-16	Five 2-digit field entries: Alarm Restore, Trouble, Trouble Restore, Bypass, Bypass Restore.
*59	Report Code Digit For Zones 17-24	See field *54
*60	Report Code ID Digit For Zones 17-24	See field *55
*61	Report Code Digit For Zones 25-32	See field *54
*62	Report Code ID Digit For Zones 25-32	See field *55
*63	Supervisory & Restore Codes For Zones 17-32	Five 2-digit field entries: Alarm Restore, Trouble, Trouble Restore, Bypass, Bypass Restore.
*64	Report Code Digit For Zones 33-40	See field *54
*65	Report Code ID Digit For Zones 33-40	See field *55
*66	Report Code Digit For Zones 41-48	See field *54
*67	Report Code ID Digit For Zones 41-48	See field *55

*68	Supervisory & Restore Codes For Zones 33-48	Five 2-digit field entries: Alarm Restore, Trouble, Trouble Restore, Bypass, Bypass Restore.
*69	Report Code Digit For Zones 49-56	See field *54
*70	Report Code ID Digit For Zones 49-56	See field *55
*71	Report Code Digit For Zones 57-64	See field *54
*72	Report Code ID Digit For Zones 57-64	See field *55
*73	Supervisory & Restore Codes For Zones 49-64	Five 2-digit field entries: Alarm Restore, Trouble, Trouble Restore, Bypass, Bypass Restore.
*74	Report Code Digit For 4219 and 2nd RF Receiver	Eight 2-digit field entries: The 5th, 6th, and 7th must be 00. <i>Notes:</i> 81 = 4219 supervision. 83 = 4219 tamper. 88 = 2nd receiver not receiving any transmitter signals.
*75	Report Code ID Digit For 4219 & 1st RF Receiver	Eight 2-digit field entries: The 5th, 6th, and 7th must be 00. <i>Notes:</i> 81 = 4219 supervision. 83 = 4219 tamper. 88 = 2nd receiver not receiving any transmitter signals.
*76	Report Code Digit For RF Receivers and Panics	Eight 2-digit field entries: The 4th must be 00. <i>Notes:</i> 89 = 2nd receiver not responding to panel. 90 = 1st receiver not receiving any transmitter signals. 91 = 1st receiver not responding to panel. 95 = (1 + *) or (A) Panic. 96 = (3 + #) or (C) Panic. 99 = (* + #) or (B) Panic.
*77	Report Code ID Digit For RF Receivers and Panics	Eight 2-digit field entries: The 4th must be 00. <i>Notes:</i> 89 = 2nd receiver not responding to panel. 90 = 1st receiver not receiving any transmitter signals. 91 = 1st receiver not responding to panel. 95 = (1 + *) or (A) Panic. 96 = (3 + #) or (C) Panic. 99 = (* + #) or (B) Panic.
*78	Supervisory & Rest Codes For Receivers & Panics	Five 2-digit field entries: Alarm Restore, Trouble, Trouble Restore, Bypass, Bypass Restore.
*79	Zone Type Restore For Types 1-8	Enter 1 to enable restore reporting for individual zone types. Enter 0 if no restore report is desired for a zone type.
*80	Zone Type Restore For Types 9 & 10	See field *79
*81	System Non-Alarm Code First Digits	Ten 2-digit field entries: Close, Open, Low Battery, Low Battery Restore, AC Loss, AC Restore, Test , Power, Cancel,Program Tamper.
*82	System Non-Alarm Code Second Digits	Ten 2-digit field entries: Close, Open, Low Battery, Low Battery Restore, AC Loss, AC Restore, Test , Power, Cancel,Program Tamper.

*83 First Test Report Time	One 2-digit field entry: Enter the time from the time that the programming mode is exited that the first test report shall be transmitted, and/or first battery test initiated. 00 entry signifies immediately upon exiting. Default = 12 hours. See fields *81 & *82 for assigning the Test Report code.
*84 Swinger Suppression (00; 01-15)	This option limits the number of messages (Alarms or Troubles) sent for a specific channel in an armed period (Swinger Suppression) before additional reports from that channel are inhibited. This selection is system-wide. NOTE: If zero is selected, all Alarm or Trouble codes are reported. Must be "00" (disabled) for UL. Default=15.
*85-86 Not Used	
*87 ENTRY WARNING (1=cont/0=3 beeps)	Enter 0 for 3 short beeps, or 1 for slow beeps that continue for the entire entry delay period.
*88 Burg. Alarm Comm. Delay (Q/1)	Enter 0 for no delay on burglary alarm communication, or 1 for 16-second delay (no delay on 24-hour reports).
*89 Restore Report Timing (Q/1/2)	Enter 0 for instant restore report, as zone restores. Enter 1 for reporting after bell timeout if zone restored. Enter 2 for restore report when system is subsequently disarmed
*90 Secondary Subscriber Acct #	Enter 3 or 4 numbers 00-09; B-F (11-15). Each number requires a 2-digit entry so as to allow entry of hexadecimal digits (B-F). If a 3-digit number is to be used, only enter data in the first 6 locations, leaving the last two unfilled. Default=15 15 15 15. Use the chart in field *31 to determine the entry for each digit. Erase the field by entering *90*. NOTE: This field <i>must</i> be programmed if a secondary phone number is used (field *34). This account number can be the same as the primary account number.

SECOND PAGE OF FIELDS (press *94)

1*00 Open/Close Reports For Users 17-22 & 23-70 (1=yes; Q=no)	See Fields *39 and *40 for Users 1-16.
1*01 Response Type For Zones 28-32	(See Field *05)
1*02 Response Type For Zones 33-40	(See Field *05)
1*03 Response Type For Zones 41-48	(See Field *05)
1*04 Response Type For Zones 49-56	(See Field *05)
1*05 Response Type For Zones 57-64	(See Field *05)
1*06-1*07 Not Used	
1*08 Assign Response Types For Zones 81-88	Eight 2-digit field entries: The 2nd, 4th, 5th, 6th, and 7th must be 00. 81 (4219 supervision), 82 (not used), 83 (4219 Tamper), 84 (not used), 85 (not used), 86 (not used), 87 (not used), 88 (2nd Receiver).

1*09 Response Type For Zones 89-91 (See Field *05 for response types)	Three 2-digit field entries: 89 (2nd Receiver), 90 (1st Receiver), 91 (1st Receiver). For UL applications, use of 1 or 2 RF RCVRs requires enabling their respective faults (88-91) as applicable (type 5). 88 & 90 = RCVR not receiving transmitter signals. 89 & 91 = RCVR not responding, bad connection to panel.
1*10-1*17 Not Used	
1*18 Select Wireless For Zones 1-8 (See field 1*25)	Enter 1 to enable a zone as wireless, otherwise enter 0 for hard-wire zones. If zones 1-8 are to be used as wired zones, be careful not to select those zones for RF because they will then be ignored, since the wireless option takes precedence over hard-wire zones. NOTE: Only up to 8 wireless zones (4281M or H) or up to 4 wireless zones (4281L) may be selected within the range of 1-63.
1*19 Select Wireless For Zones 9-16	(See field 1*18)
1*20 Select Wireless For Zones 17-24	(See field 1*18)
1*21 Select Wireless For Zones 25-32	(See field 1*18)
1*22 Select Wireless For Zones 33-40	(See field 1*18)
1*23 Select Wireless For Zones 41-48	(See field 1*18)
1*24 Select Wireless For Zones 49-56	(See field 1*18)
1*25 Select Wireless For Zones 57-63	(See field 1*18)
1*26 First RF Receiver Select (0=no/1=yes)	Enter 1 if first Receiver is installed. Enter 0 if no Receiver is installed.
1*27 Second RF Receiver Select (0=no/1=yes)	Enter 1 if 2nd 4281 Receiver is installed. Enter 0 if only one or no Receiver is installed. If second Receiver is installed, set DIP switch on 4281 (see Fig. 2).
1*28 RF Transmitter Low Battery Annunciation (0/1)	Enter 0 if audible beep and display annunciation upon RF transmitter low battery condition is desired only in disarmed state. Enter 1 if audible beep and display is desired in both armed and disarmed states. Must be 1 for UL.
1*29 Transmitter Low Battery Report Enable (0=no/1=yes)	Enter 1 if a trouble message for RF transmitter low battery conditions is to be sent to the central station. Enter 0 if no report for transmitter low battery is desired. Note that a trouble message will be sent for a transmitter supervision failure independent of this selection. Must be "1" for UL.
1*30 RF Receiver Supervision Check-In Interval (00; 02-15)	Enter the check-in monitoring interval in 2-hour increments; enter 02-15 (entry times 2=4-30 hours). Failure of a receiver to receive any RF signal within the time entered will result in activation of the response type programmed for zone 90 for the first Receiver and zone 88 for the second Receiver and their related communication reports. Enter 00 to disable supervision. NOTES: If a zero is programmed, supervision of the RF receiver will be disabled (response types for zones 88 and 90 are disabled). Default=6. Max. "6" (12 hr) for UL.
1*31 RF Transmitter Check-In Interval (00; 02-15)	Enter the check-in monitoring interval in 2-hour increments; enter 02-15 (4-30 hours). Failure of an individual transmitter to send a supervision signal within the time entered will result in a trouble response and related communication report. Entry 00 disables transmitter supervision. Max. "6" (12 hr) for UL. Default=12.

1*32 Not Used	
1*33 Touch-Tone W/Rotary Backup (Q=no/1=yes)	Enter 1 to enable Rotary back-up if communicator is not successful on dialing using TouchTone DTMF on first attempt. Enter 0 if this option is not to be used.
1*34 Communication Split Report Selection (Q/1/2)	Enter 0, 1, or 2, in accordance with the following: 0 = split reporting disabled; 1 = alarm, alarm restore & cancel reports sent to primary Telco number, all others to secondary Telco number; 2 = open/close & test reports sent to secondary Telco number and all other reports to primary. See *51 for split/dual reporting comments.
1*35-1*39 Not Used	
1*40 Armed Stay Dialer Report (First Digit)	The dialer can be made to send a report when the system is armed in the STAY mode,as follows: If any Low Speed report is beong used, the report codes are assigned in this 2-digit field (and field 1*41 below), which is similar to programming a CLOSE report in fields *81 and *82. If Ademco High Speed format is being used, a normal closing report will be sent. If Ademco Contact ID is used, a new code, R441, will be sent. Note that 685 receivers that do not have software revision 4.5 or higher will print an error message in place of the English text.
1*41 Armed Stay Dialer Report (Second Digit)	See Field 1*40.
1*42-1*43 Not Used	
1*44 RF Keypad Tamper Detect (Q=no/1=yes)	Enter 1 to enable tamper detection on wireless keypad. Enter 0 if tamper detection is not desired. If this feature is enabled, any attempt to tamper by means of many trial entries at a wireless keypad will be blocked by the control panel. If more than 40 key depressions are received without a valid sequence (arm, disarm, etc.), the Control panel will disable the wireless keypad. The inhibit is removed once a valid key sequence is received from a wired keypad.
1*45 Console Annunciation During Exit Delay (Q=no/1=yes)	Enter 1 if beeps from the consoles during exit delay is desired. Enter 0 for no console sound during exit delay.
1*46 Auxillary Output Enable (0/1/3)	Enter 0 if ground start output is required; enter 1 if the TERMINAL 9 output will be used to produce an open/close trigger, 3 if zone 1 is to use EOLR supervision. "2" is unused. NOTE: Only one of the above options can be active within a system.
1*47 Chime Annunciation On External Sounder (Q=no/1=yes)	Enter 1 for chime annunciation using the external alarm sounder (if not desired, enter 0).
1*48 Wireless Keypad Disable (Q=no/1=yes)	Enter 1 if wireless keypad is not to be used (disable keypad). Enter 0 if wireless keypad is used.
1*49 Disable Trouble Sounder For RF Supervision (0=no/1=yes)	Enter 1 to disable trouble sounding for transmitter check-in failure; enter 0 if audible trouble sounding is desired. Must be "0" for UL.
1*50 Babysitter Code (Q=no/1=yes)	Enter 1 if it is desired that User 22 cannot disarm the system unless the system was armed by User 22.

1*51 4281 House ID (01-31)	If using 4281 RF Receivers, enter the house ID.
1*52 Cancel Report Restriction (0/1)	Enter 1 for no restriction. Entry 0=within Bell Timeout period only.
1*53 Download Callback (0=yes/1=no)	Enter 1 if callback not required when downloading. Enter 0 if callback is required. Must be "0" for UL.
1*54 High Security Mode (0/1)	Enter 1 for 6-digit high security mode. Six digits = 2-digit user number + 4-digit code. Enter 0 for normal 4-digit security code operation.
1*55-1*56 Not Used	
1*57 Trigger Mode (0/1/2/3)	Enter 0, 1, 2, or 3. See Table below.
1*58 4219 First Zone Number (00/09-57)	Set to 00 if no 4219s are used. If using a 4219, set to the first zone number which will be assigned to zone A on the 4219. The remaining 7 zones on the 4219 will be the next 7 zone numbers. See 4219 WIRED ZONE EXPANDER in the text.

ADDRESS		Trigger Output 1	Trigger Output 2	Trigger Output 3
1*57 Trigger Mode	*15 Keyswitch			
0	0	FIRE LRR TRIGGER	PANIC LRR TRIGGER	BURG LRR TRIGGER
	1	KEYSWITCH ARMED LED	KEYSWITCH READY LED	TRIGGER
1	0	FIRE LRR TRIGGER	PANIC LRR TRIGGER	ZONE 6
	1	KEYSWITCH ARMED LED	KEYSWITCH READY LED	GLASS BREAK RESET
2	0 1 not allowed	FIRE LRR TRIGGER	REMOTE SOUNDER	BURG LRR TRIGGER
3	0 1 not allowed	FIRE LRR TRIGGER	REMOTE SOUNDER	ZONE 6 GLASS BREAK RESET

NOTE: IF ADDRESS 1*57 IS SET FOR "2" OR "3", ADDRESS *15 MUST BE 0.

Programming Zone Descriptions (Alpha Consoles)

General If using an Alpha console, a user-friendly English language description/location of all protection zones, keypad panics, and 4281 supervision faults can be programmed into the system. Each description can be composed of a combination of words (up to a maximum of 3) that are selected from a vocabulary of approximately 220 words stored in memory, and any word can have an "s" or " 's " added to it. In addition, up to 20 installer-defined words can be added to those already in memory. Thus, when an alarm or trouble occurs in a zone, an appropriate description for the location of that zone will be displayed at the console. An installer's message can also be programmed which will be displayed when the system is "Ready" (ex. THE PETERSON's).

Note: Alpha descriptor entry can be accomplished locally at the Alpha console or remotely using a 4130PC Downloader.

Entering Zone Descriptions

1. Enter programming mode as described previously.
2. Key *93. The following will be displayed: * ZN ??
In this mode, the console keys have these functions:
 - [3] Scrolls both alphabet and actual words in ascending alphabetical order.
 - [1] Scrolls both alphabet and actual words in descending alphabetical order.
 - [2] Adds or removes an "s" or " 's " to a vocabulary word.
 - [6] Toggles between alphabet and actual word list, and used to accept desired entries.
 - [8] Saves the zone description in the system's memory.
 - [#] # plus zone number will display the description for that zone.

NOTE: When programming descriptors for zones 95-99 (panics), the following numbers **must** be entered in place of the corresponding zone number.

ZONE NUMBER	PANIC KEY PAIR	PANIC SINGLE KEY	ENTER NUMBER
95	1 + *	A	94
96	3 + #	C	95
99	* + #	B	96

3. Key *01 to begin entering the description for zone 1, (key *02 for zone 2, *03 for zone 3 etc.). The following will be displayed: * ZN 01 A
Note that the first letter of the alphabet appears after the zone number, and that the zone number is automatically included with the proposed description.
4. Select the first letter of the desired description (note that "A" is already displayed). Use key [3] to advance through the alphabet and key [1] to go backward. For example, assume the desired description for zone 1 is BACK DOOR. Press key [3] repeatedly (or hold down the key) until "B" appears, then press key [6]. to display the first available word beginning with B. Repeatedly press key [3] to advance through the available words until the word BACK is displayed. Press key [1] to move backward through the word list.
To add an "s" or " 's", press the [2] key. The first depression adds an "s", the second depression adds an " 's ", the third depression displays no character (to erase the character), the fourth depression adds an "s", etc.
To accept the chosen word, press the [6] key, which toggles back to the alphabet list.
5. For selection of the next word (DOOR), repeat step 4, but press key [3] until the desired first letter of the next word appears (in this example, "D"). Then press key [6] to display the first available word beginning with "D". Press key [3] repeatedly until the desired word (DOOR) appears. To accept the word, press the [6] key, which again toggles back to the alphabet list.
6. When all desired words have been entered, press key [8] to store the description in memory.
7. To review the zone descriptions, key [#] plus zone number (e.g., #01). To edit zone descriptions, key [*] plus zone number (e.g., *01)
8. To exit the zone description mode, key *99.

Adding Custom Words

Up to 20 installer-defined words can be added to the built-in vocabulary. Each of the 20 "words" can actually consist of several words, but bear in mind that a maximum of 10 characters can be used for each word string. To create the custom word or word string, proceed as follows:

1. Enter the programming mode.
2. Key *93. The following will be displayed: *ZN ??
3. Now key 00 to get into the mode which will allow the custom words to be created. The following will be displayed: *ED ??

In this mode, the keys perform the following functions:

- [3] Advances through alphabet in ascending order.
 - [1] Advances through alphabet in descending order.
 - [6] Selects the desired letter, and moves the cursor to the right one space.
 - [4] Moves the cursor one space to the left.
 - [7] Inserts a space at the cursor location, erasing any character at that location.
 - [8] Saves the new word in the system's memory.
 - [*] Returns to description entry mode.
4. Key the number of the custom word or word string to be created (01-20). For example, if you are creating the first word (or word string), enter 01; when creating the second word, enter 02, and so on. A cursor will now appear at the beginning of the second line.
 5. Use the [3] key to advance through the alphabet (numbers, symbols and special characters are included). Use the [1] key to move back through the alphabet.
Important: Custom words must begin with an alphabetic character. If numbers or symbols are used as the first character, the word will not be saved.
 6. When you have reached the desired character, press the [6] key to select it. The cursor will then move to the right, in position for the next character.
 7. Repeat steps 5 and 6 to create the desired word (or words). Note that the [4] key can be used to move the cursor to the left if necessary, and that key [7] can be used to enter a blank (or to erase an existing character). Each word or word string cannot exceed 10 characters.
 8. Press the [8] key to save the custom word(s) and return to the *ED ?? display. The custom word (or string of words) will be automatically added to the built-in vocabulary at the end of the group of words beginning with the same letter.
 9. Repeat steps 4 through 8 to create up to 19 additional custom words (or word strings).
 10. Press the [*] key to return to the *ZN ?? display, and follow the zone description entry procedure to assign the new words to a zone description.
 11. Key *99 to exit the zone description programming mode.

Creating A Custom Message Display (Installer's Message)

Normally, when the system is in the disarmed state, the following display is present on the Console.

```
****DISARMED****  
READY TO ARM
```

Part or all of the above message can be modified to create a custom installer message. For example, ****DISARMED**** on the first line or READY TO ARM on the second line could be replaced by the installation company name or phone number for service. Note that there are only 16 character spaces on each of the two lines. To create a custom display message, proceed as follows:

1. Enter the programming mode.
2. Key *93. The following will be displayed: *ZN ??
3. Key 00. The following will appear: *ED ??
4. Key 00 again. The following will appear:

```
****DISARMED****  
READY TO ARM
```

A cursor will be present at the extreme left of the first line (over the first "star"). The [6] key is used to move the cursor to the right and the [4] key to move the cursor to the left. Key [7] may be used to insert spaces or erase existing characters.

5. For example, to replace READY TO ARM with the message SERVICE:424-0177, proceed as follows:

Press the [6] key to move the cursor to the right, and continue until the cursor is positioned over the first location on the second line.

Press the [3] key to advance through the alphabet to the first desired character (in this case, "S"). Use the [1] key to go backward, when necessary. When the desired character is reached, press [6]. The cursor will then move to the next position, ready for entry of the next character (in this example, "E"). When the cursor reaches a position over an existing character, pressing the [3] or [1] key will advance or back up from that character in the alphabet. Proceed in this manner until all characters in the message have been entered.

6. To store this new display message in memory, press the [8] key.
7. Press the [*] key to return to the * ZN ?? display. To confirm that the new message has been stored in memory, press 00 and then press 00 again. The new message should be displayed.
8. Key +99 to exit the descriptor/programming mode.

STANDARD VOCABULARY OF WORDS STORED IN MEMORY* (ALPHA CONSOLES ONLY)

AIR	COATROOM	FREEZER	MAIDS	RF	TRAP
ALARM	COLLECTION	FRONT	MAIN	RIGHT	ULTRA
ALCOVE	COMBUSTION	FUR	MASTER	ROOM	UP
ALLEY	COMPUTER	FURNACE	MAT	ROOF	UPPER
AMBUSH	CONTACT		MEDICAL		UPSTAIRS
AREA		GALLERY	MEDICINE	SAFE	UTILITY
APARTMENT	DAUGHTERS	GARAGE	MICROWAVE	SCREEN	
ART	DELAYED	GAS	MONEY	SENSOR	
ATTIC	DEN	GATE	MONITOR	SERVICE	VALVE
AUDIO	DESK	GLASS	MOTHERS	SHED	VAULT
AUXILIARY	DETECTOR	GUEST	MOTION	SHOCK	VIBRATION
	DINING	GUN	MOTOR	SHOP	VOLTAGE
BABY	DISCRIMINATOR		MUD	SHORT	
BACK	DISPLAY	HALL		SHOW	WALL
BAR	DOCK	HEAT	NORTH	SIDE	WAREHOUSE
BARN	DOOR	HIGH	NURSERY	SKYLIGHT	WASH
BASEMENT	DORMER	HOLDUP		SLIDING	WEST
BATHROOM	DOWN	HOUSE	OFFICE	SMOKE	WINDOW
BED	DOWNSTAIRS		OIL	SONIC	WINE
BEDROOM	DRAWER	INFRARED	OPEN	SONS	WING
BELL	DRIVEWAY	INSIDE	OPENING	SOUTH	WIRELESS
BLOWER	DRUG	INTERIOR	OUTSIDE	SPRINKLER	WORK
BOILER	DUCT	INTRUSION	OVERFLOW	STAMP	
BOTTOM			OVERHEAD	STATION	XMITTER
BOX	EAST	JEWELRY		STEREO	
BREAK	ELECTRIC		PAINTING	STORE	YARD
BUILDING	EMERGENCY	KITCHEN	PANIC	STORAGE	
BURNER	ENTRY		PASSIVE	STORY	ZONE
	EQUIPMENT	LAUNDRY	PATIO	STRESS	
CABINET	EXECUTIVE	LEFT	PERIMETER	STRIKE	0
CALL	EXIT	LEVEL	PHONE	SUMP	1ST
CAMERA	EXTERIOR	LIBRARY	PHOTO	SUPERVISED	2ND
CAR		LIGHT	POINT	SUPERVISION	3RD
CASE	FACTORY	LINE	POLICE	SWIMMING	4TH
CASH	FAILURE	LIQUOR	POOL	SWITCH	5TH
CCTV	FAMILY	LIVING	POWER		6TH
CEILING	FATHERS	LOADING		TAMPER	7TH
CELLAR	FENCE	LOCK	QUAD	TAPE	8TH
CENTRAL	FILE	LOOP		TELCOPHONE	9TH
CIRCUIT	FIRE	LOW	RADIO	TELLER	
CLIP	FLOOR	LOWER	REAR	TEMPERATURE	
CLOSED	FLOW		RECREATION	THERMOSTAT	
COIN	FOIL	MACHINE	REFRIG	TOOL	
COLD	FOYER	MAGNETIC	REFRIGERATION	TRANSMITTER	

*Note: This factory-provided vocabulary of words is subject to change.

Section 9. DOWNLOADING PRIMER

What Is Downloading?

Downloading allows the installer or central station operator to remotely access, program, and control the security system over normal telephone lines. Anything that can be done directly from the keypad can be done remotely, using DOWNLOADING. To Download, the following is required:

1. An IBM PC, or compatible computer with MS DOS 3.1 or higher, to run the DOWNLOADING program. MS DOS stands for: MicroSoft Disk Operating System.
2. A HAYES 1200 SMARTMODEM (external: level 1.2 or higher; internal: level 1.1 or higher). If these levels cannot be found locally, an external modem can be purchased from ADEMCO, or contact HAYES for a free update. *Other brands are not compatible, even if claimed to be 100% compatible.*
3. 4130PC V-LINK[®] DOWNLOADING software, from ADEMCO. This software is available in both 3-1/2" (4130P3-3) and 5-1/4" diskettes, and includes a complete User's Manual.

How Does Downloading Work?

At the protected premises, the Control panel must be connected to the existing telephone line (refer to the PHONE LINE CONNECTIONS section). No programming of the panel is required before downloading to an initial installation. To download, do the following:

1. At the console, enter the installer code + [#] + [5]. The panel temporarily enables a ring count of 5 and sets the Download Callback option to "1" (callback not required).
2. Call the panel using the downloader software set to "FIRST COMMUNICATION" mode.
3. The downloader will establish a session with no callback. The panel information can then be downloaded.

In order to remotely access, control, or program the alarm panel, a "link" must be established between the computer and the control panel, as follows:

1. The computer calls up the Control panel. (The phone number for each customer is entered into the customer's account file on the computer).
2. The Control panel "answers" at the pre-programmed ring count and executes a handshake with the computer.
3. The computer sends a request for call-back to the Control, unless call-back is not required.
4. The panel acknowledges the request and hangs up. During the next few seconds, the Control will process the request making sure certain encrypted information, received from the computer, matches its own memory.
5. Upon a successful match, the Control panel will seize the phone line and call the computer back, unless call-back is not required.
6. The computer answers, usually by the second ring, and executes a handshake with the panel.
7. The panel then sends other default information to the computer. If this information matches the computer's information, a successful link is established. This is known as being "ON-LINE".

ADVISORIES:

1. Alarm and trouble responses and reports are disabled during on-line time. Should an event occur during this time, the response will take place and the report will go through as soon as the remote access sequence is completed. Alarm and trouble conditions are not ignored, they are simply delayed.
2. The keypads are inactive during downloading communication, and resume normal functions after hang up. All keypad entries are ignored during on-line time.

What Can Be Done Once Panel Is "On-Line"?

- Arm the System in the Away Mode; Disarm the System
- Bypass a Zone
- Force the System to Accept a New Program Download
- Shut Down Communication (dialer) Functions (non-payment of monitoring fees in an owned system)
- Shut Down all Security System Functions (non-payment for a leased system)
- Inhibit Local Keypad Programming (prevents takeover of your accounts)
- Leave a message for customer (5137 ONLY)
- Command the System to Upload a Copy of its Resident Program to the office
- Read: Arming Status, AC Power Status, List of Faulted Zones, List of Bypassed Zones, 10-Day Alarm History Log, 10-Day Trouble History Log, List of Zones Currently in Alarm, List of Zones Currently in Trouble, List of RF sensors with low battery conditions

How Secure Is Downloading?

Accessing the Control from a remote location is protected against compromise by the use of 4 levels of protection:

1. *Security Code Handshake:* The subscriber's account number as well as an 8-digit ID number (known only to the office) must be matched between the Control and computer.
2. *Hang-Up and Call-Back:* The Control panel will "hang-up" and call the computer back at the pre-programmed number only if the security codes match.
3. *Data Encryption:* All data that is exchanged between the computer and Control is encrypted to reduce the possibility of anyone "tapping" the line and corrupting data.
4. *Operator Access Levels:* Up to 15 operators can have access to the DOWNLOADER, each having their own log-on code. However, each operator can be assigned one of three levels of access in both FILE and COMMAND functions, as follows:

FILE ACCESS:

Read Only: able only to look at the database; cannot change any information, and cannot see the customer's access codes.

Part Read/Write: able to look at and change all information. except the customer's access codes.

Full Read/Write: able to look at and change any and all information in the database.

CONTROL/COMM ACCESS:

Read Only: able only to Upload and arm the system. Not able to DISARM, BYPASS, or change any information.

Part Read/Write: able to ARM, BYPASS, UPLOAD, DOWNLOAD but cannot shutdown the system.

Full Read/Write: able to perform all control and status commands, as well as shutdown all or part of the system.

Notes:

1. Each time the Control panel is accessed (whether successful or unsuccessful), a PROGRAM TAMPER report (*40) is sent to central station, if programmed.
2. When downloading, the console will display "MODEM COMM" (Alpha consoles) or "CC" (Fixed-word consoles)
3. Whenever a download or a save is done, an automatic time stamp is done, indicating the date and time of the last download (or save) and the operator ID number.
4. The average time for a complete download, including initial call-up, hang-up and call-back is under 4 minutes.
5. A complete hard copy of each individual account can be obtained by connecting a printer to the computer. Refer to your computer owner's manual or contact your dealer for printer recommendations.

Direct Wire Downloading

General The 4120XM can be downloaded at the office or installation site without using a modem or telephone line by using 4130PC Downloading Software and a 4100SM Serial Module.

The installer simply connects the Downloading PC's serial port to the control via the 4100SM, thereby reducing downloading equipment cost while retaining the user-friendly benefits of using downloader software for in-office or on-site programming and troubleshooting.

The direct wire downloading connection is to be temporary, and is not part of the permanent installation. Direct wire downloading is meant as a tool for the installer during the installation process.

Direct Wire Downloading Connections

Direct wire downloading connections are made to the control's console lines via alligator clips (supplied with the 4100SM Serial Module), as shown in Figure 8 below. The required connections from the 4100SM to the Downloader PC are shown in Diagrams 2, 3, and 4 in the 4100SM Installation Instructions; the procedure for direct wire downloading is also contained in that manual.

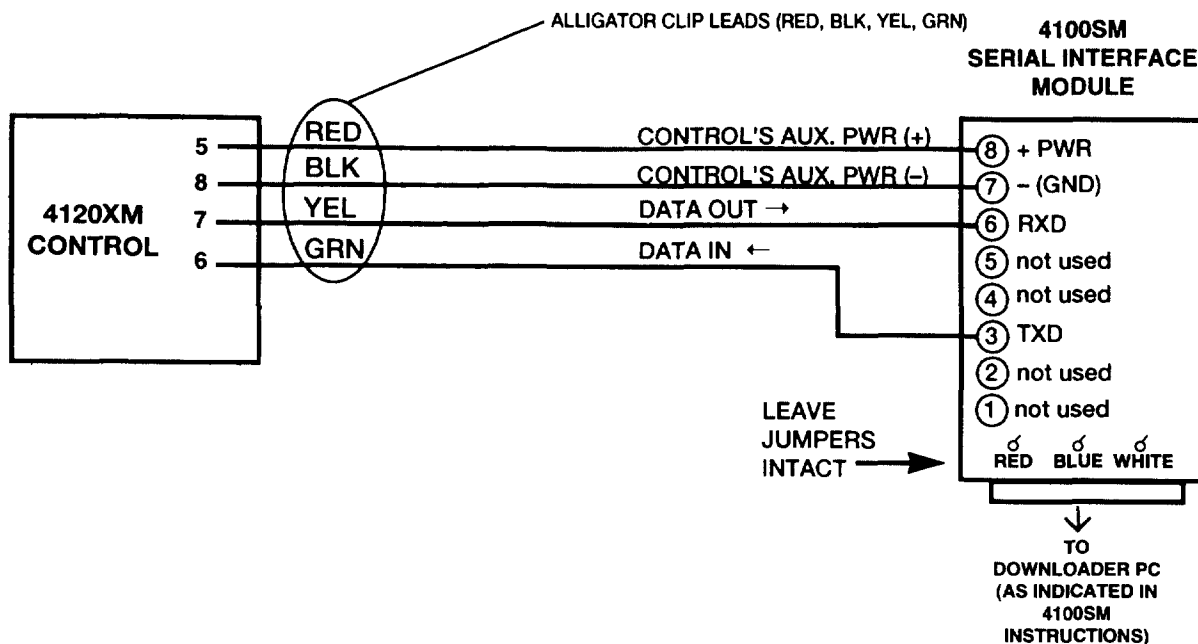

Figure 8. DIRECT WIRE DOWNLOADING CONNECTIONS

Section 10. TESTING THE SYSTEM

Using The Test Mode

After the installation is completed, the Security System should be thoroughly tested as follows:

1. With the System in the disarmed state, check that all zones are intact. If **DISARMED - Press * to show faults** (Alpha consoles) or **NOT READY** (Fixed-word consoles) is displayed, press the [*] key to display the descriptors of the faulted zone(s). Restore faulted zone(s) if necessary, so that *****DISARMED***/READY TO ARM** (Alpha consoles) or **READY** (Fixed-word consoles) is displayed.
2. Enter the security code and press the TEST key. The external sounder (if used) should sound for 3 seconds and then turn off (the system is operating on the back-up battery only at this time).

NOTE 1. The system will not enter the Test mode if the battery voltage is too low, if the battery is not connected, or if any communication messages are waiting to be transmitted.

NOTE 2. As a reminder that the system is in the Test mode, the Console will sound a single beep at 15-second intervals if no protection zones are violated.

NOTE 3. In the Test mode, no alarm reports will be sent to the central station. Also, the external sounder (if used) will not be activated.

Doors and Windows

Open and close each protected door and window in turn. Each action should produce three beeps from the Console. The descriptor for each protection zone will appear on the Console display.

Motion Detectors

Walk in front of any interior motion detectors. Listen for three beeps when the detector senses movement. While it is activated, its descriptor will remain displayed on the Console. Note that wireless PIRs will have a 3-minute lockout between transmissions to conserve battery life (remove cover for walk test to override the 3-minute lock-out).

Smoke Detectors

Follow the test procedure provided by the manufacturer of each smoke detector to ensure that all detectors are operational and are functioning properly.

NOTE: A 2-wire smoke detector display will not clear until the Test mode is exited.

Turn Off Test Mode

Enter the security code and press the OFF key.

Armed System Test

Important! A message will be sent to the central station during the following tests. Notify the central station that a test will be in progress.

NOTE: A display of **"COMM. FAILURE"** (Alpha consoles) or **"FC"** (Fixed-Word consoles) indicates a failure to communicate (no Kissoff by the receiver at the central station after the maximum number of transmission attempts is tried). If this occurs, verify that the phone line is connected, the correct report format is programmed, etc.

1. Arm the system and fault one or more zones. Silence alarm sounder(s) each time by entering the code and pressing OFF. Check that Entry/Exit delay zones provide the assigned delay times.
2. Check the keypad-initiated alarms, if programmed in field *05, by pressing the Panic key pairs [*] & [#], [1] & [*], and/or [3] & [#] or dedicated panic keys A, B, and C, if present.

If the system has been programmed for audible emergency, the console will emit a loud, steady alarm sound. The word ALARM and a descriptor "99" will be displayed for [*] and [#] (or key B), "95" for [1] and [*] (or key A), "96" for [3] and [#] (or key C).

Silence the alarm by entering the security code and pressing OFF. If the system has been programmed for silent panic, there will be no audible alarms or displays. A report will be sent to the central station, however.

3. Notify the central station that all tests are finished and verify results with them.

Turning The System Over To The User

1. Fully explain the operation of the system to the user by going over each of its functions as well as the User's Manual supplied.
2. In particular, explain the operation of each zone (entry/exit, perimeter, interior, fire, etc.). Be sure the user understands how to operate any emergency feature(s) programmed into the system.

Important!:

In the spaces provided in the User's Manual, record the Entry and Exit Delay times, and those functions that have been programmed into the PANIC keys:

Key pairs [*] & [#], [1] & [*], [3] & [#], or,
individual keys, A, B, and C.

3. Make sure the user understands the importance of testing the system at least weekly, following the procedure provided in the User's Manual.

TO THE INSTALLER

Regular maintenance and inspection (at least annually) by the installer and frequent testing by the user are vital to continuous satisfactory operation of any alarm system.

The installer should assume the responsibility of developing and offering a regular maintenance program to the user as well as acquainting the user with the proper operation and limitations of the alarm system and its component parts. Recommendations must be included for a specific program of frequent testing (at least weekly) to insure the system's proper operation at all times.

Section 11. TROUBLESHOOTING

Remote Consoles

Console Is Inoperable; Erratic Display

- Power down completely (AC + battery), disconnect the battery, and power up again (AC only).
- Check that auxiliary voltage is between 12.5VDC-14.0VDC. If not, disconnect all auxiliary devices, and take another reading. If now within the above range, there was too much current being drawn by the auxiliary devices. (see the Auxiliary Device Worksheet for the current draw of each device). If still not within the above range, check incoming power from the No. 1361 transformer. Voltage should be 16.5VAC. If below 15VAC, carefully check the AC supply for a minimum of 110 VAC.
- With all auxiliary devices and battery still disconnected, check the voltage on the red & black battery leads. It should be 13.65VDC (approx.). If not, replace the Control. If it is @ 13.65VDC, the battery may not be at full charge (allow the battery to charge 12-24 hours before reconnecting the auxiliary devices) or the battery may be bad, and not able to hold a charge.

Hard-Wired Zones, 1-8

Zone 1 in trouble ("CHECK" or "FAULT")

- If zone 1 is programmed for fire (response type 9), make sure that field 1*46 is set to "3" (zone 1 EOLR). Also, make sure that the RED jumper is intact and that there is a 2,000 ohm EOLR across the last device, as described in the SYSTEM CONFIGURATION: ZONES section. All devices must be normally open and connected in parallel across terminals 9 and 10.
- If zone 1 is programmed as a non-fire response type and field *41 is programmed as a "0" (EOLR required), make sure that the RED jumper is intact and that there is a 2000 ohm EOLR connected across the last device, as described in the SYSTEM CONFIGURATION: ZONES section. All devices must be normally open and connected in parallel across terminals 9 and 10. Check that field 1*46 is set to "3" (zone 1 EOLR).
- If zone 1 is programmed as a non-fire response type and field *41 is programmed as a "1" (normal closed loops), make sure that the RED jumper is cut, and that normally closed devices are connected in series between terminals 10 and 12 as described in the SYSTEM CONFIGURATION: ZONES section.

Zones 2-8 not detecting faults when their EOLRs are shorted (READY display stays on)

- If using EOLRs, check that program field *41=0; if not using EOLRs, *41=1.

Zones 1-8 is not detecting faults (READY light stays on)

- Check program fields 1*18 and 1*19 to make sure the wired zone(s) in question have not been enabled as RF zones.

Hard-Wired Zones On 4219 Wired Zone Expander

Zones on 4219 not detecting faults

- Make sure that RF zones do not overlap any of the 4219 zones.
- Make sure that Address 1*58 is programmed correctly and that the correct response types have been entered for the corresponding zones.
- Make sure that the dipswitches on the 4219 are set in accordance with Figure 1 in the section titled WIRED ZONE EXPANSION.

"81" appears in the console display and rapid beeping occurs.

- The 4219 wired zone expander is not responding to the control panel.
- Check that the control is wired properly to the 4219.
- Check that the wire run length is in agreement with the recommended wire gauge.
- Make sure that the dipswitches on the 4219 are set in accordance with Figure 1 in the section titled WIRED ZONE EXPANSION.

Wireless

"SET-UP ERROR" (Alpha consoles), "E4" or "E8" Fixed-Word consoles) displayed

More than the allowed RF zones have been enabled in fields 1*18–1*25 (see below).

<i>Console Type</i>	<i>RF Receiver Type</i>	<i>Error Message</i>
Alpha	4281L (4 zones)	"SET-UP ERROR"
Alpha	4281H/M (8 zones)	"SET-UP ERROR"
Fixed-Word	4281L (4 zones)	"E4"
Fixed-Word	4281H/M (8 zones)	"E8"

"88" or "90" appears in console display and rapid beeping occurs

- The 4281 receiver is not receiving any signals from any of the transmitters in the system. An "88" is for the 2nd receiver; a "90" is for the 1st receiver. These displays are enabled by assigning a zone response type in program fields 1*08, and 1*09. The recommended response is either zone type 05 or 07.
- Check that the antenna is installed properly and is not shorted to any metal object, refer to WIRELESS EXPANSION section for details.
- Check that the transmitters are powered up with fresh 9 volt batteries.
- Check that the house ID's match between transmitters and the entry in field 1*51.
- Determine if anything is blocking transmission to the receiver (ex: metal cabinets or shelves, etc.)
- Put the system in the test mode, then see if the transmitters check-in. If not, move the 4281 receiver to another location and test again.

"89" or "91" appears in console display and rapid beeping occurs

- The 4281 receiver is not responding to the Control panel. An "89" refers to the second receiver and a "91" refers to the first receiver.
- Check that the control is wired properly to the receiver.
- Check that the dipswitches for each 4281 receiver are set in accordance with Figure 2 in the WIRELESS ZONE EXPANSION section.
- Check that the wire run length is in agreement with the recommended wire gauge.

Zones, not programmed in the system, are indicating "CHECK" conditions

- Check program fields *02 through *05, and 1*01 through 1*05 to make sure all unused zones are 00s.
- Check program fields 1*18 through 1*25 to make sure that all non-RF zones are 0s.

Zones indicating a "NOT READY" condition, but transmitter contact loop is intact

- Put the system in the SNIFFER MODE for at least 2 hours, to see if another system in the area is using the same house ID. If so, change this system's house ID number.
- Make sure zones in question are selected as RF in fields 1*18-1*25.

One or more transmitters are indicating "CHECK" conditions after a while; console beeping rapidly:

- Check that the transmitters have the correct house ID programmed.
- Check that the transmitters have the correct transmitter ID assigned.
- Check that the transmitters have fresh batteries.

"READY" display not going out when RF zones faulted

- Check that the house ID's match between the transmitters and the receiver.
- Check that the receiver is enabled in program fields 1*26 for the first receiver and 1*27 for the second receiver.
- Check that the zones in question are enabled for RF in program fields 1*18 through 1*25.
- Check that a zone response is programmed for the zones in question, in fields *02 through *05, and 1*01 through 1*05.
- Check that the receiver's antenna is properly installed.
- Remove any sensors from the transmitters and short across the transmitter terminals. Then fault the transmitter to see if the "READY" light goes out. If it does not go out, check the programming for that particular transmitter; if it does go out, check the sensors on that zone.
- Move the receiver to another location for better reception.

Console displays "NOT READY" but no zone is displayed when [*] READY key is depressed

- A Silent Panic condition may be present. Key the security code + OFF to see if the condition clears.

While in the "TEST" mode, some or all of the transmitters are not responding, or are responding irregularly

- The Test mode cuts the receiver's sensitivity by 50%. This means that as long as a transmitter responds, its location is satisfactory.
- Move the affected transmitters to another location and re-test. There may be something blocking its transmission path.
- If all transmitters are affected, move the receiver to another location. There may be something blocking its reception.
- If no receiver location can be found that can reliably receive *all* transmitters, add a second receiver in a different location in the premises to extend the RF coverage of the system.

Communications

"FC" or "COMM FAILURE", is displayed

- "FC" (Fixed-word consoles) or "COMM FAILURE" (Alpha consoles) indicates that the communicator has attempted 8 times to send a report to the central station but did not get kiss-off.
- If backup reporting is enabled, as many as 16 attempts may be made before obtaining the "FC" error.
- Check with the central station to make sure the programmed format is acceptable to the central station's receiver.
- Check program field *49 to see if single message with checksum has been enabled. The central station receiver might not be able to handle checksum.
- Check program field 1*34 to see if split reporting is enabled. If only a primary central station phone number is being used, field 1*34 must = 0!
- Check program field *31, PABX ACCESS CODE. Enter up to 4-digits only if an outside line must be accessed before the number is dialed or if "call waiting" is to be suppressed. The latter feature must be obtained from the local telephone company. To make sure this field is empty, key *31* to erase this location.
- Check program field *30 for either TouchTone or rotary dialing. In most cases, if rotary is selected dialing will be successful, but if TouchTone is selected, then the line must be a TouchTone line. It is possible that a line that had permitted TouchTone service previously was now being blocked from that use by the telephone company because the user was not paying for that service. At installation time, it is important to check with the user to determine if they are paying for TouchTone service.
- If SESCOA/RADIONICS format is being used, check program field *50. If hexadecimal codes are being sent, enter a "0". If only 0-9 is being sent, either a "1" or a "0" is acceptable. Check with the central station to verify acceptance of B-F codes.
- If 3+1/4+1 LOW SPEED is being used, check the ID portion of the report code fields. There should be "0" in all of these fields. Some central station receivers cannot handle second digit reporting.
- Check the telephone numbers programmed in fields *33 & *34.
- Listen to the outgoing call attempts using a handset.
- Check the wiring on the Telco connector.

IN THE EVENT OF TELEPHONE OPERATIONAL PROBLEMS

In the event of telephone operational problems, disconnect the control panel by removing the plug from the RJ31X (CA38A in Canada) wall jack. We recommend that you demonstrate disconnecting the phones on installation of the system. Do not disconnect the phone connection inside the Control Panel. Doing so will result in the loss of your phone lines. If the regular phone works correctly after the Control Panel has been disconnected from the phone lines, the Control Panel has a problem and should be returned for repair. If upon disconnection of the Control Panel, there is still a problem on the line, notify the telephone company that they have a problem and request prompt repair service. The user may not under any circumstances (in or out of warranty) attempt any service or repairs to the system. It must be returned to the factory or an authorized service agency for all repairs.

Section 12. SPECIFICATIONS

4120XM CONTROL

Physical: 12-1/2"W X 14-1/2"H X 3"D
(317mm x 368mm x 76mm)

Electrical:

Voltage Input: From Ademco No. 1321/TF2 Plug-In Transformer (use 1321CN in Canada) rated 16.5VAC, 25 VA.

Alarm Sounder Output: 10VDC-13.8VDC, 2.8 amps max. (non-UL installations). See UL note below.

Aux. Power Output: 9.6VDC-13.8VDC, 700mA max (700 mA less Aux current draw for UL installations). For UL installations, the accessories connected to the output must be UL Listed, and rated to operate in the above voltage range.

UL NOTE: The current draw from the Aux Output and Alarm Output *combined* must not exceed 700 mA in UL installations.

Back-up Battery: 12VDC, 4AH or 7AH gel cell. YUASA NP4-12 (12V, 4AH) or NP7-12 (12V, 7AH) recommended. Use 4AH battery for UL installations.

Standby: 4 hours min. with 500 mA aux. load using 4AH battery.

Circuit Protectors: Thermal circuit breakers are used on battery input to protect against reverse battery connections and on alarm sounder output to protect against wiring faults (shorts) and on auxiliary power output to protect against wiring faults (shorts).

DIGITAL COMMUNICATOR

Formats Supported:

ADEMCO HIGH SPEED
ADEMCO 4+2 EXPRESS
ADEMCO LOW SPEED
ADEMCO CONTACT ID
SESCOA
RADIONICS LOW SPEED

LINE SEIZE: Double Pole

RINGER EQUIVALENCE: 0.7B

FCC REGISTRATION NO.: AC398U-68192-AL-E

4127 REMOTE CONSOLE

Physical: 5-5/8"W X 4-11/16"H X 7/8"D
(143mm x 119mm x 22mm)

Electrical: Voltage Input: 12VDC
Current Drain: 20 mA

Interface Wiring:

RED: 12VDC input (+) - auxiliary power

GREEN: Data to control panel

YELLOW: Data from control panel

BLACK: Ground and (-) connection from supplemental power supply.

4137AD/5137AD REMOTE CONSOLES

Physical: 8.4" W x 4.75" H x 1.1" D
(213mm x 121mm x 28mm)

Electrical: Voltage Input: 12VDC
Current Drain: 60 mA (4137AD)
90 mA (5137AD)

Interface Wiring:

RED: 12VDC input (+) auxiliary power

BLUE: (if present) Not Used

GREEN: Data to control panel

YELLOW: Data from control panel

BLACK: Ground and (-) connection from supplemental power supply.

- 6127 REMOTE CONSOLE** **Physical:** 5.75" W x 4.75" H x 1" D
(146mm x 121mm x 26mm)
- Electrical:** Voltage Input: 12VDC
Current Drain: 20 mA
- Interface Wiring:**
 RED: 12VDC input (+) auxiliary power
 BLUE: (If present) Not Used
 GREEN: Data to control panel
 YELLOW: Data from control panel
 BLACK: Ground and (-) connection from supplemental power supply.
-
- 6137 REMOTE CONSOLE** **Physical:** 6.25" W x 4.75"H x 1" D
(159mm x 121mm x 26mm)
- Electrical:** Voltage Input: 12VDC
Current Drain: 85 mA
- Interface Wiring:**
 RED: 12VDC input (+) auxiliary power
 BLUE: (If present) Not Used
 GREEN: Data to control panel
 YELLOW: Data from control panel
 BLACK: Ground and (-) connection from supplemental power supply.
-
- 6139 REMOTE CONSOLE** **Physical:** 6.25" W x 4.75"H x 1.25" D
(159mm x 121mm x 32mm)
- Electrical:** Voltage Input: 12VDC
Current Drain: 100 mA
- Interface Wiring:**
 RED: 12VDC input (+) auxiliary power
 BLUE: (If present) Not Used
 GREEN: Data to control panel
 YELLOW: Data from control panel
 BLACK: Ground and (-) connection from supplemental power supply.

IMPORTANT
 BATTERY NORMALLY NEED NOT BE REPLACED FOR AT LEAST 3 YEARS.
 GEL LEAD ACID TYPE, DO NOT USE GATES BATTERY. WHEN POWERING UP THE UNIT, FIRST PLUG IN THE TRANSFORMER, THEN CONNECT THE BATTERY.

ALARM OUTPUT
 10.0-13.8VDC, 2.8A MAX**
 (SEE UL NOTE)
 USE UL RESIDENTIAL FIRE LISTED SOUNDER FOR UL INSTALLATION:
 ADEMCO Nos. 719 OR 702 SIREN OR AMSECO ABB-1031 MOTOR BELL FOR NON-UL USAGE.
 **ASSUMES A FULLY CHARGED BATTERY IS CONNECTED

UL NOTE:
 COMBINED ALARM AND AUX POWER OUTPUT MUST BE LIMITED TO 700mA FOR UL INSTALLATIONS.

***SEE "TRIGGER OUTPUTS" SECTION IN INSTALLATION INSTRUCTIONS FOR COMPLETE INFORMATION REGARDING REQUIRED PROGRAMMING (ALSO SEE FIELDS '15 & '15').**
 † USE SA4120XM-2 OR SA4120XP-2 CABLES.

WARNING: OWNER'S INSTRUCTION NOTICE NOT TO BE REMOVED

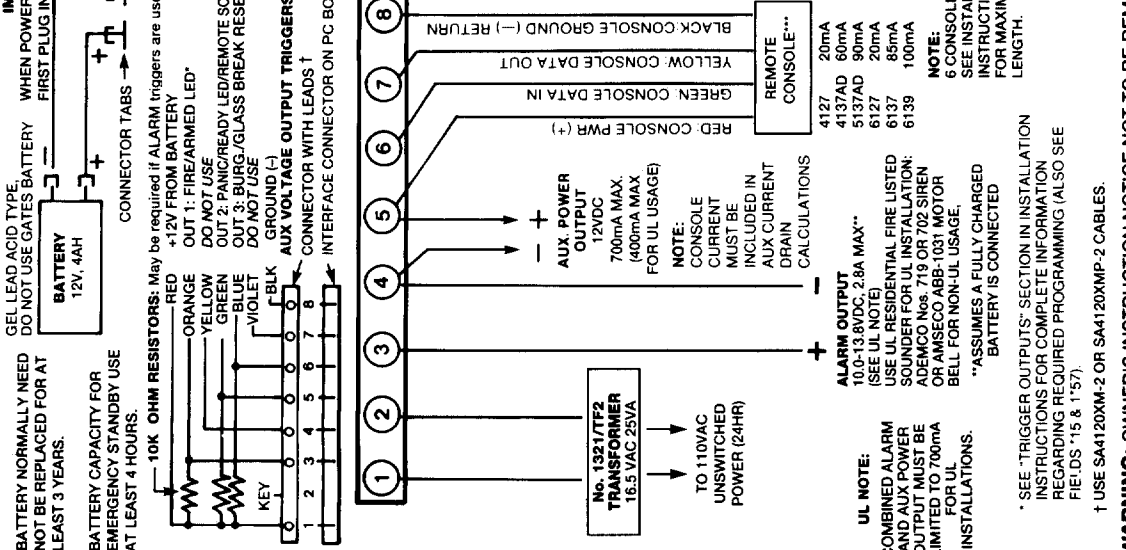
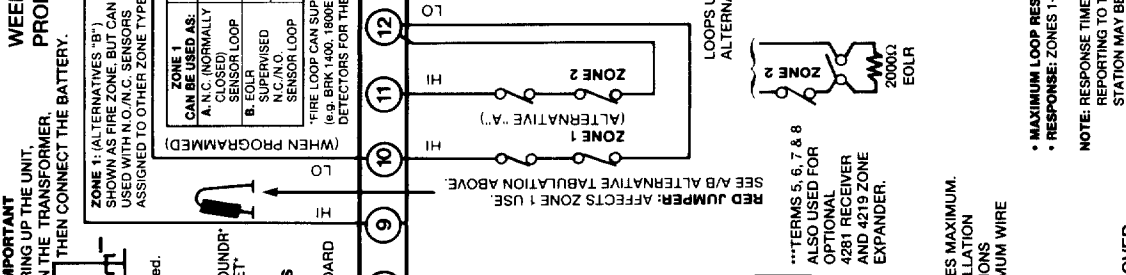
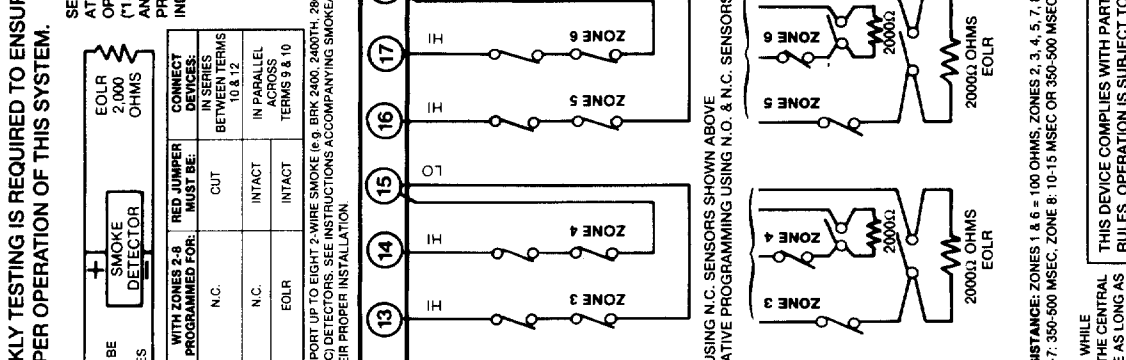
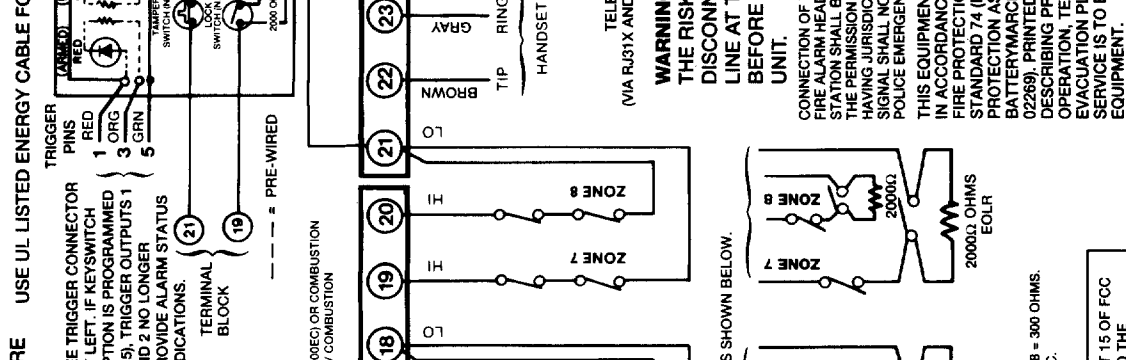

NOTE: RESPONSE TIME WHILE REPORTING TO THE CENTRAL STATION MAY BE AS LONG AS 1 SECOND.

***MAXIMUM LOOP RESISTANCE: ZONES 1 & 6 = 100 OHMS, ZONES 2, 3, 4, 5, 7, 8 = 300 OHMS.
 *RESPONSE: ZONES 1-7: 350-500 MSEC. ZONE 8: 10-15 MSEC OR 350-500 MSEC.**

THIS DEVICE COMPLIES WITH PART 15 OF FCC RULES. OPERATION IS SUBJECT TO THE FOLLOWING TWO CONDITIONS:
 1) IT MAY NOT CAUSE HARMFUL INTERFERENCE THAT MAY CAUSE UNDESIRABLE OPERATION.
 2) IT MUST ACCEPT ANY INTERFERENCE THAT MAY CAUSE UNDESIRABLE OPERATION.

Figure 9. 4120XM SUMMARY OF CONNECTIONS DIAGRAM

FEDERAL COMMUNICATIONS COMMISSION (FCC) PART 15 STATEMENT

This equipment has been tested to FCC requirements and has been found acceptable for use. The FCC requires the following statement for your information:

This equipment generates and uses radio frequency energy and if not installed and used properly, that is, in strict accordance with the manufacturer's instructions, may cause interference to radio and television reception. It has been type tested and found to comply with the limits for a Class B computing device in accordance with the specifications in Subpart J of Part 15 of FCC Rules, which are designed to provide reasonable protection against such interference in a residential installation. However, there is no guarantee that interference will not occur in a particular installation. If this equipment does cause interference to radio or television reception, which can be determined by turning the equipment off and on, the user is encouraged to try to correct the interference by one or more of the following measures:

- If using an indoor antenna, have a quality outdoor antenna installed.
- Reorient the receiving antenna until interference is reduced or eliminated.
- Move the receiver away from the security control.
- Move the antenna leads away from any wire runs to the security control
- Plug the security control into a different outlet so that it and the receiver are on different branch circuits.

If necessary, the user should consult the dealer or an experienced radio/television technician for additional suggestions.

The user or installer may find a booklet titled "Interference Handbook" prepared by the Federal Communications Commission helpful. This booklet is available from the U.S. Government Printing Office, Washington, DC 20402.

The user shall not make any changes or modifications to the equipment unless authorized by the Installation Instructions or User's Manual. Unauthorized changes or modifications could void the user's authority to operate the equipment.

FEDERAL COMMUNICATIONS COMMISSION (FCC) PART 68 STATEMENT

This equipment complies with Part 68 of the FCC rules. On the front cover of this equipment is a label that contains, among other information, the FCC registration number and ringer equivalence number (REN) for this equipment. If requested, this information must be provided to the telephone company.

This equipment uses the following jacks:

An RJ31X is used to connect this equipment to the telephone network.

The REN is used to determine the quantity of devices which may be connected to the telephone line. Excessive RENs on the telephone line may result in the devices not ringing in response to an incoming call. In most, but not all areas, the sum of the RENs should not exceed five (5.0). To be certain of the number of devices that may be connected to the line, as determined by the total RENs, contact the telephone company to determine the maximum REN for the calling area.

If this equipment causes harm to the telephone network, the telephone company will notify you in advance that temporary discontinuance of service may be required. If advance notice is not practical, the telephone company will notify the customer as soon as possible. Also, you will be advised of your right to file a complaint with the FCC if you believe necessary.

The telephone company may make changes in its facilities, equipment, operations, or procedures that could affect the operation of the equipment. If this happens, the telephone company will provide advance notice in order for you to make the necessary modifications in order to maintain uninterrupted service.

If trouble is experienced with this equipment, please contact the manufacturer for repair and warranty information. If the trouble is causing harm to the telephone network, the telephone company may request you remove the equipment from the network until the problem is resolved.

There are no user serviceable components in this product, and all necessary repairs must be made by the manufacturer. Other repair methods may invalidate the FCC registration on this product.

This equipment cannot be used on telephone company-provided coin service. Connection to Party Line Service is subject to state tariffs.

This equipment is hearing-aid compatible.

When programming or making test calls to emergency numbers, briefly explain to the dispatcher the reason for the call. Perform such activities in the off-peak hours; such as early morning or late evening.

CANADIAN DEPARTMENT OF COMMUNICATIONS (DOC) STATEMENT

NOTICE

The Canadian Department of Communications label identifies certified equipment. This certification means that the equipment meets certain telecommunications network protective, operational and safety requirements. The Department does not guarantee the equipment will operate to the user's satisfaction.

Before installing this equipment, users should ensure that it is permissible to be connected to the facilities of the local telecommunications company. The equipment must also be installed using an acceptable method of connection. In some cases, the company's inside wiring associated with a single line individual service may be extended by means of certified connector assembly (telephone extension cord). The customer should be aware that compliance with the above conditions may not prevent degradation of service in some situations.

Repairs to certified equipment should be made by an authorized Canadian maintenance facility designated by the supplier. Any repairs or alterations made by the user to this equipment, or equipment malfunctions, may give the telecommunications company cause to request the user to disconnect the equipment.

Users should ensure for their own protection that the electrical ground connections of the power utility, telephone lines and internal metallic water pipe system, if present, are connected together. This precaution may be particularly important in rural areas.

Caution: User should not attempt to make such connections themselves, but should contact the appropriate electric inspection authority, or electrician, as appropriate.

The Load Number (LN) assigned to each terminal device denotes the percentage of the total load to be connected to a telephone loop which is used by the device, to prevent overloading. The termination on a loop may consist of any combination of devices subject only to the requirement that the total of the Load Numbers of all the devices does not exceed 100.

AVIS

L'étiquette du ministère des Communications du Canada identifie le matériel homologué. Cette étiquette certifie que le matériel est conforme à certaines normes de protection, d'exploitation et de sécurité des réseaux de télécommunications. Le ministère n'assure toutefois pas que le matériel fonctionnera à la satisfaction de l'utilisateur.

Avant d'installer ce matériel, l'utilisateur doit s'assurer qu'il est permis de le raccorder aux installations de l'entreprise locale de télécommunication. Le matériel doit également être installé en suivant une méthode acceptée de raccordement. Dans certains cas, les fils intérieurs de l'entreprise utilisés pour un service individuel à ligne unique peuvent être prolongés au moyen d'un dispositif homologué de raccordement (cordon prolongateur téléphonique interne). L'abonné ne doit pas oublier qu'il est possible que la conformité aux conditions énoncées ci-dessus n'empêchent pas la dégradation du service par certaines situations. Actuellement, les entreprises de télécommunication ne permettent pas que l'on raccorde leur matériel aux jacks d'abonnés, sauf dans les cas précis prévus par les tarifs particuliers de ces entreprises.

Les réparations de matériel homologué doivent être effectuées par un centre d'entretien canadien autorisé désigné par le fournisseur. La compagnie de télécommunications peut demander à l'utilisateur de débrancher un appareil à la suite de réparations ou de modifications effectuées par l'utilisateur ou à cause de mauvais fonctionnement.

Pour sa propre protection, l'utilisateur doit s'assurer que tous les fils de mise à la terre de la source d'énergie électrique, des lignes téléphoniques et des canalisations d'eau métalliques, s'il y en a, sont raccordés ensemble. Cette précaution est particulièrement importante dans les régions rurales.

Avertissement: L'utilisateur ne doit pas tenter de faire ces raccordements lui-même; il doit avoir recours à un service d'inspection des installations électriques, ou à un électricien, selon le cas.

L'indice de charge (IC) assigné à chaque dispositif terminal pour éviter toute surcharge indique le pourcentage de la charge totale qui peut être raccorderé à un circuit téléphonique bouclé utilisé par ce dispositif. La terminaison du circuit bouclé peut être constituée de n'importe quelle combinaison de dispositifs, pourvu que la somme des indices de charge de l'ensemble des dispositifs ne dépasse pas 100.

WARNING

THE LIMITATIONS OF THIS ALARM SYSTEM

While this System is an advanced wireless security system, it does not offer guaranteed protection against burglary, fire or other emergency. Any alarm system, whether commercial or residential, is subject to compromise or failure to warn for a variety of reasons. For example:

- Intruders may gain access through unprotected openings or have the technical sophistication to bypass an alarm sensor or disconnect an alarm warning device.
- Intrusion detectors (e.g., passive infrared detectors), smoke detectors, and many other sensing devices will not work without power. Battery-operated devices will not work without batteries, with dead batteries, or if the batteries are not put in properly. Devices powered solely by AC will not work if their AC power supply is cut off for any reason, however briefly.
- Signals sent by wireless transmitters (used in some systems) may be blocked or reflected by metal before they reach the alarm receiver. Even if the signal path has been recently checked during a weekly test, blockage can occur if a metal object is moved into the path.
- A user may not be able to reach a panic or emergency button quickly enough.
- While smoke detectors have played a key role in reducing residential fire deaths in the United States, they may not activate or provide early warning for a variety of reasons in as many as 35% of all fires, according to data published by the Federal Emergency Management Agency. Some of the reasons smoke detectors used in conjunction with this System may not work are as follows. Smoke detectors may have been improperly installed and positioned. Smoke detectors may not sense fires that start where smoke cannot reach the detectors, such as in chimneys, in walls, or roofs, or on the other side of closed doors. Smoke detectors also may not sense a fire on another level of a residence or building. A second floor detector, for example, may not sense a first floor or basement fire. Finally, smoke detectors have sensing limitations. No smoke detector can sense every kind of fire every time. In general, detectors may not always warn about fires caused by carelessness and safety hazards like smoking in bed, violent explosions, escaping gas, improper storage of flammable materials, overloaded electrical circuits, children playing with matches, or arson. Depending on the nature of the fire and/or location of the smoke detectors, the detector, even if it operates as anticipated, may not provide sufficient warning to allow all occupants to escape in time to prevent injury or death.
- Passive Infrared Motion Detectors can only detect intrusion within the designed ranges as diagrammed in their installation manual. Passive Infrared Detectors do not provide volumetric area protection. They do create multiple beams of protection, and intrusion can only be detected in unobstructed areas covered by those beams. They cannot detect motion or intrusion that takes place behind walls, ceilings, floors, closed doors, glass partitions, glass doors, or windows. Mechanical tampering, masking, painting or spraying of any material on the mirrors, windows or any part of the optical system can reduce their detection ability. Passive Infrared Detectors sense changes in temperature; however, as the ambient temperature of the protected area approaches the temperature range of 90° to 105°F (32° to 40°C), the detection performance can decrease.
- Alarm warning devices such as sirens, bells or horns may not alert people or wake up sleepers if they are located on the other side of closed or partly open doors. If warning devices are located on a different level of the residence from the bedrooms, then they are less likely to waken or alert people inside the bedrooms. Even persons who are awake may not hear the warning if the alarm is muffled by noise from a stereo, radio, air conditioner or other appliance, or by passing traffic. Finally, alarm warning devices, however loud, may not warn hearing-impaired people.
- Telephone lines needed to transmit alarm signals from a premises to a central monitoring station may be out of service or temporarily out of service. Telephone lines are also subject to compromise by sophisticated intruders.
- Even if the system responds to the emergency as intended, however, occupants may have insufficient time to protect themselves from the emergency situation. In the case of a monitored alarm system, authorities may not respond appropriately.
- This equipment, like other electrical devices, is subject to component failure. Even though this equipment is designed to last as long as 20 years, the electronic components could fail at any time.

The most common cause of an alarm system not functioning when an intrusion or fire occurs is inadequate maintenance. This alarm system should be tested weekly to make sure all sensors and transmitters are working properly. The security console (and remote keypad) should be tested as well.

Wireless transmitters (used in some systems) are designed to provide long battery life under normal operating conditions. Longevity of batteries may be as much as 4 to 7 years, depending on the environment, usage, and the specific wireless device being used. External factors such as humidity, high or low temperatures, as well as large swings in temperature, may all reduce the actual battery life in a given installation. This wireless system, however, can identify a true low battery situation, thus allowing time to arrange a change of battery to maintain protection for that given point within the system.

Installing an alarm system may make the owner eligible for a lower insurance rate, but an alarm system is not a substitute for insurance. Homeowners, property owners and renters should continue to act prudently in protecting themselves and continue to insure their lives and property.

We continue to develop new and improved protection devices. Users of alarm systems owe it to themselves and their loved ones to learn about these developments.

ADEMCO LIMITED WARRANTY

Alarm Device Manufacturing Company, a Division of Pittway Corporation, and its divisions, subsidiaries and affiliates ("Seller"), 165 Eileen Way, Syosset, New York 11791, warrants its products to be in conformance with its own plans and specifications and to be free from defects in materials and workmanship under normal use and service for 18 months from the date stamp control on the product or, for products not having an Ademco date stamp, for 12 months from date of original purchase unless the installation instructions or catalog sets forth a shorter period, in which case the shorter period shall apply. Seller's obligation shall be limited to repairing or replacing, at its option, free of charge for materials or labor, any product which is proved not in compliance with Seller's specifications or proves defective in materials or workmanship under normal use and service. Seller shall have no obligation under this Limited Warranty or otherwise if the product is altered or improperly repaired or serviced by anyone other than Ademco factory service. For warranty service, return product transportation prepaid, to Ademco Factory Service, 165 Eileen Way, Syosset, New York 11791.

THERE ARE NO WARRANTIES, EXPRESS OR IMPLIED, OF MERCHANTABILITY, OR FITNESS FOR A PARTICULAR PURPOSE OR OTHERWISE, WHICH EXTEND BEYOND THE DESCRIPTION ON THE FACE HEREOF. IN NO CASE SHALL SELLER BE LIABLE TO ANYONE FOR ANY CONSEQUENTIAL OR INCIDENTAL DAMAGES FOR BREACH OF THIS OR ANY OTHER WARRANTY, EXPRESS OR IMPLIED, OR UPON ANY OTHER BASIS OF LIABILITY WHATSOEVER, EVEN IF THE LOSS OR DAMAGE IS CAUSED BY THE SELLER'S OWN NEGLIGENCE OR FAULT.

Seller does not represent that the products it sells may not be compromised or circumvented; that the products will prevent any personal injury or property loss by burglary, robbery, fire or otherwise; or that the products will in all cases provide adequate warning or protection. Customer understands that a properly installed and maintained alarm may only reduce the risk of a burglary, robbery, fire or other events occurring without providing an alarm, but it is not insurance or a guarantee that such will not occur or that there will be no personal injury or property loss as a result. CONSEQUENTLY, SELLER SHALL HAVE NO LIABILITY FOR ANY PERSONAL INJURY, PROPERTY DAMAGE OR OTHER LOSS BASED ON A CLAIM THE PRODUCT FAILED TO GIVE WARNING. HOWEVER, IF SELLER IS HELD LIABLE, WHETHER DIRECTLY OR INDIRECTLY, FOR ANY LOSS OR DAMAGE ARISING UNDER THIS LIMITED WARRANTY OR OTHERWISE, REGARDLESS OF CAUSE OR ORIGIN, SELLER'S MAXIMUM LIABILITY SHALL NOT IN ANY CASE EXCEED THE PURCHASE PRICE OF THE PRODUCT, WHICH SHALL BE THE COMPLETE AND EXCLUSIVE REMEDY AGAINST SELLER. This warranty replaces any previous warranties and is the only warranty made by Seller on this product. No increase or alteration, written or verbal, of the obligations of this Limited Warranty is authorized.



ALARM DEVICE MANUFACTURING CO.

A DIVISION OF PITTMAY CORPORATION

165 Eileen Way, Syosset, New York 11791

Copyright © 1993 PITTMAY CORPORATION

4120XM PROGRAMMING FORM

SUMMARY OF PROGRAMMING COMMANDS

- To enter program mode, enter installer code + [8] + [0] + [0]. Enter first field address to begin programming.
- To set standard defaults, press *97
- To set communication defaults, press *94 + one of the following: *80=low speed; *81=Ademco Express; *82=Ademco High Speed; *83=Ademco's Contact ID
- To change to 2nd page of program fields, press *94
- To return to 1st page of fields, press *99
- To erase account & phone number field entries, press [*] + field number + [*]
- To assign zone descriptors, press *93 + zone number
- To add custom words, press *93 + 00 + word number (1-20)
- To enter Installer's Message, press *93 + 00 + 00
- To exit program mode, press *99 OR *98: *99 allows re-access to programming mode by installer code. *98 prevents re-access to programming mode by installer code.
- Default values are shown in brackets []; otherwise default = 0

***00 INSTALLER CODE**

Enter 4 digits, 0-9 [4120]

***01 MASTER SECURITY CODE**

Enter 4 digits, 0-9 [1234] See 1*54 for 6-digit enable

ASSIGN RESPONSE TYPE FOR ZONES

(Enter 00-10; see Response Types table below)
 Hard-Wire zones = 1-8; Wireless zones = 1-63 plus
 RF Receiver zones 88-91

*02	*03	*04	*05	
1 <input type="text" value=" "/>	9 <input type="text" value=" "/>	17 <input type="text" value=" "/>	25 <input type="text" value=" "/>	
2 <input type="text" value=" "/>	10 <input type="text" value=" "/>	18 <input type="text" value=" "/>	26 <input type="text" value=" "/>	
3 <input type="text" value=" "/>	11 <input type="text" value=" "/>	19 <input type="text" value=" "/>	27 <input type="text" value=" "/>	
4 <input type="text" value=" "/>	12 <input type="text" value=" "/>	20 <input type="text" value=" "/>	010	Not Used
5 <input type="text" value=" "/>	13 <input type="text" value=" "/>	21 <input type="text" value=" "/>	010	Not Used
6 <input type="text" value=" "/>	14 <input type="text" value=" "/>	22 <input type="text" value=" "/>	95 <input type="text" value=" "/>	(1+*/A)
7 <input type="text" value=" "/>	15 <input type="text" value=" "/>	23 <input type="text" value=" "/>	96 <input type="text" value=" "/>	(3+ #C)
8 <input type="text" value=" "/>	16 <input type="text" value=" "/>	24 <input type="text" value=" "/>	99 <input type="text" value=" "/>	(#+ #B)

00 = Assign for unused zones	06 = 24-HOUR SILENT
01 = ENTRY/EXIT #1	07 = 24-HOUR AUDIBLE
02 = ENTRY/EXIT #2	08 = 24-HOUR AUXILIARY
03 = PERIMETER	09 = FIRE
04 = INTERIOR, FOLLOWER	10 = INTERIOR, DELAY
05 = DAY/NIGHT	

***09 ENTRY DELAY #1** [02] (00-15 times 15 seconds)

***10 EXIT DELAY #1** [03] (00-15 times 15 seconds)

***11 ENTRY DELAY #2** [06] (00-15 times 15 seconds)

***12 EXIT DELAY #2** [08] (00-15 times 15 seconds)

***13 ALARM SOUNDER DURATION**
 01-15 times 2 minutes [04]. Minimum 4 minutes for UL.

***14 ZONE 8 FAST/SLOW RESPONSE** [0=slow; 1=fast]

***15 KEYSWITCH ENABLE** [0=disable; 1=enable]
 (ALSO SEE ADDRESS 1*57, TRIGGER MODE)
 Note: If keyswitch is enabled, you must enter "0" in field *41

***16 CONFIRMATION OF ARMING DING**
 1=enable; [0=disable]

***17 AC POWER LOSS SOUNDING** 1=yes; [0=no]

***18 AC POWER LOSS ALARM** 1=yes; [0=no]

***19 AC RANDOMIZE** 1=randomize 10-40 min.; [0=no]

***21 DISABLE FIRE TIME-OUT** 1=no timeout; [0=fire timeout]

***23 MULTIPLE ALARMS** [1=yes; 0=no]

***25 BURGLAR TRIGGER FOR ZONE RESP. TYPE 8**
 [0=disable; 1=enable]

***26 INTELLIGENT TEST REPORTING** Set "0" for UL
 1=yes, (no report sent if any other report was recently sent); [0=no]

***27 TEST REPORT INTERVAL**
 Enter interval in hours, 001-199; 000=no report [024]; Max. 024 for UL.

***28 POWER UP IN PREVIOUS STATE**
 [1=yes; 0=no; "1" for UL]

***29 QUICK ARM** [1=yes; 0=no]

***30 TOUCH-TONE OR ROTARY DIAL**
 1=TouchTone; [0=rotary] See field 1*33 for Touch-Tone w/Rotary backup

***31 PABX ACCESS CODE**
 00-09; B-F (11-15)

***32 PRIM. SUBSCRIBER ACCT #**
 Enter 00-09; B-F (11-15) [15 15 15 15]

***33 PRIMARY PHONE NUMBER**
 Enter 0-9 for each digit

***34 SECONDARY PHONE NUMBER**
 Enter 0-9 for each digit

***35 DOWNLOAD PHONE No.**
 Enter 0-9 for each digit

***36 DOWNLOAD ID No.**
 Enter 00-09; A-F (10-15) [15 15 15 15 15 15]

***37 DOWNLOAD COMMAND ENABLES** [1=enable; 0=disable]
 See field 1*53 for Callback disable option. For UL installations, Upload & Download must be enabled. All others must be disabled.

- Dialer Shutdown
- System Shutdown
- Not Used
- Remote Bypass
- Remote Disarm
- Remote Arm
- Upload Program
- Download Program

- *38 INHIBIT BYPASS OF A ZONE |
01-31; [00 if all zones (except Fire zones) can be bypassed]
- *39 OPEN/CLOSE REPORTS FOR USERS 1-8 1=yes; 0=no

<input type="checkbox"/>	<input type="checkbox"/>	<input type="checkbox"/>	<input type="checkbox"/>	<input type="checkbox"/>	<input type="checkbox"/>	<input type="checkbox"/>	<input type="checkbox"/>
1	2	3	4	5	6	7	8
- *40 OPEN/CLOSE REPORTS FOR USERS 9-16 1=yes; 0=no

<input type="checkbox"/>	<input type="checkbox"/>	<input type="checkbox"/>	<input type="checkbox"/>	<input type="checkbox"/>	<input type="checkbox"/>	<input type="checkbox"/>	<input type="checkbox"/>
9	10	11	12	13	14	15	16

SEE FIELD 1*00 FOR USERS 17-70
- *41 EOLR DISABLE (Zones 2-8)
[1=N.C.loops]; 0=EOLR supervision; Must be "0" for UL.
Note: If keyswitch is enabled in field * 15, you must enter "0" here.
- *42 DIAL TONE PAUSE [0=5 scs; 1=11 scs; 2=30 scs; 0' for UL]
- *43 DIAL TONE DETECT [1=wait for dial tone]; 0=pause, then dial
- *44 RING DETECTION COUNT |
01-14; 15=answering machine; [00=no detection]
- *45 PRIMARY FORMAT
[0=Low Speed]; 1=Contact ID; 2=Ademco High Speed; 3=Ademco Express
- *46 LOW SPEED FORMAT (Primary)
[0=Ademco Low Speed]; 1=Sescoa/Radionics
- *47 SECONDARY FORMAT
[0=Low Speed]; 1=Contact ID; 2=Ademco High Speed; 3=Ademco Express
- *48 LOW SPEED FORMAT (Secondary.)
[0=Ademco Low Speed]; 1=Sescoa/Radionics
- *49 CHECKSUM VERIFICATION |
1=yes; [0=no] Primary Scndry
- *50 SESCOA/RADIONICS 1=Sescoa; [0=Radionics]
- *51 DUAL REPORTING
1=yes; [0=no] If used with Split Reporting "1" option (1*34), alarms go to both primary & secondary numbers, while all other reports go to secondary only. If used with Split Reporting "2" option, open/close and test messages go to both lines, while all other reports go to primary.
- *52 STANDARD/EXPANDED REPORT FOR PRIMARY

<input type="checkbox"/>	<input type="checkbox"/>	<input type="checkbox"/>	<input type="checkbox"/>	<input type="checkbox"/>	<input type="checkbox"/>
Alarm	Rstr	Bypass	Trbl	Opr/Cls	Low Bat

[0=standard]; 1=expanded; Note: Expanded overrides 4+2 format.
- *53 STANDARD/EXPANDED REPORT FOR SECONDARY

<input type="checkbox"/>	<input type="checkbox"/>	<input type="checkbox"/>	<input type="checkbox"/>	<input type="checkbox"/>	<input type="checkbox"/>
Alarm	Rstr	Bypass	Trbl	Opr/Cls	Low Bat

[0=standard]; 1=expanded; Note: Expanded overrides 4+2 format.

ALARM REPORT CODE & ID DIGITS FOR ZONES 1-32 & SUPERVISORY & RESTORE CODES
[All codes default to 00]

*54 CODE	*55 ID	*56 CODE	*57 ID	* 58	*59 CODE	*60 ID	*61 CODE	*62 ID	* 63
1	<input type="checkbox"/>	9	<input type="checkbox"/>	<input type="checkbox"/> Alarm Rst.	17	<input type="checkbox"/>	25	<input type="checkbox"/>	<input type="checkbox"/> Alarm Rst.
2	<input type="checkbox"/>	10	<input type="checkbox"/>	<input type="checkbox"/> Trouble	18	<input type="checkbox"/>	26	<input type="checkbox"/>	<input type="checkbox"/> Trouble
3	<input type="checkbox"/>	11	<input type="checkbox"/>	<input type="checkbox"/> Trble Rst.	19	<input type="checkbox"/>	27	<input type="checkbox"/>	<input type="checkbox"/> Trble Rst.
4	<input type="checkbox"/>	12	<input type="checkbox"/>	<input type="checkbox"/> Bypass	20	<input type="checkbox"/>	28	<input type="checkbox"/>	<input type="checkbox"/> Bypass
5	<input type="checkbox"/>	13	<input type="checkbox"/>	<input type="checkbox"/> Bypass Rst.	21	<input type="checkbox"/>	29	<input type="checkbox"/>	<input type="checkbox"/> Bypass Rst.
6	<input type="checkbox"/>	14	<input type="checkbox"/>		22	<input type="checkbox"/>	30	<input type="checkbox"/>	
7	<input type="checkbox"/>	15	<input type="checkbox"/>		23	<input type="checkbox"/>	31	<input type="checkbox"/>	
8	<input type="checkbox"/>	16	<input type="checkbox"/>		24	<input type="checkbox"/>	32	<input type="checkbox"/>	

ALARM REPORT CODE & ID DIGITS FOR ZONES 33-64 & SUPERVISORY & RESTORE CODES
[All codes default to 00]

*64 CODE	*65 ID	*66 CODE	*67 ID	* 68	*69 CODE	*70 ID	*71 CODE	*72 ID	* 73
33	<input type="checkbox"/>	41	<input type="checkbox"/>	<input type="checkbox"/> Alarm Rst.	49	<input type="checkbox"/>	57	<input type="checkbox"/>	<input type="checkbox"/> Alarm Rst.
34	<input type="checkbox"/>	42	<input type="checkbox"/>	<input type="checkbox"/> Trouble	50	<input type="checkbox"/>	58	<input type="checkbox"/>	<input type="checkbox"/> Trouble
35	<input type="checkbox"/>	43	<input type="checkbox"/>	<input type="checkbox"/> Trble Rst.	51	<input type="checkbox"/>	59	<input type="checkbox"/>	<input type="checkbox"/> Trble Rst.
36	<input type="checkbox"/>	44	<input type="checkbox"/>	<input type="checkbox"/> Bypass	52	<input type="checkbox"/>	60	<input type="checkbox"/>	<input type="checkbox"/> Bypass
37	<input type="checkbox"/>	45	<input type="checkbox"/>	<input type="checkbox"/> Bypass Rst.	53	<input type="checkbox"/>	61	<input type="checkbox"/>	<input type="checkbox"/> Bypass Rst.
38	<input type="checkbox"/>	46	<input type="checkbox"/>		54	<input type="checkbox"/>	62	<input type="checkbox"/>	
39	<input type="checkbox"/>	47	<input type="checkbox"/>		55	<input type="checkbox"/>	63	<input type="checkbox"/>	
40	<input type="checkbox"/>	48	<input type="checkbox"/>		56	<input type="checkbox"/>	64	<input type="checkbox"/>	

ALARM REPORT CODE & ID DIGITS FOR RF RCVRs & PANICS, & THEIR SUPV. & RESTORE CODES [All codes default to 00]

*74 CODE	*75 ID	*76 CODE	*77 ID	*78	
81 <input type="text"/>	<input type="text"/>	89 <input type="text"/>	<input type="text"/>	<input type="text"/>	Alarm Rst.
NU <input type="text"/> 010	<input type="text"/> 010	90 <input type="text"/>	<input type="text"/>	<input type="text"/>	Trouble
83 <input type="text"/>	<input type="text"/>	91 <input type="text"/>	<input type="text"/>	<input type="text"/>	Trble Rst.
NU <input type="text"/> 010	<input type="text"/> 010	Duress <input type="text"/>	<input type="text"/>	<input type="text"/>	Bypass
NU <input type="text"/> 010	<input type="text"/> 010	Not used	<input type="text"/> 010	<input type="text"/>	Bypass Rst.
NU <input type="text"/> 010	<input type="text"/> 010	95 <input type="text"/>	<input type="text"/>	<input type="text"/>	(1 + #/A)
NU <input type="text"/> 010	<input type="text"/> 010	96 <input type="text"/>	<input type="text"/>	<input type="text"/>	(3 + #/C)
88 <input type="text"/>	<input type="text"/>	99 <input type="text"/>	<input type="text"/>	<input type="text"/>	(# + #/B)

NOTES: 88 & 90 = RCVR not receiving transmitter signals.
89 & 91 = RCVR not responding, bad conn. to panel. 81=4219 Supv.;
83=4219 Tamp.

***79 ZONE TYPE RESTORE for TYPES 1-8**
1=enable; [0=disable]

<input type="text"/>	<input type="text"/>	<input type="text"/>	<input type="text"/>	<input type="text"/>	<input type="text"/>	<input type="text"/>	<input type="text"/>
1	2	3	4	5	6	7	8

***80 ZONE TYPE RESTORE for TYPES 9 & 10**
1=enable; [0=disable]

<input type="text"/>	<input type="text"/>
9	10

SYSTEM NON-ALARM CODES

	*81	*82	
	First Digit	Second Digit	
Close	<input type="text"/>	<input type="text"/>	Second digit of each
code Open	<input type="text"/>	<input type="text"/>	applies only to 4+2 or
Low Bat	<input type="text"/>	<input type="text"/>	expanded (fields *52 & *53)
Low Bat Rest	<input type="text"/>	<input type="text"/>	formats
AC Loss	<input type="text"/>	<input type="text"/>	
AC Rest	<input type="text"/>	<input type="text"/>	
Test	<input type="text"/>	<input type="text"/>	
Power	<input type="text"/>	<input type="text"/>	
Cancel	<input type="text"/>	<input type="text"/>	
Prog Tamper	<input type="text"/>	<input type="text"/>	

***83 FIRST TEST REPORT** (Hours 00-23)
00=Instant

***84 SWINGER SUPPRESSION**
01-15 alarms [15]; Must be "00" (disabled) for UL.

***87 ENTRY WARNING** [1=continuous; 0=3 beeps]

***88 BURGLAR ALARM COMM. DELAY**
1=18 seconds; [0=no delay]

***89 RESTORE REPORT TIMING**
[0=Instant, as zone restores]; 1=after bell timeout if zone restored;
2=when system is subsequently disarmed

***90 SECONDARY SUBSCRIBER ACCOUNT #**

Enter 00-09; B-F (11-15) [15 15 15 15]

1*00 OPEN/CLOSE REPORT ENABLE
 1 = Yes, [0 = No]
USER 17 18 19 20 21 22 23-70
SEE FIELDS *39 & *40 FOR USERS 1-18

ASSIGN RESPONSE TYPE FOR ZONES
(Enter 00-10; see *02-*05)

1*01	1*02	1*03	1*04	1*05
28 <input type="text"/>	33 <input type="text"/>	41 <input type="text"/>	49 <input type="text"/>	57 <input type="text"/>
29 <input type="text"/>	34 <input type="text"/>	42 <input type="text"/>	50 <input type="text"/>	58 <input type="text"/>
30 <input type="text"/>	35 <input type="text"/>	43 <input type="text"/>	51 <input type="text"/>	59 <input type="text"/>
31 <input type="text"/>	36 <input type="text"/>	44 <input type="text"/>	52 <input type="text"/>	60 <input type="text"/>
32 <input type="text"/>	37 <input type="text"/>	45 <input type="text"/>	53 <input type="text"/>	61 <input type="text"/>
	38 <input type="text"/>	46 <input type="text"/>	54 <input type="text"/>	62 <input type="text"/>
	39 <input type="text"/>	47 <input type="text"/>	55 <input type="text"/>	63 <input type="text"/>
	40 <input type="text"/>	48 <input type="text"/>	56 <input type="text"/>	64 <input type="text"/>

NO. OF NO. USED

1*08	1*09
81 <input type="text"/> 4219 NOCOM	89 <input type="text"/> 2nd RCVR
NU <input type="text"/> 010	90 <input type="text"/> 1st RCVR
83 <input type="text"/> 4219 TAMPER	91 <input type="text"/> 1st RCVR
NU <input type="text"/> 010	
NU <input type="text"/> 010	
NU <input type="text"/> 010	
88 <input type="text"/> 2nd RCVR	

For UL applications, use of 1 or 2 RF RCVRs requires enabling their respective faults (88-91) as applicable (type 5).

NOTES: 88 & 90 = RCVR not receiving transmitter signals.
89 & 91 = RCVR not responding, bad conn. to panel.

SELECTION OF WIRELESS FOR ZONES 1-63

Enter "1" to enable a zone as wireless; 0=non-wireless

1*18	<input type="text"/>	<input type="text"/>	<input type="text"/>	<input type="text"/>	<input type="text"/>	<input type="text"/>	<input type="text"/>
ZONES:	1	2	3	4	5	6	8
1*19	<input type="text"/>	<input type="text"/>	<input type="text"/>	<input type="text"/>	<input type="text"/>	<input type="text"/>	<input type="text"/>
ZONES:	9	10	11	12	13	14	16
1*20	<input type="text"/>	<input type="text"/>	<input type="text"/>	<input type="text"/>	<input type="text"/>	<input type="text"/>	<input type="text"/>
ZONES:	17	18	19	20	21	22	24
1*21	<input type="text"/>	<input type="text"/>	<input type="text"/>	<input type="text"/>	<input type="text"/>	<input type="text"/>	<input type="text"/>
ZONES:	25	26	27	28	29	30	32
1*22	<input type="text"/>	<input type="text"/>	<input type="text"/>	<input type="text"/>	<input type="text"/>	<input type="text"/>	<input type="text"/>
ZONES:	33	34	35	36	37	38	40
1*23	<input type="text"/>	<input type="text"/>	<input type="text"/>	<input type="text"/>	<input type="text"/>	<input type="text"/>	<input type="text"/>
ZONES:	41	42	43	44	45	46	48
1*24	<input type="text"/>	<input type="text"/>	<input type="text"/>	<input type="text"/>	<input type="text"/>	<input type="text"/>	<input type="text"/>
ZONES:	49	50	51	52	53	54	56
1*25	<input type="text"/>	<input type="text"/>	<input type="text"/>	<input type="text"/>	<input type="text"/>	<input type="text"/>	<input type="text"/>
ZONES:	57	58	59	60	61	62	63

- 1*26 FIRST RF RECEIVER SELECT 1=yes; [0=no]
- 1*27 SECOND RF RECEIVER SELECT 1=yes; [0=no]
- 1*28 RF TRANSMITTER LOW BATTERY ANNUN.
1=immediate; [0=when disarmed] Must be "1" for UL
- 1*29 RF TRANSMITTER LO BAT REPORT ENABLE
1=enable; [0=disable] Must be "1" for UL
- 1*30 RF RECEIVER SUPERVISION CHECK-IN INTERVAL
02-15 times 2 hours;
00 disables supervision [6] Max. "6" (12 hr) for UL
- 1*31 RF TRANSMITTER CHECK-IN INTERVAL
02-15 times 2 hours;
00 disables transmitter supervision [12] Max. "6" (12 hr) for UL

1*32 NOT USED

- 1*33 TOUCH-TONE W/ROTARY
BACKUP ENABLE 1=enable; [0=disable]
- 1*34 COMM. SPLIT REPORT SELECTION
[0=no]; 1=alarms primary, others secondary;
2=open/close, test secondary, others primary; See *51 for comments.

1*35-1*39 NOT USED

ARMED STAY DIALER REPORT

1*40 1*41
 First Digit Second Digit
 Armed Stay

This report will be sent for any Low Speed format. If Ademco High Speed is used, a normal closing report will be sent. If Contact ID is used, a new code, R441, will be sent. 685 Receivers that do not have revision 4.5 or higher will print an error message in place of the English text.

- 1*44 RF KEYPAD TAMPER DETECT 1=yes; [0=no]
- 1*45 ENABLE CONSOLE ANNUNCIATION.
DURING EXIT DELAY 1=enable; [0=disable]
- 1*46 AUXILIARY OUTPUT ENABLE
0=ground start; 1=open/close trigger (TERM 9); 2=Not used;
[3=Zone 1 EOLR]
- 1*47 ENABLE CHIME ANNUNCIATION ON
EXTERNAL ALARM SOUNDER 1=enable; [0=disable]

- 1*48 WIRELESS KEYPAD DISABLE
1=disable; [0=enable]
- 1*49 DISABLE TROUBLE SOUNDER FOR RF
SUPERVISION [1=disable]; 0=enable. Must be "0" for UL.
- 1*50 BABYSITTER CODE 1=enable; [0=disable]; (User 22)
- 1*51 4281 HOUSE ID Enter 01-31
- 1*52 CANCEL REPORT RESTRICTION
1=no restriction; [0=within Bell Timeout period only]
- 1*53 DOWNLOAD CALLBACK
1=callback not required; [0=callback required]; Must be "0" for UL.
- 1*54 HIGH SECURITY MODE
1=6-digit high security; [0=4-digit normal]

1*55-1*56 NOT USED

- 1*57 TRIGGER MODE 0, [1], 2, 3. See Table below

ADDRESS		Trigger Output 1	Trigger Output 2	Trigger Output 3
1*57 Trigger Mode	*15 Keyswitch			
0	0	FIRE LRR TRIGGER	PANIC LRR TRIGGER	BURG LRR TRIGGER
	1	KEYSWITCH ARMED LED	KEYSWITCH READY LED	
1	0	FIRE LRR TRIGGER	PANIC LRR TRIGGER	ZONE 6 GLASS BREAK RESET
	1	KEYSWITCH ARMED LED	KEYSWITCH READY LED	
2	0 1 not allowed	FIRE LRR TRIGGER	REMOTE SOUNDER	BURG LRR TRIGGER
3	0 1 not allowed	FIRE LRR TRIGGER	REMOTE SOUNDER	ZONE 6 GLASS BREAK RESET

NOTE: IF ADDRESS 1*57 IS SET FOR 2 OR 3, ADDRESS *15 MUST BE 0.

- 1*58 4219 FIRST ZONE NUMBER [00], 09-57
- Set to 00 if no 4219s used. If using a 4219, set to 1st zone # which will be assigned to zone A on 4219. Remaining 7 zones on 4219 will be the next 7 zone #s.

HEXADECIMAL TO NUMERIC ENTRY CONVERSION
0 = 10 (REPORT CODES)
0 = 00 (SUBS ID, PABX OR DOWNLOAD ID)
1 = 01, 2 = 02, 3 = 03, 4 = 04, 5 = 05, 6 = 06, 7 = 07, 8 = 08, 9 = 09,
B = 11, C = 12, D = 13, E = 14, F = 15,
A = 10 (DOWNLOAD ID ONLY)



A Division of Pittway Corporation
165 Eileen Way, Syosset, New York 11791
 Copyright © 1993 PITTWAY CORPORATION