

Dear Tech-Man Subscriber:

ADEMCO apologizes for any misunderstanding that has arisen due to our recent decision to have our technical information removed from the Tech-Man web site. You may appreciate that one of our key concerns is to provide installing security dealers with timely and accurate information on our products, and we were concerned about the data posted to the Tech-Man web site. For obvious reasons, we also do not wish unauthorized individuals to have access to information on installing and configuring ADEMCO systems. These concerns were what prompted us to ask Tech-Man to stop posting ADEMCO installation instructions and user manuals.

Several of you have written us to ask that we reconsider this decision. We have. We will not require Tech-Man to remove the ADEMCO data. ADEMCO, however, is not responsible for the operation and maintenance of this site - thus we cannot guarantee the timeliness or accuracy of the information posted on the Tech-Man web site.

The ADEMCO web site is located at www.ademco.com and contains accurate timely data about our products. You may request a PIN number for access to the ADEMCO Technical Support web site and FAXBACK system.

If you need assistance on troubleshooting, or if you have other technical questions about our products not addressed in the information posted at our web site, please contact ADEMCO Technical Support at 800-645-7492.

Thank you for understanding.

Sincerely,

Herb Lustig

INSTALLATION INSTRUCTIONS

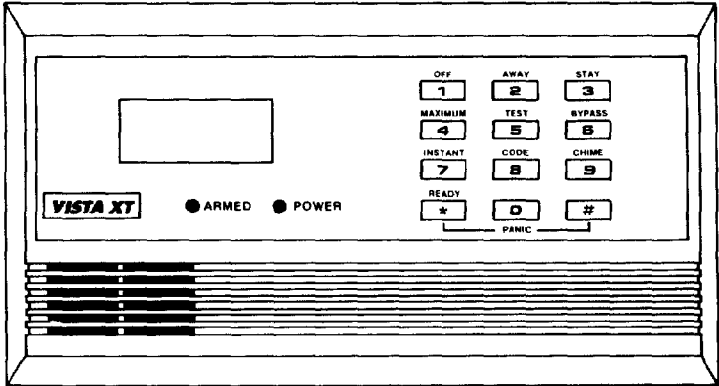

ADEMCO

VISTA
SECURITY SYSTEM
No. 4130XT

N3122-1 10/88

CONTENTS

General Information	4
Remote Programming and Control	5
Zone Types Available for Selection	7
Functional Description of Zone Types	8
Zone Expansion	12
4-Digit Security Codes	12
Wiring Connections	16
Remote Keyswitch Operation and Wiring	18
Optional Remote Keypad Connection (4131/4147)	18
Optional Remote Console Connection (4137/4157)	19
Installing the Digital Communication Interface Board	20
Installation of No. 4152LM and Wiring to No. 4208	21
Mounting the 4130XT Control	22
Surface Mounting	22
Flush Wall Mounting	24
Programming the Security Control	28
Factory Preset Values	29
Specific Address Programming Instructions	40
Testing the System	70
Turning the System Over to the User	71
To the Installer	71
Recalling Alarm and Trouble Messages	71
Replacing Fuses on 4130XT Circuit Board	72
Replacement Parts	73
Optional Accessories	73
FCC Statement	74
Specifications	75
4130XT Security Control	75
4171XT Digital Communication Interface Board	75

4137 Remote Console	75
4157 Remote Console	76
4131 / 4147 Remote Keypad	76
4152LM Loop Module	76
4208 8-Zone Expander	77
Appendix A. Cabinet Mounting	77
The Limitations of this Alarm System	80
Limited Warranty	82

Diagrams

Diagram 1. Summary of Connections	17
Diagram 2. 24-Pin Connector with Flying Leads (4130XT Field Wiring Interface)	18
Diagram 3. Keyswitch Wiring	19
Diagram 4. Installing the Digital Communication Interface Board	20
Diagram 5. 4152LM Installation and Wiring to 4208	21
Diagram 6. 4130XT Connector Interfacing and 4171XT Wiring Connections	23
Diagram 7. Inserting Nameplate	24
Diagram 8. Wall Preparation for Flush Mounting	26
Diagram 9. Flush Mounting the 4130XT/4137/4147	27
Diagram 10. Removing Main Circuit Board for Fuse Replacement	72

Template for Mounting the 4130XT/4137/4147 (provided on separate sheet)

GENERAL INFORMATION

The VISTA 4130XT is a microprocessor-based security control which provides up to 9 wired zones in the basic product, with expansion to an additional 8 wired zones when connected to a 2-wire zone expansion bus driven by the optional No. 4152LM Loop Module. The security control is housed in a wall-mounted plastic enclosure measuring only 8.4" (21.3 cm) wide x 4.75" (12 cm) high x 1.1" (2.8 cm) deep, and is equipped with a multifunction 12-key digital keypad, a multipurpose LCD English language display and a built-in 85 db piezoelectric sounder that meets UL requirements as an alarm sounder (an external sounder is therefore optional). Connections to the security control are made via a 24-pin plug-in connector equipped with flying leads which interface to the wired loops, plug-in DC Power Pack, back-up battery, optional external alarm sounder, etc.

The security control is programmable from its own keypad or from a 4137 or 4157 remote console (optional), and can also be programmed locally from the 699 Programmer (using a 695-30XT cartridge). Programmed options to establish specific alarm and reporting features are stored in electrically erasable, non-volatile EEPROM memory. This means that the unit can be reprogrammed many times (unlike units equipped with PROMS) and that information which has been programmed will not be lost in the event of a complete loss of power. For installer convenience, the control is factory-programmed to a set of values that is designed to meet the needs of many installations. However, these can be altered by the installer to suit the specific needs of a particular installation or installation company, following the instructions provided in the programming section of this manual (factory-programmed values are also shown in this section).

A plug-in Communication Interface board (4171XT) is required with this system and provides communication capability (central station reporting, etc.) over existing telephone lines as well as zone expansion connections.

An optional, economical, remote keypad (4131 or 4147) can be used for arming, disarming, etc., from a remote indoor location within the protected premises. This unit is a compact 12-button keypad with two system status indicators (LEDs) and a built-in piezoelectric sounder that provides warning and alarm sounds. Requires a 10-wire connection to the control.

An optional remote console (4157) will provide system status indications and will permit virtually all system control functions from its keypad. The console will also provide visible and audible indications of troubles and alarms by means of LEDs and numeric (zone number) display and built-in piezoelectric sounder. Requires only a 4-wire connection to the control.

An optional remote console (4137) is available which is identical to the 4130XT control in its appearance, system operation, LCD displays, and loud piezoelectric alarm sounder. Requires only a 4-wire connection to the main control.

A complete list of optional accessories will be found in a section toward the end of this manual under the heading "Optional Accessories" (see Index).

Zone Characteristics

- Zone 1:** Programmable Zone, may be used as EOLR supervised Fire Zone (supports 2-wire Smoke Detectors), or may be used as a non-fire zone with N.C. contacts only, 350-500 msec response.
- Zones 2-8:** Programmable Zones, EOLR supervised, 350-500 msec response.
- Zone 9:** Programmable Zone, N.C. contacts only, fast 10-15 msec response.

Back-up 12V DC Battery

Mounted externally. A special backbox (4132) is available for mounting the battery in the wall behind the Control. Rechargeable 12-volt, 1.2 AH Lead Acid.

DC Power Pack

Plug-in Power Pack (DC power converter). Plugs into unswitched 2-prong 110 volt AC outlet providing 24-hour service. Power Pack (1350) supplies unregulated 18V DC output (700 mA max) for powering the Control.

REMOTE PROGRAMMING AND CONTROL

The No. 4130XT allows the installer to call it using switched network phone lines so that the control/communicator can be remotely programmed and/or commanded from a No. 699MD Intelligent Programmer or an IBM compatible Personal Computer (PC). See Note 2 under **Remote Capabilities** in this section.

Accessing of the No. 4130XT from a remote location is protected against compromise by someone attempting to defeat the system, using 4 levels of security protection:

1. **Security Code Handshake:** An 8 digit Central Station ID code must be matched between the No. 4130XT and the Central Station.
2. **Hang-up and call back:** Calling the No. 4130XT does not directly allow programming, as a successful handshake merely results in the No. 4130XT breaking the phone line connection and then calling back the (internally stored) central station service phone number*.
3. **Data Encryption:** Data passed between the central station and the No. 4130XT is encrypted for security so that it is very difficult for a foreign device tapped into the phone line to take over communication and substitute system compromising information.

***NOTE:** In situations where a service person is on site and the system is installed inside a PABX, it is possible to initiate a download from the protected premises by keying [installer or master security code] + [#] + [1].

4. **Central Station Advisory Note:** Any condition that causes the system to initiate a call back to a telephone number from which it can be reprogrammed or commanded (in fact, even for a local reprogramming of the EEPROM) causes a unique report to be sent to the central station's alarm logging digital receiver.

Equipment Required

At the premises:

The No. 4130XT must be used with its No. 4171XT Communication Interface board if remote programming and/or control is desired.

At the central station (or the installer's office/home):

- A No. 699MD Intelligent Programmer that incorporates an internal modem and a No. 695-30XT Program Cartridge.
- OR**
- An IBM PC compatible computer, a Modem (check with Ademco Factory Technical Support for the specific brand and model to be used), No. 4130PC Downloading Software Diskette, and appropriate interconnecting cables.

Remote Capabilities (See Note 2)

Programming:

All programming functions accessible from the unit's keypad or via local No. 699 direct programming.

Commanding:

There are two types of commands that can be issued to the system:

1. Control Commands —

- To Arm the System in the Away Mode* (1)
- To Disarm the System* (1)
- To Bypass a Zone
- To Force the System to Accept a New Program Download
- To Shut Down Communication (dialer) Functions (non-payment of monitoring fees in an owner's system)
- To Shut Down all Security System Functions (non-payment for a leased system)
- To Inhibit Local Keypad Programming (prevents takeover of your accounts)

2. Status Commands —

- To Cause the System to Upload a Copy of its Resident Program to the central station
- To Read System Status:
 - Arming Status
 - Ready Status and Current Faults
 - Presence of Alarms (past or present)
 - Presence of Troubles (past or present)
 - AC Power Status
 - Bypass Status and Current Bypasses

***NOTES:** 1. If the system is programmed for open/close reporting by user, User #7 will be reported.

2. After the 4130XT and the 699 or PC have established valid communication, each 4157 console displays an 'OC' signifying that it is busy (occupied). Also, the 4130XT is not responding to faults in its zones. The 4130XT will resume the normal security functions (including responding to faults that took place during the downloading) after it is com-

manded to hang up. See the 4130PC or 695-30XT instructions for details.

The detailed operation of the functions described below is covered in the Installation Instructions for the No. 695-30XT Program Cartridge and for the 4130PC Download Software Diskette.

- To Read List of Faulted Sensors
- To Read List of Bypassed Sensors
- To Read 10 Day Alarm History Log
- To Read 10 Day Trouble History Log
- To Read List of Sensors Currently in Alarm
- To Read List of Sensors Currently in Trouble

Remote Communication Specifications:

- Program Download Time — 1 minute for a complete program
- Typical Total Time Including Call Up/Call-Back — 3-4 minutes.

Remote Command/Programming Advisory Notes:

- Alarm and Trouble Reporting are disabled during the time that the system and the central station are linked to each other for the described functions, following a valid exchange of codes.
- Keypad entries are ignored during the same time interval cited above.
- Should an alarm transpire during the remote program/control interval, the system would not respond to the alarm condition until the remote mode was ended. The local zones and the Nos. 4190WH, 4192, 4194WH, 4196, and 4208 all store their fault conditions until they are read by the Control. As such, alarm conditions from the local and expansion zones would not be missed, only delayed.
- A copy of the program downloaded may be produced from either the No. 699 Intelligent Programmer or the IBM PC compatible computer, using those products' internal report generators, when an optional printer is connected.

ZONE TYPES AVAILABLE FOR SELECTION

For each zone used, one of the following zone types must be selected:

1. **Entry/Exit Burglary (Delay #1).** Assigned to sensors on doors through which entry and exit will normally take place when the system is armed.
2. **Entry/Exit Burglary (Delay #2).** May be set for different delay than above. For use with sensors on overhead garage doors, etc., where longer delay is needed to reach the keypad in the main portion of the house or building, and more delay is needed to exit the premises.
3. **Perimeter Burglary.** Normally assigned to all sensors on exterior doors and windows requiring instant alarm.
4. **Interior, Follower.** Delayed alarm only if the Entry/Exit zone is faulted first; otherwise, produces an instant alarm. Assigned to zone covering an area such as a foyer or lobby through which one must pass upon entry to reach the keypad to disarm the system. Designed to provide instant intrusion alarm in the event an intruder hides on the premises prior to the system being armed or gains access to the premises through an unprotected area.
5. **Trouble by Day/Alarm by night.** Can be assigned to a zone which contains a foil-protected door or window (such as in a store), or to a zone covering a "sensitive" area such as a stock room, drug supply room, etc., or other controlled access area where immediate notification of an entry is desired. During the disarmed state (day), the system will provide latched Control/Console annunciation (and central station report, if desired) of openings or troubles (such as sensor malfunctions or foil breaks). During the armed state (night), violations will initiate an alarm.
6. **24-hour Silent Alarm.** This type generally assigned to a zone containing an Emergency button that is designed to initiate an alarm report to the Central Station, but which produces no local displays or alarm sounds.
7. **24-hour Audible Alarm.** This type also assigned to a zone containing an Emergency button, but which will initiate an audible alarm in addition to an alarm report to the Central Station.
8. **24-hour Auxiliary Alarm** (Control internal sounder only). This type assigned to a zone containing a button for use in personal emergencies, or to a zone containing monitoring devices such as water sensors, temperature sensors, etc. Designed to initiate an alarm report to the Central Station and also provide Control/Console alarm sounds and alarm displays.
9. **Supervised Fire** (alarm on short/trouble on open).
10. **Interior that always has Entry/Exit Delay #1** (except that Entry delay is suppressed in the INSTANT mode). This type typically assigned to an interior zone containing a PIR that covers an area through which the user must pass to reach the Control for disarming purposes (whether inside or first entering). Ideal for an area such as an apartment entrance foyer in which a keypad is located.

FUNCTIONAL DESCRIPTION OF ZONE TYPES

The following is a description of the various zone types available which must be selected for each physical zone. You may wish to use Table A at the end of this description to record your selections.

Type 1. BURGLARY ENTRY/EXIT (DELAY #1): This zone type is not enabled after arming until termination of the (EEPROM defined) Exit delay #1. Upon entry, the Control will simply emit three short beeps as a warning that the system must be disarmed (for added security, this system does not emit warning signals throughout the Entry delay period). If Code + OFF is not entered before termination of the (EEPROM defined) Entry delay #1, an alarm will be initiated at the built-in sounder, if program enabled, and an external alarm and latched LCD display. If a Communication board is used, a system-wide EEPROM defined number of alarm reports for this zone will be allowed to be transmitted (swinger suppression) in one armed period. Restorals will be sent when the zone is restored for a time greater than its physical response time (less than 1 second).

During the disarmed state, a faulted zone will result in a NOT READY display. Subsequent depression of the READY key will cause all the faulted zones to be sequentially displayed. No communicator reports will be initiated.

Type 2. BURGLARY ENTRY/EXIT (DELAY #2): This zone type is not enabled after arming until termination of the (EEPROM defined) Exit delay #2. Upon entry, the Control will simply emit three short beeps as a warning that the system must be disarmed (for added security, this system does not emit warning signals throughout the Entry delay period). If Code + OFF is not entered before termination of the (EEPROM defined) Entry delay #2, an alarm will be initiated at the built-in sounder, if program enabled, and an external alarm and latched LCD display. If a

Communication board is used, a system-wide EEPROM defined number of alarm reports for this zone will be allowed to be transmitted (swinger suppression) in one armed interval. Restorals will be sent when the zone is restored for a time greater than its physical response time (less than 1 second).

During the disarmed state, a faulted zone will result in a NOT READY display. Subsequent depression of the READY key will cause all the faulted zones to be sequentially displayed. No communicator reports will be initiated.

Type 3. BURGLARY PERIMETER: While the System is armed, a faulted zone will initiate an alarm at the built-in sounder, if program enabled, and an external alarm, a latched LCD display, and a (EEPROM selected) communicator report. Depression of any key will silence the Control's local alarm sounder for 10 seconds. A system-wide EEPROM defined number of alarm reports for this zone will be allowed to be transmitted (swinger suppression) by the communicator in one armed period. The communicator will transmit a restoral message when the zone is restored for a time greater than its physical response time (less than 1 second).

During the disarmed state, a faulted zone will result in a NOT READY display. Subsequent depression of the READY key will cause all the faulted zones to be sequentially displayed. No communicator reports will be initiated.

Type 4. BURGLARY INTERIOR, FOLLOWER: This zone will always have Exit Delay #1. The zone has an Entry Delay if preceded by a fault in an Entry/Exit zone (type #1 or #2). If not preceded by an Entry/Exit zone fault, an immediate audible local (Control) and external alarm, latched display, and a (EEPROM selected) communicator report are initiated. Depressing any key at the Control will silence the Control sounder for 10

seconds. A system-wide EEPROM defined number of alarm reports for this zone will be allowed to be transmitted (swinger suppression) by the communicator in one armed period. The communicator will transmit a restoral message when the zone is restored for a time greater than its physical response time (less than 1 second).

During the disarmed state, a faulted zone will result in a NOT READY display. Subsequent depression of the READY key will cause all the faulted zones to be sequentially displayed. No communicator reports will be initiated.

Type 5. BURGLARY PERIMETER, TROUBLE BY DAY/ALARM BY NIGHT:

During the disarmed state (day), faulting the zone will initiate a "trouble" display and a latched sounder (beeping). The Control will beep rapidly along with a latched display of the faulted zone and the word CHECK. Pressing any key will silence the beeping for 10 seconds. Code + OFF will silence the beeping but will only clear the display of a zone that had the fault condition removed.

If a Communication board is used, each trouble will result in a "trouble" report (if programmed). A trouble restoral message will be sent as each zone is restored to normal condition. The maximum number of trouble reports per armed period will be limited by the system-wide EEPROM number of alarm reports option (swinger suppression).

During the armed state (night), the local (Control) and external (if used) alarm sounder will activate and the communicator will report alarms. A system-wide EEPROM defined number of alarm reports for this zone will be allowed to be transmitted in one armed period. Restorals will be sent when the zone is restored for a time greater than its physical response time (less than 1 second).

Type 6. 24-HOUR SILENT ZONE: Sensors assigned to this zone, when faulted, will initiate a communicator report. There will be no local displays or alarm sounds. Upon keying Code plus OFF, there will be a memory indication of the faulted zone.

A system-wide EEPROM defined number of alarm reports for this zone will be allowed to be transmitted (swinger suppression) by the communicator until an OFF sequence is performed. The communicator will transmit a restoral message when the zone is restored for a time greater than its physical response time (less than 1 second).

During the disarmed state, NOT READY will be displayed if a sensor is faulted. The burglary portion of the system cannot be armed if this zone is faulted. An OFF sequence (code plus OFF) should be performed prior to arming the system or viewing the faulted zones via the *key.

Type 7. 24-HOUR AUDIBLE ZONE: Faulting a zone of this type will initiate a loud audible alarm externally and at the Control, an LCD display, and a (EEPROM selected) communicator report. Pressing any key will silence the Control sounder for 10 seconds. Keying Code plus OFF will permanently silence the alarm. A system-wide EEPROM defined number of alarm reports for this zone will be allowed to be transmitted (swinger suppression) by the communicator until an OFF sequence is performed. The communicator will transmit a restoral message when the zone is restored for a time greater than its physical response time (less than 1 second).

Type 8. 24-HOUR AUXILIARY ZONE: Faulting a zone of this type will initiate a steady alarm sound at the Control, an ALARM display, and a (EEPROM selected) communicator report. Pressing any key will silence the Control sounder for 10 seconds. Keying Code plus OFF will permanently silence the

alarm. A system-wide EEPROM defined number of alarm reports for this zone will be allowed to be transmitted (swinger suppression) by the communicator until an OFF sequence is performed. The communicator will transmit a restoral message when the zone is restored for a time greater than its physical response time (less than 1 second).

Type 9. FIRE ZONE: Opens in this zone will result in "troubles". Shorts will result in alarms. **Note:** Zone 1 will support 2-wire Smoke Detectors (using the EOL resistor configuration); Zones 2 through 8 can be used for heat detectors and pull stations and for 4-wire Smoke Detectors with external (manual) power interrupt; Zone 9 cannot be used for Fire.

Fire zones may not be bypassed. A fire zone in trouble will not prevent the burglary system from being armed in any mode.

A system-wide EEPROM defined number of alarm reports for this zone will be allowed to be transmitted (swinger suppression) by the communicator in one armed period. The communicator will transmit a restoral message when the zone is restored (less than 1 second).

Type 10. INTERIOR DELAY ZONE: This type of zone will always have an Entry delay #1 and Exit delay #1. This zone is not enabled after arming until termination of the (EEPROM defined) Exit delay #1. If this zone is faulted, three beeps will be emitted by the Control. If Code + OFF is not entered before termination of the (EEPROM defined) Entry delay #1, an alarm will be initiated. A system-wide EEPROM defined number of alarm reports for this zone will be allowed to be transmitted (swinger suppression) by the communicator in one armed period. The communicator will transmit a restoral message when the zone is restored for a time greater than its physical response time (less than 1 second).

During the disarmed state, a faulted contact will result in NOT READY being displayed. Subsequent depression of the READY key will cause all the faulted zones to be sequentially displayed, but no communicator reports will be initiated.

TABLE A. ZONE ASSIGNMENTS

A zone type must be assigned to each physical zone in use. For convenience, the following chart has been provided for checking off selections made.

ZONE TYPE	PHYSICAL ZONES																	
	1	2	3	4	5	6	7	8	9	10	11	12	13	14	15	16	17	
1. ENTRY/EXIT, Delay #1 (Burglary)																		
2. ENTRY/EXIT, Delay #2 (Burglary)																		
3. PERIMETER (Burglary)																		
4. INTERIOR, FOLLOWER (Burglary)																		
5. TROUBLE BY DAY / ALARM BY NIGHT (Burglary)																		
6. 24-HOUR SILENT																		
7. 24-HOUR AUDIBLE																		
8. 24-HOUR AUXILIARY																		
9. FIRE ZONE*																		
10. INTERIOR, DELAY (Burglary)																		

*Physical Zone 9 cannot be used for Fire.

ZONE EXPANSION

Zone expansion to an additional 8 zones is achieved by first installing the optional No. 4152LM Loop Module onto the No. 4171XT (after it has been installed). The No. 4152LM can then be connected to a No. 4208 Eight Zone Expander by a single pair of wires providing both power and signaling. Each of the 8 zones on the No. 4208 can be programmed from the various types described in this manual that are available for use on the basic 9 zones, with one exception. There is no ability to support 2 wire smoke detectors on any of the zones available in the No. 4208 Zone Expander. The No. 4208 Zone Expander may be located near the No. 4130XT or remotely from it. The two wire run to it should utilize twisted pair wiring and should **not** be run in close proximity to protected premises intercom wiring [at least a 3-inch (8 cm) separation]. For the maximum wiring run permissible to the zone expander for various wiring gauges, see the Specifications Section relative to the No. 4208 Zone Expander later in this manual.

IMPORTANT: In order to utilize the No. 4208 to obtain zones 10-17, that product's DIP switches must be set as follows:

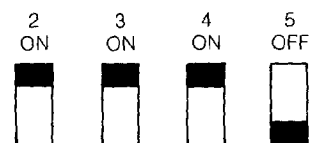

(as if set for sensor numbers 113-120, as cited in the instructions for the No. 4208)

Installation instructions for the No. 4152LM and wiring connections to the No. 4208 are provided in a subsequent section entitled "INSTALLATION OF No. 4152LM AND WIRING TO No. 4208".

4-DIGIT SECURITY CODES

Installer Code:

The installer programs the Installer Code initially as part of the programming procedure (see "Programming the Security Control"). In this system, the installer is considered to be user #1. The installer code permits re-entry into the programming mode (unless *98 has been previously used to exit the programming mode or if user #1 was not enabled in Address *52) and also allows access to the normal functions of the system. During initial programming, the installer also programs the Master security code into the system.

- Installer Code (User #1), assigned during programming.

Installer exits programming mode with:

- *99 (allows re-entry into programming mode with installer code).
- or
- *98 (does not allow re-entry to programming mode unless system is first powered down and then repowered). Installer code is disabled when this exit is used.

Master Security Code:

The Master security code can be used to assign up to thirteen secondary codes (to users #3-#15); it can also be used to remove all secondary codes from the system (individually). The person to whom the Master

code is assigned is considered to be user #2. In some applications (commercial installations, for example), user #2 (with Master code) will be the main user of the system (see Application 1 on a following page). In other applications (such as in an apartment complex, for example), user #2 (with Master code) may not be the actual end user of the system (see Application 2 on a following page).

Secondary security codes are assigned by user #2 (with Master Code) as follows:

Master Code + CODE key + User # (03-15) + Secondary Code

The system will emit a single beep when each secondary code has been successfully entered.

Note: When a secondary code is inadvertently repeated for different users, or one user's code is another's duress code, the lower user will take priority.

Individual secondary security codes can be deleted by user #2 (with Master Code) as follows:

Master Code + CODE key + User # (03-15) + Master Code

Note: All security codes, Master and secondary, permit access to the system for arming, disarming, etc.

Secondary (Temporary) Security Codes:

As stated previously, up to thirteen secondary codes can be assigned — to users 3 through 15. The configuration in Application 1 shows that secondary (or temporary) codes may be assigned by the primary user (user #2) to as many as thirteen employees, each with a unique code. Note that user #3 can also assign secondary codes to users 4-14 if required, but in the typical arrangement shown in Application 1, there may never be a practical need for this. If so, the primary user (#2) can elect to omit user #3 when assigning secondary codes.

In the configuration shown in Application 2, user #3, who is the primary

user, may need to assign secondary (temporary) codes to maids, cleaning persons, etc. Since the system allows user #3 to assign secondary or temporary codes to as many as eleven users (4-14), this need can be met. User #3 cannot assign (or delete) user #15's code, which is strictly under the control of user #2, who may be the building manager or owner in the configuration shown in Application 2. See Table B, which illustrates the various levels of authority that exist for security codes.

User #3 can assign secondary (temporary) codes for users, 4-14 as follows:

User #3 Code + CODE key + User # (04-14) + Secondary Code

User #3 can delete secondary codes assigned to users 4-14 as follows:

User #3 code + CODE key + User # (04-14) + User #3 Code

TABLE B. LEVELS OF AUTHORITY FOR SECURITY CODES

User No.	Can assign or delete Secondary Code of User:
#1 (Installer)	NONE
#2	#3 through #15
#3	#4 through #14
#4 - #15	NONE

APPLICATION 1

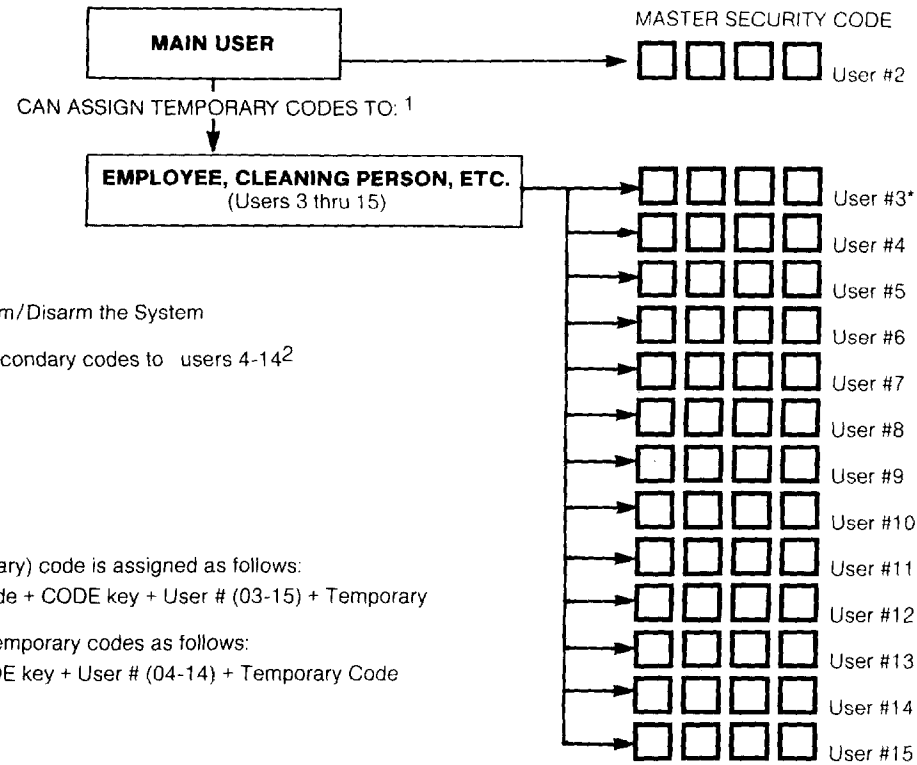

Note: All codes can Arm/Disarm the System

*User #3 can assign secondary codes to users 4-14²

¹ A secondary (temporary) code is assigned as follows:
User #2 (Master) Code + CODE key + User # (03-15) + Temporary Code

² User #3 can assign temporary codes as follows:
User #3 Code + CODE key + User # (04-14) + Temporary Code

APPLICATION 2

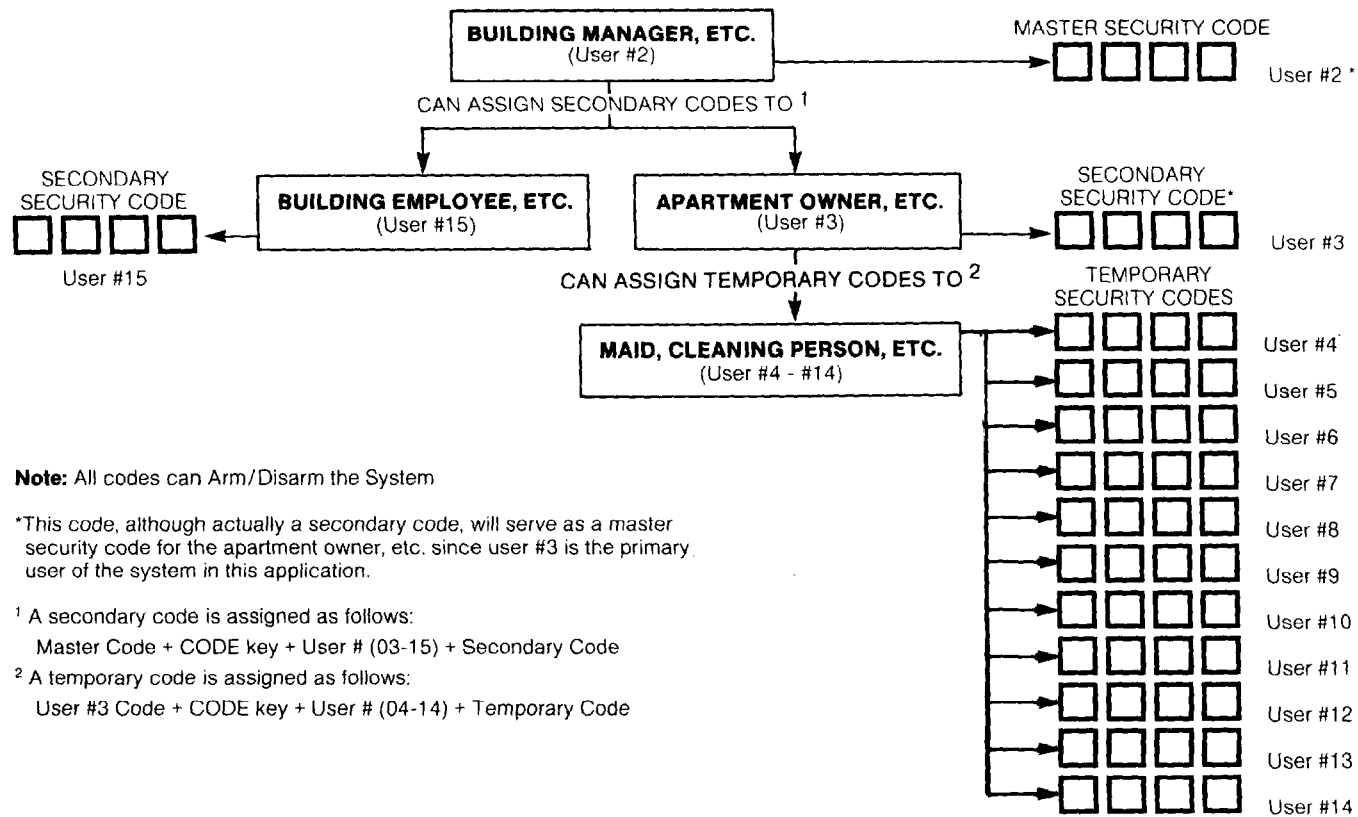

Note: All codes can Arm/Disarm the System

*This code, although actually a secondary code, will serve as a master security code for the apartment owner, etc. since user #3 is the primary user of the system in this application.

¹ A secondary code is assigned as follows:

Master Code + CODE key + User # (03-15) + Secondary Code

² A temporary code is assigned as follows:

User #3 Code + CODE key + User # (04-14) + Temporary Code

WIRING CONNECTIONS

(See Diagram 1, Summary of Connections)

A 24-pin plug-in connector with flying leads is provided to interface the 4130XT to the wired loops, the external alarm sounder, the back-up battery, to externally powered devices (auxiliary current), and to the plug-in DC Power Pack.

The 24 flying leads, each 18 inches (46 cm) in length, are uniquely color coded, as shown in Diagram 1 and also in Table C which indicates the color, usage and pin connection for each lead.

Note: Optional 30-ft (9 m) and 15-ft (4.6 m) wiring harnesses with a 24-pin connector at one end are available for interface wiring. Color coding

of wires used in these harnesses is identical to that used in the 24-pin connector with 18-inch leads. Refer to "Optional Accessories" for part numbers of available wiring harnesses.

Grounding the System

A proper earth ground **must** be provided for the system. The White lead (pin 11) on the 24-pin connector is the earth ground lead (see Table C). Connect this lead to a suitable earth ground (a metallic cold water pipe or electrical box may be used in some locations).

TABLE C. WIRE ASSIGNMENTS

Wire Color	Usage	Connector Pins	Usage	Wire Color
Blue	DC (-) INPUT (from plug-in DC Power Pack)	(12) (24)	DC(+) INPUT (from plug-in DC Power Pack)	Red/Green
White	EARTH GND	(11) (23)	BATTERY(+)	Red
Black	BATTERY (-) and REMOTE CONSOLE GROUND	(10) (22)	AUX/REMOTE CONSOLE/EXT ALARM SOUNDER PWR (+)	Red/Black
Violet	AUX PWR (-)	(9) (21)	EXT. ALARM SOUNDER(-)	Brown
Gray	ZONE RETURN	(8) (20)	ZONE 4(+)	White/Yellow
Tan	ZONE RETURN	(7) (19)	ZONE 5(+)	White/Green
White/Red	ZONE 2(+)	(6) (18)	ZONE 6(+)	White/Blue
White/Orange	ZONE 3(+)	(5) (17)	ZONE 9(+)	White/Black
White/Brown	ZONE 1 RETURN	(4) (16)	ZONE 7(+)	White/Violet
Orange	ZONE 1(+)-N.C Loop	(3) (15)	ZONE 8(+)	White/Gray
Pink	ZONE RETURN	(2) (14)	ZONE 1(+) EOLR Loop	Red/Yellow
Green	DATA IN (Remote Console)	(1) (13)	DATA OUT (Remote Console)	Yellow

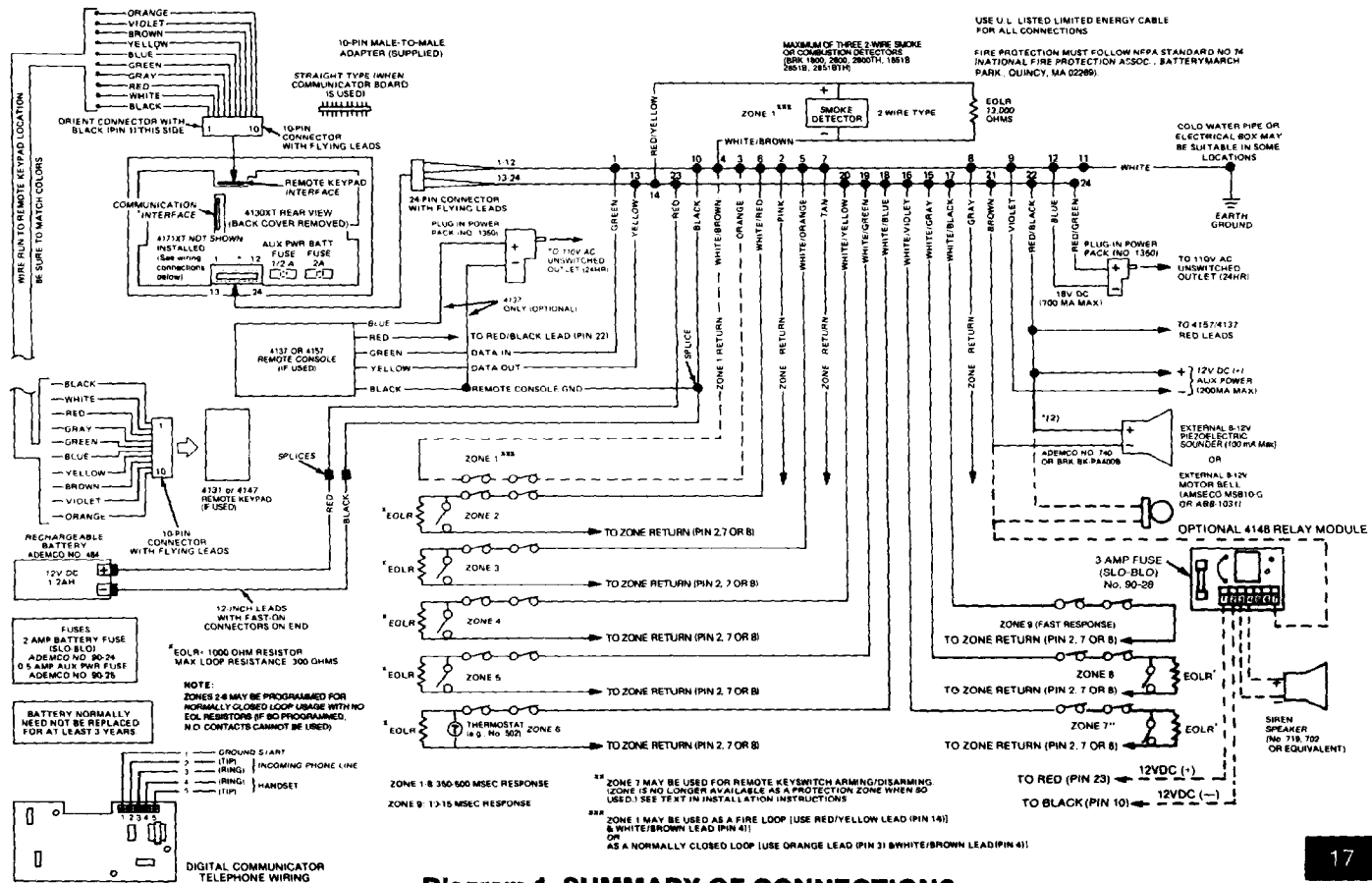

Diagram 1. SUMMARY OF CONNECTIONS

Remote Keyswitch Operation & Wiring

An optional Remote Keyswitch may be used for remote arming and disarming (this is an installer-programmed option). A normally-open momentary switch is connected across Zone 7 (which must be given up as a protection zone). A momentary short of the zone will arm the System in the AWAY mode; if the key is held (short maintained) for over 3 seconds, the System will arm in the STAY mode. When a momentary short is applied subsequently, the System will disarm. A keyswitch tamper (normally-closed) switch wired in series with zone 7 will disable keyswitch operation until the system is next disarmed via a keypad, if activated. Refer to Diagram 3 for Keyswitch wiring details.

NOTE: Regardless whether End-of-Line supervision is selected or not (in Address *41), an end-of-line resistor must still be used for proper functioning of the keyswitch.

Optional Remote Keypad Connection (4131/4147)

An optional remote keypad (4131/4147) may be used with the System. Two 10-pin female connectors have been supplied for keypad interfacing to the 4130XT Control (see Diagram 1, Summary of Connections). The two connectors, which are identical, are equipped with color-coded flying leads that are 12 inches (30 cm) in length.

One of these connectors is attached directly to the mating 10-pin male connector on the 4131/4147 remote keypad (the connector can only be inserted one way, and will lock in place).

The other connector is connected to the 4130XT Control via a "straight" male-to-male 10-pin adapter (supplied).

Specific information regarding the use of the adapter and connection to the 4130XT Control is provided in the section entitled MOUNTING THE 4130XT.

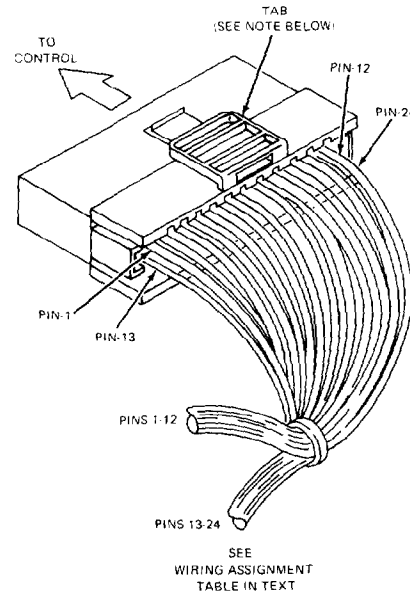

NOTE:
TO REMOVE CONNECTOR FROM CONTROL BOARD
AFTER INSERTION, SQUEEZE TAB AND PULL
OUTWARD WITH A SIDE-TO-SIDE ROCKING MOTION.

Diagram 2.
24-PIN CONNECTOR WITH FLYING LEADS
(4130XT WIRING INTERFACE)

RECORDING INSTALLATION DATA

When all interface wiring is completed, record wiring usage in the spaces provided on the Wire Assignment tag attached to the wires on the 24-pin connector. This will provide a permanent record of the interface wiring connections for future servicing.

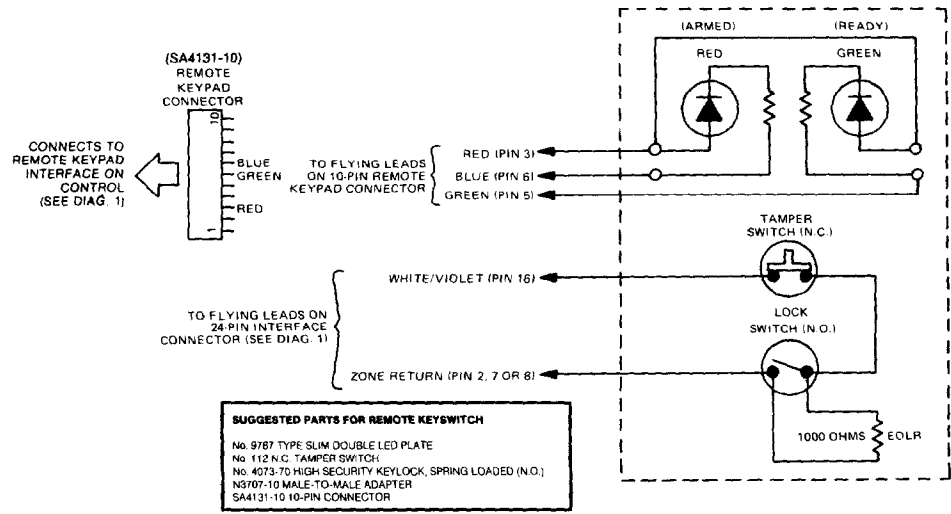

Diagram 3. KEYSWITCH WIRING

Optional Remote Console Connection (4137 or 4157)

An optional Remote Console (4137 or 4157) can be used with the System. Connections are as follows:

4137/4157 Leads	24-pin Connector Flying Leads
RED	to RED/BLACK (Pin 22)
GREEN	to GREEN (Pin 1)
YELLOW	to YELLOW (Pin 13)

BLACK to BLACK (Pin 10) For 4137, connect also to (-) output of separate No. 1350 Power Pack.
 BLUE (4137 only) to (+) output of separate No. 1350 Power Pack.
 Refer also to Diagram 1, Summary of Connections.

INSTALLING THE DIGITAL COMMUNICATION INTERFACE BOARD (4171XT)

The optional Digital Communication Interface Board is attached to the rear of the Control as follows (refer also to Diagram 4).

1. Remove the back cover on the Control. The securing screw at the left front of the Control must be removed to release the back cover (see Diagram 6 for screw location). Discard the back cover, but retain the screw for use later.
2. Insert three small plastic standoffs (supplied) into the three holes on the Control board identified as "A", "B" and "C" in Diagram 4. Press them in firmly until they "snap" into place.
3. Insert the 13-pin male-to-male adapter (supplied) into the interface socket pin holes on the underside of the Communication Interface board, as shown.
4. Attach the Communication Interface Board to the Control board as follows. Guide the adapter pins (on the Communication board) into the interface pin holes on the Control board, simultaneously allowing the pointed ends of the standoffs to partially enter the holes in the Communication board (shown as "A", "B" and "C" in the Diagram). Before proceeding, make sure the adapter pins are properly entering the pin holes on the Control board. Then press the Communication board down until the connector pins are fully seated and the standoffs "snap" into place in the Communication board, thus holding the board securely to the Control.

This completes the installation of the Communication Interface board. Wiring connections are not made at this time.

**DO NOT CONNECT THE OUTPUT OF THE 4171XT
TO A FIRE OR POLICE HEADQUARTERS**

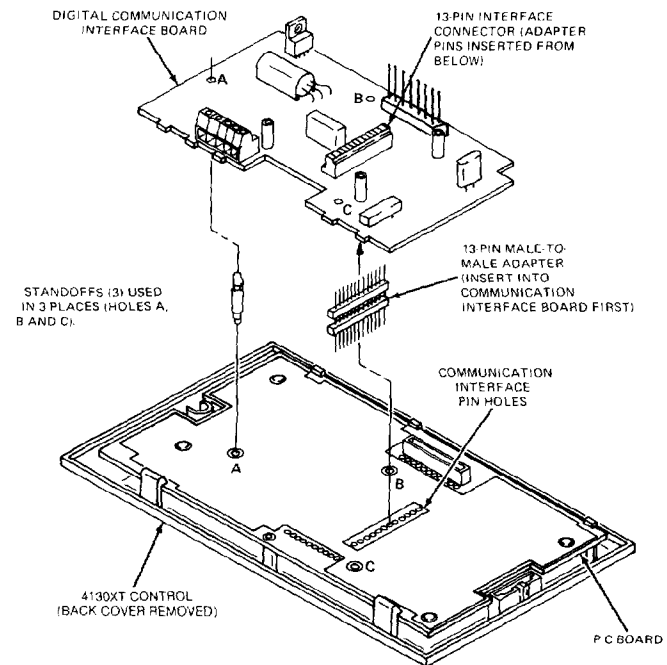

**Diagram 4. INSTALLING THE DIGITAL
COMMUNICATION INTERFACE BOARD**

INSTALLATION OF No. 4152LM AND WIRING TO No. 4208

The optional No. 4152LM Loop Module is installed onto the No 4171XT Digital Communications Interface board as follows, referring to Diagram 5.

a. Note the 8 square-shaped connector pins on the 4171XT board. Position the 4152LM board over the 4171XT board so that these pins engage the mating sockets (header) on the underside of the 4152LM. Press the 4152LM down until the pins are fully seated.

b. Secure the No. 4152LM by means of 3 screws (supplied).

Connect two wires from the loop terminals (1 and 2) on the 4152LM to terminals 11 and 12 (respectively) on the 4208 Zone Expander. For information on wire usage, etc., refer to a previous section entitled "ZONE EXPANSION".

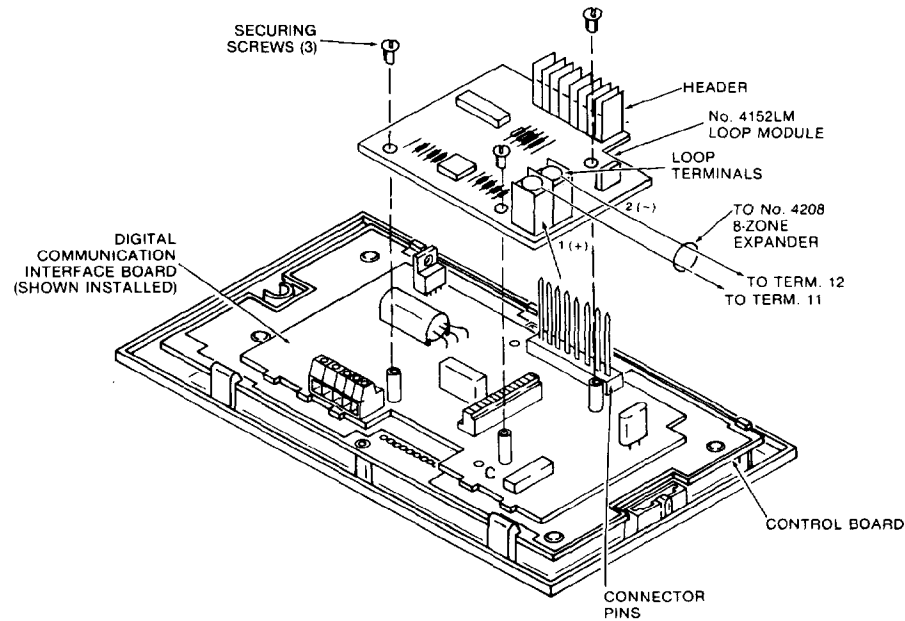

Diagram 5. No. 4152LM INSTALLATION AND WIRING TO No. 4208

MOUNTING THE 4130XT CONTROL

There are three methods that may be used for mounting the 4130XT Control, as follows:

1. **Surface Mounting:** This type of mounting is possible only when a battery backbox is not required (battery back-up power will be supplied from a remote location) and when the digital communication interface board is mounted to the unit using the No. 4143 Extender Ring to increase the depth of the unit.
2. **Flush Mounting:** This type of mounting is used when the battery backbox is required for support of the back-up battery in the wall behind the 4130XT, or when the No. 4143 Extender is not attached to the rear of the 4130XT Control. This mounting method is also applicable if a "rough-in" ring (4133) has been installed in the wall in a new construction application.
3. **Cabinet Mounting:** In buildings using concrete, cinder block or brick wall constructions, the surface or flush mounting method above may not be practical, and a third method using a wall-mounting metal cabinet can be used (see "Optional Accessories"). The 4130XT Control is mounted in a cut-out specially provided for this purpose in the door of the cabinet, and the back-up battery (if used) is installed within the cabinet. Also available for use within the cabinet are connector blocks which can be used to connect the 4130XT flying leads to the field wiring. Instructions for this type of mounting are provided in Appendix A toward the end of this manual.

Proper selection of mounting location and height is important for optimum viewability of the LCD display on the control (or remote console). A location in which lighting is directly above the control should be avoided, since this can shadow the display. For optimum viewing, the control should also be mounted so that the display is below eye level to ensure that the system's user will look down at the display.

Surface Mounting:

- Notes:**
1. This method of mounting is not applicable for UL installations.
 2. This method of mounting cannot be used if a 4152LM Loop Module is used.

Use the template provided (on a separate sheet) to mark the positions on the wall for the screw mounting holes and the cut-out for the interface wiring. Use wall anchors for the screws and make the cut-out in the wall no larger than indicated.

Pull the interface wiring in the wall through the cut-out. Splice these wires to the 24-pin interface connector wires as indicated in Diagram 1 and in Table C previously. Insulated solderless wire splices (such as Ademco No. 311) may be used for splicing. **Check wire connections carefully before splicing.**

Note: If the optional 15-ft (4.6 m) or 30-ft (9 m) wiring harness has been used for interface wiring, splices will not be necessary behind the control since these harnesses are terminated with a 24-pin connector which can be connected directly to the 4130XT.

If the 4131/4147 Remote Keypad is being used, splice those wires to the wires on the 10-pin connector supplied for this purpose, **being sure to match wire colors.** Be sure to insulate all splices.

Remove the Control's back cover. The securing screw at the front of the Control must be removed to release the back cover (see Diagram 7 for screw location). Pass the interface connector(s) through the opening in the back cover and then mount the back cover to the wall surface with screws.

Install the No. 4143 Extender Ring onto the back cover (see the instructions accompanying the No. 4143).

Attach the interface connector(s) to the board at the rear of the Control as follows, referring to Diagram 6:

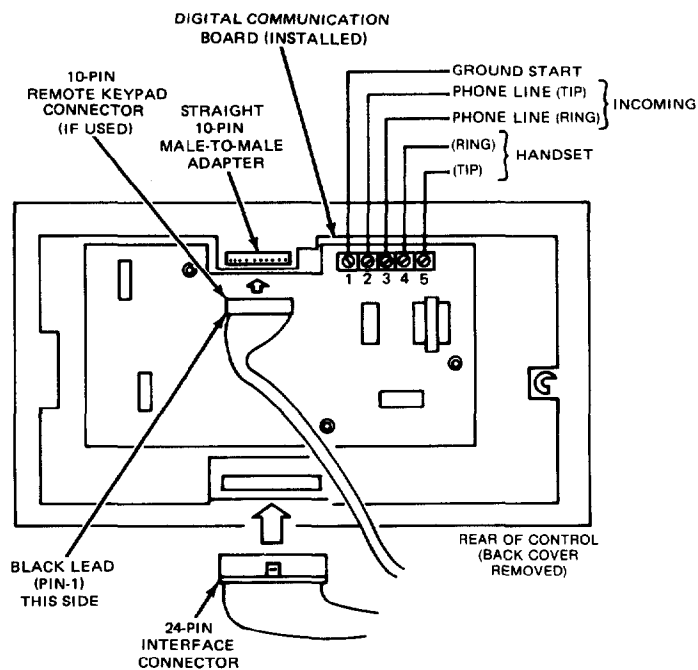

Diagram 6. 4130XT CONNECTOR INTERFACING AND 4171XT WIRING CONNECTIONS

- a. Attach the 24-pin connector to the mating interfacing pins located at the bottom of the board.
- b. Attach the 10-pin connector (if used) to the Remote Keypad connector (10-pin socket) at the top of the board via the "Straight" male-to-male adapter supplied. **Important:** Be sure to orient the connector with BLACK lead (pin 1) to the left (when viewing the 4130XT from the rear).
- c. On the Digital Communication interface board, attach the interconnecting wires to the terminal block as follows, referring also to Diagram 6:

Communication Interface Board Terminal	Wire Assignment
1	Ground Start *
2	Incoming Phone Line (Tip)
3	Incoming Phone Line (Ring)
4	Handset (Ring)
5	Handset (Tip)

*Connect to BLUE lead on 675 Ground Start Module.

- d. With a pair of wire-cutting pliers, snip off the 8 square-shaped connector pins that normally interface to the 4152LM and then install the 4171XT Digital Communication Interface board. **Note:** On later production units, this procedure will not be necessary. Those units will be accompanied by a note to that effect.

Attach the main body of the Control to the Extender Ring, which is attached to the wall-mounted back cover. The Control is properly attached when it "snaps" into place.

Use the securing screw (supplied with the No. 4143 Extender Ring) to secure the Control to the back cover (see Diagram 7 for location of screw hole), then insert the small VISTA XT nameplate supplied into the recessed opening to cover the screw head, as shown in Diagram 7.

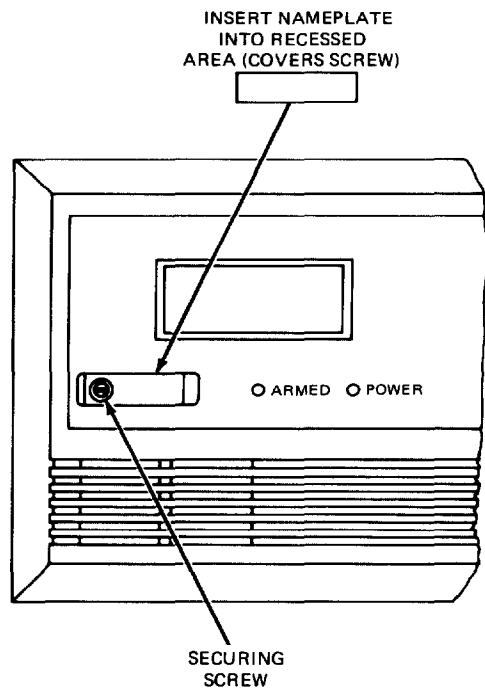

Diagram 7. INSERTING NAMEPLATE

Flush Wall Mounting:

If a "rough-in" ring (4133) has been previously installed in the wall (during new construction), disregard step 1 and proceed to step 2 since the required opening for the Control is already present. If a wall plate (4136) is installed over the rough-in ring, remove the plate to expose the opening.

1. Cut an opening measuring 4-5/16" (11 cm) high by 7-3/4" (20 cm) wide between studs in the wall. The opening must be no less than 1-1/2" (4 cm) from either stud. Avoid cutting the opening any larger than that specified. See Diagram 8.

Note: A special "trim ring" has been supplied for installation between the wall and the Control for those cases where the opening has inadvertently been made too large (over-cutting). The Control fits into the recess in the trim ring which will extend 1/2" (1.3 cm) beyond the Control front panel, and thus cover any opening that might otherwise be visible as a result of over-cutting.

2. Remove the back cover on the Control. The securing screw at the front of the Control must be removed to release the back cover (see Diagram 7 for screw location). Discard the back cover, but retain the screw.

Note: Make sure that the digital communication interface board is mounted to the 4130XT (and the No. 4152LM Loop Module, if applicable), as indicated previously.

3. Install the Battery Backbox (4132). (Disregard this step if battery back-up power is supplied from a remote location.) If battery back-up power is not supplied from a remote location, the backbox supplied must be installed behind the wall opening to support the back-up battery that must be used. Install as shown in Diagram 8, with "lip" of the backbox hooked over the bottom edge of the wall opening.

Insert the battery into the box, and make connections to its terminals as follows, using the two 12-inch (30 cm) Red and Black leads (equipped with FAST-ON connectors at one end) that have been supplied. See Diagram 1.

- a. Splice the wire end of the RED 12-inch lead to the Red lead (pin 23) coming from the 24-pin connector (an insulated solderless wire splice such as Ademco No. 311 may be used). Connect the other end (FAST-ON connector) of the 12-inch RED lead to the positive (+) terminal on the battery.
- b. Splice the wire end of the BLACK 12-inch lead to the Black lead (pin 10) coming from the 24-pin connector (be sure to use an insulated wire splice). Connect the other end (FAST-ON connector) of the 12-inch BLACK lead to the negative (-) terminal on the battery.

Note: For UL Listed usage, utilize the 4132-1 (optional) battery box cover. Feed the two battery wires through the two openings in the cover and insulate their connection to the battery with the plastic insulators supplied with the 4132-1. Insert the battery into the 4132 backbox and place the 4132-1 cover over the top of the battery.

4. Pull all interface wiring in the wall through the opening previously made. Splice the appropriate wires to the 24-pin interface connector as indicated in Diagram 1 (Summary of Connections) and in Table C previously. Insulated solderless wire splices (such as Ademco No. 311) may be used for splicing. **Check all wire connections carefully before splicing.**

Note: If the optional 15-ft (4.6 m) or 30-ft (9 m) wiring harness has been used for interface wiring, splices at the Control will not be necessary since these wiring harnesses are terminated with a 24-pin connector which can be connected directly to the 4130XT.

5. If a Remote Keypad is being used, splice the field wires in the wall to the wires on the 10-pin connector supplied for this purpose, **being sure to match wire colors.**

6. Attach the interface connector(s) to the Control board as follows, referring to Diagram 6:
 - a. Attach the 24-pin connector to the mating interfacing pins located at the bottom of the Control board.

- b. Attach the 10-pin connector (if a Remote keypad is being used) to the Remote Keypad connector (10-pin socket) at the top of the Control board via the "straight" male-to-male adapter supplied.

IMPORTANT: Be sure to orient the connector with BLACK lead (pin 1) to the left (when viewing the 4130XT from the rear), as indicated in Diagram 1.

7. On the Digital Communication interface board, attach the interconnecting wires to its terminal block as follows, referring also to Diagram 6:

Communication Interface Board Terminal	Wire Assignment
1	Ground Start *
2	Incoming Phone Line (Tip)
3	Incoming Phone Line (Ring)
4	Handset (Ring)
5	Handset (Tip)

*Connect to BLUE lead on 675 Ground Start Module.

Refer to Diagram 9 for Steps 8, 9 and 10:

8. Mount the Control as follows. Insert securing screw (previously removed) in screw hole at front of Control (see Diagram 7) and attach metal clip (at the rear) as shown in Diagram 9. Turn the screw until the clip enters the guide point about $\frac{1}{8}$ of an inch (3 mm).
9. Insert the straight end of the flat spring into the slot at the other side of the Control, as shown.
10. With the metal clip in the vertical position, mount the Control by hooking the spring behind the right edge of the opening so that it holds the Control against the inside of the wall, as shown at (A). Now turn the screw (from the front of the Control). The clip will turn until it hits the clip stop and will then draw the Control forward (B). Continue turning the screw until the Control is flush against the wall then, making sure that the Control is straight, tighten the screw further to secure the Control firmly in position. **DO NOT OVERTIGHTEN!**
11. Insert the small VISTA XT nameplate supplied into the recessed opening to cover the screw head at the front of the Control, as previously shown in Diagram 7.

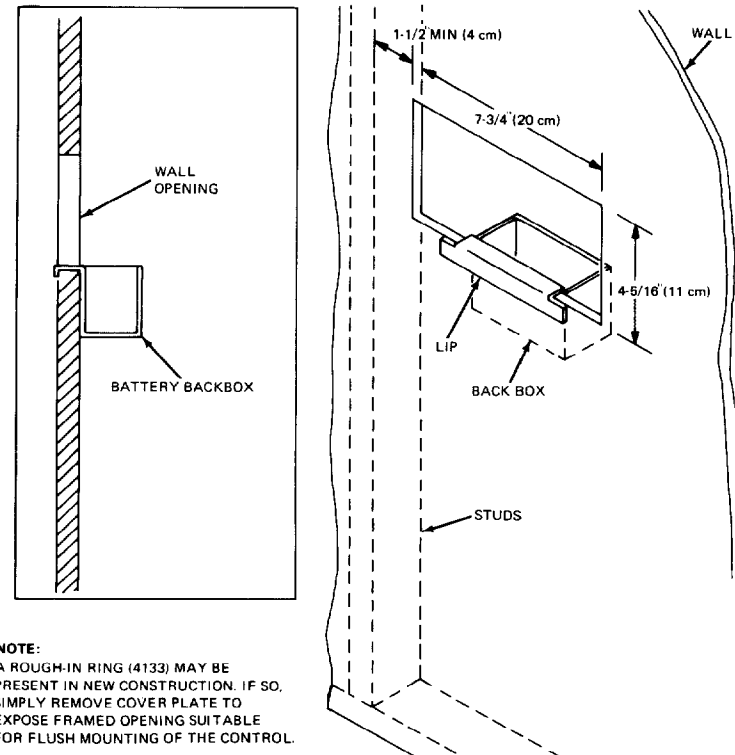
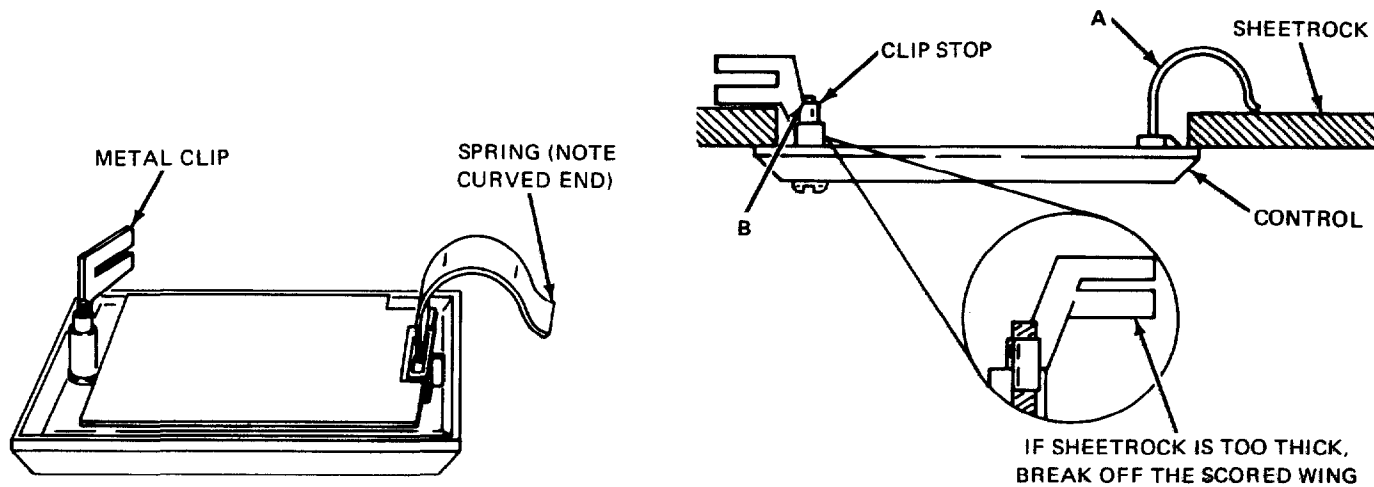

Diagram 8. WALL PREPARATION FOR FLUSH MOUNTING



NOTE:
 4-5/16" (11 cm) H X 7-3/4" (20 cm) W
 WALL OPENING IS REQUIRED FOR
 FLUSH MOUNTING.

Diagram 9. FLUSH MOUNTING THE 4130XT/4137/4147

PROGRAMMING THE SECURITY CONTROL

Installer options are stored in non-removable, electrically erasable, non-volatile EEPROM memory. These options must be programmed for the particular installation to establish its specific alarm and reporting features.

The security control may be programmed from its own keypad (the most convenient method) or from an optional 4137 or 4157 remote console, or can be programmed locally from the 699 Programmer. Information regarding the Programmer is included with the No. 695-30XT Programming Cartridge.

The system is factory-programmed to a set of preset values, which can be altered by the installer to suit the specific needs of a particular installation or installation company. The preset values are detailed in the Factory Programming Table.

Note: Programming information is stored in non-volatile EEPROM memory in this Control (removal of power will **not** result in the loss of the information). Consequently, it is possible to program the Control at any time — even at the installer's premises prior to the actual installation. Simply apply DC power temporarily to the Control and then program the unit as desired.

When programming from the Control, note the following:

1. Enter the Programming mode by simultaneously depressing the ***** and **#** keys within 30 seconds after power is applied to the Control, or subsequently by keying the code **4 + 1 + 3 + 0** followed by depression of **CODE + 0 + 0** keys. Once an installer code is programmed, use it instead of 4130 (as 4130 is no longer present) to gain access to the programming mode.

2. When a data field has been completely programmed, the Control will "beep" three times and then automatically proceed to, and display, the next data field address to be programmed.
3. If the number of digits that you enter in the data field is less than the maximum permitted (for example, phone number), then the Control will display the last data entered. To proceed, the next data field address to be programmed must then be entered (for example, ***05**).
4. If an address is improperly entered, the Control will display **FC**. If a program entry is improperly entered (for example, a larger number than that which is permitted), the Control display will go **blank**. In either case, simply re-enter the number.

The following is a description of commands necessary for programming:

FUNCTION

ENTER PROGRAMMING MODE:

PROCEDURE

1. POWER UP, then depress ***** and **#** simultaneously within 30 seconds of powering up.

OR

2. Initially, Key: **4 + 1 + 3 + 0** plus **CODE** key + **0 + 0**.

OR

3. After Installer Code is programmed, key: **Installer Code + CODE** key + **0 + 0**.

Notes: User #1 (installer) **must be enabled** (in Address 52) if Type 3 method of entry is to be used.

Type 3 method of re-entry to the programming mode is inhibited if the programming mode is exited via use of ***98**.

Type 1 method of entry can always be used unless console programming has been locked out by the remote downloader.

EXIT PROGRAMMING MODE: *99 (always allows re-entry to programming mode via Type 3 entry method above).
 *98 (inhibits re-entry to programming mode via Type 3 entry method).
Note: When the programming mode is exited, a 1-minute set-up period must elapse before the system can properly function.

ADVANCE TO FIELD: * + ADDRESS (e.g., 01, 10, 21, etc.).
 PROGRAM FIELD: * + ADDRESS, followed by data entries.
 ERASE FIELDS: ** + ADDRESS + * (only applies to Addresses 31 thru 34).
 READ FIELD: # + ADDRESS
 RESTORE FACTORY PROGRAM SETTINGS: *97 (see Factory Programming Table).

SPECIAL MESSAGES

OC = OPEN CIRCUIT (no communication between the Keypad and the Control, most relevant to 4137 or 4157 Remote Console).
FC = FIELD CODE ERROR (program entry mistake, re-enter the data).
 After powering up, READY will be displayed after approximately 7 seconds. Enter the programming mode by simultaneously depressing * and # within 30 seconds. The System is factory-programmed with preset values (see Table D) that can be altered via the programming instructions that follow the table.

FACTORY PRESET VALUES

Factory preset values serve two purposes:

- They can reduce programming time on the part of the installer if many of the preset values shown in the table are accepted.
- They will permit an installer who is unfamiliar with this product to quickly set up the system for bench test so that familiarity with the operation of the system can be achieved in a shorter period of time.

The factory preset values are defined in the Table that follows:

TABLE D. FACTORY PROGRAMMING

Address	Function	Factory Programmed Value	Address	Function	Factory Programmed Value
00	INSTALLER CODE	4 1 3 0			
01	MASTER SECURITY CODE	1 2 3 4			
02	ASSIGN RESPONSE TYPE FOR ZONES 1-8	Z1 0 9 Fire	03	ASSIGN RESPONSE TYPE FOR ZONES 9-16	Z9 0 0
		Z2 0 3 Perimeter, Burglary			Z10 0 0
		Z3 0 4 Interior, Follower, Burglary			Z11 0 0
		Z4 0 5 Trouble by Day/Alarm by Night, Burglary			Z12 0 0
		Z5 1 0 Interior, Delay, Burglary			Z13 0 0
		Z6 0 7 24-hour audible			Z14 0 0
		Z7 0 8 24-hour Aux			Z15 0 0
		Z8 0 1 Entry/Exit (Delay #1), Burglary	04	ASSIGN RESPONSE TYPE FOR ZONE 17	Z16 0 0
					Z17 0 0
					0 0
					0 0

Address	Function	Factory Programmed Value
		<input type="text" value="0"/> <input type="text" value="0"/>
		<input type="text" value="0"/> <input type="text" value="0"/>
		<input type="text" value="0"/> <input type="text" value="0"/>
		<input type="text" value="0"/> <input type="text" value="0"/>
		<input type="text" value="0"/> <input type="text" value="0"/>
05	ASSIGN RESPONSE TYPE FOR VARIOUS KEYPAD PANICS AND ZONE EXPANDER WIRING SUPERVISION	1 <input type="text" value="0"/> <input type="text" value="0"/>
		2 <input type="text" value="0"/> <input type="text" value="0"/>
		3 <input type="text" value="0"/> <input type="text" value="0"/>
		4 <input type="text" value="0"/> <input type="text" value="0"/>
		5 <input type="text" value="0"/> <input type="text" value="0"/> Short in Wiring to Zone Expander (displays "97")
		6 <input type="text" value="0"/> <input type="text" value="0"/> 1 and * Panic (displays "95")
		7 <input type="text" value="0"/> <input type="text" value="0"/> 3 and # Panic (displays "96")
		8 <input type="text" value="0"/> <input type="text" value="0"/> * and # Panic (displays "99")
06	DESIGNATE RIGHT ZONE USAGE	<input type="text" value="0"/> <input type="text" value="0"/> <input type="text" value="0"/> <input type="text" value="0"/> <input type="text" value="0"/> <input type="text" value="0"/> <input type="text" value="0"/> <input type="text" value="0"/> Zones 10-16 (none)

Address	Function	Factory Programmed Value
07	DESIGNATE RIGHT ZONE USAGE	<input type="text" value="0"/> Zone 17 (none)
08	NOT USED	
09	ENTRY DELAY #1	<input type="text" value="0"/> <input type="text" value="2"/> (30 seconds)
10	EXIT DELAY #1	<input type="text" value="0"/> <input type="text" value="3"/> (45 seconds)
11	ENTRY DELAY #2	<input type="text" value="0"/> <input type="text" value="6"/> (90 seconds)
12	EXIT DELAY #2	<input type="text" value="0"/> <input type="text" value="8"/> (120 seconds)
13	ALARM SOUNDER DURATION	<input type="text" value="0"/> <input type="text" value="4"/> (8 minutes)
14	ALARM SOUNDER SELECTION	<input type="text" value="0"/> (740/bell compatibility)
15	KEYSWITCH ARM/DISARM ENABLE	<input type="text" value="0"/> (Disable)
16	CONFIRMATION OF ARMING DING	<input type="text" value="0"/> (Disable)
17	AC POWER LOSS SOUNDING	<input type="text" value="0"/> (Disable)
18	NOT USED	<input type="text" value="0"/> (Entry of zero mandatory)
19	CONTROL ALARM SOUNDER DISABLE	<input type="text" value="0"/> (Enable)
20	NOT USED	<input type="text" value="0"/> (Entry of zero mandatory)

Address	Function	Factory Programmed Value
21	DISABLE FIRE TIME-OUT	0 (No)
22	FIRE INDICATION ON DISPLAY	1 (Enable)
23	MULTIPLE ALARMS	1 (Yes)
24	TAMPER DETECTION DISABLE (ZONES 10-17)	0 (Enable)
25	DURESS REPORT DISABLE (ADEMCO HIGH SPEED)	0 (Enable)
26	INTERNAL ALARM SOUND SELECTION	0 (Loud steady sound, UL Listed usage)
27	TEST REPORT INTERVAL	2 (24 hours)
28	POWER UP IN PREVIOUS STATE	1 (Yes)
29	QUICK ARM	1 (Enabled)
30	TOUCH-TONE OR ROTARY DIAL	1 (Touch-Tone)
31	PABX ACCESS CODE	No Entry
32	SUBSCRIBER ACCT NO.	1 5 1 5 1 5 1 5
33	PRIMARY PHONE No.	No Entry

Address	Function	Factory Programmed Value
34	SECONDARY PHONE No.	No Entry
35	CS DOWNLOAD PHONE No.	No Entry
36	CS ID No.	1 5 1 5 1 5 1 5 1 5 1 5 1 5 1 5
37	DOWNLOAD COMMAND ENABLES	1 1 Dialer Shutdown enabled 2 1 System Shutdown enabled 3 1 Not Used 4 1 Remote Bypass enabled 5 1 Remote Disarm enabled 6 1 Remote Arm enabled 7 1 Upload Program enabled 8 1 Download Program enabled
38	INHIBIT BYPASS OF ZONE	0 0 (All non-fire zones bypassable)

Address	Function	Factory Programmed Value	Address	Function	Factory Programmed Value
39	OPEN/CLOSE REPORTING ENABLE BY USER CODE	<input type="checkbox"/> <input type="checkbox"/> <input type="checkbox"/> <input type="checkbox"/> <input type="checkbox"/> <input type="checkbox"/> <input type="checkbox"/> <input type="checkbox"/> (disabled for Users 9-15)	50	SESCOA/RADIO-NICS SELECTION	<input type="checkbox"/> Radionics with B-F reporting
40	REPROGRAM/DOWNLOAD ATTEMPT REPORT	<input type="checkbox"/> <input type="checkbox"/> (No code reported)	51	DUAL REPORTING	<input type="checkbox"/> (No)
41	EOLR DISABLE (Zones 2-8)	<input type="checkbox"/> (End-of-Line Resistor supervision not required)	52	OPEN/CLOSE REPORTING ENABLE BY USER CODE	<input type="checkbox"/> <input type="checkbox"/> <input type="checkbox"/> <input type="checkbox"/> <input type="checkbox"/> <input type="checkbox"/> <input type="checkbox"/> <input type="checkbox"/> (disabled for Users 2-8)
42	DIAL TONE PAUSE	<input type="checkbox"/> (5 seconds)	53	4+2 ZONE EXPANDED FORMAT SELECTION	<input type="checkbox"/> (Not selected)
43	DIAL TONE DETECTION	<input type="checkbox"/> (Dial Tone Detection Enabled)	54	4+2 ZONE FORMAT SELECTION	<input type="checkbox"/> (Not selected)
44	RING DETECTION COUNT	<input type="checkbox"/> <input type="checkbox"/> (Ring detection disabled)	55	ALARM REPORT	<input type="checkbox"/> (Standard report)
45	PRIMARY ACK WAIT	<input type="checkbox"/> (30 seconds)	56	RESTORE REPORT	<input type="checkbox"/> (Expanded)
46	PRIMARY TRANSMISSION FORMAT	<input type="checkbox"/> (Ademco Low Speed)	57	BYPASS REPORT	<input type="checkbox"/> (Standard report)
47	SECONDARY ACK WAIT	<input type="checkbox"/> (30 seconds)	58	TROUBLE REPORT	<input type="checkbox"/> (Standard report)
48	SECONDARY TRANSMISSION FORMAT	<input type="checkbox"/> (Ademco Low Speed)	59	OPEN/CLOSE REPORT	<input type="checkbox"/> (Standard report)
49	SINGLE MESSAGE TRANSMISSION WITH CHECKSUM VERIFICATION	<input type="checkbox"/> (No)	60	LOW BATTERY, AC LOSS AND TEST REPORT	<input type="checkbox"/> (Standard report)

Address	Function	Factory Programmed Value
61	CHANNEL ASSIGNED TO EACH ZONE	1 <input type="text" value="0"/> <input type="text" value="0"/> Zeroes for zones 1-8 (no code reported) 2 <input type="text" value="0"/> <input type="text" value="0"/> 3 <input type="text" value="0"/> <input type="text" value="0"/> 4 <input type="text" value="0"/> <input type="text" value="0"/> 5 <input type="text" value="0"/> <input type="text" value="0"/> 6 <input type="text" value="0"/> <input type="text" value="0"/> 7 <input type="text" value="0"/> <input type="text" value="0"/> 8 <input type="text" value="0"/> <input type="text" value="0"/>
62	CHANNEL ASSIGNED TO EACH ZONE (CONTINUED)	1 <input type="text" value="0"/> <input type="text" value="0"/> Zeroes for zones 9-16 (no code reported) 2 <input type="text" value="0"/> <input type="text" value="0"/> 3 <input type="text" value="0"/> <input type="text" value="0"/> 4 <input type="text" value="0"/> <input type="text" value="0"/> 5 <input type="text" value="0"/> <input type="text" value="0"/>

Address	Function	Factory Programmed Value
63	CHANNEL ASSIGNED TO EACH ZONE (CONTINUED)	6 <input type="text" value="0"/> <input type="text" value="0"/> 7 <input type="text" value="0"/> <input type="text" value="0"/> 8 <input type="text" value="0"/> <input type="text" value="0"/> 1 <input type="text" value="0"/> <input type="text" value="0"/> Zone 17 2 <input type="text" value="0"/> <input type="text" value="0"/> All zeroes in 8 locations (same as Address *61) 3 <input type="text" value="0"/> <input type="text" value="0"/> 4 <input type="text" value="0"/> <input type="text" value="0"/> 5 <input type="text" value="0"/> <input type="text" value="0"/> 6 <input type="text" value="0"/> <input type="text" value="0"/> 7 <input type="text" value="0"/> <input type="text" value="0"/> 8 <input type="text" value="0"/> <input type="text" value="0"/>

Address	Function	Factory Programmed Value
64	CHANNELS ASSIGNED TO DURESS AND VARIOUS KEYPAD PANICS	1 <input type="text" value="0"/> <input type="text" value="0"/>
		2 <input type="text" value="0"/> <input type="text" value="0"/>
		3 <input type="text" value="0"/> <input type="text" value="0"/> All zeroes in 8 locations (same as Address *61)
		4 <input type="text" value="0"/> <input type="text" value="0"/> Duress
		5 <input type="text" value="0"/> <input type="text" value="0"/> Short on Wiring to Zone Expander (displays 97)
		6 <input type="text" value="0"/> <input type="text" value="0"/> 1 and * Panic (displays 95)
		7 <input type="text" value="0"/> <input type="text" value="0"/> 3 and # Panic (displays 96)
		8 <input type="text" value="0"/> <input type="text" value="0"/> * and # Panic (displays 99)
65	ALARM REPORTING CODES ASSIGNED TO EACH CHANNEL	1 <input type="text" value="0"/> <input type="text" value="0"/> Zeroes for channels 1-8 (no code reported)
		2 <input type="text" value="0"/> <input type="text" value="0"/>
		8 <input type="text" value="0"/> <input type="text" value="0"/>
		4 <input type="text" value="0"/> <input type="text" value="0"/>

Address	Function	Factory Programmed Value
66	ALARM REPORTING CODES ASSIGNED TO EACH CHANNEL (CONT'D)	5 <input type="text" value="0"/> <input type="text" value="0"/>
		6 <input type="text" value="0"/> <input type="text" value="0"/>
		7 <input type="text" value="0"/> <input type="text" value="0"/>
		8 <input type="text" value="0"/> <input type="text" value="0"/>
		9 <input type="text" value="0"/> <input type="text" value="0"/> Zeroes for channels 9-15 (no code reported)
		10 <input type="text" value="0"/> <input type="text" value="0"/>
		11 <input type="text" value="0"/> <input type="text" value="0"/>
		12 <input type="text" value="0"/> <input type="text" value="0"/>
		13 <input type="text" value="0"/> <input type="text" value="0"/>
		14 <input type="text" value="0"/> <input type="text" value="0"/>
		15 <input type="text" value="0"/> <input type="text" value="0"/>
		<input type="text" value="0"/> <input type="text" value="0"/>
		<input type="text" value="0"/> <input type="text" value="0"/>
		<input type="text" value="0"/> <input type="text" value="0"/>
		<input type="text" value="0"/> <input type="text" value="0"/> NOT USED

Address	Function	Factory Programmed Value	Address	Function	Factory Programmed Value
67	NON-ALARM CODES	<input type="checkbox"/> <input type="checkbox"/> All zeroes (no codes reported)	73	4 + 2 EXPANDED FORMAT ZONES 9-16 EVENT DIGIT (1st digit)	1 <input type="checkbox"/> <input type="checkbox"/> AL 2 <input type="checkbox"/> <input type="checkbox"/> TR 3 <input type="checkbox"/> <input type="checkbox"/> BY 4 <input type="checkbox"/> <input type="checkbox"/> AL RE 5 <input type="checkbox"/> <input type="checkbox"/> TR RE 6 <input type="checkbox"/> <input type="checkbox"/> BY RE Zeroes for zones 9-16 (no codes reported)
68	NON-ALARM CODES (CONT'D)	<input type="checkbox"/> <input type="checkbox"/> All zeroes (no codes reported)			
69	ZONE TYPES 1-4 RESTORE REPORT ENABLE	<input type="checkbox"/> <input type="checkbox"/> <input type="checkbox"/> <input type="checkbox"/> Enable (all)			
70	ZONE TYPES 5-8 RESTORE REPORT ENABLE	<input type="checkbox"/> <input type="checkbox"/> <input type="checkbox"/> <input type="checkbox"/> Zone 5 enabled, all others disabled			
71	ZONE TYPES 9 & 10 RESTORE REPORT ENABLE	<input type="checkbox"/> <input type="checkbox"/> Enabled (all)	74	4 + 2 EXPANDED FORMAT ZONE 17 EVENT DIGIT (1st digit)	1 <input type="checkbox"/> <input type="checkbox"/> AL 2 <input type="checkbox"/> <input type="checkbox"/> TR 3 <input type="checkbox"/> <input type="checkbox"/> BY 4 <input type="checkbox"/> <input type="checkbox"/> AL RE 5 <input type="checkbox"/> <input type="checkbox"/> TR RE 6 <input type="checkbox"/> <input type="checkbox"/> BY RE Zeroes for zone 17 (no codes reported)
72	4 + 2 EXPANDED FORMAT ZONES 1-8 EVENT DIGIT (1st digit)	1 <input type="checkbox"/> <input type="checkbox"/> AL 2 <input type="checkbox"/> <input type="checkbox"/> TR 3 <input type="checkbox"/> <input type="checkbox"/> BY 4 <input type="checkbox"/> <input type="checkbox"/> AL RE 5 <input type="checkbox"/> <input type="checkbox"/> TR RE 6 <input type="checkbox"/> <input type="checkbox"/> BY RE Zeroes for zones 1-8 (no codes reported)			

Address	Function	Factory Programmed Value	Address	Function	Factory Programmed Value		
75	4 + 2 EXPANDED FORMAT KEYPAD PANICS/ZONE EXPANDER WIRING SUPERVISORY EVENT DIGIT (1st digit)	1	<input type="text" value="0"/> <input type="text" value="0"/> AL	77	4 + 2 EXPANDED FORMAT ZONES 9-16 ID DIGIT (2nd digit)	9	<input type="text" value="0"/> <input type="text" value="0"/>
		2	<input type="text" value="0"/> <input type="text" value="0"/> TR			10	<input type="text" value="0"/> <input type="text" value="0"/>
		3	<input type="text" value="0"/> <input type="text" value="0"/> BY			11	<input type="text" value="0"/> <input type="text" value="0"/>
		4	<input type="text" value="0"/> <input type="text" value="0"/> AL RE			12	<input type="text" value="0"/> <input type="text" value="0"/>
		5	<input type="text" value="0"/> <input type="text" value="0"/> TR RE			13	<input type="text" value="0"/> <input type="text" value="0"/>
		6	<input type="text" value="0"/> <input type="text" value="0"/> BY RE			14	<input type="text" value="0"/> <input type="text" value="0"/> Zeroes for zones 9-16 (no codes reported)
76	4 + 2 EXPANDED FORMAT ZONES 1-8 ID DIGIT (2nd digit)	1	<input type="text" value="0"/> <input type="text" value="0"/>	15	<input type="text" value="0"/> <input type="text" value="0"/>		
		2	<input type="text" value="0"/> <input type="text" value="0"/>	16	<input type="text" value="0"/> <input type="text" value="0"/>		
		3	<input type="text" value="0"/> <input type="text" value="0"/> Zeroes for zones 1-8 (no codes reported)				
		4	<input type="text" value="0"/> <input type="text" value="0"/>				
		5	<input type="text" value="0"/> <input type="text" value="0"/>				
		6	<input type="text" value="0"/> <input type="text" value="0"/>				
		7	<input type="text" value="0"/> <input type="text" value="0"/>				
		8	<input type="text" value="0"/> <input type="text" value="0"/>				

Address	Function	Factory Programmed Value
78	4 + 2 EXPANDED 17 FORMAT_ZONE 17 ID DIGIT (2nd digit)	<input type="text" value="0"/> <input type="text" value="0"/>
		<input type="text" value="0"/> <input type="text" value="0"/>
		<input type="text" value="0"/> <input type="text" value="0"/>
		<input type="text" value="0"/> <input type="text" value="0"/> Zeroes for zone 17 and the other seven locations (no codes reported)
		<input type="text" value="0"/> <input type="text" value="0"/>
		<input type="text" value="0"/> <input type="text" value="0"/>
		<input type="text" value="0"/> <input type="text" value="0"/>
		<input type="text" value="0"/> <input type="text" value="0"/>
79	4 + 2 EXPANDED FORMAT_KEYPAD PANICS/ZONE EXPANDER WIRING SUPERVISORY ID DIGIT (2nd digit)	<input type="text" value="0"/> <input type="text" value="0"/>
		<input type="text" value="0"/> <input type="text" value="0"/>
		<input type="text" value="0"/> <input type="text" value="0"/>
		<input type="text" value="0"/> <input type="text" value="0"/> Duress
		<input type="text" value="0"/> <input type="text" value="0"/>

Address	Function	Factory Programmed Value
80	4 + 2 EXPANDED FORMAT_NON- ALARM CODES	<input type="text" value="0"/> <input type="text" value="0"/> Short in wiring to zone expander
		<input type="text" value="0"/> <input type="text" value="0"/> 1 & * Panic
		<input type="text" value="0"/> <input type="text" value="0"/> 3 & # Panic
		<input type="text" value="0"/> <input type="text" value="0"/> * & # Panic
		<input type="text" value="0"/> <input type="text" value="0"/> Zeroes (no codes reported) in all 10 locations
		<input type="text" value="0"/> <input type="text" value="0"/>
		<input type="text" value="0"/> <input type="text" value="0"/>
		<input type="text" value="0"/> <input type="text" value="0"/>
		<input type="text" value="0"/> <input type="text" value="0"/>
		<input type="text" value="0"/> <input type="text" value="0"/>
		<input type="text" value="0"/> <input type="text" value="0"/>
		<input type="text" value="0"/> <input type="text" value="0"/>
		<input type="text" value="0"/> <input type="text" value="0"/>

Address	Function	Factory Programmed Value	Address	Function	Factory Programmed Value
81	4 + 2 EXPANDED FORMAT NON- ALARM CODES (CONTINUED)	<input type="text" value="0"/> <input type="text" value="0"/> Zeroes (no codes reported) in all 10 locations <input type="text" value="0"/> <input type="text" value="0"/> <input type="text" value="0"/> <input type="text" value="0"/> <input type="text" value="0"/> <input type="text" value="0"/> <input type="text" value="0"/> <input type="text" value="0"/> <input type="text" value="0"/> <input type="text" value="0"/> <input type="text" value="0"/> <input type="text" value="0"/> <input type="text" value="0"/> <input type="text" value="0"/> <input type="text" value="0"/> <input type="text" value="0"/> <input type="text" value="0"/> <input type="text" value="0"/>	83	TEST REPORT INITIATION TIME	<input type="text" value="1"/> <input type="text" value="2"/> (12 hours)
			84	ADEMCO HIGH SPEED REPORT- ING ON 800/WATS LINES	<input type="text" value="0"/> (No)
			85	ENABLE 4130XT FOR SUBZONING	<input type="text" value="0"/> (Disabled)
			86	ZONE EXPANDER TYPE SELECTION	<input type="text" value="1"/> (4208 type selected)
82	ALARM COUNT	<input type="text" value="0"/> <input type="text" value="3"/> (Swinger Suppression)			

SPECIFIC ADDRESS PROGRAMMING INSTRUCTIONS

FUNCTION ADDRESS

INSTALLER CODE *00

COMMENTS: This 4-digit (0-9) code reserved for installation company use. Only active if openings and closings are enabled for User #1 (in Address *52). This is the only code that can be used to enter the Program mode from the Control. Cannot be used to enter secondary codes. This code may not be used if programming mode is exited by a ***98**.

MASTER SECURITY CODE *01

COMMENTS: Enter 4 digits, **0-9** (entry of all 4 is mandatory). Use of a **"9"** in last position inhibits the Ambush feature.

ASSIGN RESPONSE TYPES FOR ZONES 1-8 *02

Zone 1
 Zone 2
 Zone 3
 Zone 4
 Zone 4
 Zone 5
 Zone 6
 Zone 7*
 Zone 8

COMMENTS: Enter 2 digits, **00-10** in each field (use one of the response types below).

*If Zone 7 is to be used for Keypress Arm/Disarm operation, **10** must be entered as its response type.

00 = Assign for unused zones
 01 = ENTRY/EXIT (Delay #1), Burglary
 02 = ENTRY/EXIT (Delay #2), Burglary
 03 = PERIMETER, Burglary
 04 = INTERIOR, FOLLOWER, Burglary
 05 = TROUBLE BY DAY/ALARM BY NIGHT, Burglary
 06 = 24-HOUR SILENT
 07 = 24-HOUR AUDIBLE
 08 = 24-HOUR AUXILIARY
 09 = FIRE
 10 = INTERIOR, DELAY, Burglary

FUNCTION ADDRESS

**ASSIGN RESPONSE *03
TYPES FOR ZONES
9-16**

- 1 Zone 9
- 2 Zone 10
- 3 Zone 11
- 4 Zone 12
- 5 Zone 13
- 6 Zone 14
- 7 Zone 15
- 8 Zone 16

COMMENTS: Enter 2-digit response types
(see Address *02 for types)

**ASSIGN RESPONSE *04
TYPE FOR ZONE 17**

- 1 Zone 17
- 2
- 3
- 4 Zeroes to be entered
- 5
- 6

FUNCTION ADDRESS

**ASSIGN RESPONSE *05
TYPES FOR ZONE
EXPANDER WIRING
SUPERVISORY AND
FOR KEYPAD PANICS**

- 7 COMMENTS: Enter response type in field
- 8 location 1 (enter **00** in field locations 2-8).
- 1
- 2
- 3 Zeros to be entered
- 4
- 5 Short in Wiring to Zone Expander (displays **97**)
- 6 1 & * Panic (displays **95**)
- 7 3 & # Panic (displays **96**)
- 8 * & # Panic (displays **99**)

COMMENTS: Enter response types
(see Address * 02 for types)
in field locations 5-8 only
(enter **00** in fields 1-4).

FUNCTION ADDRESS

DESIGNATE RIGHT ZONE USAGE *06 10 11 12 13 14 15 16 Zones 10-16

*07 17 Zone 17

COMMENTS: All spaces must be filled with **0** or **1** (**1** if that zone is a right loop on a 4190WH transponder or on a 4196 Quad PIR transponder). When the 4208 is used as a Zone Expander, set all zone number locations to **0**. Similarly, set the zone number locations for 4194WH contact/transponders, 4192 smoke detector base/transponders, and 4275 Dual PIR transponders to **0**, as well as left loops on 4190WHs and the PIR portion of the 4196.

NOT USED *08

ENTRY DELAY #1 *09

COMMENTS: Defines the time period between a fault occurring in a zone to which Entry Delay #1 has been assigned and the time when the alarm will sound (UL 1023 Household Burglary usage permits a maximum of 45 seconds.) Applies to the Interior, Delay Zone type also. Enter **00 - 15**. Multiply by 15 seconds to determine time delay (0- 225 seconds available).

EXIT DELAY #1 *10

COMMENTS: Defines the time delay period after the system arming code is keyed when zone to which this delay has been assigned will arm (UL 1023 Household Burglary usage permits a maximum of 60 seconds). Is also the exit delay time allocated to the Interior zones (both Follower and Delay types). Enter **00 - 15**. Multiply by 15 seconds to determine time delay (0-225 seconds available).

FUNCTION ADDRESS

ENTRY DELAY #2 *11

COMMENTS: Defines the time period between a fault occurring in a zone to which Entry Delay #2 has been assigned and the time when the alarm will sound. (UL 1023 Household Burglary usage permits a maximum of 45 seconds.) **Must be set for longer period than Entry Delay #1 (in Address *09).**
Enter **00 - 15**. Multiply by 15 seconds to determine time delay (0-225 seconds available).

EXIT DELAY #2 *12

COMMENTS: Defines the time delay period after the system arming code is keyed when zone to which this delay has been assigned will arm. (UL 1023 Household Burglary usage permits a maximum of 60 seconds).
Must be set for longer period than Exit Delay #1 (in Address *10).
Enter **00 - 15**. Multiply by 15 seconds to determine time delay (0-225 seconds available).

ALARM SOUNDER DURATION *13

COMMENTS: Defines the length of time an external or the control's alarm sounder will sound on all audible alarms (UL 1023 Household Burglary usage requires a minimum of 4 minutes).
Enter **01 - 15**. Multiply by 2 minutes to determine sounder duration.

ALARM SOUNDER SELECTION *14

COMMENTS: Enter **0** for use with Ademco 740 or BRK BK-PA400B piezoelectric sounder, or AMSECO MSB-10G or ABB-1031 12V Motor Bell or for external relay activation. **Do not enter "1"**.

KEYSWITCH ARM/ DISARM ENABLE *15

COMMENTS: Requires the use of zone 7 wired loop (zone 7 no longer available as protection zone when used for keyswitch operation).
Enter **1** for keyswitch enable; otherwise, enter **0**. NOTE: **10** must have been entered for Zone 7 in Address *02.
Reports opening/closing by user #7 if reporting is enabled in Address *52.

FUNCTION	ADDRESS	
CONFIRMATION OF ARMING DING ENABLE	*16	<input type="checkbox"/> COMMENTS: Enter 1 to enable 1/2 second external alarm sounding at the end of exit delay #1 and 0 to disable the "ding".
AC POWER LOSS SOUNDING	*17	<input type="checkbox"/> COMMENTS: Enter 1 to enable this feature. Results in rapid beeping at Control when AC power is lost; otherwise, enter 0 .
NOT USED	*18	<input type="text" value="0"/> <input type="text" value="0"/> MUST BE ZERO
CONTROL ALARM SOUNDER DISABLE	*19	<input type="checkbox"/> COMMENTS: Enter 1 to disable the built-in sounder during a burglary; otherwise enter 0 .
NOT USED	*20	<input type="text" value="0"/> MUST BE ZERO
DISABLE FIRE TIME-OUT	*21	<input type="checkbox"/> COMMENTS: Disables the sounder time-out feature for any zone designated as a fire zone so that fire sounding continues until the system is reset (required for usage in accordance with UL985, Household Fire). Enter 0 (time-out) or 1 (no time-out).
FIRE INDICATION AT DISPLAY	*22	<input type="checkbox"/> COMMENTS: Enables a display of FIRE (or FI at 4157) whenever a fire alarm occurs. When the alarm is silenced or times out, the FI display at the 4157 is replaced by zone number. Enter 1 to enable; otherwise enter 0 (only zone number displayed).

FUNCTION	ADDRESS	
MULTIPLE ALARMS	*23	<input type="checkbox"/> COMMENTS: Enables the system to permit multiple audible alarms from a protection zone during one armed interval (as opposed to only one alarm). Enter 0 (only one alarm) or 1 (multiple alarms, but not more frequently than allowed by alarm time-out). Selection has no impact on the number of communication messages transmitted.
DISABLE TAMPER DETECTION IN EXPANSION ZONES 10-17	*24	<input type="checkbox"/> COMMENTS: Only applicable if No. 4190WH RPMs are used to provide expansion zones. Enter 1 to disable tamper detection (disables tamper detection in 4190WH or tamper detection is not applicable because other devices are used to provide expansion zones). Enter 0 to enable tamper detection (opening of the 4190WH case).
DISABLE DURESS REPORTING IN ADEMCO HIGH SPEED FORMAT	*25	<input type="checkbox"/> COMMENTS: Only applicable if Ademco High Speed Format is selected. Enter 1 to disable duress reporting or 0 to enable duress reporting.
INTERNAL ALARM SOUND SELECTION	*26	<input type="checkbox"/> COMMENTS: Enter 1 to select a "sweeping" sound (applicable only to non-UL usage) from the control's internal alarm sounder, enter 0 for a louder, steady sound (required for UL Listed usage). NOTE: Since remote Consoles can only produce a "steady" sound, program the control for steady tone (0) if they are used in the system.
TEST REPORT INTERVAL	*27	<input type="checkbox"/> COMMENTS: Determines time period between test reports. Enter 0 (no report), or 1 (12 hours), 2 (24 hours) or 3 (168 hours). Must be used in conjunction with Data Fields *83 and *68 (location 5). Select a non-zero entry if automatic low battery testing under load is desired.

FUNCTION ADDRESS

**POWER UP IN
PREVIOUS STATE**

***28**

COMMENTS: If selected (YES), on power-up the system will assume system status prior to power down. If not selected (NO), the system will power up in disarmed state.

Enter **0** (NO) or **1** (YES).

When the system powers up armed, an alarm will occur 3 minutes after arming if a zone is faulted. When so armed, reports closing as User #7 if open/close reporting for User #7 was enabled in Address *52.

QUICK ARM

***29**

COMMENTS: Enables arming of the burglary system in any mode without use of a Security Code (just # key depression followed by the command AWAY, STAY, INSTANT or MAXIMUM). When armed AWAY or MAXIMUM, reports closing as User #7 if open/close reporting for User #7 was enabled in Address *52.

Enter **0** (disabled) or **1** (enabled).

**TOUCH-TONE OR
ROTARY DIAL**

***30**

COMMENTS: Permits selection of the type of dialing to be used.

Enter **1** for Touch-Tone, **0** for Rotary.

PABX ACCESS CODE *31

COMMENTS: If not required, enter nothing and proceed to next address; otherwise, enter prefix needed to obtain an outside Telco line. This field may be used alternatively to enter a prefix that can suppress the Telco's call waiting feature from interfering with outgoing transmission. This prefix is only useful if the Telco option to be able to suppress call waiting has been obtained by your customer. The prefix to be used is 1170 if pulse dialing is being used or *70 if TouchTone® dialing is being used.

Enter up to 4 digits. Each digit requires a 2-digit entry so as to allow entry of hexadecimal digits (B-F). Use the following chart to determine the entry for each digit. Only enter digits required. Do not fill unused spaces. Erase the field by entering *31*.

FUNCTION ADDRESS

NUMBER	ENTER	NUMBER	ENTER
0	00	8	08
1	01	9	09
2	02	A	(Do Not Use)
3	03	B	11
4	04	C	12
5	05	D	13
6	06	E	14
7	07	F	15

SUBSCRIBER ACCT. NO. *32

COMMENTS: Enter 3 or 4 digits. Each digit requires a 2-digit entry so as to allow entry of hexadecimal digits (B-F). If entry consists of only 3 digits, enter data in the first 6 locations, leaving the last two unfilled. Use the chart in address *31 to determine the entry for each digit. Erase the field by entering ***32***

PRIMARY PHONE No. *33

COMMENTS: Enter up to 12 digits, **0-9**. Do not fill unused spaces. Erase the field by entering ***33***. NOTE: Back-up reporting (8 calls are made to the secondary phone number if no acknowledgment is received after 8 attempts to the primary number) is automatic only if there is a secondary phone number

SECONDARY PHONE No. *34

COMMENTS: Enter up to 12 digits, **0-9**. Do not fill unused spaces. Erase the field by entering ***34***.

CENTRAL STATION DOWNLOAD PHONE No. *35

COMMENTS: Only applicable if downloading will be utilized. Enter up to 12 digits, **0-9**. Do not fill unused spaces. Erase the field by entering ***35***

CENTRAL STATION ID NUMBER *36

COMMENTS: Only applicable if downloading will be utilized. Enter all 8 hexadecimal digits. (**0-9, A-F**).

00 = 0	02 = 2	04 = 4	06 = 6	08 = 8	10 = A	12 = C	14 = E
01 = 1	03 = 3	05 = 5	07 = 7	09 = 9	11 = B	13 = D	15 = F

FUNCTION ADDRESS

**DOWNLOAD
COMMAND ENABLES *37**

- 1 Dialer Shutdown
- 2 System Shutdown
- 3 0 Not Used
- 4 Remote Bypass
- 5 Remote Disarm
- 6 Remote Arm
- 7 Upload Program
- 8 Download Program

COMMENTS: Each of the various remote (from the Central Station) functions can either be enabled or disabled, dependent upon what functions the Central Station desires to perform. Setting a function to be disabled means that the Central Station will not be able to perform this function in the system. Enter **1** to enable a function and **0** to disable a function.

**INHIBIT BYPASS
OF ZONE *38**

COMMENTS: Enables one zone to be selected as a priority zone which cannot be bypassed. Enter 2 digits (for zone number) **01-17**. Enter **00** if all zones to be bypassable. This section has no impact on fire zones, which are always non-bypassable.

FUNCTION ADDRESS

OPEN/CLOSE REPORTING ENABLE BY USER CODE *39	<input type="checkbox"/> 9 <input type="checkbox"/> 10 <input type="checkbox"/> 11 <input type="checkbox"/> 12 <input type="checkbox"/> 13 <input type="checkbox"/> 14 <input type="checkbox"/> 15
	COMMENTS: Enter 0 (disable) or 1 (enable). Determines which user codes will send open/close reports.
REPORTING CODE FOR ATTEMPT (SUCCESSFUL OR UNSUCCESSFUL) BY A REMOTE AGENCY TO GET INTO A DOWNLOAD MODE WITH THE SYSTEM OR FOR SOMEONE TO LOCALLY CHANGE THE PROGRAM *40	<input type="checkbox"/> <input type="checkbox"/> LOCAL REPROGRAM/DOWNLOAD ATTEMPT REPORT (1st digit)
	COMMENTS: Applicable if downloading will be utilized or not. Enter reporting code as double digits. Disable = 00 (no code reporting). 01 = 1 06 = 6 11 = B 02 = 2 07 = 7 12 = C 03 = 3 08 = 8 13 = D 04 = 4 09 = 9 14 = E 05 = 5 10 = 0 15 = F
	Note: If 4+2 by point reporting is being used, the second digit is the second digit of the power up code.
DISABLE USAGE OF END-OF-LINE RESISTOR SUPERVISION ON WIRED ZONES 2-8 *41	<input type="checkbox"/>
	COMMENTS: Enter 1 to change zones 2-8 to N.C. loops that detect only an "open" and do not require end-of-line resistors (EOLRs). Enter 0 to retain EOLR supervision of zones 2-8.
DIAL TONE PAUSE *42	<input type="checkbox"/>
	COMMENTS: This feature determines the wait time for dial tone detection before dialing will commence if detection does not take place. Enter single digit, 0 (5 seconds), 1 (11 seconds) or 2 (30 seconds.)

FUNCTION ADDRESS

**DIAL TONE
DETECTION**

***43**

COMMENTS: Determines whether true dial tone detection is used, or whether just delay before dialing (same as programmed in Address *42) is used. The latter may be necessary in high-noise environment Telco networks where noise can be confused with dial tone and premature dialing results.
Enter **1** (Dial Tone Detection) or **0** (Dial Tone Detection disable).

**RING DETECTION
COUNT**

***44**

COMMENTS: Only applicable if central station initiated downloading will be used. Enter **00** to disable ring detection. Enter **01-14** for ring counts of 1-14. Enter **15** to select mode that gets around telephone answering machines connected to the same phone line. In the latter mode, the system upon hearing **one** ring followed by nothing, will not answer but will ready itself to pick up the **next** incoming call received within the next 30 seconds on the **first** ring (the downloader calling again).

PRIMARY ACK WAIT *45

COMMENTS: Central Station receiver "Acknowledge" wait time for primary phone number.
Enter **0** (30 seconds) or **1** (60 seconds).

**PRIMARY
TRANSMISSION
FORMAT**

***46**

COMMENTS: Permits selection between Ademco Low Speed format, SESCOA/Radionics, or Ademco High Speed format.

Enter **0** (Ademco Low Speed) or **1** (SESCOA/Radionics), or **2** [Ademco High Speed - Traditional for up to 14 (all 20 if non-unique reporting is acceptable) zones plus duress and 4+2 DTMF for all 21 zones].

Note: If Traditional Ademco High Speed reporting is selected, the Non-Alarm reports desired must be selected in Addresses *40, *67 and *68 and the alarm reports desired must be selected in Addresses *65 and *66. (Any non-zero code may be used).

**SECONDARY ACK
WAIT**

***47**

COMMENTS: Central Station receiver "Acknowledge" wait time for secondary phone number.
Enter **0** (30 seconds) or **1** (60 seconds).

FUNCTION ADDRESS

SECONDARY TRANSMISSION FORMAT *48

COMMENTS: Same options as Address *46.
Enter **0** (Ademco Low Speed **1** (SESCOA/Radionics), or **2** (Ademco High Speed).

SINGLE MESSAGE TRANSMISSION WITH CHECKSUM VERIFICATION *49

COMMENTS: When selected, will send verification digit with the message to validate the message at the receiver without having to send two message rounds. Enter **0** (NO) or **1** (YES).
NOTE: Selection applies to both primary and secondary phone numbers.

SESCOA/RADIONICS SELECTION *50

COMMENTS: Enter **0** if Radionics format is to be used with hexadecimal B-F reporting; enter **1** if SESCOA format is to be used with only numeric reporting (0-9).
NOTE: Selection applies to both primary and secondary phone numbers.

DUAL REPORTING *51

COMMENTS: If selected, will send all reports to both primary and secondary phone numbers.
NOTE: If dual reporting is desired and Ademco High Speed format is to be used at all, it must be selected as both the primary and secondary transmission formats.
Enter **0** (NO) or **1** (YES)

OPEN/CLOSE REPORTING ENABLE BY USER CODE *52

1 2 3 4 5 6 7 8

COMMENTS: Enter **0** (disable) or **1** (enable) Determines which user code will send open/close reports. User #7 must be enabled if open/close reporting is desired for keyswitch arming or close reporting is desired for "Quick Arm" and "Power Up" arm.

NOTE: User #1 must be enabled to permit use of installer code to enter programming mode.

FUNCTION ADDRESS

**4+2 ZONE (MAX. OF
17 WIRED ZONES)
EXPANDED FORMAT
SELECTION** *53

COMMENTS: Enter **1** if 4+2 reporting by zone for a zone expanded system is desired, enter **0** if a non expanded zone configuration is being used. If the expanded zone reporting format is selected, skip Addresses 55-71 and continue programming at Address #72.

IMPORTANT: If Ademco High Speed format had been selected in Addresses *46 or *48 **and** this selection is made, a high speed 4+2 transmission using DTMF TouchTone® communication can be obtained which is compatible with Ademco No. 685 Digital Receivers using Level **4.3** software or higher.

**4+2 ZONE (MAX. OF 9
WIRED ZONES)
FORMAT SELECTION** *54

COMMENTS: Enter **1** if 4+2 reporting is desired, enter **0** if 3+1/4+1 or traditional Ademco High Speed reporting is to be used. This selection is overridden by the selection of 4+2 reporting in Address *53. If the 4+2 format of address *54 is selected, Addresses 55-70 should be programmed, but Addresses 72 through 81 should be skipped.

The following reports (Addresses *55 - * 60) may be designated to report either in Standard or Expanded format. In all cases, the Standard message reports to the Central Station a subscriber ID number and a report [e.g., alarm (see Address *55), trouble, restore, open/close] code. The Expanded message reports a subscriber ID number, the report code, followed by a second line where the report code is repeated three or four times and is trailed by the channel number (or user ID) related to that report. When 4+2 format is selected, no second line is transmitted. The channel number or User ID is sent as the last digit of the report.

Report	3+1/4+1 Standard	3+1/4+1 Expanded	4+2	Report	3+1/4+1 Standard	3+1/4+1 Expanded	4+2
Alarm	SSS(S) A	SSS(S) A AAA(A) C _h	SSSS AC _h	AC Loss	SSS(S) R	SSS(S) R RRR(R) A _C	SSSS RA _C
Trouble	SSS(S) T	SSS(S) T TTT(T) C _h	SSSS TC _h	Low Battery	SSS(S) R	SSS(S) R RRR(R) L _B	SSSS RL _B
Bypass	SSS(S) B	SSS(S) B BBB(B) C _h	SSSS BC _h	Trouble	SSS(S) R _T	S S S (S) R _T R _T R _T R _T (R _T)C _h	SSSS R _T C _h
AC Loss	SSS(S) E	SSS(S) E EEE(E) A _C	SSSS EA _C	Bypass	SSS(S) R _B	S S S (S) R _B R _B R _B R _B (R _B)C _h	SSSS R _B C _h
Low Battery	SSS(S) L	SSS(S) L LLL(L) L _B	SSSS LL _B	Where:			
Open	SSS(S) O	SSS(S) O OOO(O) U	SSSS OU	SSS or SSSS = Subscriber ID	L = Low Battery Code (1st digit)		
Close	SSS(S) C	SSS(S) C CCC(C) U	SSSS CU	A = Alarm Code	L _B = Low Battery Code (2nd digit)		
Cancel	SSS(S) X	SSS(S) X	SSSS X0	0 = Zero	O = Open Code		
Test	SSS(S) T _e	SSS(S) T _e	SSSS T _e 0	C _h = Channel Number	C = Close Code		
Power Up Reset	SSS(S) P	SSS(S) P	SSSS P0	T = Trouble Code	U = User Number		
Program Tamper	SSS(S) M	SSS(S) M	SSSS M0	B = Bypass Code	T _e = Test Code		
Restore:				E = AC Loss Code (1st Digit)	R = Restore Code (Alarm, AC Loss, Low Battery)		
Alarm	SSS(S) R	SSS(S) R RRR(R) C _h	SSSS RC _h	A _C = AC Loss Code (2nd digit)	R _T = Restore Code (Trouble)		
				X = Cancel Code	R _B = Restore Code (Bypass)		
				P = Power Up Reset Code			
				M = Program Tamper Code			

Ademco High Speed Format

This format is the fastest format used in the alarm industry in that alarm information on **8** zones can be received at a Central Station in 5 seconds. This format utilizes DTMF (TouchTone®) signalling and transmits at the rate of 10 hexadecimal **characters** per second. The traditional format of Ademco High Speed transmission contains 13 digits, as follows: 4 digit Subscriber ID number, 8 digits containing the status of each of 8 event reporting channels and 1 digit in a 9th channel that is primarily used to indicate what kind of event is being received in the other 8 channels.

For the eight event reporting channels (digits 5-12 in the format), the channel status codes are as follows:

Code	Meaning
------	---------

1	NEW EVENT (previously unreported)
2	OPENING REPORT
3	RESTORE
4	CLOSING REPORT
5	NORMAL (no event since previously reported RESTORE)
6	PREVIOUSLY REPORTED EVENT STILL PRESENT

For the ninth channel (digit 13), the following channel status codes are used:

- 1 DURESS REPORT in channel 1 and ZONE ALARM and ALARM RESTORES assigned to CHANNELS 9 through 15 (in Addresses *61 through *64) will appear in channels 2 through 7 respectively. Channel 8 is not usable.
- 2 OPENING REPORT in the previous 7 or 8 channels; 7 if expanded opening/closing reporting is selected, wherein User ID (1-9, A-F) appears in Channel 1.
- 3 BYPASS and BYPASS RESTORE REPORTS for ZONES assigned to CHANNELS 1 through 8 (in Addresses *61 through *64) will appear in Channels 1 through 8.

- 4 CLOSING REPORT in the previous 7 or 8 channels; 7 if expanded opening/closing reporting is selected, wherein User ID (1-9, A-F) appears in Channel 1.
- 5 ZONE TROUBLE and TROUBLE RESTORE REPORTS for ZONES assigned to CHANNELS 1 through 8 (in Addresses *61 through *64) will appear in channels 1 through 8.
- 6 SYSTEM TROUBLE and TROUBLE RESTORE REPORTS are in the previous 8 channels; wherein:

CH 1 = Loss of AC	CH 5 = Not Applicable
CH 2 = Low Battery	CH 6 = Not Applicable
CH 3 = Program Tamper*	CH 7 = Not Applicable
CH 4 = Power On Reset*	CH 8 = Not Applicable

*No Restore report is provided for these conditions.

- 7 ZONE ALARM and ALARM RESTORE REPORTS for ZONES assigned to CHANNELS 1 through 8 (in Addresses *61 through *64) will appear in channels 1 through 8.
- 9 TEST REPORT. All '5's will appear in channels 1 through 8.

IMPORTANT NOTES:

1. When the traditional Ademco High Speed format is used, zones assigned to channels 9 through 15 in Addresses *61 through *64 **cannot** report trouble, trouble restore, bypass, and bypass restore. As such, 24 hour type keypad panic zones are good candidates for the use of these reporting channels (e.g. * & #, 1 & *, 3 & # panics, etc...)
2. Only NEW events: ALARM, OPENING, RESTORE, BYPASS, CLOSING or TROUBLE on any channel or TEST will trigger transmission, at which time all 9 channels will report.
3. When the traditional Ademco High Speed format is used, non-zero codes **must** be entered in Addresses 61, 62, 63, 64 (for zones in use), 65, 66, 67, 68.

Examples (Ademco High Speed Zone format)

1. At subscriber #5890, channels 2 and 5 go into alarm (and initiate a call) and channel 6, which has previously reported an alarm is still triggered.

	Subscriber Identification	Channel Number
	1 2 3 4	5 6 7 8 9
Message:	5 8 9 0	5 1 5 5 1 6 5 5 7
	Channel 2:	NEW ALARM
	Channel 5:	NEW ALARM
	Channel 6:	PREVIOUSLY REPORTED ALARM (still in effect)

2. Still at subscriber #5890, following the events of example 1 above, channel 2 restores (initiating the call) and channels 5 and 6 remain in alarm:

	Subscriber Identification	Channel Number
	1 2 3 4	5 6 7 8 9
Message:	5 8 9 0	5 3 5 5 6 6 5 5 7
	Channel 2:	NEW RESTORE
	Channels 5, 6:	PREVIOUSLY REPORTED ALARMS (still in effect)

3. Subscriber #0135 sends an opening:

	Subscriber Identification	Channel Number
	1 2 3 4	5 6 7 8 9
Message:	0 1 3 5	1 2 2 2 2 2 2 2 2
	Channel 1:	USER ID — User #1 opened
	Channels 2-9:	OPENING REPORT TRANSMITTED

4. After transmission of Example 3, subscriber #0135 sends a closing:

	Subscriber Identification	Channel Number
	1 2 3 4	5 6 7 8 9
Message:	0 1 3 5	D 4 4 4 4 4 4 4 4
	Channel 1:	USER ID - User #13 (= hex D) closed
	Channels 2-9:	CLOSING REPORT TRANSMITTED

5. Subscriber #0135 sends a duress message:

	Subscriber Identification	Channel Number
	1 2 3 4	5 6 7 8 9
	0 1 3 5	1 5 5 5 5 5 5 5 1
	Channel 1:	DURESS REPORT
	Channel 9:	SUPPLEMENTAL ALARM ZONES TRANSMITTED

6. Subscriber #0135 User #7 bypasses faulted zone 2 (for the sake of this example, Zone 2 = Channel 3, not a requisite) and then arms the system.

	Subscriber Identification	Channel Number
	1 2 3 4	5 6 7 8 9
Message:	0 1 3 5	5 5 1 5 5 5 5 5 3 (Bypass Report)
	0 1 3 5	7 4 4 4 4 4 4 4 4 (Closing Report)
Bypass restorals are transmitted when the restoral takes place.		
	0 1 3 5	5 5 3 5 5 5 5 5 3

7. If a trouble condition occurs in Zone 4 for subscriber #5890 and Zone 4 was assigned to Channel 2, a trouble report is transmitted.

	Subscriber Identification	Channel Number 1 2 3 4 5 6 7 8 9
Message:	5 8 9 0	5 1 5 5 5 5 5 5 6
Trouble restoral is transmitted as soon as it occurs.		
	5 8 9 0	5 3 5 5 5 5 5 5 6

8. If a system trouble condition occurs, a separate trouble message format exists.

	Subscriber Identification	Channel Number 1 2 3 4 5 6 7 8 9
For Loss of AC Reporting (Channel 1 is used)		
Message:	0 1 3 5	1 5 5 5 5 5 5 5 6
For AC Restoral		
Message:	0 1 3 5	3 5 5 5 5 5 5 5 6
For Low Battery Reporting (Channel 2 is used)*		
Message:	0 1 3 5	5 1 5 5 5 5 5 5 6

*Low battery is not only determined when AC power is off and the battery is being discharged. It is also tested for by periodically (at the interval selected in Address #27) removing AC power briefly to check battery status.

For Low Battery Restoral

Message: 0 1 3 5 5 3 5 5 5 5 5 6

For Program Tamper (Channel 3 is used)

Message: 0 1 3 5 5 5 1 5 5 5 5 6

For Power Up Reset (Channel 4 is used)

Message: 0 1 3 5 5 5 5 1 5 5 5 6

NOTE: Restorals are not applicable to Program Tamper and Power Up Reset.

9. At Subscriber #5890, Zone 12 assigned to channel 13 goes into alarm and Zone 11 assigned to channel 11, which has previously reported an alarm has restored.

	Subscriber Identification	Channel Number 1 2 3 4 5 6 7 8 9
Message:	5 8 9 0	5 5 5 3 5 1 5 5 1

10. At Subscriber #0135 a test message is initiated.

	Subscriber Identification	Channel Number 1 2 3 4 5 6 7 8 9
Message:	0 1 3 5	5 5 5 5 5 5 5 5 9

FUNCTION	ADDRESS	<input type="checkbox"/>
ALARM REPORT	*55	

COMMENTS: Enter **0** (Standard Report) or **1** (Expanded Report).
When Expanded is selected, the channel number is transmitted in the last position of the 2nd transmission line (or of the 1st transmission line if 4+2 Format is used).
NOTE: Selection applies to both primary and secondary phone numbers.

FUNCTION ADDRESS

RESTORE REPORT *56

COMMENTS: Enter **0** (Standard Report) or **1** (Expanded Report).
When a zone of protection alarm, bypass or trouble report is transmitted, a restore report for any of those conditions is not issued unless **ALL** like conditions within a zone are restored.
When Expanded is selected, the channel number is transmitted in the last position of the 2nd transmission line (of the 1st transmission line if 4+2 Format is used). Restore reports for each **zone type** alarm are individually selectable (see Address numbers *69 through *71).
NOTE: Selection applies to both primary and secondary phone numbers.

BYPASS REPORT *57

COMMENTS: Enter **0** (Standard Report) or **1** (Expanded Report).
Bypassing a zone results in a bypass report and in a restore report when all bypasses are removed.
Fire and priority zones cannot be bypassed. When Expanded is selected, the channel is transmitted in the last position of the 2nd transmission line (or of the last transmission line if 4+2 Format is used). Zone ID is not transmitted.
NOTE: Selection applies to both primary and secondary phone numbers.

TROUBLE REPORT *58

COMMENTS: Enter **0** (Standard Report) or **1** (Expanded Report).
When Expanded is selected, the channel is transmitted in the last position of the 2nd transmission line (or of the 1st transmission line if 4+2 Format is used). Zone ID is not transmitted.
NOTE: Selection applies to both primary and secondary phone numbers.

OPEN/CLOSE REPORT *59

COMMENTS: Enter **0** (Standard Report) or **1** (Expanded Report).
When Expanded is selected, user ID (1-9, A-F) is transmitted in the last position of the 2nd transmission line (or of the 1st transmission line if 4+2 Format is used).
NOTE: Selection applies to both primary and secondary phone numbers.

FUNCTION ADDRESS

**LOW BATTERY,
AC LOSS AND
TEST REPORT**

***60**

COMMENTS: Enter **0** (Standard Report) or **1** (Expanded Report).
When Expanded is selected, an additional programmable code is transmitted in the last position of the 2nd transmission line (of the 1st transmission line if 4+2 Format is used).
NOTE: Selection applies to both primary and secondary phone numbers.

**CHANNEL ASSIGNED *61
TO EACH ZONE**

***61**

- 1 Zone 1
- 2 Zone 2
- 3 Zone 3
- 4 Zone 4
- 5 Zone 5
- 6 Zone 6
- 7 Zone 7
- 8 Zone 8

NOTE: Channel 9 (09) is reserved for duress reporting when that function is enabled in Address *25.

COMMENTS: Enter all channel IDs as double digits.
Disable = **00** (no channel reporting)

01 = 1 06 = 6 11 = B
 02 = 2 07 = 7 12 = C
 03 = 3 08 = 8 13 = D
 04 = 4 09 = 9 14 = E
 05 = 5 10 = 0 15 = F

FUNCTION ADDRESS

**CHANNEL ASSIGNED *62
TO EACH ZONE (CONT'D)**

***62**

- 1 Zone 9
- 2 Zone 10
- 3 Zone 11
- 4 Zone 12
- 5 Zone 13
- 6 Zone 14
- 7 Zone 15
- 8 Zone 16

COMMENTS: Enter all channel IDs as double digits (same as Address *61). Disable = **00** (no channel reporting).

NOTE: Channel 9 (09) is reserved for duress reporting when that function is enabled in Address *25.

FUNCTION ADDRESS

**CHANNEL ASSIGNED *63
TO EACH ZONE
(CONT'D)**

- 1 Zone 17
- 2 Not Used
- 3 Not used
- 4 Not Used
- 5 Not used
- 6 Not used
- 7 Not used
- 8 Not used

COMMENTS: Enter all channel IDs as double digits (same as Address *61).
Disable = **00** (no channel reporting).
NOTE: Channel 9 (09) is reserved for duress reporting when that function is enabled in Address *25.

FUNCTION ADDRESS

**CHANNEL ASSIGNED *64
TO EACH ZONE
(CONT'D)**

- 1 Not used
- 2 Not used
- 3 Not used
- 4 Duress
- 5 Short on Wiring to Zone Expander
- 6 **1 & *** Panic
- 7 **3 & #** Panic
- 8 *** & #** Panic

COMMENTS: Enter all channel IDs as double digits (same as Address *61).
Disable = **00** (no channel reporting).
Non-zero codes **must** be entered when traditional Ademco High Speed format is used.
NOTE: Channel 9 (09) is reserved for duress reporting when that function is enabled in Address *25.

FUNCTION ADDRESS

**ALARM REPORTING
CODES ASSIGNED
TO EACH CHANNEL**

***65**

1	<input type="text"/>	<input type="text"/>
2	<input type="text"/>	<input type="text"/>
3	<input type="text"/>	<input type="text"/>
4	<input type="text"/>	<input type="text"/>
5	<input type="text"/>	<input type="text"/>
6	<input type="text"/>	<input type="text"/>
7	<input type="text"/>	<input type="text"/>
8	<input type="text"/>	<input type="text"/>

COMMENTS: Enter all alarm reporting codes as double digits.
Disable = **00** (no code reporting).
Note: Non-zero codes **must** be entered when traditional Ademco High Speed format is used

01 = 1 06 = 6 11 = B
02 = 2 07 = 7 12 = C
03 = 3 08 = 8 13 = D
04 = 4 09 = 9 14 = E
05 = 5 10 = 0 15 = F

FUNCTION ADDRESS

**ALARM REPORTING
CODES ASSIGNED
TO EACH CHANNEL
(CONT'D)**

***66**

9	<input type="text"/>	<input type="text"/>
10	<input type="text"/>	<input type="text"/>
11	<input type="text"/>	<input type="text"/>
12	<input type="text"/>	<input type="text"/>
13	<input type="text"/>	<input type="text"/>
14	<input type="text"/>	<input type="text"/>
15	<input type="text"/>	<input type="text"/>
16	<input type="text"/>	<input type="text"/>

COMMENTS: Enter all alarm reporting codes as double digits (same as Address *65).
Disable = **00** (no code reporting).
Note: Non-zero codes **must** be entered when traditional Ademco High Speed format is used.

FUNCTION	ADDRESS	
NON-ALARM CODES	*67	
		<input type="checkbox"/> <input type="checkbox"/> AC LOSS
		<input type="checkbox"/> <input type="checkbox"/> AC LOSS 2ND DIGIT
		<input type="checkbox"/> <input type="checkbox"/> TROUBLE
		<input type="checkbox"/> <input type="checkbox"/> TROUBLE RESTORE
		<input type="checkbox"/> <input type="checkbox"/> BYPASS
		<input type="checkbox"/> <input type="checkbox"/> BYPASS RESTORE
		<input type="checkbox"/> <input type="checkbox"/> RESTORE CODE FOR ALARM, AC LOSS, LOW BATTERY
		COMMENTS: Enter all codes as double digits (same as Address *65). Disable = 00 (no report). Note: Non-zero codes must be entered when traditional Ademco High Speed format is used.
NON-ALARM CODES	*68	
		<input type="checkbox"/> <input type="checkbox"/> OPEN
		<input type="checkbox"/> <input type="checkbox"/> CLOSE

FUNCTION	ADDRESS	
*68 (CONT'D)		
		<input type="checkbox"/> <input type="checkbox"/> LOW BATTERY
		<input type="checkbox"/> <input type="checkbox"/> LOW BATTERY 2ND DIGIT
		<input type="checkbox"/> <input type="checkbox"/> *TEST
		<input type="checkbox"/> <input type="checkbox"/> *POWER UP ¹
		<input type="checkbox"/> <input type="checkbox"/> NOT USED
		<input type="checkbox"/> <input type="checkbox"/> *CANCEL CODE ²

COMMENTS: Enter all codes as double digits (same as Address *65).
Disable = **00** (no report).
Note: Non-zero codes **must** be entered when traditional Ademco High
Speed format is used.
*When 4+2 format is used, the 2nd digit of the event code is always "0"

NOTES:

- ¹ After a power reset, or after exiting the Program mode, this code will be sent.
- ² If system is shut down by using a security code while a burglary alarm is sounding, this code will be sent. (Not sent for 24-hour zones).
A Cancel in traditional Ademco High Speed format is the same as an Opening Report for user 15 and should not be used together.

FUNCTION ADDRESS

To disable Restore reports, program all locations in Addresses *69 -*71 as "0".

ZONE TYPES 1-4 RESTORE REPORT ENABLE	*69	1	2	3	4	(See Address *02 for Response types).
		<input type="checkbox"/>	<input type="checkbox"/>	<input type="checkbox"/>	<input type="checkbox"/>	
COMMENTS: Enables Restore reporting for individual zone types. Enter 1 to select restore reporting for the zone type; enter 0 to inhibit restore reports.						
ZONE TYPES 5-8 RESTORE REPORT ENABLE	*70	5	6	7	8	(See Address *02 for Response types).
		<input type="checkbox"/>	<input type="checkbox"/>	<input type="checkbox"/>	<input type="checkbox"/>	
COMMENTS: Enables Restore reporting for individual zone types. Enter 1 to select restore reporting for the zone type; enter 0 to inhibit restore reports.						
ZONE TYPES 9 AND 10 RESTORE REPORT ENABLE	*71	9	10	(See Address *02 for Response types).		
		<input type="checkbox"/>	<input type="checkbox"/>			
COMMENTS: Enables Restore reporting for individual zone types. Enter 1 to select restore reporting for the zone type; enter 0 to inhibit restore reports.						

INTRODUCTION TO FIELD ADDRESSES 72-81

In order to make it easier for an installer to understand expanded zone reporting, an explanation and an illustrative example are given first.

Bearing in mind that a 2-digit reporting code is utilized, let us discuss how zones 1-17, Duress, Zone Expander Supervisory, and the 3 keypad panics (1 & *, 3 & #, and * & #) can be coded. The recurring theme of the following information is that the leading digit represents the type of event being reported and the second digit identifies the zone within that type.

NOTES:

1. Two-digit entries are required because hexadecimal entries are allowed (0-9, B-F) = (00-15) for fields 72-81.
2. Users of the Ademco CAPS Automation System are cautioned not to assign **78** or **8C** for any report, as these codes are reserved.
3. If **Ademco High Speed Format** is selected in either Addresses *46 or *48 and the **4+2 Expanded Zone Format** is selected in Address *53, a very fast 4+2 Format is created that uses DTMF (TouchTone®) signalling instead of pulses. Actually, **9** digits are transmitted but only

the 4+2 portion of the message is ever seen on the central station receiver's display or printer. This High Speed 4+2 format is currently only compatible with Ademco No. 685 Digital Receiver operating with

Revision **4.3** software or higher and has a message transmission time of well under 5 seconds.

EXAMPLE:

An example of code assignments is given below:

Zone	Alarm	Trouble	Bypass	Alarm Restore	Trouble Restore	Bypass Restore
1	11	31	51	71	91	D1
2	12	32	52	72	92	D2
3	13	33	53	73	93	D3
4	14	34	54	74	94	D4
5	15	35	55	75	95	D5
6	16	36	56	76	96	D6
7	17	37	57	77	97	D7
8	19	39	59	79	99	D9
9	21	41	61	81	01	E1
10	22	42	62	82	02	E2
11	23	43	63	83	03	E3
12	24	44	64	84	04	E4
13	25	45	65	85	05	E5
14	26	46	66	86	06	E6
15	27	47	67	87	07	E7
16	28	48	68	88	08	E8
17	10	30	50	70	90	D0
Duress	29	49	69	89	09	E9
Zone Expander	2B	4B	5B	8B	0B	EB
Supervisory						
1 & * Panic	2D	4D	5D	8D	0D	ED
3 & # Panic	2E	4E	5E	8E	0E	EE
* & # Panic	2F	4F	5F	8F	0F	EF

NOTES:

4. English language on the Ademco 685 Digital Receiver should not be used for most of these reports.
5. Note that B and C are not used for leading digits in the above table. It is suggested that these digits be reserved for use in reporting "openings" and "closings" so that the appropriate display and print out can be obtained at the central station receiver and so that an automation system can be given the appropriate information.

FUNCTION	ADDRESS		FUNCTION	ADDRESS	
4+2 EXPANDED FORMAT ZONES 1-8 EVENT DIGIT (1st digit of reporting code)	*72	<input type="checkbox"/> <input type="checkbox"/> ALARM	4+2 EXPANDED FORMAT ZONES 9-16 EVENT DIGIT (1st digit of reporting code)	*73	<input type="checkbox"/> <input type="checkbox"/> ALARM
		<input type="checkbox"/> <input type="checkbox"/> TROUBLE			<input type="checkbox"/> <input type="checkbox"/> TROUBLE
		<input type="checkbox"/> <input type="checkbox"/> BYPASS			<input type="checkbox"/> <input type="checkbox"/> BYPASS
		<input type="checkbox"/> <input type="checkbox"/> ALARM RESTORE			<input type="checkbox"/> <input type="checkbox"/> ALARM RESTORE
		<input type="checkbox"/> <input type="checkbox"/> TROUBLE RESTORE			<input type="checkbox"/> <input type="checkbox"/> TROUBLE RESTORE
		<input type="checkbox"/> <input type="checkbox"/> BYPASS RESTORE			<input type="checkbox"/> <input type="checkbox"/> BYPASS RESTORE
		COMMENTS: The first digit of the 2 digit event code used to report alarm, trouble, bypass and their restores for zones 1-8. Enter all reporting codes as double digits (see Address *65). Disable = 00 (no code reporting)			COMMENTS: The first digit of the 2 digit event code used to report alarm, trouble, bypass and their restores for zones 9-16. Enter all reporting codes as double digits (see Address *65). Disable = 00 (no code reporting)

FUNCTION	ADDRESS	
4+2 EXPANDED FORMAT ZONE 17 EVENT DIGIT (1st digit of reporting code)	*74	<input type="checkbox"/> <input type="checkbox"/> ALARM
		<input type="checkbox"/> <input type="checkbox"/> TROUBLE
		<input type="checkbox"/> <input type="checkbox"/> BYPASS
		<input type="checkbox"/> <input type="checkbox"/> ALARM RESTORE
		<input type="checkbox"/> <input type="checkbox"/> TROUBLE RESTORE
		<input type="checkbox"/> <input type="checkbox"/> BYPASS RESTORE
		COMMENTS: The first digit of the 2 digit event code used to report alarm, trouble, bypass and their restores for zone 17. Enter all reporting codes as double digits (see Address *65). Disable = 00 (no code reporting)
4+2 EXPANDED FORMAT KEYPAD PANICS/ZONE EXPANDER WIRING SUPERVISORY EVENT DIGIT (1st digit of reporting code)	*75	<input type="checkbox"/> <input type="checkbox"/> ALARM
		<input type="checkbox"/> <input type="checkbox"/> TROUBLE
		<input type="checkbox"/> <input type="checkbox"/> BYPASS
		<input type="checkbox"/> <input type="checkbox"/> ALARM RESTORE
		<input type="checkbox"/> <input type="checkbox"/> TROUBLE RESTORE

FUNCTION	ADDRESS		
*75 (CONT'D)		<input type="checkbox"/> <input type="checkbox"/> BYPASS RESTORE	
		COMMENTS: The first digit of the 2 digit event code used to report alarm, trouble, bypass and their restores for various keypad panics (duress, * & #, 1 & *, and 3 & #) and for supervision of the wiring (for short circuits) to the zone expander. Enter all reporting codes as double digits (see Address *65). Disable = 00 (no code reporting).	
	4+2 EXPANDED FORMAT ZONES 1-8 ID DIGIT (2nd digit of reporting code)	*76	Z1 <input type="checkbox"/> <input type="checkbox"/>
			Z2 <input type="checkbox"/> <input type="checkbox"/>
			Z3 <input type="checkbox"/> <input type="checkbox"/>
			Z4 <input type="checkbox"/> <input type="checkbox"/>
		Z5 <input type="checkbox"/> <input type="checkbox"/>	
		Z6 <input type="checkbox"/> <input type="checkbox"/>	
		Z7 <input type="checkbox"/> <input type="checkbox"/>	
		Z8 <input type="checkbox"/> <input type="checkbox"/>	
		COMMENTS: The second digit of the 2 digit event code used to report alarm, trouble, bypass and their restores for zones 1-8. Enter all reporting codes as double digits (see Address *65). Disable = 00 (no code reporting)	

FUNCTION

ADDRESS

**4+2 EXPANDED
FORMAT ZONES
9-16 ID DIGIT
(2nd digit of
reporting code)**

***77**

Z9	<input type="text"/>	<input type="text"/>
Z10	<input type="text"/>	<input type="text"/>
Z11	<input type="text"/>	<input type="text"/>
Z12	<input type="text"/>	<input type="text"/>
Z13	<input type="text"/>	<input type="text"/>
Z14	<input type="text"/>	<input type="text"/>
Z15	<input type="text"/>	<input type="text"/>
Z16	<input type="text"/>	<input type="text"/>

COMMENTS: The second digit of the 2 digit event code used to report alarm, trouble, bypass and their restores for zones 9-16. Enter all reporting codes as double digits (see Address *65). Disable = **00** (no code reporting)

FUNCTION

ADDRESS

**4+2 EXPANDED
FORMAT ZONE
17 ID DIGIT
(2nd digit of
reporting code)**

***78**

Z17	<input type="text"/>	<input type="text"/>
	<input type="text"/>	<input type="text"/>
	<input type="text"/>	<input type="text"/>
	<input type="text"/>	<input type="text"/>
	<input type="text"/>	<input type="text"/>
	<input type="text"/>	<input type="text"/>
	<input type="text"/>	<input type="text"/>
	<input type="text"/>	<input type="text"/>

Zeroes to be entered

COMMENTS: The second digit of the 2 digit event code used to report alarm, trouble, bypass and their restores for zone 17. Enter the reporting code as a double digit (see Address *65) in the first field location (enter **00** in the other seven fields). Disable = **00** (no code reporting)

FUNCTION ADDRESS

**4+2 EXPANDED
FORMAT KEYPAD
PANICS/ZONE
EXPANDER WIRING
SUPERVISORY ID
DIGIT (2nd digit
of reporting code**

***79**

Zeros to be entered

Duress

Short in Wiring to
Zone Expander

1 & * Panic

3 & # Panic

* & # Panic

COMMENTS: The second digit of the 2 digit event code used to report alarm, trouble, bypass and their restores for various keypad panics (duress, * & #, 1 & *, and 3 & #) and for supervision of the wiring (for short circuits) to the zone expander. Enter all reporting codes as double digits (see Address *65). Disable = **00** (no code reporting).

FUNCTION ADDRESS

**4+2 EXPANDED
FORMAT NON-ALARM
CODES**

***80**

CLOSE REPORT (1st digit)

CLOSE REPORT (2nd digit)

OPEN REPORT (1st digit)

OPEN REPORT (2nd digit)

LOW BATT REPORT (1st digit)

LOW BATT REPORT
(2nd digit)

LOW BATT RESTORE
REPORT (1st digit)

LOW BATT RESTORE
REPORT (2nd digit)

TEST REPORT (1st digit)

TEST REPORT (2nd digit)

COMMENTS:

- Enter all reporting codes as double digits (see Address *65).
Disable = **00** (no code reporting)†
both 1st and 2nd digits are so programmed.
- 1st digit of Close Report must be C (hex 12) if English printout of

FUNCTION

ADDRESS

**4+2 EXPANDED
FORMAT NON-ALARM
CODES (CONT'D)**

***81**

- “close” is desired on Ademco No. 685 Receiver or if closing by user is to be processed on an Ademco Automation System
- 1st digit of Open Report must be B (hex 11) if English printout of “open” is desired on Ademco No. 685 Receiver or if opening by user is to be processed on an Ademco Automation System.
 - The 2nd digit of both the Close and Open Reports represents the user ID for the Installation Company Security Code. User No. 2 is automatically assigned an ID one higher than this code (e.g., if 01 is keyed, User 2 reports as 2, User 3 as 3, etc...)

- | | | |
|--------------------------|--------------------------|---|
| <input type="checkbox"/> | <input type="checkbox"/> | POWER UP REPORT (1st digit) |
| <input type="checkbox"/> | <input type="checkbox"/> | POWER UP/DOWNLOAD
ATTEMPT REPORT CODES (2nd digit) |
| <input type="checkbox"/> | <input type="checkbox"/> | AC LOSS REPORT (1st digit) |
| <input type="checkbox"/> | <input type="checkbox"/> | AC LOSS REPORT (2nd digit) |
| <input type="checkbox"/> | <input type="checkbox"/> | AC RESTORE REPORT (1st digit) |
| <input type="checkbox"/> | <input type="checkbox"/> | AC RESTORE REPORT
(2nd digit) |
| <input type="checkbox"/> | <input type="checkbox"/> | Not used -
Zeroes to be Entered |
| <input type="checkbox"/> | <input type="checkbox"/> | Not used -
Zeroes to be Entered |
| <input type="checkbox"/> | <input type="checkbox"/> | CANCEL REPORT (1st digit) |
| <input type="checkbox"/> | <input type="checkbox"/> | CANCEL REPORT (2nd digit) |

COMMENTS:

- Power Up is transmitted after a power reset or after exiting the Program Mode.
- Cancel is transmitted if system is shut down while a **burglary** alarm is sounding.
- Enter all reporting codes as double digits (see Address *65). Disable = **00** (no code reporting) if **both 1st and 2nd digits** are so programmed

FUNCTION ADDRESS

ALARM COUNT *82

COMMENTS: Enter **01 - 15**.
This option limits the number of messages (Alarms or Troubles) sent for a specific channel in an armed period (Swinger Suppression) before additional reports from that channel are inhibited. This selection is system-wide.

TEST REPORT INITIATION TIME *83

COMMENTS: Enter the time in hours from the time that the programming mode is exited that the first test report shall be transmitted. **00** entry signifies immediately upon exiting. **01 - 31** represents the range in hours that can be selected.

ADEMCO HIGH SPEED FORMAT USED ON WATS LINES *84

COMMENTS: Enter **1** if Ademco High Speed Format (either traditional or 4+2 versions) will be transmitted on 800/WATS lines where satellite links may be used. Enter **0** if other formats are selected or if local telco lines are being used.

DO NOT USE *85 **MUST BE ZERO**

COMMENTS: This field is otherwise used for subzone control enable. It is recommended that a 4130NI be used to perform that function instead, for monetary savings.

ZONE EXPANDER TYPE SELECTION *86

COMMENTS: Enter **1** if No. 4208 Eight Zone Expander is being used. Enter **0** if other VECTOR type RPMs are being used to expand the number of zones. **Important:** See the section on an earlier page entitled "Zone Expansion" for proper configuration of the No. 4208.

TESTING THE SYSTEM

After installation is completed, the Security System should be carefully tested.

1. With the System in the disarmed state, check that all zones are intact. If NOT READY is displayed, press READY key to display the faulted zone(s). Restore faulted zone (s) if necessary, so that READY is displayed.

2. Enter the **security code** and press the **TEST** key. The external sounder (if used) should sound for 3 seconds and then turn off (the system is operating on the back-up battery only at this time).

Note 1. The system will not enter the TEST mode, if the battery voltage is too low, if the battery is not connected, or if any communication messages are pending their transmission.

Note 2. As a reminder that the system is in the TEST mode, the Control will sound a single beep at 15-second intervals if no protection zones are violated.

Note 3. In the TEST mode, no reports will be sent to the central station.

Note 4. In TEST mode, the external sounder (if used) will not activate.

3. **Doors and windows:** Open and close each protected door and window in turn. Each action should produce three beeps from the Control. The identification numbers for each protection zone will appear on the Control display.
4. **Motion detectors:** Walk in front of any interior motion detectors (if used). Listen for three beeps when the detector senses movement. While it is activated, its identification number will remain displayed on the Control.
5. **Smoke detectors:** Follow the test procedure provided by the manufacturer of each smoke detector to ensure that all detectors are operational and are functioning properly. **Note:** A Zone 1 2-wire smoke detector display will not clear until the Test mode is exited.

6. To turn off the TEST mode, enter the **security code** and press the **OFF** key.

A message will be sent to the central station during the following tests. Notify the central station that a test will be in progress.

NOTE: A display of "FC" indicates a failure to communicate (no Kiss-off by the receiver at the central station after the maximum number of transmission attempts is tried).

7. Arm the system and fault one or more zones. Silence alarm sounder(s) each time by entering the code and pressing OFF. Check Entry/Exit delay zones.
8. Check the keypad-initiated alarms by simultaneously pressing the Panic keys (***** and **#**, **1** and *****, and/or **3** and **#**). If the system has been programmed for audible emergency, the Control will emit a loud, steady alarm sound, and ALARM and "99" will be displayed for ***** and **#** (if **1** and ***** are pressed, "95" will be displayed; if **3** and **#** are pressed, "96" will be displayed). Silence the alarm by entering the security code and pressing OFF.

If the system has been programmed for silent emergency, there will be no audible alarms or displays, but a report will be sent to the central station.

Notify the central station that all tests are finished, and verify results with them.

TURNING THE SYSTEM OVER TO THE USER

1. Fully explain the operation of the System to the user by going over each of its functions as well as the User's Manual supplied.
2. In particular, explain the operation of each zone (entry/exit, perimeter, interior, fire, etc.). Be sure the user understands how to operate any Emergency feature(s) programmed into the System. **Important:** In the

- spaces provided in the User's Manual, record the Entry and Exit Delay times, and those functions that have been programmed into the available pairs of "Emergency" keys (***** and **#**, **1** and *****, **3** and **#**).
3. Make sure the user understands the importance of testing the system at least weekly, following the procedure provided in the User's Manual.

TO THE INSTALLER

Regular maintenance and inspection (at least annually) by the installer and frequent testing by the user are vital to continuous satisfactory operation of any alarm system. The installer should assume the responsibility of developing and offering a regular maintenance program to the user as well as acquainting the user with the proper operation and limitations of the alarm system and its component parts. Recommendations must be included for a specific program of frequent testing (at least weekly) to insure the system's proper operation at all times.

RECALLING ALARM AND TROUBLE MESSAGES

The system will store up to 10 days worth of alarm and trouble messages for display to service personnel with the following procedure:

Enter: **Security Code** plus **0**

The system's alarm memory retains all events for a period of 10 days, **starting with the first event that occurs**. Upon expiration of the 10-day period, all history is automatically erased and the alarm memory will reset. However, the 10-day cycle will start again **only when the next event occurs**.

Recall by service personnel (using the entry indicated above) will display all events that have occurred from the start of the 10-day cycle to the time of recall (recall always terminates a 10-day cycle). The LCD display

on the Control will indicate the number of the zone in which the event occurred (e.g., 01, 02, etc.), accompanied by the appearance of the word **CHECK** (trouble), **ALARM** and, if applicable, **FIRE**, to describe the type of event that occurred in the displayed zone. If more than one event had occurred, the events will be displayed in zone sequence. Each display will appear for 1-2 seconds, then disappear.

When all information has been displayed and noted, the recall mode is exited by entering:

Security Code plus **OFF**

At this point, all existing memory is erased and the alarm memory is reset. The 10-day cycle will start again only when the next event occurs.

REPLACING FUSES ON 4130XT CIRCUIT BOARD

Two fuses (Battery fuse and Auxiliary Power fuse) are located on the underside of the main circuit board in the 4130XT. To replace either of these fuses, proceed as follows:

1. Remove the 4130XT from its back cover (if present). The 4130XT is released by removing the screw under the nameplate on the front panel (see Diag. 7).
2. If installed, temporarily remove the optional No. 4152LM Loop Module (Diagram 5 shows assembly details). Removal of the Communications Interface board is not necessary.
3. Remove the 24-pin interface connector (field wiring). To facilitate removal, squeeze the tab at top of connector and pull outward with a side-to-side "rocking" motion.
4. Remove the 10-pin Remote Keypad connector (if used).
5. To remove the 4130XT's main circuit board, first remove the single securing screw shown in Diagram 10 (adjacent to the Remote Keypad interface). Then pull each of the two flexible plastic "clasps":

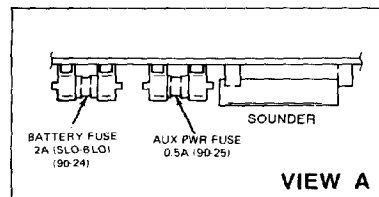

Note: Fuse types used (5 x 20mm European style) are not readily available from electrical supply house and should be inventoried by the installer by pre-ordering from Ademco. Alternatively, these fuses are available at Radio Shack stores.

away from the board to release their hold on one side of the board, and ease the board out, away from the three small plastic clasps on the other side.

6. The two fuses are located on the underside of the main circuit board in the positions shown in Diagram 10. Make sure that the fuses are inserted in their correct locations. **Use exact replacements only.**
7. To re-install the board, insert one edge of the board into the notches in the three smaller plastic clasps first, then push the other side of the board down so that the two larger clasps snap into place over the edge of the board, holding it in place. **Make sure that all keys clear the openings in the front panel and can operate freely.**
8. Insert the screw (previously removed) to secure the board. **Important: It is essential that this screw be replaced.**
9. Re-install the No. 4152LM Loop Module (if removed previously).
10. Reconnect the 10-pin Remote Keypad connector (if used), the 24-pin interface connector, and attach the 4130XT to its back cover (if used).

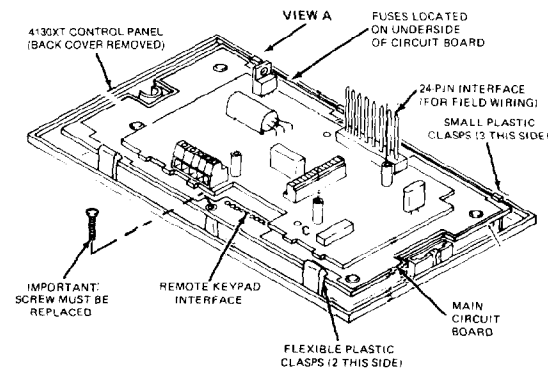

Diagram 10. REMOVING THE MAIN CIRCUIT BOARD FOR FUSE REPLACEMENT

REPLACEMENT PARTS

Description	Part No.		
DC Power Pack - 110V AC Input, 18V DC Output (700 mA max output)	No. 1350	Digital Communication Interface Board	No. 4171XT
Aux Power Fuse (½ Amp)	No. 90-25	10-Pin Connector (for 4131/4147) [with 12" (30 cm) flying leads]	SA4131-10
Battery Fuse (2 Amp, slo-blo)*	No. 90-24	13-Pin Male-to-Male Adapter (4171XT to 4130XT interface)	N3322-13
Trim Ring (for covering overcut walls)	N3724	Battery (12V, 1.2 AH)	No. 484 (YUASA NP1212)
Plastic Standoffs (for mounting 4171XT)	N4062-1	12" (30 cm) Battery Leads, Red & Black	SA4130-4
10-Pin Male-to-Male Adapter-straight (for 4131/4147)	N3707-10	Front Panel Insert (VISTA XT Logo)	N3043-3
24-Pin Connector [with 18" (46 cm) leads]	SA4130-10		

OPTIONAL ACCESSORIES

No. 4137	Remote VISTA Console.	No. 4141-15	Same as above, but with 15' (4.6 m) wiring harness.
No. 4157	Remote VECTOR Console.	No. 4143	Extender Ring for surface mounting 4130XT control with No. 4171XT Communication Interface board.
No. 4131	Remote Keypad.	No. 4147	Remote Keypad, VISTA look alike.
No. 4132	Battery Backbox.	No. 740	High Intensity Alarm Sounder (for outdoor use, mount in No. 742BE Box).
No. 4132-1	Cover for Battery Backbox, required for UL Listed installations.	No. 4148	Relay Module, 2.8 amp rated SPDT contacts.
No. 4133	Rough-in Ring.	No. 4152LM	Zone Expander Interface.
No. 4134-8	8" x 8" x 2" (20 cm x 20 cm x 5 cm) Metal Cabinet	No. 4208	8-Zone Expander.
No. 4134-15	12" x 12" X 3" (30 cm x 30 cm x 7.5 cm) Metal Cabinet	BRK PA400B	Piezoelectric Sounder, 90dB output, mounts in single-gang box.
No. 4136	Cover Plate for Rough-In Ring, Stainless Steel.	No. 90-28	3A SLO-BLO No. 4148 Relay Module fuse.
No. 4141-30	24-Pin Connector with 30' (9 m) wiring harness.		

"FEDERAL COMMUNICATIONS COMMISSION (FCC) STATEMENT"

This equipment has been tested to FCC requirements and has been found acceptable for use. The FCC requires the following statement for your information:

This equipment generates and uses radio frequency energy and if not installed and used properly, that is, in strict accordance with the manufacturer's instructions may cause interference to radio and television reception. It has been type tested and found to comply with the limits for a Class B computing device in accordance with the specifications in Subpart J of Part 15 of FCC Rules, which are designed to provide reasonable protection against such interference in a residential installation. However, there is no guarantee that interference will not occur in a particular installation. If this equipment does cause interference to radio or television reception, which can be determined by turning the equipment off and on, the user is encouraged to try to correct the interference by one or more of the following measures:

- If using an indoor antenna, have a quality outdoor antenna installed.
- Reorient the receiving antenna until interference is reduced or eliminated
- Move the receiver away from the control/communicator.
- Move the antenna leads away from any wire runs to the control/communicator.
- Plug the control/communicator into a different outlet so that it and the receiver are on different branch circuits.

If necessary, the user should consult the dealer or an experienced radio/television technician for additional suggestions.

The user may find the following booklet prepared by the Federal Communications Commission helpful:

"How to Identify and Resolve Radio-TV Interference Problems."

This booklet is available from the U.S. Government Printing Office, Washington, DC 20402. Stock No. 004-000-00345-4.

IN THE EVENT OF TELEPHONE OPERATIONAL PROBLEMS

In the event of telephone operational problems, disconnect the control/communicator by removing the plug from the RJ31X/RJ32X jack. We recommend that the installer demonstrate disconnecting the phones on installation of the system. Do not disconnect the phone connection inside the control/communicator. Doing so will result in the loss of the phone lines. If the regular phone works correctly after the control/communicator has been disconnected from the phone

lines, the control/communicator has a problem and should be returned for repair.

If upon disconnection of the control/communicator, there is still a problem on your line, notify the telephone company that they have a problem and request prompt repair service. The user may not under any circumstances (in or out of warranty) attempt any service or repairs on the system. It must be returned to the factory or an authorized service agency for all repairs.

SPECIFICATIONS

4130XT SECURITY CONTROL:

- 1. Physical:** Width: 8.4 inches (21.3 cm)
 Height: 4.75 inches (12.1 cm)
 Depth: 1.1 inches (2.8 cm)
- 2. Electrical:**
 VOLTAGE INPUT: 18 VDC (from plug-in Power Pack, Ademco No. 1350), 700 mA max.
- RECHARGEABLE BACK-UP BATTERY: 12 VDC, 1.2 AH (Yuasa NP1212 or Ademco No. 484) (alternatively, a 4 AH Ademco No. 486 may be used).
- ALARM SOUNDER: Built-in piezoelectric sounder; 85 db at 10 feet. Sound produced is selectable as "steady" (in compliance with UL 85db output requirement) or "sweeping" (for non-UL usage).
 Optional external 12V Piezo-electric alarm sounder (100 mA max). (Ademco No. 740 or BRK PA400B).
 Optional 12V motor-driven Bell (100ma max.) (AMSECO MSB10-G or ABB-1031).
 Optional dry contact relay (2.8 A max. contact rating @ 28V DC), Ademco No. 4148. Can drive No. 719 or No. 702 siren.
- AUXILIARY POWER OUTPUT: 10.4 - 13.8 VDC (200 mA MAX., 280 mA for non-UL usage)
- STANDBY: 2.5 Hours with 200 mA standby current load. 5 Hours with no external current load.
- FUSES: Battery Fuse: 2 A, Slo-Blo (Ademco No. 90-24)
 Auxiliary Power: 0.5 A (Ademco No. 90-25)

4171XT DIGITAL COMMUNICATION INTERFACE BOARD:

- 1. Physical:** 5-3/4" (14.6 cm) x 3-1/8" (8.25 cm) x 7/8" (2.2 cm) (approx.)
- 2. Functional:** FORMATS SUPPORTED:
Ademco High Speed, 10 characters/sec, DTMF (TouchTone®)
 Data Tones, 1400/2300 Hz ACK, 1400 Hz KISSOFF
Ademco Low Speed, 10 pulses/sec, 1900Hz Data Tone, 1400 Hz ACK/ KISSOFF.
SESCOA, 20 pulses/sec, 1800Hz Data Tone, 2300 Hz ACK/KISSOFF, Variable Interdigit Timing (Use for code reports 0-9)
RADIONICS, 20 pulses/sec, 1800 Hz Data Tone, 2300 Hz ACK/KISSOFF. Fixed Interdigit Timing (Use for code reports 0-9, B-F).
- Line Seize: Double Pole
 Ringer Equivalence: 0.7B
 FCC Registration No.: AC 398U-68192-AL-E

4137 REMOTE CONSOLE

- 1. Physical:** Width: 8.4 inches (21.3 cm)
 Height: 4.75 inches (12.1 cm)
 Depth: 1.1 inches (2.8 cm)
- 2. Electrical:** Voltage Input: 12V DC (and optionally 18VDC)
 Current Drain: 100 mA

3. Interface Wiring:

RED:	12 VDC input (+) —auxiliary power or for battery backup power if No. 1350 is used to separately power the Console(s).
BLUE:	18V DC input (+) — Optional, power from (+) output of separate No. 1350 Power Pack.
GREEN:	Data In
YELLOW:	Data Out
BLACK:	Ground (also connects to (-) output of optional No. 1350 Power Pack above)

4157 REMOTE CONSOLE:

1. Physical:

Width:	6-½" (16.5 cm)
Height:	4" (10.2 cm)
Depth:	1" (2.5 cm)

2. Electrical:

Voltage Input:	12V DC
Current Drain:	120 mA

3. Interface Wiring:

RED:	12V DC input power
GREEN:	Data In
YELLOW:	Data Out
BLACK:	Ground
WHITE:	Auxiliary Sounder (No. 706-12) (optional) (+) connection.

4131/4147 REMOTE KEYPAD:

	4131	4147
1. Physical:	Width: 2-¾" (7.3 cm)	8.4" (21.3 cm)
	Height: 4-¾" (11.7 cm)	4.75" (12.1 cm)
	Depth: 1" (2.5 cm)	1.1" (2.8 cm)

2. Electrical:

Voltage Input	5VDC
Current Drain:	20 mA

Note: Maximum of five 4131/4147 keypads can be supported.

3. Interface Wiring:

1 (BLACK):	Keypad Output
2 (WHITE):	Keypad Output
3 (RED):	Keypad Output
4 (GRAY):	Keypad Output
5 (GREEN):	Keypad Output, RED LED Arming status
6 (BLUE):	Keypad Output, GREEN LED Ready status
7 (YELLOW):	Keypad Output
8 (BROWN):	+5VDC @20 mA Input Power
9 (VIOLET):	Piezoelectric Sounder Input
10 (ORANGE):	Ground

4152LM LOOP MODULE

1. Physical: (Overall)

Width:	3-¼" (8 cm)
Height:	5/8" (1.6 cm)
Depth:	2-5/8" (6.7 cm)

2. Electrical:

Voltage Output:	7-11 volts (w/1 KHz Modulation)
Current Output:	65 mA

3. Interface Wiring:

Terminal 1:	Loop (+)
Terminal 2:	Loop (-)

4. Wiring Run Permitted to No. 4208 Zone Expander (or other VECTOR RPMS):

Wire Gauge	Max. Wire Run
22 (0.64 mm O.D.)	650 ft (200 m)
20 (0.81 mm O.D.)	950 ft (290 m)
18 (1.0 mm O.D.)	1500 ft (460 m)
16 (1.3 mm O.D.)	2400 ft (730 m)

4208 ZONE EXPANDER

1. Physical:	Width:	3-7/8" (9.8 cm)
	Height:	7" (17.8 cm)
	Depth:	1-3/8" (3.5 m)
2. Electrical:	Voltage Input:	8-11 Volts (w/1 KHz Modulation)
	Current Drain:	16 mA

APPENDIX A

CABINET MOUNTING THE 4130XT

In buildings using concrete, cinder block or brick wall construction, the 4130XT Security Control can be installed in a wall-mounted metal cabinet. This cabinet, which measures 8" (20.3 cm) W x 8" (20.3 cm) H x 2" (5 cm) D, is available under part No. 4134-8. The 4130XT Control is mounted in a cut-out in the door of the cabinet, with the function keys, LEDs and display accessible. The back-up battery is installed within the cabinet. Also available for use within the cabinet are connector blocks with which the 4130XT's flying leads can be tied to the interface wiring (from protection zones, etc.). See Diagram B.

Mounting the 4130XT in the Cabinet:

Note that there is a mounting flange on each side of the opening in the cabinet door. The Control is secured to these flanges with the two self-tapping screws supplied. Position the Control (with back cover removed) in the opening and secure as follows, referring to Diagram A.

On the left-hand side, insert the No. 6 x 1" self-tapping screw through the front of the Control into the left flange as shown, and secure. Do not fully tighten yet.

To secure the right-hand side, insert the No. 4 x 1/2" self-tapping screw into the other flange **from the rear**, and screw into the slot in the plastic

at the rear of the Control, as shown. Making sure the Control is straight, tighten this screw fully.

Fully tighten the screw on the other side, then insert the VISTA XT nameplate into the recess to cover the screw, as shown in Diagram A.

Mounting Cabinet on Wall:

Four holes have been provided in the back of the cabinet for mounting purposes - 2 keyhole slots at the top and 2 holes at the bottom. Knock-outs are provided at the sides [7/8" (2.2cm) diameter], plus one at the rear [1-3/4" (4.5 cm) diameter].

1. If the interface wiring is being brought through the wall, make the required opening in the wall for the wiring.
2. Remove the desired knockout in the cabinet to allow entry of the interface wiring.
3. Place the cabinet on the wall in the desired position and mark the locations of the mounting holes.

Note: The cabinet may be mounted with only 2 screws at the keyhole slots, if desired.

4. Drill mounting holes in the wall and insert anchors. Mount the cabinet securely to the wall with four (or 2) screws.

Wiring Connections:

When the Security Control is cabinet-mounted, the flying leads from the 24-pin connector are connected to the interface wires via the terminal blocks provided, as shown in Diagram B. The 12-volt back-up battery is also installed in the cabinet, and connected to the appropriate terminals on TB3, using the two 12-inch (30.5 cm) leads supplied (Red and Black), as shown. The wiring connections are essentially the same as indicated in Diagram 1 (Summary of Connections diagram) except for the terminal blocks shown in Diagram B which are used in place of splices.

Instructions for connection of the optional Remote Keypad and installation and wiring of the digital communication interface board, 4152LM Loop Module and 4208 Zone Expander are provided in a previous section of this manual (see Index).

After all wiring connections are completed, plug the 24-pin interface connector into the rear of the Control.

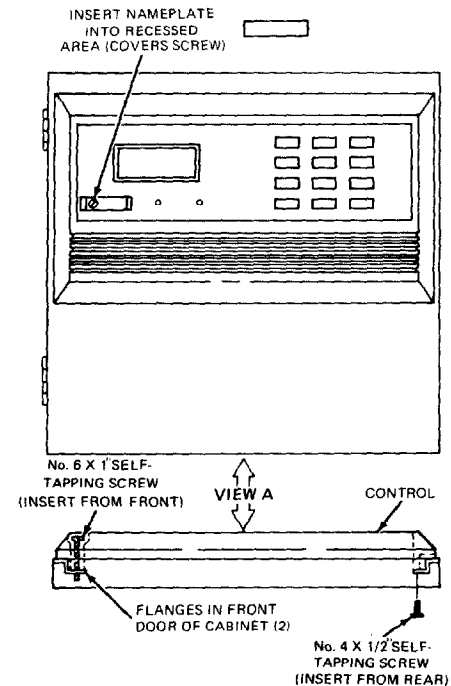

**Diagram A. MOUNTING THE 4130XT
IN CABINET No. 4134-8**

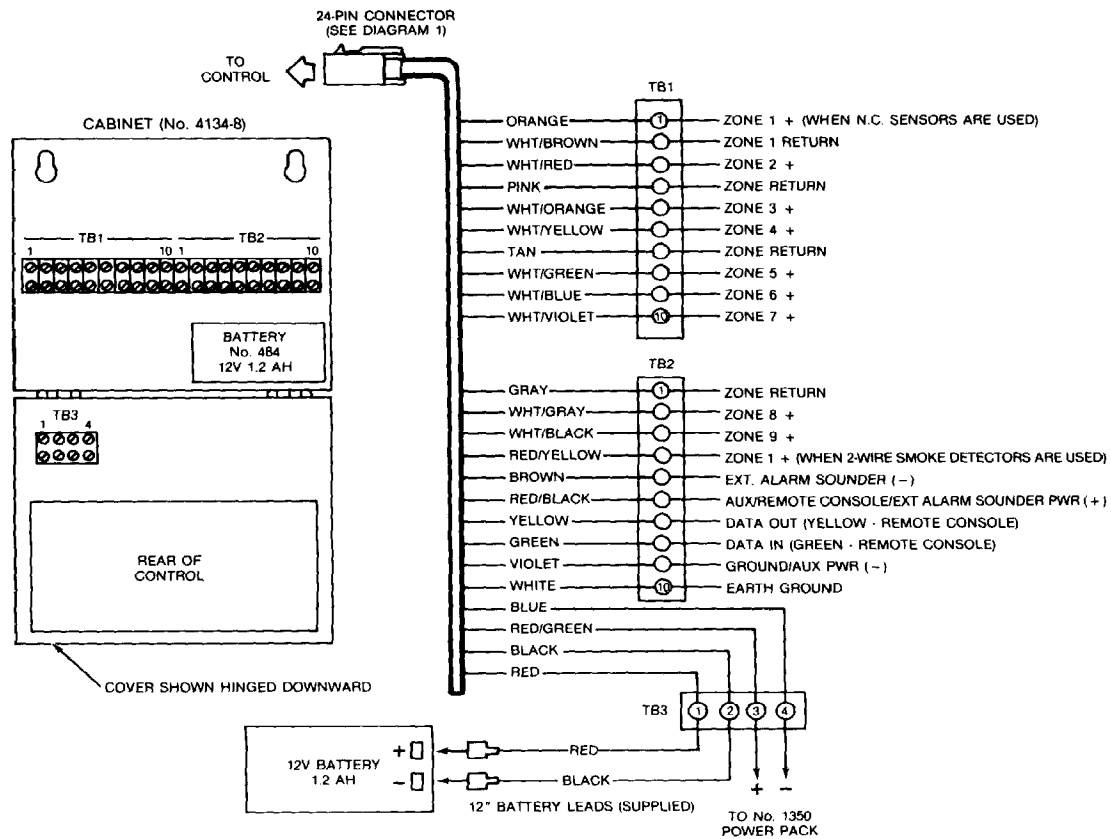

Diagram B. INTERFACE WIRING WHEN THE CONTROL IS CABINET MOUNTED

WARNING
THE LIMITATIONS OF THIS ALARM SYSTEM

While this system is an advanced design security system, it does not offer guaranteed protection against burglary or fire or other emergency. Any alarm system, whether commercial or residential, is subject to compromise or failure to warn for a variety of reasons. For example:

- Intruders may gain access through unprotected openings or have the technical sophistication to bypass an alarm sensor or disconnect an alarm warning device.
- Intrusion detectors (e.g., passive infrared detectors), smoke detectors, and many other sensing devices will not work without power. Battery operated devices will not work without batteries, with dead batteries, or if the batteries are not put in properly. Devices powered solely by AC will not work if their AC power supply is cut off for any reason, however briefly.
- A user may not be able to reach a panic or emergency button quickly enough.
- While smoke detectors have played a key role in reducing residential fire deaths in the United States, they may not activate or provide early warning for a variety of reasons in as many as 35% of all fires, according to data published by the Federal Emergency Management Agency. Some of the reasons smoke detectors used in conjunction with this System may not work are as follows. Smoke detectors may have been improperly installed and positioned. Smoke detectors may not sense fires that start where smoke cannot reach the detectors, such as in chimneys, in walls, or roofs, or on the other side of closed doors. Smoke detectors also may not sense a fire on another level of a residence or building. A second floor detector, for example, may not sense a first floor or basement fire. Moreover, smoke detectors have sensing limitations. No smoke detector can sense every kind of fire every time. In general, detectors may not always warn about fires caused by carelessness and safety hazards like smoking in bed, violent explosions, escaping gas, improper storage of flammable materials, overloaded electrical circuits, children playing with matches, or arson. Depending on the nature of the fire and/or the locations of the smoke detectors, the detector, even if it operates as anticipated, may not provide sufficient warning to allow all occupants to escape in time to prevent injury or death.

- Passive Infrared Motion Detectors can only detect intrusion within the designed ranges as diagrammed in their installation manual. Passive Infrared Detectors do not provide volumetric area protection. They do create multiple beams of protection, and intrusion can only be detected in unobstructed areas covered by those beams. They cannot detect motion or intrusion that takes place behind walls, ceilings, floors, closed doors, glass partitions, glass doors, or windows. Mechanical tampering, masking, painting or spraying of any material on the mirrors, windows or any part of the optical system can reduce their detection ability. Passive Infrared Detectors sense changes in temperature; however, as the ambient temperature of the protected area approaches the temperature range of 90° to 150°F, the detection performance can decrease.
- Alarm warning devices such as sirens, bells or horns may not alert people or wake up sleepers if they are located on the other side of closed or partly open doors. If warning devices sound on a different level of the residence from the bedrooms, then they are less likely to waken or alert people inside the bedrooms. Even persons who are awake may not hear the warning if the alarm is muffled from a stereo, radio, air conditioner or other appliance, or by passing traffic. Finally, alarm warning devices, however loud, may not warn hearing-impaired people or waken deep sleepers.
- Telephone lines needed to transmit alarm signals from a premises to a central monitoring station may be out of service or temporarily out of service. Telephone lines are also subject to compromise by sophisticated intruders.
- Even if the system responds to the emergency as intended, however, occupants may have insufficient time to protect themselves from the emergency situation. In the case of a monitored alarm system, authorities may not respond appropriately.
- This equipment, like other electrical devices, is subject to component failure. Even though this equipment is designed to last as long as 10 years, the electronic components could fail at any time.

The most common cause of an alarm system not functioning when an intrusion or fire occurs is inadequate maintenance. This alarm system should be tested weekly to make sure all sensors are working properly.

Installing an alarm system may make one eligible for lower insurance rates, but an alarm system is not a substitute for insurance. Homeowners, property owners and renters should continue to act prudently in protecting themselves and continue to insure their lives and property.

We continue to develop new and improved protection devices. Users of alarm systems owe it to themselves and their loved ones to learn about these developments.

**ADEMCO
ONE YEAR LIMITED WARRANTY**

Alarm Device Manufacturing Company, a Division of Pittway Corporation ("Seller"), 165 Eileen Way, Syosset, New York 11791, warrants its security equipment (the "product") to be free from defects in materials and workmanship for one year from date of original purchase, under normal use and service. Seller's obligation is limited to repairing or replacing, at its option, free of charge for parts, labor, or transportation, any part proven to be defective in materials or workmanship under normal use and service. Seller shall have no obligation under this warranty or otherwise if the product is altered or improperly repaired or serviced by anyone other than the Seller. In case of defect, contact the security professional who installed and maintains your security system or the Seller for product repair.

This one year Limited Warranty is in lieu of all other express warranties, obligations or liabilities. THERE ARE NO EXPRESS WARRANTIES WHICH EXTEND BEYOND THE FACE HEREOF. ALL IMPLIED WARRANTIES, OBLIGATIONS OR LIABILITIES MADE BY SELLER IN CONNECTION WITH THIS PRODUCT, INCLUDING ANY IMPLIED WARRANTY OF MERCHANTABILITY, OR FITNESS FOR A PARTICULAR PURPOSE OR OTHERWISE, ARE LIMITED IN DURATION TO A PERIOD OF ONE YEAR FROM THE DATE OF ORIGINAL PURCHASE. ANY ACTION FOR BREACH OF ANY WARRANTY, INCLUDING BUT NOT LIMITED TO ANY IMPLIED WARRANTY OF MERCHANTABILITY, MUST BE BROUGHT WITHIN 18 MONTHS FROM DATE OF ORIGINAL PURCHASE. IN NO CASE SHALL SELLER BE LIABLE TO ANYONE FOR ANY CONSEQUENTIAL OR INCIDENTAL DAMAGES FOR BREACH OF THIS OR ANY OTHER WARRANTY, EXPRESS OR IMPLIED, OR UPON ANY OTHER BASIS OF LIABILITY WHATSOEVER, EVEN IF THE LOSS OR DAMAGE IS CAUSED BY THE SELLER'S OWN NEGLIGENCE OR FAULT. Some states do not allow limitations on how long an implied warranty lasts or the exclusion or limitation of incidental or consequential damages, so the above limitation or exclusion may not apply to you.

Seller does not represent that the product may not be compromised or circumvented; that the product will prevent any personal injury or property loss by burglary, robbery, fire or otherwise; or that the product will in all cases provide adequate warning or protection. Buyer understands that a properly installed and maintained alarm may only reduce the risk of a burglary, robbery or fire occurring without providing an alarm, but it is not insurance or a guarantee that such will not occur or that there will be no personal injury or property loss as a result. CONSEQUENTLY, SELLER SHALL HAVE NO LIABILITY FOR ANY PERSONAL INJURY, PROPERTY DAMAGE OR OTHER LOSS BASED ON A CLAIM THE PRODUCT FAILED TO GIVE WARNING. However, if Seller is held liable, whether directly or indirectly, for any loss or damage arising under this Limited Warranty or otherwise, regardless of cause or origin, Seller's maximum liability shall be the complete and exclusive remedy against Seller. This warranty gives you specific legal rights, and you may also have other rights which vary from state to state. No increase or alteration, written or verbal, to this warranty is authorized.

ADEMCO

ALARM DEVICE MANUFACTURING CO.
A DIVISION OF PITTWAY CORPORATION
165 Eileen Way, Syosset, New York 11791

N3122-1 10/88

Copyright © 1988 PITTWAY CORPORATION