

600-1021-95R  
600-1022-95R  
600-1040  
600-1042

# Concord 4 Installation Manual

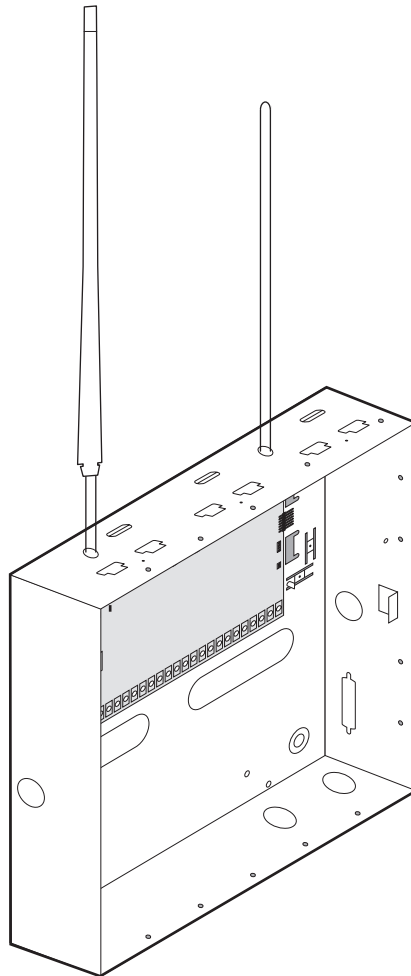

**Copyright** Copyright © 2007 GE Security. All rights reserved.  
This document may not be copied in whole or in part or otherwise reproduced without prior written consent from GE Security except where specifically permitted under US and international copyright law.  
Document number: **466-2182E** (October 2007).

**Disclaimer** The information in this document is subject to change without notice. GE Security, Inc. ("GE Security") assumes no responsibility for inaccuracies or omissions and specifically disclaims any liabilities, losses, or risks, personal or otherwise, incurred as a consequence, directly or indirectly, of the use or application of any of the contents of this document. For the latest documentation, contact your local supplier or visit us online at [www.gesecurity.com](http://www.gesecurity.com).  
This publication may contain examples of screen captures and reports used in daily operations. Examples may include fictitious names of individuals and companies. Any similarity to names and addresses of actual businesses or persons is entirely coincidental.

**Trademarks and patents** GE and the GE monogram are registered trademarks of General Electric Company.  
Concord 4 is a trademark of GE Security.  
Other trade names used in this document may be trademarks or registered trademarks of the manufacturers or vendors of the respective products.  
This product and the use of this product may be covered by one or more of the following patents: 5,805,063; 5,872,512; 5,942,981; 5,686,896; 5,686,885; or 4,855,713.

**Software license agreement** **Important:** This end-user license agreement ("Agreement") is a legal agreement between GE SECURITY and You. Read the following terms and conditions carefully before installing or using this Software. This agreement provides a license from GE SECURITY to use the Software. It also contains warranty information, disclaimers, and liability limitations. Installing and/or using the Software confirms Your agreement to be bound by these terms and conditions. If You do not agree with these terms and conditions, do not install or use the Software or, if already installed, immediately cease all use of the Software and promptly uninstall all components of the Software.

**1. Definitions.** The following definitions apply to this document:

- a. "GE SECURITY", with respect to title to or warranty of the Software, means GE Security Inc., a Delaware corporation.
- b. "Software" mean the executable software or firmware programs and accompanying documentation installed on the GE SECURITY products, plus any upgrades, modified versions, updates, additions, and copies of the software furnished to Customer during the term of the license granted herein.
- c. "Documentation" means all associated media, printed materials, and electronic documentation accompanying the Software.
- d. "Licensed Product" means the Software and Documentation.
- e. "Customer" means the person or organization, or parent or subsidiary thereof, who uses the Software for its intended purposes, and excludes distributors, authorized resellers, value-added resellers and original equipment manufacturers. Customer may be referred to as You or Your, whether an individual or a business entity of any kind.
- f. "Machine" means the computer, workstation, terminal, or other hardware product on which the Software is installed.

**2. License.** All rights to and in the Licensed Product, including, but not limited to, copyrights, patents, trademarks, and trade secrets, belong to GE SECURITY, and GE SECURITY retains title to each copy of the Software. You agree that GE SECURITY at any time, upon reasonable notice, may audit Your use of the Software for compliance with the terms and conditions of this Agreement. Subject to the terms and conditions of this Agreement, GE SECURITY grants You a nonexclusive license to use the Software, but only in the country where acquired, provided that You agree to the following:

You may:

- a. install and use the Software on a single Machine at one time, unless You have purchased additional copies of the Software, in which case You may install the software on the number of Machines for which You have purchased copies of the Software;
- b. use the original copy of the Software provided to You for backup purposes.

You may not:

- a. transfer or distribute the Licensed Product to others, in electronic format or otherwise, and this Agreement shall automatically terminate in the event of such a transfer or distribution;
- b. use the Software over a computer network;
- c. sell, rent, lease, or sublicense the Software;
- d. copy or modify the Licensed Product for any purpose, including for backup purposes.

**3. Term.** This Agreement is effective until terminated. You may terminate this Agreement by uninstalling all components of the Software from all Machines and returning the Software to GE SECURITY. GE SECURITY may terminate this Agreement if You breach any of these terms and conditions. Upon termination of this Agreement for any reason, You agree to uninstall all components of the Software and return the Licensed Product to GE SECURITY. All provisions of this Agreement relating to (i) disclaimer of warranties; (ii) limitations on liability, remedies, and damages; and (iii) GE SECURITY's proprietary rights, shall survive termination of this Agreement.

**4. Object code.** The Software is delivered in object code only. You may not alter, merge, modify, adapt, or translate the Software, nor decompile, disassemble, reverse-engineer, or otherwise reduce the Software to a human-perceivable form, nor create derivative works or programs based on the Software.

**5. Limited warranty.** GE SECURITY warrants that for one (1) year from the date of delivery of the Licensed Product (Software Warranty Period), the functions contained in the Software will be fit for their intended purpose as described in the applicable Documentation from GE SECURITY, and will conform in all material respects to the specifications stated in such Documentation. GE SECURITY does not warrant that the operation of the Software will be uninterrupted or error-free. GE SECURITY does warrant that the media on which the Software is furnished will be free from defects in materials and workmanship under normal use for a period of thirty (30) days from the date of delivery (Media Warranty Period). Except as specifically provided therein, any other software and any hardware furnished with or accompanying the Software is not warranted by GE SECURITY.

Your exclusive remedy under this limited warranty for nonconforming Software shall be repair or replacement of the Software, at the sole discretion of GE SECURITY. To obtain a repair or replacement of nonconforming Software, contact GE SECURITY Customer Service toll-free at 888-GESECURITY or online at [www.gesecurity.com](http://www.gesecurity.com) during the Software Warranty Period.

Except as expressly provided above, the licensed product is provided "as is" without warranty of any kind, either expressed or implied, including, but not limited to, implied warranties of merchantability or fitness for a particular purpose and, except as expressly provided above, You assume the entire risk as to the quality and performance of the licensed product.

**6. Limitation of liability.** GE SECURITY's sole obligation or liability under this agreement is the repair or replacement of nonconforming software and/or defective media according to the limited warranty above. In no event will GE SECURITY be liable for damages, whether consequential, incidental, or indirect, nor for loss of data, loss of profits, or lost savings, arising from use or inability to use the software or documentation (or any hardware furnished with the software), even if GE SECURITY has been advised of the possibility of such damages, nor for any claim by any third party.

**7. General.** Any materials provided to You by GE SECURITY shall not be exported or reexported in violation of any export provisions of the USA or any other applicable jurisdiction. Any attempt to sublicense, assign, or transfer any of the rights, duties, or obligations hereunder shall be void. This Agreement shall be governed by and interpreted under the laws of the State of New York, United States of America, without regard to conflicts of law provisions. You hereby consent to the exclusive jurisdiction of the state and federal courts located in Multnomah County, Oregon, to resolve any disputes arising under or in connection with this Agreement, with venue in Portland, Oregon.

**8. Restricted rights legend.** The Licensed Product is provided with RESTRICTED RIGHTS. In the event the United States Government or an agency thereof is granted a license, the following additional terms apply: Restricted Computer Software, as defined in the Commercial Computer Software–Restricted Rights clause at Federal Acquisition Regulations 52.227-19, and the restrictions as provided in subparagraphs (c)(1) and (c)(2) thereof; and as applicable, the Government's rights to use, modify, reproduce, release, perform, display, or disclose the Software also are restricted as provided by paragraphs (b)(2) and (b)(3) of the Rights in Noncommercial Technical Data and Computer Software–Small Business Innovative Research (SBIR) Program clause at DFARS 252.227-7018.

**9. Acknowledgment.** You acknowledge that You have read and understand this agreement and agree to be bound by its terms. You further agree that this agreement is the complete and exclusive statement of the agreement between You and GE SECURITY, and supersedes any proposal or prior agreement, oral or written, and any other communication relating to the subject matter of this agreement.

<b>Intended use</b>	Use this product only for the purpose it was designed for; refer to the data sheet and user documentation. For the latest product information, contact your local supplier or visit us online at <a href="http://www.gesecurity.com">www.gesecurity.com</a> .
<b>FCC compliance</b>	Changes or modifications not expressly approved by GE Security can void the user's authority to operate the equipment. This equipment has been tested and found to comply with the limits for a Class B digital device, pursuant to part 15 of the FCC Rules. These limits are designed to provide reasonable protection against interference in a residential installation.  This equipment generates, uses, and can radiate radio frequency energy and, if not installed and used in accordance with the instructions, may cause harmful interference to radio communications. However, there is no guarantee that interference will not occur in a particular installation.  If this equipment does cause harmful interference to radio or television reception, which can be determined by turning the equipment off and on, the user is encouraged to try to correct the interference by one or more of the following measures:

Reorient or relocate the receiving antenna.  
Increase the separation between the equipment and receiver.  
Connect the affected equipment and the panel receiver to separate outlets, on different branch circuits.  
Consult the dealer or an experienced radio/TV technician for help.

**ACTA Part 68** This equipment complies with Part 68 of the FCC rules. Located on this equipment is a label that contains, among other information, the FCC registration number and the ringer equivalance number (REN) for this equipment. If requested, this information must be provided to the telephone company.

FCC Part 68 registration number: US:B4ZAL02B55910.

The REN is used to determine the maximum number of devices that may be connected to your telephone line. Excessive RENs on a telephone line may result in devices not ringing in response to an incoming call. In most areas, the sum of all device RENs should not exceed five (5.0). To be certain of the number of devices that may be connected to a line, as determined by the total RENs, contact the local telephone company. For products approved after July 23, 2001, the REN for this product is part of the product identifier that has the format US:AAAEQ##TXXXX. The digits represented by ## are the REN without a decimal point (e.g., 03 is a REN of 0.3). For earlier products, the REN is separately shown on the label.

A plug and jack used to connect this equipment to the premises wiring and telephone network must comply with the applicable FCC Part 68 rules and requirements as adopted by ACTA. A compliant telephone cord and modular plug is provided with this product. It is designed to be connected to a compliant modular jack that is also compliant. See the Installation Instructions for details.

Alarm dialing equipment must be able to seize the telephone line and place a call in an emergency situation. It must be able to do this even if other equipment (telephone, answering system, computer modem, etc.) already has the telephone line in use. To do so, alarm dialing equipment must be connected to a properly installed RJ31X jack that is electrically in series and ahead of all other equipment attached to the same telephone line. If you have any questions concerning these instructions, consult your local telephone company or a qualified installer about installing an RJ31X jack and alarm dialing equipment for you.

If this equipment causes harm to the telephone network, the telephone company may temporarily disconnect your service. If possible, you will be notified in advance. When advance notice is not practical, you will be notified as soon as possible. You will also be advised of your right to file a complaint with the FCC.

The telephone company may make changes in its facilities, equipment, operations, or procedures that could affect the operation of the equipment. You will be given advance notice in order to maintain uninterrupted service.

If you experience trouble with this equipment, please contact the company that installed the equipment for service and/or repair information. The telephone company may ask you to disconnect this equipment from the network until the problem has been corrected or you are sure that the equipment is not malfunctioning. This equipment may not be used on coin service provided by the telephone company. Connection to party lines is subject to state tariffs.

# Contents

<b>Preface</b> .....	<b>vii</b>
Conventions in this document .....	vii
Safety terms and symbols .....	vii
<b>Chapter 1. Introduction</b> .....	<b>1</b>
<b>About this manual</b> .....	<b>2</b>
Special installation requirements .....	2
<b>Planning the installation</b> .....	<b>8</b>
Standard panel .....	8
SuperBus 2000 bus devices .....	9
<b>Chapter 2. Installation</b> .....	<b>11</b>
<b>Installation overview</b> .....	<b>12</b>
Determine the panel location .....	13
Total system power and wire length guidelines .....	13
Mounting the panel .....	16
<b>Identify panel components</b> .....	<b>17</b>
Grounding the panel .....	17
Antenna shrouds .....	18
Installing optional SnapCards .....	18
Zone inputs .....	19
Connecting speakers .....	22
Connecting exterior/interior piezo sirens .....	24
Connecting an Interrogator 200 audio verification module .....	25
Connecting SuperBus 2000 touchpads .....	26
SuperBus 2000 modules .....	26
SuperBus 2000 voice-only module .....	28
SuperBus 2000 cellular backup module .....	33
SuperBus 2000 automation module .....	33
SuperBus 2000 wireless gateway-ready kit .....	34
RJ31X phone jack .....	34
Connecting the phone line to the panel with a DB-8 cord .....	35
Connecting the AC power transformer .....	36
Power .....	37

<b>Chapter 3. Programming .....</b>	<b>39</b>
<b>Overview .....</b>	<b>40</b>
Programming mode .....	40
Touchpad programming options .....	41
Menu navigation .....	42
Exiting programming mode .....	42
<b>Tier 1 system programming menu .....</b>	<b>43</b>
Demo kit mode .....	43
Partition 1 copy .....	44
Clear memory .....	44
<b>Tier 2 programming menus .....</b>	<b>45</b>
Shortcut numbers .....	45
<b>Security menu .....</b>	<b>46</b>
Security - global settings .....	46
Security - partition 1 to 6 settings .....	50
<b>Phones menu .....</b>	<b>53</b>
Phones - central station 1 to 3 settings .....	53
Phones - pager phone 1 to 5 settings .....	56
Phones - downloader phone settings .....	58
<b>Phone options menu .....</b>	<b>59</b>
Phone options - global settings .....	59
Phone options - partition 1 to 6 settings .....	62
<b>Timers menu .....</b>	<b>65</b>
Timers -global settings .....	65
Timers - partition 1 to 6 settings .....	67
<b>Light control menu .....</b>	<b>70</b>
Light control - partition 1 to 6 settings .....	70
<b>Touchpad options menu .....</b>	<b>71</b>
Touchpad options - global settings .....	71
Touchpad options - partition 1 to 6 settings .....	71
<b>Reporting menu .....</b>	<b>73</b>
Reporting - global settings .....	73
Reporting - partition 1 to 6 settings .....	78
<b>Siren options menu .....</b>	<b>83</b>
Siren options - global settings .....	83
Siren options - Partition 1 setting .....	84
<b>Sensors menu .....</b>	<b>85</b>
<b>Audio verification menu .....</b>	<b>89</b>
Audio verification - partition 1 settings .....	89
<b>Accessory modules menu .....</b>	<b>93</b>
Accessory modules - bus device settings .....	93
Accessory modules - SnapCard settings .....	96
<b>Onboard options menu .....</b>	<b>99</b>
Onboard options - inputs settings .....	99
Onboard options - output programming settings .....	100

Onboard options - output text settings .....	101
<b>Macro keys menu .....</b>	<b>102</b>
Macro keys - partition 1 to 6 settings .....	102
<b>Quick programming mode .....</b>	<b>103</b>
<b>User programming mode .....</b>	<b>104</b>
Time and date menu.....	104
User codes menu.....	105
Options menu .....	108
Set up schedules menu .....	109
Attached schedules to events menu .....	110
Energy saver menu .....	112
Attach lights to sensors menu .....	113
System version menu.....	114
<b>Downloader programming .....</b>	<b>115</b>
<b>Testing the system .....</b>	<b>116</b>
Basic system commands .....	116
Zones/sensors.....	118
Phone communication .....	119
Central station/pager communication .....	119
Outputs and sirens .....	121
Light control.....	121
Energy saver module (ESM) .....	122
Fixed display LCD touchpad chime and trouble beep tones.....	122
Touchpad display contrast.....	122
Audio verification module communication .....	123
Cellular backup communication .....	124
<b>Chapter 4. Troubleshooting, maintenance, support .....</b>	<b>125</b>
<b>Troubleshooting.....</b>	<b>126</b>
<b>Contacting technical support.....</b>	<b>133</b>
Online publication library .....	133
<b>Appendix A. System planning sheets .....</b>	<b>135</b>
System planning worksheets .....	136
<b>Appendix B. Settings.....</b>	<b>147</b>
Settings .....	148
<b>Appendix C. Reference tables.....</b>	<b>159</b>
Reference tables .....	160
Cross zoning .....	163
<b>Appendix D. Hardware .....</b>	<b>175</b>
Specifications .....	176
System wiring notes .....	179
Index.....	181





## Preface

This is the *GE Concord 4 Installation Manual*. This document includes an overview of the product and instructions that explain how to install and program your Concord 4 product.

There is also information describing how to contact technical support if you have questions or concerns.

Read these instructions and all ancillary documentation entirely before installing or operating this product. The most current versions of this and related documentation may be found on our website. Refer to [Online publication library](#) on page 133 for instructions on accessing our online publication library.

**Note:** A qualified service person, complying with all applicable codes, should perform all required hardware installation.

## Conventions in this document

The following conventions are used in this document:

<b>Bold</b>	Menu items and buttons.
<i>Italic</i>	Emphasis of an instruction or point; special terms.
	File names, path names, windows, panes, tabs, fields, variables, and other GUI elements.
	Titles of books and various documents.
<i>Blue italic</i>	(Electronic version.) Hyperlinks to cross-references, related topics, and URL addresses.
Monospace	Text that displays on the computer screen.
	Programming or coding sequences.

## Safety terms and symbols

These terms may appear in this manual:



**CAUTION:** *Cautions* identify conditions or practices that may result in damage to the equipment or other property.



**WARNING:** *Warnings* identify conditions or practices that could result in equipment damage or serious personal injury.



# Chapter 1 Introduction

This chapter provides an overview of your Concord 4, including minimum hardware/software requirements and steps you need to perform before you begin installing, configuring, and using your Concord 4.

In this chapter:

<i>About this manual</i> .....	2
<i>Planning the installation</i> .....	8

## About this manual

This manual provides information for planning, installing, programming, and testing this security system. When necessary, this manual refers you to other documentation with compatible peripherals.

Planning sheets are included for you to record hardware layout and software programming settings.

The *Concord 4 User Manual* (466-2183) contains user worksheets that you should fill out during the installation and programming of the system. For multiple-partition systems, we suggest a *User Manual* for each partition.

## Special installation requirements

This security system also functions as a fire warning system, an intrusion alarm system, an emergency notification system, or any combination of the three.

Some installations may require configurations dictated by city/state codes, insurance, or Underwriter's Laboratories (UL). This section describes the various component and configuration listings.

### UL listed installations

This section describes the requirements for UL listed installations.

#### Basic system

- Control panel (600-1021-95R Concord 4 RF, 600-1022-95R Concord Express V4, 600-1040 Concord Commercial V4, or 600-1042 Concord 4 Hybrid).
- Standard class 2 16.5 VAC, 40 VA power transformer 22-145 (600-1023) or 22-145-CN (600-1023-CN), or power line carrier class 2 16.5 VAC, 40 VA power transformer 22-149 (600-1024) or 22-149-CN (600-1024-CN). You must order these transformers separately from GE Security.
- Backup battery 12 V 4.5 or 5.0 Ah (60-681) or 12V 7 AH (60-680).
- SuperBus® 2000 fixed display touchpad (60-820), FTP 1000 (600-1020), 2x16 LCD touchpad (60-746-01), ATP1000 (60-983), ATP2100 (60-985), ATP 2600 (60-984), 2x20 LCD touchpad (60-803), or 2x20 VFD touchpad (60-804).
- Interior speaker siren (60-528), hardwired interior siren (13-949), or speaker siren (13-060).
- Basic system may also include a SuperBus 2000 RF receiver (60-764-95R-01) or a SuperBus transceiver (600-1025-01-95R).

### Household burglary alarm system unit (UL 1023)

Basic system plus the following:

- Hardwired magnetic contact (13-068 or 13-071) or wireless learn mode door/window sensor (60-362).
- Immediate beeps set to on.
- UL 98 options set to on.
- Receiver failure set to on (if wireless devices are used).
- Siren verify set to on.
- Exit delay set to 60 seconds.
- Quick exit set to off.
- Siren timeout set to 4 minutes or more.
- Entry delay set to 45 seconds or less.
- RF Tx timeout set to 24 hours (if system includes a built in receiver or SuperBus 2000 RF receiver or SuperBus 2000 RF transceiver and wireless burglary sensors).
- Extended delay set to off.
- Sleep time set to off.
- Two trip error set to off.
- Alarm verify set to off.
- Disable trouble beeps set to off.

### Household fire warning system (UL 985)

Basic system plus the following:

- Wireless smoke sensor 60-506-319.5 or 60-848-02-95 learned into sensor group 26.
- Immediate beeps set to on.
- UL 98 options set to on.
- Receiver failure set to on (if wireless devices are used).
- Siren verify set to on.
- RF Tx timeout set to 4 hours (if system includes a built-in receiver or SuperBus 2000 RF transceiver and wireless smoke sensors).
- Sleep time set to off.
- Siren timeout set to 4 minutes or more.
- Two-trip error set to off.
- Disable trouble beeps set to off.

### UL 1023 and 985 24-hour backup

For 24-hour backup, the total current draw for all connected devices is limited to 90 mA (during normal standby conditions) using a 4.5 or 5.0 Ah battery, or 190 mA (during normal standby conditions) using a 7.0 Ah battery.

### SIA system requirements

SIA system requirements are the same as those described for a UL listed basic system on [UL listed installations](#) on page 2. If multiple annunciation is required, use additional touchpads. This applies to model

numbers 60-746-01, 60-803, 60-804, 60-820, 60-983, 60-984, 60-985, and 600-1020. UL requirements take priority over SIA requirements.

**SIA setting requirements**

Table 1 describes programming requirements to meet ANSI-SIA CP-01.

Table 1. SIA setting requirements

Shortcut #	Function	Programming page reference	Testing page reference	Default setting	Required setting
0013 - 0063	Exit extension	29	70	On	On
0016 - 0066	Duress code	30	70	Disabled	Disabled
02006	Dialer abort delay	35	70	30 Sec.	15 to 45 sec.
02007	Cancel message	36	70	On	On
02009	Call wait cancel	36	70	Disabled	On if reporting to central station and customer has call waiting service
0310 - 0360	Entry delay	40	70	30 sec.	30 to 240 sec.
0311 - 0361	Exit delay	40	70	60 sec.	45 to 184 sec.
06015	Swinger limit	46	70	1	1
1100	Smoke verify	58	70	Off	On if smoke alarms are programmed into system
N/A	Cross-zoning	91	70	Disabled	Enabled for zones with a high probability of false alarms

Table 2 describes nonprogrammable (hard coded) system operation as required to meet ANSI-SIA CP-01 and is provided only for your reference.

Table 2. ANSI-SIA CP-01 requirements

Function	Operation
SIA false alarm	Enabled
Auto stay arming	Enabled
Disarm during entry delay	Enter code only (or 1 + CODE)
Cancel alarm	Enter code only (or 1 + CODE)
Abort annunciation	Enabled
Entry/exit progress annunciation	Enabled

**Note:** You may use the silent arming feature to suppress arming level and exit beeps for the current arming period. Refer to the *Concord 4 User Manual (466-2183)* for more information on silent arming.

**Commercial burglary alarm system unit (Grade B UL 1610)**

Basic system using control panel 600-1040, SuperBus 2000 RF transceiver module (600-1025-01-95R), plus the following:

- Hardwired magnetic contact (13-068 or 13-071) or wireless learn mode door/window sensor (60-499)
- SAW PIR sensor (60-639-95R), crystal PIR sensor (60-703-95R), or DS924i PIR sensor (60-511-01-95)
- UL Grade A bell/housing, such as Ademco #AB12M or equivalent
- Immediate beeps set to on
- UL 98 options set to on
- Receiver failure set to on (if wireless devices are used)
- RF Tx timeout set to 4 hours
- 24-hour tamper set to on
- System tamper set to on
- Automatic phone test set to on
- Phone test frequency set to 1
- Next phone test set to 1
- Siren verify set to on
- AC failure set to on
- Exit delay set to 120 seconds or less
- Quick exit set to off
- Two-trip error set to off
- Alarm verify set to off
- Disable trouble beeps set to off
- Phone number must be programmed
- High level reports set to on
- Low level reports set to on
- Communication failure set to on
- Extended delay set to off
- Sleep time set to off
- Siren timeout set to 4 minutes or more

**UL 1610 24-hour backup**

Same as UL 1023 and 985.

### **UL 1635 digital alarm communicator system**

For UL 1635 installations, entry delay plus dialer abort delay must not exceed 60 seconds. Same as UL 1023, 985, and 1610 plus:

- AC failure set to on
- Phone number must be programmed
- Low CPU battery set to on
- Next phone test set to 1
- Phone test frequency set to 1
- High level reports set to on
- Low level reports set to on
- Communication failure set to on
- RF Tx timeout set to 4 hours

### **Central station reporting**

The panel was tested with the following central station receivers using SIA and contact ID reporting formats:

- CS-5000 central station receiver
- Sur-Gard central station receiver with models SG-DRL2A and SG-CPM2
- Osborne Hoffman central station receiver

**Note:** The installer must verify the compatibility between this panel and the central station receivers being used.

### **UL Canada listed installations**

This section describes the requirements for CUL (UL Canada) listed installations.

#### **Residential burglary alarm system unit (ULC subject C1023-1974)**

Basic system as described for *UL 1023 listed installations* plus:

- Hardwire magnetic contact (13-068 or 13-071) or wireless learn mode door/window sensor (60-362)
- Siren timeout set to 5 minutes or more

#### **Residential fire warning system control unit (ULC-S545-M89)**

Basic system as described for *UL 985 Listed Installations* plus:

- Hardwired smoke detector: System sensor models 2400 or 2400TH learned into sensor group 26, or ESL models 429AT, 429C, 429CT, 521B, 521BXT, 521NCSXT, 711U, 711UT, 721U, 721UT, TS7-2, or TS7-2T learned into sensor group 26.
- Wireless smoke sensor 60-506-319.5 or 60-848-02-95 learned into sensor group 26.
- Immediate trouble beeps set to on.

**Note:** For 24-hour backup, external power drain is limited to 90 mA (during normal standby condition) using a 4.5 or 5.0 Ah battery, or 190 mA continuous using a 7.0 Ah battery.

- RF Tx timeout set to 4 hours (if system includes SuperBus 2000 RF transceiver and wireless smoke sensors).
- Siren timeout set to 5 minutes or more.



## California State Fire Marshall listed installations

Same as *Household Fire Warning System (UL 985)* plus:

- Smoke verify must be set to off.

## Planning the installation

This section describes system capabilities to help you get familiar with the system. *Appendix A, System planning sheets* provides planning sheets with tables that let you record the hardware and programming configuration of the system. Fill in all necessary information ahead of time to help prepare for system installation.

### Standard panel

Table 3 shows the standard panel capabilities.

Table 3. Panel capabilities

Capabilities	Concord Express v4	Concord4/Concord Commercial v4
Zones	32	96
Partitions	2	6
Bus devices	16	16
User codes	16	230

The following describe the basic panel (out-of-box) hardware capabilities for all panels.

- **Power:** Input for an AC step-down, plug-in style transformer.
- **Auxiliary power output:** Output that supplies 9 to 14 VDC with up to 1 amp for bus devices and hardwired detectors, such as smoke and motion detectors.
- **Bus A and B:** Input and output that provides communication between bus devices and the panel.
- **Siren driver:** Output that can drive an 8-ohm load and provides intrusion and fire alarm sounds for partition 1. Six watts maximum.
- **2 onboard outputs:** Can be used to activate other signaling devices based on system events.
  - Out 1 is a 9 to 14 VDC source output, limited to 1.0 amp max.
  - Out 2 is an open-collector output, rated up to 14 VDC, 300 mA max.
- **Microphone input:** Input used for 2-way audio when used in conjunction with the Interrogator 200 audio verification module.
- **8 supervised hardwired zones:** Inputs for various hardwired detectors. Zone 8 can be set up in programming to accept 2-wire smoke detectors. It sources 9 to 14 VDC, 90mA max.
- **Built-in RF receiver:** Allows use of up to 96 or 32 319.5 MHz. crystal and/or SAW learn mode wireless sensors and touchpads.
- **Phone line connection:** Allows panel to communicate with central monitoring station and/or pagers.

**Note:** The total current sourced from all terminals cannot exceed 1 amp.

## SuperBus 2000 bus devices

You may use the following components with the Concord 4 panel.

You may use the following touchpads for installer/user programming and system operation.

- SuperBus 2000 2x16 LCD touchpad
- SuperBus 2000 2x20 LCD touchpad
- SuperBus 2000 2x20 VFD touchpad
- SuperBus 2000 ATP 1000 touchpad
- SuperBus 2000 ATP 2100 touchpad
- SuperBus 2000 ATP 2600 touchpad
- SuperBus 2000 GTS 50 touchpad

You may use the following touchpads for installer quick programming, system operation and user programming:

- SuperBus 2000 fixed display touchpad
- SuperBus 2000 FTP 1000 touchpad

**SuperBus 2000 RF transceiver.** You may use the transceiver to receive signals from sensors and touchpad that may be on the fringe of panel reception. The transceiver is compatible with all 319.5 MHz crystal and SAW learn mode wireless sensors and touchpads.

**SuperBus 2000 RF receiver.** You may use the receiver to receive signals from sensors and touchpad that may be on the fringe of panel reception. The receiver is compatible with all 319.5 MHz. crystal and SAW learn mode wireless sensors and touchpads.

**Note:** If installing this module, you must turn off the antenna tamper feature.

**Power line carrier transformer.** Using this transformer allows the use of X10 powerhouse lamp modules for light control and light activation during alarms.

**SuperBus 2000 voice only module.** This module provides an output for a speaker that sounds system status and alarm voice messages.

**SuperBus 2000 phone interface/voice module.** This module allows system access and control using touchtone telephones, onsite or offsite. The module includes an output for a speaker that sounds system status and alarm voice messages.

**SnapCards.** The following SnapCards expand the system as described:

- **8Z input SnapCard:** Provides eight additional hardwired zone inputs, of which two are dedicated for using two-wire smoke detectors.
- **4 output SnapCard:** Provides four form C relay outputs that can be set up to activate other signaling devices, based on system events, schedules, or direct control.
- **4Z input/2 output combo SnapCard:** Provides three hardwired zone inputs, one two-wire smoke detector loop, and two outputs that can be set up to activate other signaling devices, based on system events, schedules, or direct control.

**SuperBus 2000 8Z input module (HIM).** Provides eight additional hardwire zone inputs.

**SuperBus 2000 4-relay output module (HOM).** Provides four form C relay outputs that can be set up to activate other signaling devices, based on system events.

**Interrogator 200 audio verification module.** Adding this module allows central station operators to listen in and talk to occupants on the premises to verify the emergency when an alarm report is received.

**SuperBus 2000 cellular backup module.** Provides central station communication (cellular transmission) as a backup to regular phone lines.

**SuperBus 2000 energy saver module (ESM).** Provides a money-saving and convenient way to monitor and control temperatures. The ESM uses low- and high-temperature limits to save energy by overriding the existing HVAC thermostat.

**SuperBus 2000 automation module.** Provides a connection to a compatible home automation device.

**SuperBus 2000 wireless gateway-ready kit.** Allows users to control and monitor the status of their system from the alarm.com internet website.

**SuperBus 2000 2-amp power supply.** Provides an additional 12 VDC, 2 amps for powering system devices and is supervised via the panel data bus.

# Chapter 2 Installation

This chapter provides an overview of your Concord 4, including minimum hardware/software requirements and steps you need to do before you begin installing, configuring, and using your Concord 4.

In this chapter:

- Installation overview* ..... 11
- Identify the components* ..... 17

## Installation overview

This section describes how to install the system control panel. Before starting the installation, plan your system layout and programming using the worksheets provided in *Appendix A, System planning sheets*.

Installing the system consists of the following:

- *Determine the panel location* on page 13
- *Total system power and wire length guidelines* on page 13
- *Mounting the panel* on page 16
- *Identify panel components* on page 17
- *Grounding the panel* on page 17
- *Antenna shrouds* on page 18
- *Installing optional SnapCards* on page 18
- *Zone inputs* on page 19
- *Connecting speakers* on page 22
- *Connecting exterior/interior piezo sirens* on page 24
- *Connecting an Interrogator 200 audio verification module* on page 25
- *Connecting SuperBus 2000 touchpads* on page 26
- *SuperBus 2000 modules* on page 26
- *RJ 31X phone jack* on page 34
- *Connecting the phone line to the panel with a DB-8 cord* on page 35
- *Connecting the AC power transformer* on page 36
- *Power* on page 37

**Note:** Class 2, Class 3, and power-limited fire alarm circuits must be installed using FPL, FPLR, FPLP, or substitute cable permitted by the National Electrical Code ANSI/NFPA 70 or Class 2, Class 3, and power-limited fire alarm circuit conductors must be installed as Class 1 or higher circuits.

**Note:** Class 2, Class 3, and power-limited burglar alarm circuits must be installed using CL2, CL2R, CL2P, or substituting cable permitted by ANSI/NFPA 70. Wire that extends beyond the cable jacket must be separated from all other conductors by a minimum of 0.25 in. or by a nonconductive barrier.

## Determine the panel location

Before permanently mounting the panel, use the following guidelines:

- Centrally locate the panel with relation to detection devices whenever possible, to help reduce wire run lengths and labor.
- Locate the panel where the temperature will not exceed 120°F (49°C) or fall below 32°F (0°C).
- Avoid running wires parallel with electrical wiring or fixtures such as fluorescent lighting, to prevent wire runs from picking up electrical noise.
- Mount the panel at a comfortable working height (about 45 to 55 inches from the floor to the bottom of the panel, as shown in *Figure 1*).

Figure 1. Panel and component locations on a wall

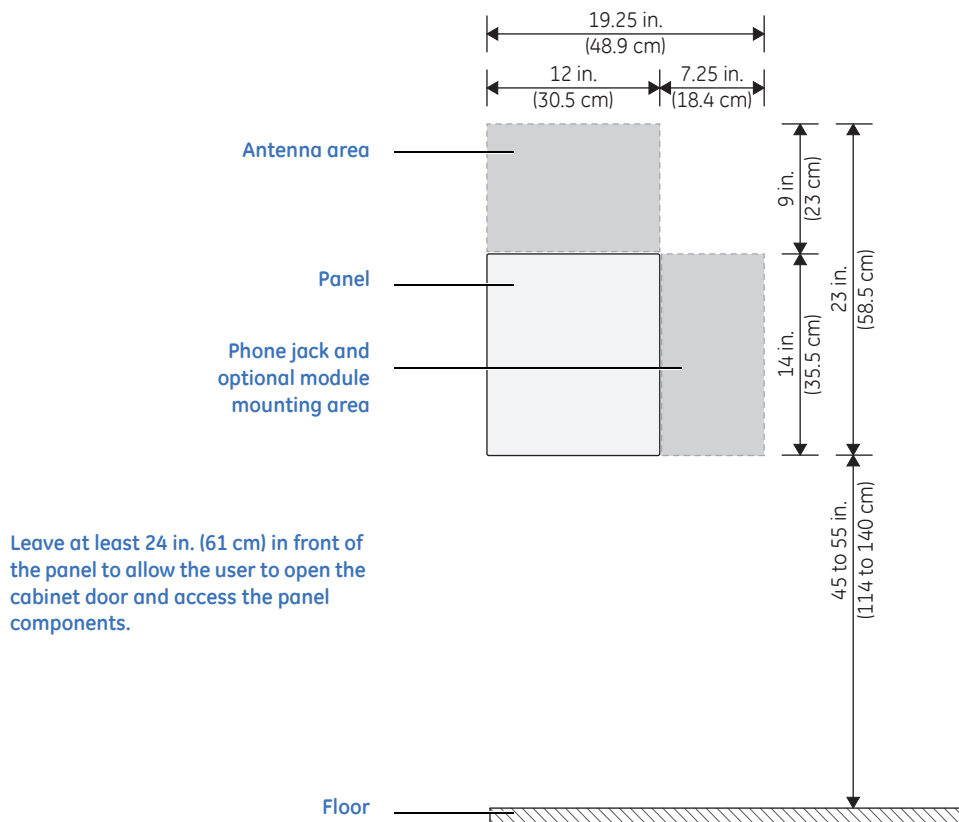

**Note:** Leave space to the left and right of the panel for wiring, phone jack, and mounting optional modules. Allow at least 9 inches above the panel cabinet for antennas. Allow at least 24 inches in front of the panel to open the panel door.

## Total system power and wire length guidelines

The panel can supply up to 1 amp (1,000 mA) in full load alarm condition for system devices connected to panel terminals 4 (+12V), 7 and 8 (speaker terminals), 9 (OUT1), 11 (+12V), 24 (2W SMK ZONE 8), and SnapCard terminals.

For 24-hour backup, the total standby current draw for all devices connected to panel terminals 4 (+12V), 9 (OUT1), 11 (+12V), 24 (if configured for 2-wire smoke loop), and SnapCard terminals is limited to 90 mA

(during normal standby condition) using a 4.5 or 5.0 Ah battery, or 190 mA (during normal standby condition) using a 7.0 Ah battery.

The total system wire length allowed can vary depending on devices powered by the panel, the wire length between devices and the panel, and the combined wire length of all devices.

Table 4 describes the maximum wire length allowed between compatible devices and the panel, and the minimum and maximum current draw of each device.

Table 4. Wire length requirements

Device	Max. wire length to panel	Standby mA draw	Alarm mA draw
SuperBus 2000 2x16 LCD alphanumeric touchpad	22 ga.:300 ft. 18 ga.:750 ft.	15 mA	90 mA
SuperBus 2000 ATP 1000 alphanumeric touchpad	22 ga.:300 ft. 18 ga.:750 ft.	12 mA	110 mA
SuperBus 2000 ATP 2100 alphanumeric touchpad	22 ga.:300 ft. 18 ga.:750 ft.	30 mA	165 mA
SuperBus 2000 ATP 2600 alphanumeric touchpad	22 ga.:300 ft. 18 ga.:750 ft.	30 mA	165 mA
SuperBus 2000 GTS 50	22 ga.:100 ft. 18 ga.:250 ft.	270 mA	300 mA
SuperBus 2000 fixed display touchpad	22 ga.:300 ft. 18 ga.:700 ft.	11 mA	65 mA
SuperBus 2000 FTP 1000 fixed display touchpad	22 ga.:300 ft. 18 ga.:700 ft.	12 mA	75 mA
SuperBus 2000 RF transceiver	22 ga.:1,000 ft. 18 ga.:2,500 ft.	45 mA	55 mA
SuperBus 2000 RF receiver*	22 ga.:1,100 ft. 18 ga.:2,800 ft.	35 mA	35 mA
SuperBus 2000 phone interface/voice module	22 ga.:40 ft. 18 ga.:120 ft.	25 mA	600 mA
SuperBus 2000 voice-only module	22 ga.:40 ft. 18 ga.:120 ft.	20 mA	300 mA (jumper) 600 mA (no jumper)
SuperBus 2000 2 amp power supply		No load	No load
4 input/2 output SnapCard	N/A	20 mA	185 mA*
8Z hardwired zone expander SnapCard	N/A	38 mA	230 mA*
4 output SnapCard	N/A	1 mA	130 mA*
SuperBus 2000 8Z input module	22 ga.:1,800 ft. 18 ga.:4,000 ft.	18 mA	35 mA
SuperBus 2000 4-relay output module	22 ga.:350 ft. 18 ga.:900 ft.	12 mA	180 mA



Table 4. Wire length requirements

Device	Max. wire length to panel	Standby mA draw	Alarm mA draw
SuperBus 2000 energy saver module	22 ga.:1,600 ft. 18 ga.:4,000 ft.	20 mA	20 mA
SuperBus 2000 cellular backup module	Standard power: 22 ga.:15 ft. 18 ga.:40 ft.	90 mA	1600 mA
	High power 22 ga.:10 ft. 18 ga.:30 ft.	90 mA	1900 mA
SuperBus 2000 automation module	22 ga.:1,500 ft. 18 ga.:4,000 ft.	30 mA	35 mA
SuperBus 2000 wireless gateway-ready kit	22 ga.:40 ft. 18 ga.:90 ft.	65 mA	1600 mA
Interrogator 200	22 ga.:3,200 ft. 18 ga.:4,500 ft.	10 mA	10 mA
Interrogator AVM	22 ga.:110 ft. 18 ga.:260 ft.	45 mA	300 mA
2-wire smoke detectors (ESL 429AT, 429C, 429CT, 521B, 521BXT, 521NCSXT)	22 ga.:330 ft. 18 ga.:330 ft.	70 $\mu$ A	60 mA
2-wire smoke detectors (system sensor 2400, 2400TH)	22 ga.:330 ft. 18 ga.:330 ft.	120 $\mu$ A	80 mA
Hardwired interior siren (13-949)	22 ga.:750 ft. 18 ga.:1,500 ft.	0 mA	85 mA
Piezo dynamic exterior siren (13-950)	22 ga.:750 ft. 18 ga.:1,500 ft.	0 mA	150 mA
Speaker siren (60-528 or 13-060)	18 ga.:100 ft.	0 mA	500 mA

\*Maximum current draw for the SnapCards does not include the load which may be applied to their auxiliary DC supply.

**Note:** When installing SuperBus 2000 RF receiver modules, the antenna tamper feature must be set to off (see [Reporting - global settings](#) on page 73).

Table 5 describes the total system wire lengths allowed for all SuperBus 2000 devices when installing systems using unshielded or shielded cable. The maximum wire length for individual devices is shown in Table 6 on page 16.

Table 5. Wire lengths

Wire type	Total system wire
18-gauge, unshielded	4,000 ft.
18-gauge, shielded	3,000 ft.
22-gauge, unshielded	4,000 ft.
22-gauge, shielded	3,000 ft.

After determining panel location, run all necessary wires to that location using the guidelines in *Table 6*.

Table 6. Device wire requirements

Device	Wire requirements
AC power transformer	2-conductor, 18-gauge, 25 feet max
Earth ground	Single conductor, 16-gauge solid, 25 feet max
Telephone (RJ-31X)	4-conductor
Detection devices	2- or 4-conductor, 22-gauge, 1,000 feet max 2- or 4-conductor, 18-gauge, 2,500 feet max (based on 30 ohms max loop resistance including device)
Speakers	2-conductor, 18-gauge, 100 feet max
SuperBus 2000 devices	4-conductor, 22- or 18-gauge
Interrogator 200 AVM power and microphone	4-conductor, 22-gauge, shielded
2-wire smoke detectors	2-conductor, 22-gauge, 330 feet max 2-conductor, 18-gauge, 830 feet max

## Mounting the panel

Mount the panel to the wall or wall studs.



**CAUTION:** Make sure you are free of static electricity whenever you work on the panel with the cover open. To discharge any static, first touch the metal panel chassis, and then stay in contact with the chassis when touching the circuit board. We recommend using a grounding strap

To mount the panel, do the following:

1. Remove the panel door and remove the necessary wiring knockouts. Be careful not to damage the circuit board.
2. Feed all wires through wiring knockouts and place the panel in position against the wall.
3. Level the panel and mark the top and bottom mounting holes (*Figure 1* on page 13).
4. Install anchors where studs are not present.
5. Partially insert screws into the two top mounting hole locations, then hang the panel on the two screws.
6. Recheck for level, insert the two lower screws, and tighten all four mounting screws.

## Identify panel components

Before installing devices and making wiring connections, familiarize yourself with the main panel components. *Figure 2* shows the main component locations.

Figure 2. Motherboard components and mounting holes

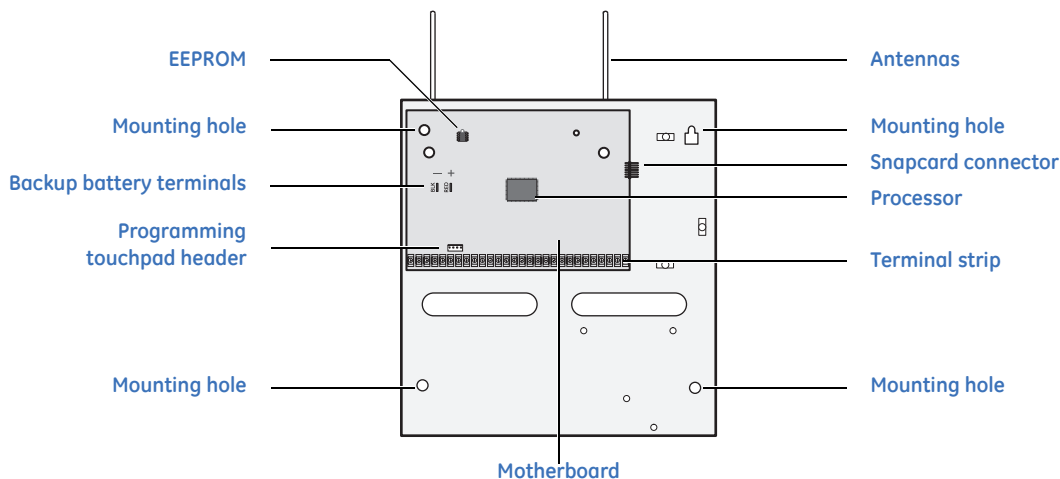

## Grounding the panel

For maximum protection from lightning strikes and transients, connect the enclosure to earth ground as shown in *Figure 3*. Use 16-gauge, solid copper wire from an earth grounded cold water pipe clamp to the enclosure.

Figure 3. Grounding the panel

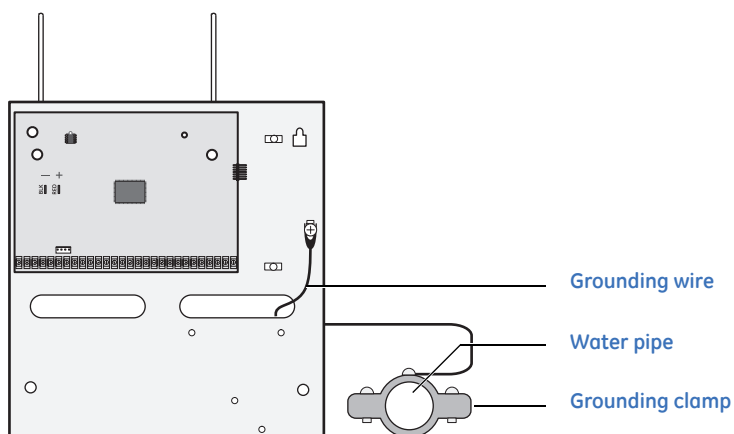

**Note:** For best results, we recommend that you crimp a spade lug on the wire end at the panel and secure the lug to the enclosure.

## Antenna shrouds

Install a plastic antenna shroud (included with panel) over each antenna and snap them into the holes on top of the enclosure (*Figure 4*). Skip this step for hybrid and commercial systems.

Figure 4. Installing antenna shrouds

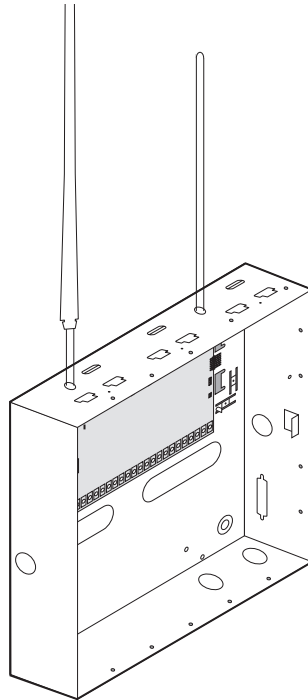

## Installing optional SnapCards

Use the SnapCard header on the right side of the panel (*Figure 5*) to install an optional SnapCard. Install the SnapCard onto the panel SnapCard header and secure it in place with two screws, included with the SnapCard. To connect all necessary input/output wiring, refer to the SnapCard documentation.

Figure 5. Installing a SnapCard

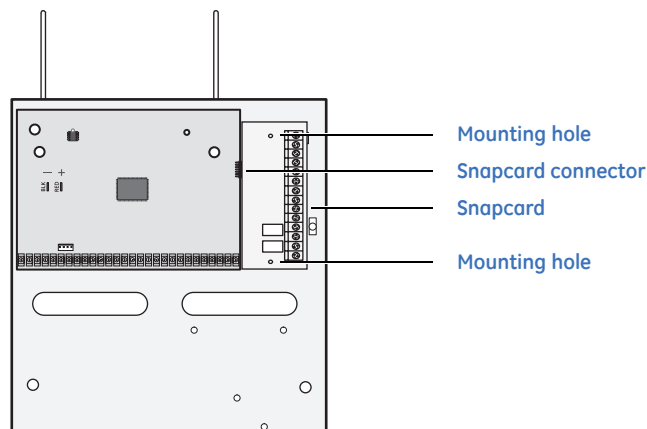

The panel comes with factory programmed onboard hardwired zones. Install 2 kohm, end-of-line (EOL) resistors on all unused factory programmed onboard hardwired zones. If you don't want to install EOL resistors, delete any unused zones from memory.

## Zone inputs

Zone inputs 1 through 8 are supervised using included 2-ohm, end-of-line resistors at the last device on each circuit. All eight zones accept either normally open (NO) or normally closed (NC) detection devices.

### Connecting intrusion detection devices

Figure 6 shows the typical wiring for NC and NO door/window intrusion detection and the typical wiring for a GE PIR. The minimum available panel voltage for hardwired PIR motion detectors is 8.5 VDC (9.5 VDC for UL listed installations).

Figure 6. Connecting N/C and N/O intrusion detection and motion detector circuits to the panel

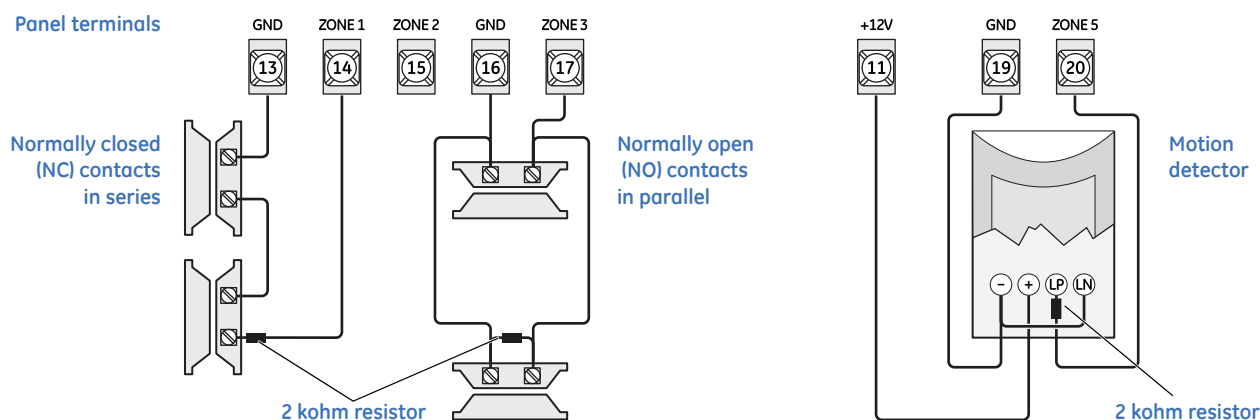

**Note:** When using 2-wire smoke detectors on zone 8, the 2-wire smoke setting (in program mode) must be turned on before entering the learn sensors menu. See Figure 6 for complete details.

### Connecting 2-wire smoke detectors

Zone input 8 can be set up (in program mode) to accept the following 12 VDC, 2-wire smoke detectors:

- *ESL models 429AT, 429C, 429CT, 521B, 521BXT, 521NCSXT* (models 521B and 521BXT require the following dip switch settings: 1-on, 2-off)

**CAUTION:** Use only the 2-wire smoke detector models listed. Alarm signals from other detectors may not process correctly if the panel loses AC power and is operating only from the backup battery.

When set up for 2-wire smoke detectors, zone 8 can handle up to 20 smoke detectors (all of the same model, as listed above) with 120 uA maximum idle current per detector. Maximum total loop current allowed in an alarm condition is 90 mA. Connect one or more, two-wire smoke detectors to the panel as shown in Figure 7 on page 20.

Figure 7. Connecting 2- and 4-wire smoke detectors to the panel

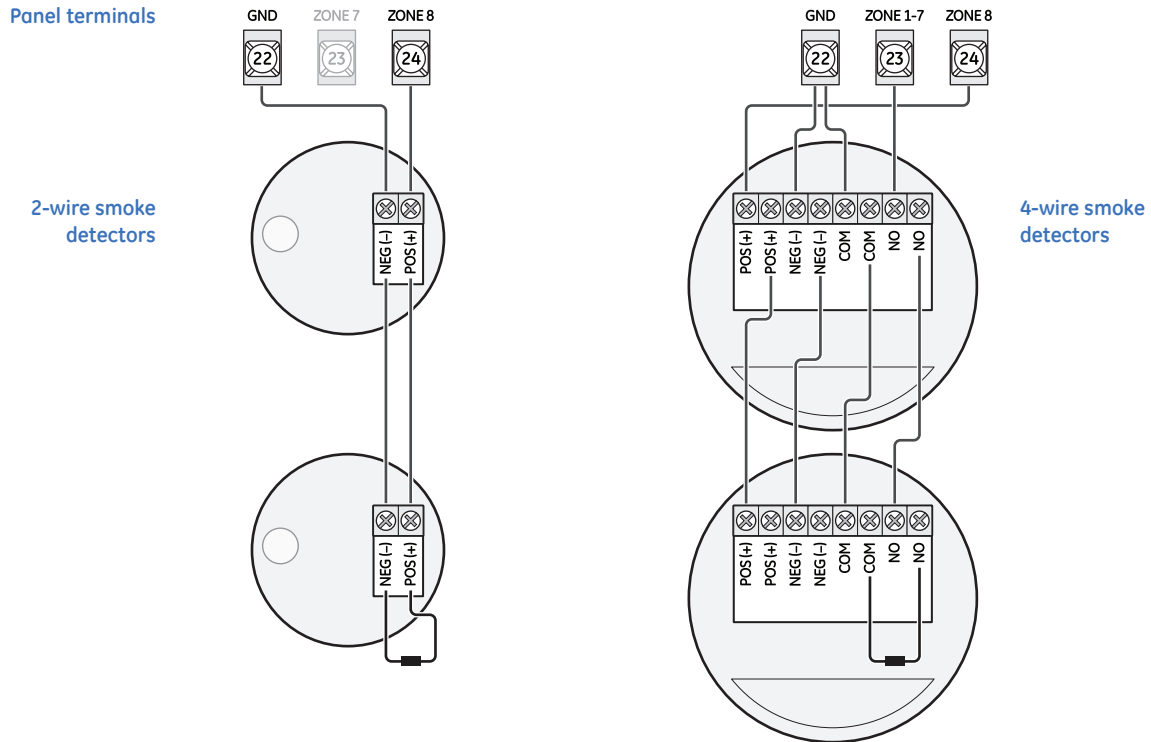

**Note:** The 2-wire smoke setting (in program mode) must be on when using four-wire smoke detectors as shown in Figure 7. See [Onboard options - inputs settings](#) on page 99 for complete details.

If 2-wire smokes with built-in sounders are used (521INCSXT), a polarity reversal relay (model 405-03) may be used to activate the sounders on all smoke detectors during a fire alarm. See [Figure 8](#) on page 21. An output must be used to activate the polarity reversal relay. This output must be configured for fire alarm trigger, and siren tracking response (001-10).

**Note:** Onboard outputs 1 or 2, SnapCard outputs, or output module outputs may be used to activate the polarity reversal relay.

Maximum alarm current is limited to 1.0 A that the panel can source to all external devices. Be sure to include the alarm current for all sounder smoke detectors in the alarm current calculation.

Figure 8. Polarity reversal module

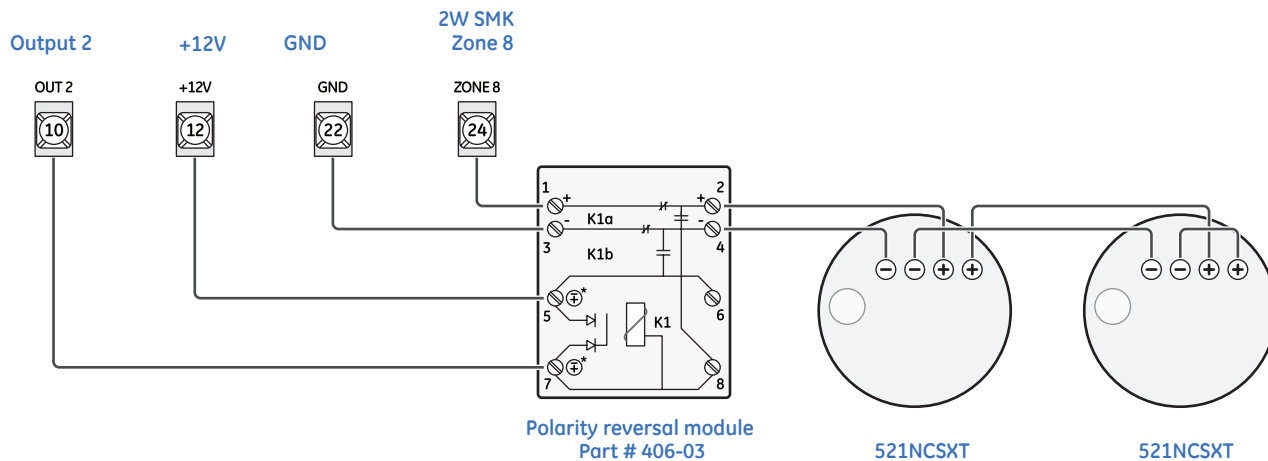

### Connecting 4-wire smoke detectors

Terminal 24 provides power to 4-wire smoke detectors that latch and remain in the alarm state until power turns off, then restores to the detector. The panel provides this power interruption from terminal 24 (2W SMK ZONE 8) only when the 2-wire smoke option is on.

**Note:** The 2-wire smoke feature must be on for smoke detectors to reset after canceling a fire alarm.

Table 7 describes the minimum available panel power. Use only 4-wire smoke detectors that operate at these power limits. Connect up to five GE smoke detectors input as shown in Figure 7.

Table 7. Minimum available panel power

Minimum voltage	Maximum current available
8.3 VDC	Up to 30 mA total (combined alarm) current
8.1 VDC	Up to 40 mA total (combined alarm) current
7.6 VDC	Up to 60 mA total (combined alarm) current
7.1 VDC	Up to 80 mA total (combined alarm) current

## Connecting speakers

The panel provides one siren driver output for intrusion (steady), fire (temporal 3), and auxiliary (on-off-on-off) alarm sounds. This output trips only for partition 1 alarms. Install all sirens/speakers indoors in a concealed location.

**Note:** Do not connect a bell or piezo siren to the speaker output (terminals 7 and 8).

The output can drive a single 8-ohm speaker or multiple speaker circuit of 8 ohms or higher (as shown in the following speaker wiring diagrams). Compatible speakers are shown below.

---

**CAUTION:** To avoid disabling the panel speaker output, do not make speaker connections with the panel power on.

---

### 15-watt speaker (13-060)

For exterior siren applications, connect the speaker to the panel using 18-gauge wire as shown in *Figure 9*.

Figure 9. Connecting exterior speakers to the panel

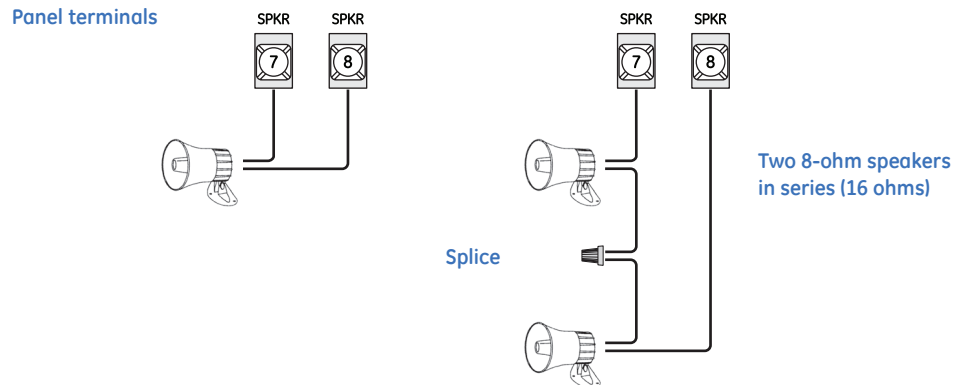

### Hardwired interior speaker (60-528)

Connect interior speakers to the panel using 18-gauge wire as shown in *Figure 10* on page 23.

---

**CAUTION:** Connect only the large speaker to the panel terminals 7 and 8 as shown. The smaller speaker cannot handle output to terminals 7 and 8. To avoid damaging the speaker, do not connect the smaller speaker to terminals 7 and 8.

---



Figure 10. Connecting hardwired interior speakers

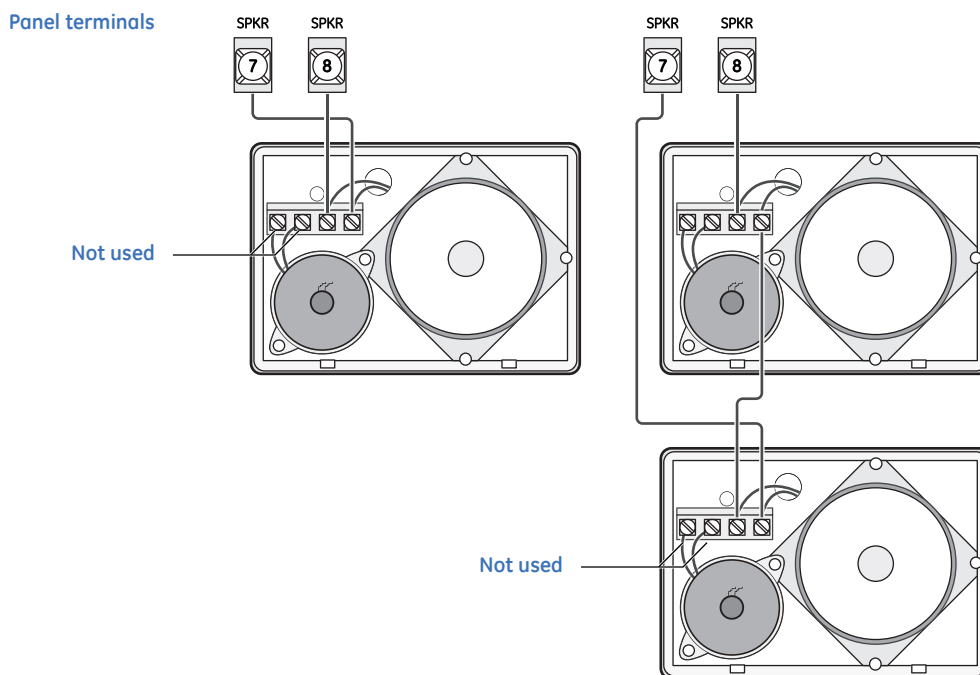

## Connecting exterior/interior piezo sirens

Onboard output 1 (OUT 1—terminal 9) is a 9 to 14 VDC switched, programmable output that can handle a maximum of 1,000 mA current. The default setting (01614) activates the output 30 seconds after a police or fire alarm condition occurs. This allows you to connect a piezo siren without changing the output configuration number in programming. This output is typically for exterior siren applications. (For more information on output configuration numbers, see *Onboard options menu* on page 99.)

**Note:** For 24-hour backup, external power drain is limited to 90 mA (during normal standby condition), using a 4.5 or 5.0 Ah battery, or 190 mA continuous using a 7.0 Ah battery.

### Piezo dynamic exterior siren (13-950)

This siren is not UL listed for use as an outdoor sounding device. Connect the siren to panel as shown in *Figure 11*.

Figure 11. Connecting exterior sirens

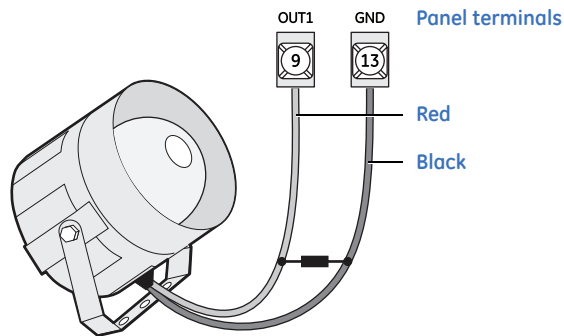

### Output 2

Onboard output 2 (OUT 2—terminal 10) is an open-collector (switched path-to-ground), programmable output that can handle a maximum of 300 mA current sink and up to 14 VDC. The default setting (01710) activates the output for status and alarm tones, allowing for a piezo siren connection without changing the output configuration number. This output is typically used for interior siren applications. (For more information on output configuration numbers, see *Onboard options menu* on page 99.)

### Hardwired interior siren (13-949)

This siren has two inputs; steady (#1) and warble (#2). Use the steady (#1) terminal for Concord 4 panels. The siren also includes a cover tamper switch that can be connected to a hardwired zone input on the panel, SnapCard or SuperBus 2000 hardwired input module. Connect the siren to the panel/zone input terminals as shown in *Figure 12* on page 25.

Figure 12. Connecting an interior siren

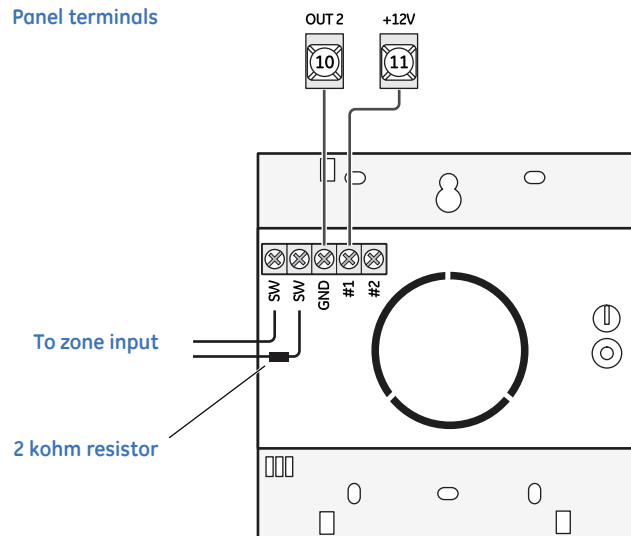

## Connecting an Interrogator 200 audio verification module

Connect the Interrogator 200 audio verification module (AVM) to the panel terminals as shown in *Figure 13*. Partition 1 use only.

Figure 13. Connecting an Interrogator 200 audio verification module

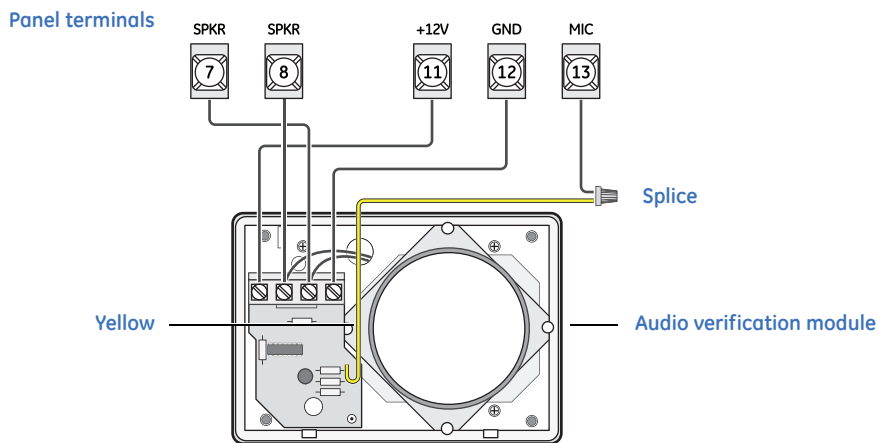

**CAUTION:** If a speaker is already connected to panel terminals 7 and 8, the Interrogator 200 speaker must be hooked up in series with that speaker to provide a 16-ohm load. Hooking up speakers in parallel to panel terminals 7 and 8 creates a 4-ohm load that can cause permanent damage to the panel.

## Connecting SuperBus 2000 touchpads

SuperBus 2000 touchpads may have wires or screw terminals. All use the same wiring scheme for power and bus connections. Connect touchpads as shown in *Figure 14*.

Figure 14. Connecting touchpads to the panel

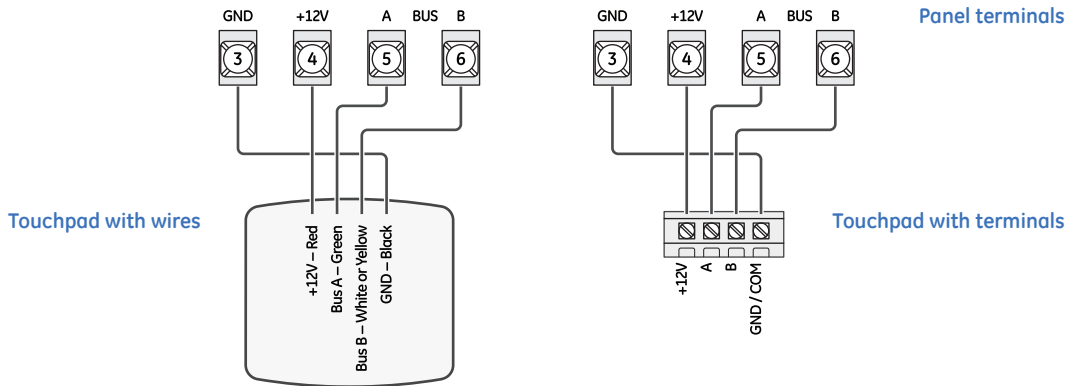

## SuperBus 2000 modules

You may install SuperBus 2000 modules inside the panel cabinet or away from the panel in their included enclosure.

### Mounting modules inside the panel enclosure

Use the following guidelines when mounting modules inside the panel enclosure (*Figure 15*):

- Up to 4 of the SuperBus 2000 modules listed in *Table 1* on page 4 can be mounted inside the cabinet.
- The 2-amp power supply and phone interface/voice module each use two mounting spaces when mounted inside the panel enclosure.
- The panel includes two support standoffs you install to secure module bookplates to the panel.

Even if you don't plan to mount modules inside the cabinet, install the support standoffs for future use and to avoid losing them.

The cabinet has built-in mounting clips on the top and sides that module backplates slide onto for mounting.



Figure 17. Wiring transceivers and receivers to the panel

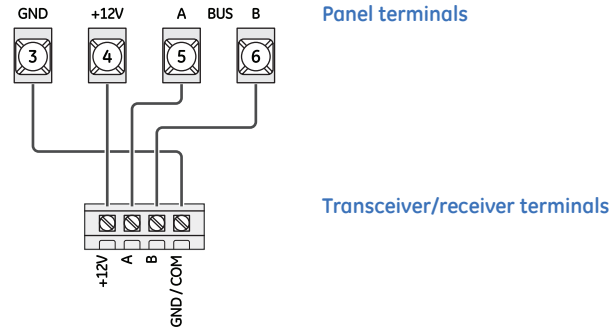

### SuperBus 2000 voice-only module

The module can be mounted inside or outside of the control panel cabinet. Refer to the *SuperBus 2000 Voice Only Module Installation Instructions* included with each module, for complete mounting instructions. For RJ-31X connections, see *Installing an RJ-31X Phone Jack* (13-081).

**Note:** In UL listed installations, the voice-only module is for supplementary use only.

The module requires panel power and bus connections, and speaker connection through panel terminals as shown in *Figure 18*.

Figure 18. Wiring for the voice-only module

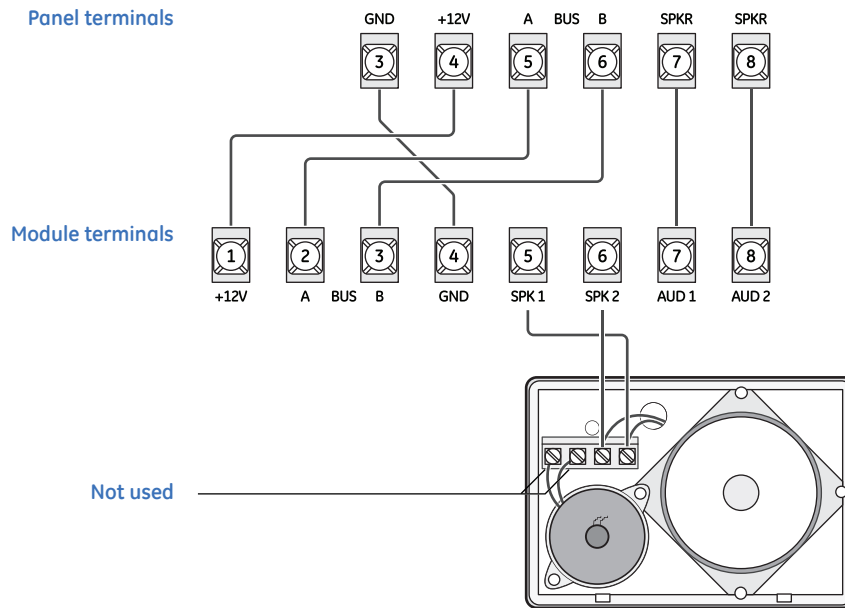

## SuperBus 2000 phone interface/voice module

The phone interface/voice module includes two backplates for mounting the module inside the control panel cabinet. You may also mount the module outside of the cabinet using an optional plastic housing (part no. 60-800). Refer to the documentation that comes with each module, for complete mounting instructions.

**Note:** In UL listed installations, the phone interface/voice module is for supplementary use only.

The module requires panel power and bus connections, phone line connection through panel terminals and DB-8 cord (from an RJ-31X jack), and speaker connection through panel terminals. Connect the module to the panel power and bus terminals as shown in *Figure 19*.

For partition 1, connect the phone line to the module through the panel terminals and DB-8 cord (from an RJ-31X jack) as shown in *Figure 19* on page 29. For partitions 2 to 6 phone connections, see the documentation that comes with each module.

Figure 19. Wiring the phone interface/voice module

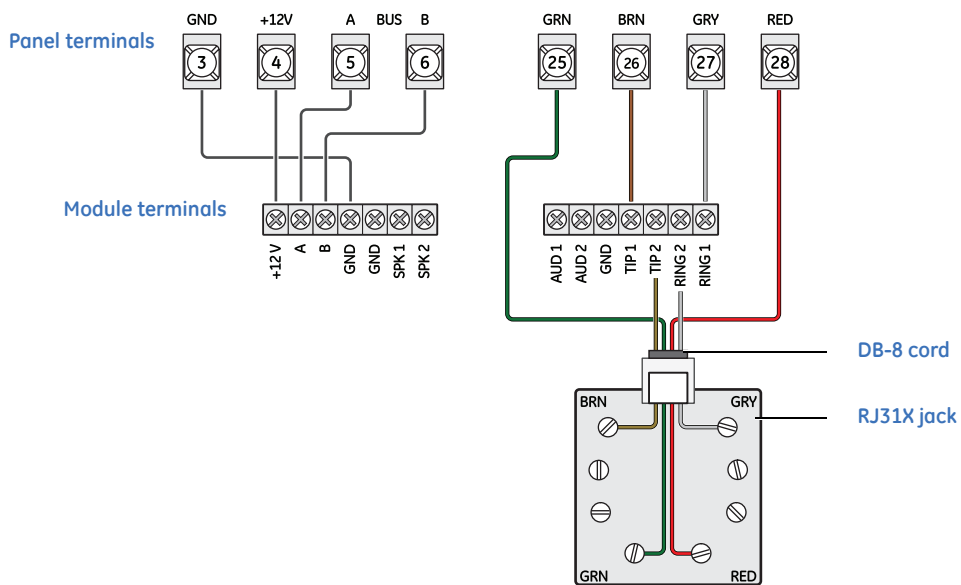

**Note:** To prevent status voice messages from being broadcast outside, do not connect exterior speakers to phone interface/voice module terminals 6 and 7.

### Wiring for status voice messages only

Connect an interior speaker to the phone interface/voice module terminals as shown in *Figure 20*. When connected as shown, the speaker only produces status voice messages. In an alarm, the speaker announces voice status messages.

### Wiring for status and alarm messages

Make all of the connections shown in *Figure 20* only if the phone interface/voice module is being installed in partition 1 and alarm sounds are desired. In an alarm, the speaker alternates between alarm siren tones and voice status messages.

Figure 20. Wiring the phone interface or voice module for status and alarm (or status only) messages

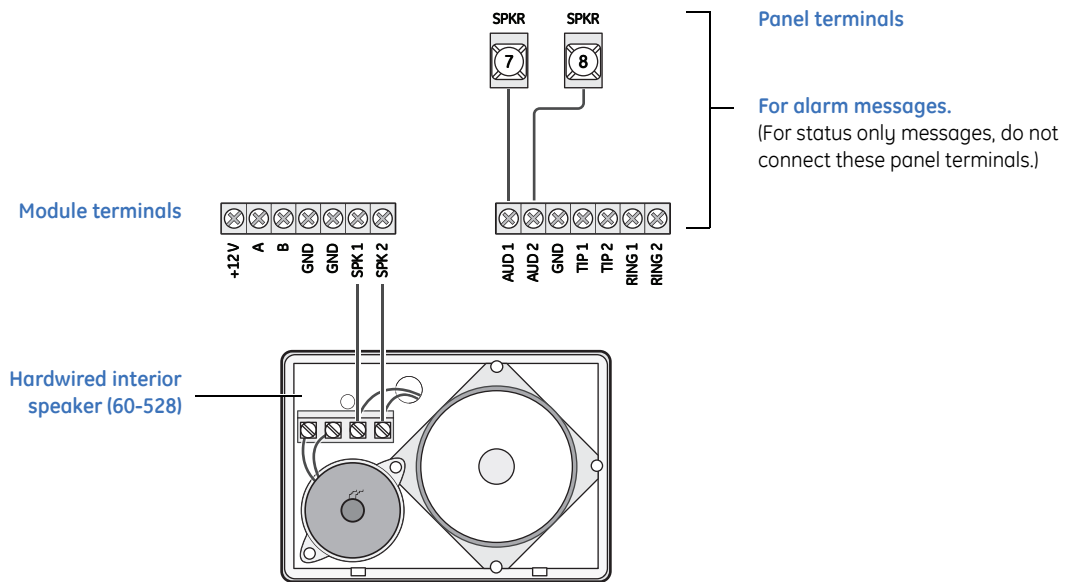



## SuperBus 2000 energy saver module

Connect the energy saver module to the panel and premises thermostat as shown in *Figure 21*.

Figure 21. Wiring the thermostat and energy saver module to the panel

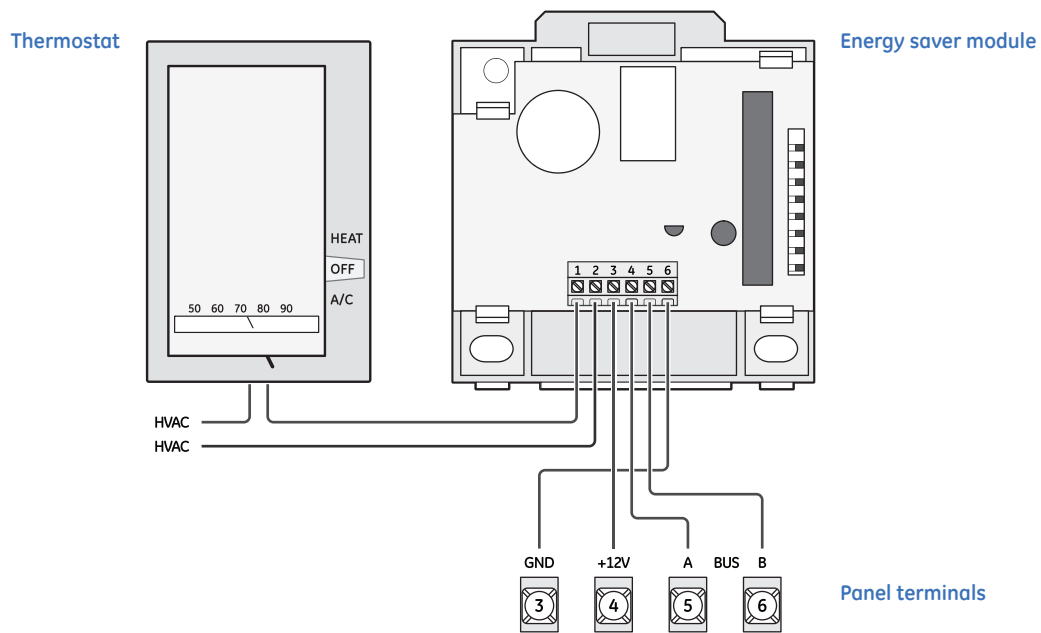

### SuperBus 2000 8Z input and SuperBus 2000 4-relay output module

Connect the modules to the panel as shown in *Figure 22*. Connect all necessary input and output wiring using the documentation that accompanies the module.

Figure 22. Wiring input and output modules to the panel

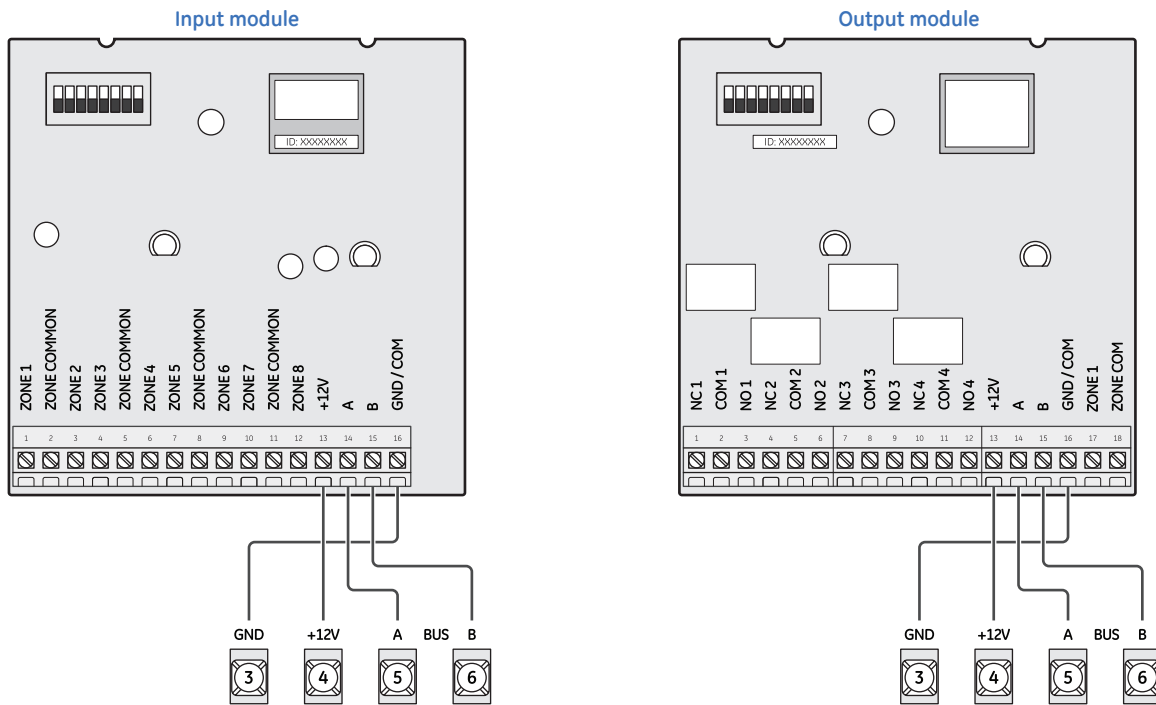

## SuperBus 2000 cellular backup module

Connect the SuperBus 2000 cellular backup module to the SuperBus 2000 2-amp power supply and panel as shown in *Figure 23*.

Figure 23. Wiring the cellular backup module to the panel

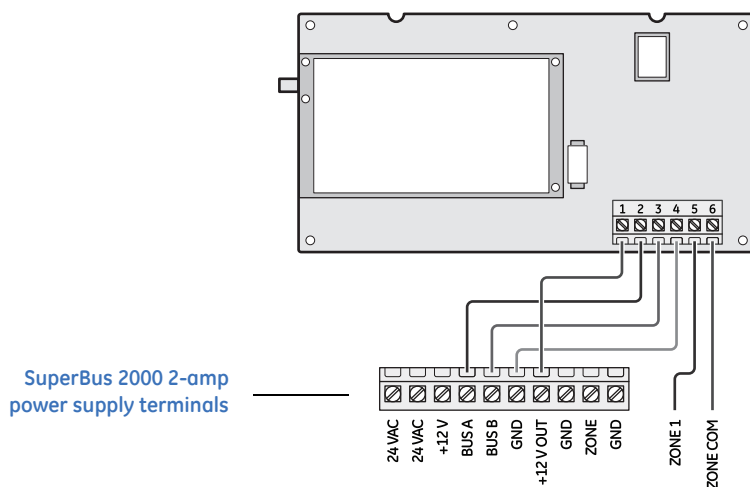

**CAUTION:** Since the SuperBus 2000 cellular backup module draws more than 1 amp, it must be powered by the SuperBus 2000 2-amp power supply and not the panel.

## SuperBus 2000 automation module

Connect the SuperBus 2000 automation module to the panel as shown in *Figure 24*.

Figure 24. Connecting an automation device to the panel

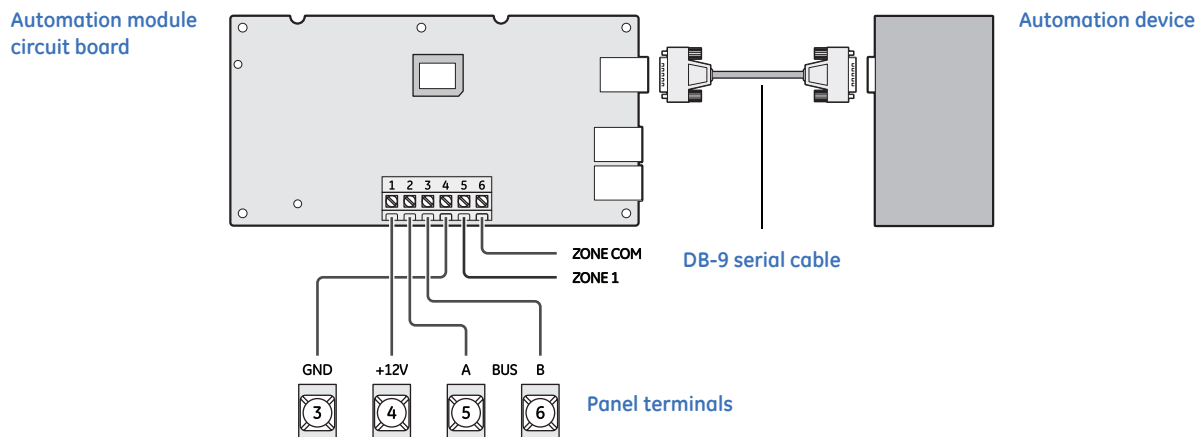

## SuperBus 2000 wireless gateway-ready kit

Connect the SuperBus 2000 wireless gateway module to the SuperBus 2000 terminals as shown in *Figure 25*.

Figure 25. Connecting a wireless gateway module to the panel

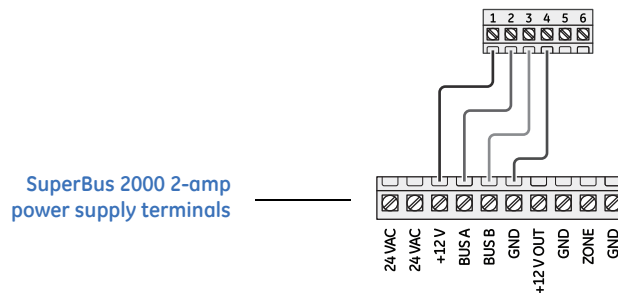

The panel cannot be used on a digital or PBX phone line. These systems are designed for digital type devices only, operating anywhere from 5 VDC and up. The panel uses an analog modem and does not have a digital converter, adapter, or interface to operate through such systems.

## RJ31X phone jack

Use the following guidelines when installing an RJ31X phone jack for system control by phone and central station monitoring:

- Locate the RJ31X jack (CA-38A in Canada) no further than five feet from the panel.
- The panel must be connected to a standard analog (loop-start) phone line, that provides 48 VDC (on-hook or idle).
- For full line seizure, install an RJ31X phone jack on the premises phone line so the panel is ahead of all phones and other devices on the line. This allows the panel to take control of the phone line when an alarm occurs, even if the phone is in use or off-hook.

**Note:** Connecting the panel to an analog line off the phone switch places the panel ahead of the phone system, preventing panel access from phones on the premises. However, the panel can still be accessed from offsite phones.

- If an analog line is not available, contact a telecommunication specialist and request an analog line off the phone switch (PBX mainframe) or a 1FB (standard business line).

To connect a phone line to the panel using an RJ31X/CA-38A jack, see *Figure 26* on page 35, and do the following:

1. Run a four-conductor cable from the TELCO protector block to the jack location.
2. Connect one end of the cable to the jack.
3. At the TELCO protector block, remove the premises phone lines from the block and splice them to the black and white (or yellow) wires of the 4-conductor cable.
4. Connect the green and red wires from the 4-conductor cable to the TIP (+) and RING (-) posts on the block.

5. Check the phones on the premises for a dial tone and the ability to dial out and make phone calls. If phones do not work correctly, check all wiring and correct where necessary. See [Troubleshooting](#) on page 126.

## Connecting the phone line to the panel with a DB-8 cord

After installing the RJ31X jack, you are ready to connect the phone line to the panel. A DB-8 cord (not included) uses a plug at one end for connecting to the RJ31X module and flying leads on the other end for panel terminal connections.

To connect the DB-8 cord to the panel terminals and RJ31X jack, (see *Figure 26* on page 35), and do the following:

1. Connect the green, brown, gray, and red flying leads from the DB-8 cord to panel terminals 25, 26, 27, and 28.
2. Insert the DB-8 cord's plug into the RJ31X.
3. Check the phones on the premises for a dial tone and the ability to dial out and make phone calls. If phones do not work correctly, check all wiring and correct where necessary. See [Troubleshooting](#) on page 126.

Figure 26. Wiring an RJ31X jack and DB-8 cord to the panel

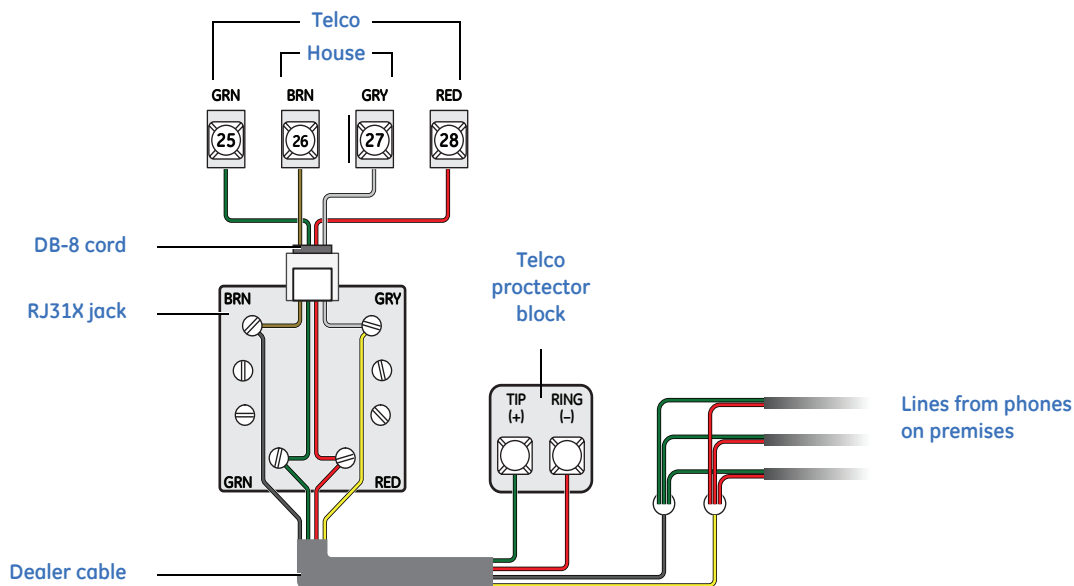

## Connecting the AC power transformer

The panel must be powered by a plug-in stepdown transformer that supplies 16.5 VAC, 40 VA (600-1023 or 600-1023-CN).

---

 **CAUTION:** Do not plug in the power transformer or connect the backup battery at this time. The panel must be powered up using the sequence of steps described in *Power* on page 37.

---

For systems that include X10 lamp modules, the panel must be powered with the line carrier power transformer that supplies 16.5 VAC, 40 VA (600-1024 or 600-1024-CN). Connect the power transformer to the panel as shown in *Figure 27*.

Figure 27. Connecting panel power transformer and backup battery

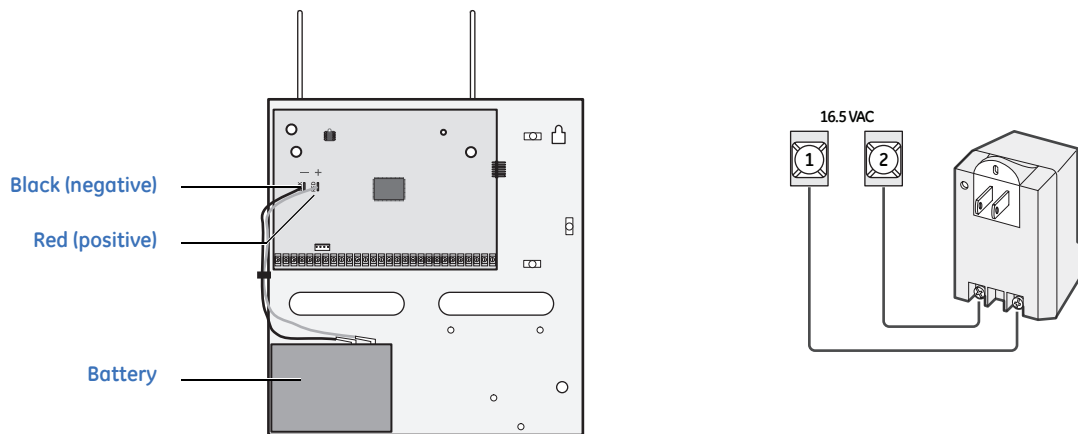

## Power

After connecting and wiring all devices to the panel, you are ready to apply AC and backup battery power to the panel.

**Note:** The backup battery leads must be routed along the side of the enclosure and secured with a cable tie.

To power up the panel see *Figure 27* on page 36, and do the following:

1. Connect the red and black battery leads (included with panel) to the lugs on the panel.
2. Connect the other ends of the battery leads to the battery terminals.
3. Plug the transformer into an outlet that is not controlled by a switch.
4. Alphanumeric touchpads display `*****`, then `SCANNING BUS DEVICES`, and finally a date and time display.

**Note:** If alphanumeric touchpads don't display anything, immediately unplug the transformer and disconnect the backup battery. See [Troubleshooting](#) on page 126.

5. To permanently mount the transformer, unplug it and remove the existing screw securing the AC outlet cover.



**WARNING:** Use extreme caution when securing the transformer to a metal outlet cover. You could receive a serious shock if a metal outlet cover drops down onto the prongs of the plug while you are securing the transformer and cover to the outlet box.

---

6. Hold the outlet cover in place and plug the transformer into the lower receptacle.
7. Use the screw supplied with the transformer to secure the transformer to the outlet cover.





# Chapter 3 Programming

This chapter provides instructions on how to program the Concord 4 and includes descriptions of the programming settings.

In this chapter:

<i>Overview</i> .....	40
<i>Tier 1 system programming menu</i> .....	43
<i>Tier 2 programming menus</i> .....	45
<i>Security menu</i> .....	46
<i>Phones menu</i> .....	53
<i>Phone options menu</i> .....	59
<i>Timers menu</i> .....	65
<i>Light control menu</i> .....	70
<i>Touchpad options menu</i> .....	71
<i>Reporting menu</i> .....	73
<i>Siren options menu</i> .....	83
<i>Sensors menu</i> .....	85
<i>Audio verification menu</i> .....	89
<i>Accessory modules menu</i> .....	93
<i>Onboard options menu</i> .....	99
<i>Macro keys menu</i> .....	102
<i>Quick programming mode</i> .....	103
<i>User programming mode</i> .....	104
<i>Downloader programming</i> .....	116
<i>Testing the system</i> .....	117

## Overview

For onsite system programming, you must have an alphanumeric touchpad.

### Programming mode

You must use an installer/dealer code (default = 4321) to enter program mode. You may place the system into programming mode only when you disarm all partitions.

**Note:** If the system is powered up after the programming touchpad is connected or if a bus command scan is executed, the programming touchpad will be “learned” into the system and must later be manually deleted.

To enter program mode, do the following:

1. Make sure you disarm the system in all partitions.
2. Press **8 + 4321 + 0 + 0**. The display shows `SYSTEM PROGRAMMING`.

To enter programming mode using a programming touchpad, do the following:

1. Connect the red, black, green, and white wires from the programming touchpad cable (60-791) to the power and bus wires/terminals on an alphanumeric touchpad, matching the +12V (red), Bus A (green), Bus B (white), and GND (black) on each.
2. Make sure the system is powered up and disarmed.
3. Connect the plug on the cable onto the panel programming touchpad header (see *Figure 28*).
4. Press **8 + 4321 + 0 + 2**. The touchpad sounds one short beep. Press **\*** and verify that the display shows `SERVICE TOUCHPAD ACTIVE`.
5. Press **8 + 4321 + 0 + 0** and the display shows `SYSTEM PROGRAMMING`.
6. After programming is complete, disconnect the touchpad from the panel header.

Figure 28. Programming touchpad

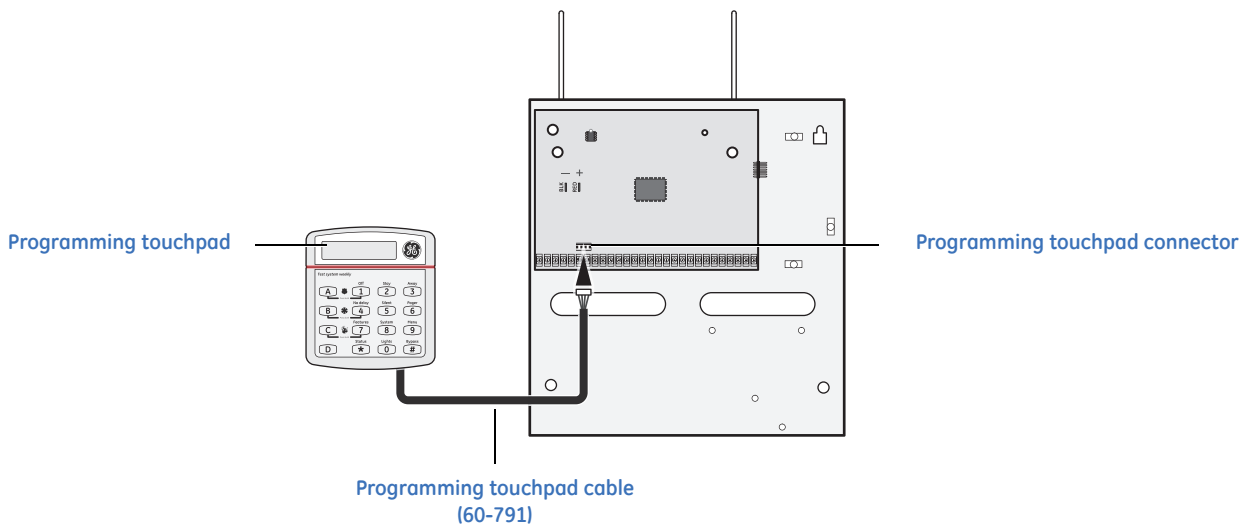

## Touchpad programming options

In program mode, touchpad buttons let you navigate to all installer programming menus for configuring the system. *Table 8* describes the touchpad button functions in program mode.

Table 8. Touchpad programming functions

Button	Programming function
#	Select menu item or data entry.
*	Deselect menu item or data entry (if pressed before #).
A (▲) B (▼)	Scroll through available options at the current menu tier. Also scroll through sensor text options during sensor text programming.
C	Enter pauses when programming phone numbers.
D	Delete certain programmed settings.
0 to 9	Enter numeric values wherever needed.
1 and 2	Select off (1) or on (2) wherever needed.
1 to 6	Press and hold to enter alphabetical characters A through F for account numbers
7 and 9	Press and hold to enter * (7) or # (9) for phone numbers.

## Menu navigation

There are two basic tiers of programming menus (*Table 9*).

Table 9. Tier 1 and 2 menus

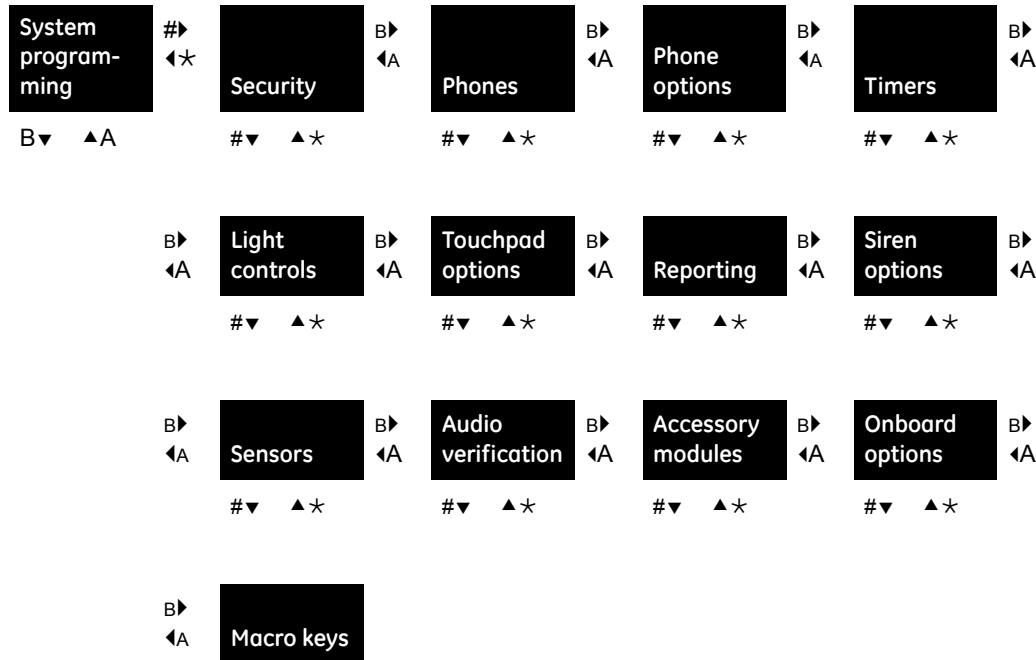

Arrows pointing right or down represent pressing B or # to advance forward through the menus. Arrows pointing left or up represent pressing A or \* to move through the menus in reverse. Only when SYSTEM PROGRAMMING is displayed can you advance to tier 2 menus.

Only when a specific menu is displayed can you advance to those menu settings. For example, from the SENSORS menu pressing # gives you access to learning sensors, programming sensor text, deleting sensors, and viewing/editing sensor programming. Settings in tier 2 menus can also be accessed by entering shortcut numbers. See the section, *Tier 2 programming menus* on page 45 for complete details.

## Exiting programming mode

After all installer/dealer programming is completed, to exit programming mode, do the following:

1. Press \* until the display shows SYSTEM PROGRAMMING.
2. Press A or B until the display shows EXIT PROGRAMMING READY.
3. Press # and the touchpad displays the TIME AND DATE.

## Tier 1 system programming menu

This section guides you through programming tier 1 *System programming* menu items as they appear in sequence. The exact order you follow depends on whether you're installing a new system or changing programming in an existing system.

### Demo kit mode

Default setting is *Off*.

This setting determines whether you use your panel for a standard installation (off) or as a demo kit (on). When the *Demo kit* option is on, only sensors learned into groups 01 and 03, duress code use, and phone test (8 + System Master Code + 2) are reported. Turning on this feature and doing a memory clear changes the following settings:

- Partition 1 master code = 1000
- Partition 2 master code = 2000
- User code 00 = 1001 (partition 1 code—you may use to jump to partition 2)
- User code 01 = 1002 (partition 1 code—you may use to bypass sensors)
- User code 02 = 2001 (partition 2 code—you may use for remote or offsite access)
- User code 03 = 2002 (partition 2 code—you may use to perform system tests)
- User code 04 = 1122 (partition 1 code—you may use to jump to partition 2, for remote or offsite access, and system tests)
- User code 05 = 2233 (partition 2 code—you may use to jump to partition 1, for remote or offsite access, bypassing sensors, and system tests)
- Partition 1 house code = 255 (P)
- Partition 2 house code = 254 (O)
- Zone 1 (hardwired input 1) = group 10, front door
- Zone 2 (hardwired input 2) = group 13, bedroom window
- Zone 3 (hardwired input 3) = group 17, living room motion sensor
- Zone 4 (hardwired input 4) = group 1, panic
- Zone 5 (wireless, keyfob, ID F00201) = group 01, (no text)
- Zone 6 (wireless, DWS, ID A00206) = group 13, kitchen window
- Comm failure = off, Demo kit = on
- AVM code = 1212
- Entry delay = 8 seconds
- Exit delay = 8 seconds
- Extended delay = 1 minute
- Siren timeout = 2 minutes

To turn demo kit mode off or on, do the following:

1. With the display showing *DEMO KIT MODE OFF/ON* (current setting), press **1** (off) or **2** (on), then press **#**.
2. The display flashes the entered setting, then stops after pressing **#** and displays *DEMO KIT MODE OFF/ON* (new setting).

## Partition 1 copy

Default setting is *None*.

After programming all settings pertaining to partition 1, you may make an exact copy to use for partitions 2 to 6. This helps reduce programming time when the system is set up for multiple partitions. If there are certain settings that are unique to partitions 2 to 6, simply advance to the appropriate menu and make the necessary changes.

To copy partition 1, do the following:

1. With the display showing `PARTITION 1 COPY`, press `# + installer code + #`.
2. The display flashes, press `#` and the display shows `DONE`.

## Clear memory

Clearing memory deletes all existing programming information (except the dealer code).

**Note:** Clearing the memory erases onboard hardwired zone factory programming.

To clear panel memory, do the following:

1. With the system in program mode, press **A** or **B** until the display shows `CLEAR MEMORY`.
2. Press `#` and the display shows `ENTER CODE TO CLEAR MEMORY`.
3. Enter the four-digit installer or dealer code (if programmed) + `#`. After about five seconds, the system restarts and the panel scans the bus to learn all bus devices.

If the system doesn't respond as shown, repeat the process.

## Tier 2 programming menus

This section guides you through the following programming tier 2 menu items as they appear in sequence:

- *Security menu* on page 46
- *Phones menu* on page 53
- *Phone options menu* on page 59
- *Timers menu* on page 65
- *Light control menu* on page 70
- *Touchpad options menu* on page 71
- *Reporting menu* on page 73
- *Siren options menu* on page 83
- *Sensors menu* on page 85
- *Audio verification menu* on page 89
- *Accessory modules menu* on page 93
- *Onboard options menu* on page 99
- *Macro keys menu* on page 102

Each menu on tier 2 represents a group of settings related to the menu name. Some tier 2 menus break down into settings that affect the whole system (global) or a specific partition.

To advance to tier 2 program menus from tier 1 *System programming* menu, do the following:

1. With the system in program mode and the display showing `SYSTEM PROGRAMMING`, press # once.
2. The display shows `SECURITY.`, which is the first tier 2 menu.

## Shortcut numbers

To go directly to a setting in tier 2, you can enter the shortcut number for that setting. Shortcut numbers in this manual appear in parentheses, next to the setting name. Menus with partition settings have the series of shortcut numbers in parentheses. Shortcut numbers can be used from any setting location within tier 2.

## Security menu

The *Security* menu lets you choose whether security settings affect the whole system (*Security - global settings*) or a specific partition (*Security partition 1 to 6 settings* on page 50). To access global or partition security menu items, do the following:

1. With the display showing SECURITY, press #. The display should show GLOBAL.
2. Press # again to advance to global settings, or press **A** or **B** to display PARTITION n, then press # to advance to selected partition 1 to 6 settings.

### Security - global settings

This section describes how to program the *Security* settings that appear under *Global*.

#### Downloader code (0000)

Default setting is 12345.

Use the five-digit downloader code in conjunction with downloader programming. The downloader operator must have the panel account number and downloader code in order to perform any programming.

**Note:** You cannot delete the downloader code from the panel memory. To change the downloader code to its default setting, enter 12345 in the procedure to the right. The downloader code resets to defaults during a memory clear only if the dealer code is not set or if the dealer code is used to initiate the memory clear. Downloader programming has not been investigated by UL.

To program a downloader code, do the following:

1. With the display showing DOWNLOADER CODE nnnnn (current code), enter the five-digit code, and press #. The display flashes the entered code.
2. Press # and the display shows the new code.

#### Installer code (0001)

Default setting is 4321.

The four-digit installer code is for entering program mode and changing system settings. If you program a dealer code, only those settings not associated with phone numbers and the downloader code may be changed

**Note:** You may not delete the installer code or clear it from the panel memory. To change the installer code to its default setting, enter 4321.

To program a installer code, do the following:

1. With the display showing INSTALLER CODE (current code), enter the four-digit code. The display flashes the entered code.
2. Press # and the display shows the new code.



## Dealer code (0002)

Default setting is *None*.

The four-digit dealer code is used to prevent unauthorized persons from changing the programmed central station phone numbers and downloader code. When this feature is enabled, central station phone numbers and downloader code cannot be changed (unless you enter the program mode by using the dealer code). All other system settings are still accessible by entering the program mode with the installer code.

**Note:** The dealer code cannot be deleted by clearing panel memory.

To program a dealer code, do the following:

1. With the display showing `DEALER CODE ****`, enter the four-digit code.
2. The display flashes the entered code. Press **#** and the display shows the new code.

To delete a dealer code, do the following:

1. With the display showing `DEALER CODE nnnn` (current code), press **D**.
2. The display shows `DEALER CODE ****`.

## Access code lock (0003)

Default setting is *On*.

This feature determines whether or not the panel includes access codes when sending user information to the automation module. When this option is on, it means the access codes are not sent.

To turn the setting off or on, do the following:

1. With the display showing `ACCESS CODE LOCK ON/OFF`, press **1** (off) or **2** (on).
2. The display flashes the entered setting. Press **#** and the display shows the new setting.

## Partition security (0004)

Default setting is *On*.

This feature controls whether an access code is necessary for partition jumping. When on, you must jump partitions with an access code by pressing **8 + CODE + 6 + PTN**. When off, you may jump partitions without an access code by pressing **7 + 4 + PTN n** (n = 1 to 6).

**Note:** Regardless of the setting, you may always use an access code to jump partitions.

To turn the setting off or on, do the following:

1. With the display showing `PIN SECURITY` (current setting), press **1** (off) or **2** (on).
2. The display flashes the entered setting. Press **#** and the display shows the new setting.

## Multipartition arm/disarm (0004)

Default setting is *Off*. Partition to turn *On*.

This feature controls which partitions can be armed/disarmed simultaneously when using a touchpad and access code assigned to those partitions. When enabled, users can arm/disarm selected partitions using an authorized access code. When disabled, multiple partitions cannot be armed/disarmed simultaneously. For this feature:

- At least two partitions must be selected.
- Touchpads must be assigned to at least one of the selected partitions of this menu.
- Access codes must be assigned to all selected partitions of this menu. If the partition assignment for a specific access code does not match the partitions selected in this menu, only those partitions common to both menu settings can be armed/disarmed simultaneously with that code.
- A partition cannot be armed/disarmed if it is being controlled by another source at that time.
- All arming modifiers except *Silent* affect all partitions being armed. Only the arming partition can be armed silently.
- When arming multiple partitions, any conditions that prevent arming are identified on touchpad displays with the affected partition number flashing. The normal protest/auto force arm sequence follows, or pressing \* cancels the arming request.
- When disarming multiple partitions, any partitions in alarm have the affected partition number flashing on touchpad displays. Pressing # cancels all alarms in the selected partitions. Alarm memory information is then displayed for all canceled alarms.

To enable multipartition arm/disarm, do the following:

1. With the display showing `MULTI-PIN ARM/DISARM_`, press 1 to 6 to enter partitions (at least two).
2. The display flashes the partitions. Press # and the display stops flashing.

To disable multipartition arm/disarm, do the following:

1. With the display showing `MULTI-PTN ARM/DISARM n n n n n n n`, select all of the partitions by entering the appropriate partition number.
2. The partition numbers disappear from the display. Press #.

## Keyfob PTN (0006)

Default setting is *On*.

This feature controls which partitions the selected keyfob can arm/disarm. When enabled, the selected keyfob can arm/disarm the partitions selected in this menu. When disabled, the selected keyfob cannot arm/disarm multiple partitions. For this feature:

- If no keyfobs are learned into panel memory, the menu displays `NOT AVAILABLE`. When keyfobs are learned into panel memory, two submenus appear. The first one lets you view keyfob assignments similar to that of viewing learned sensors. The second submenu lets you view and change the multipartition arming assignments for that keyfob.
- At least two partitions must be selected.
- Keyfobs can arm/disarm multiple partitions only for those partitions set up in the *Multipartition arm/disarm* menu.
- A partition cannot be armed/disarmed if it is being controlled by another source at that time.
- When arming multiple partitions from a keyfob, any conditions that prevent arming are identified on touchpad displays in the partition where that condition exists. Touchpad displays in all other partitions being armed display `PROTEST`. The normal protest/auto force arm sequence follows, or pressing \* on any touchpad in a partition being armed cancels the arming request. Pressing the **Lock** button again during a protest bypasses any open sensors in the affected partitions and arms those partitions.
- When disarming multiple partitions with a keyfob and alarms are active in one or more of the assigned partitions.
  - Protest beeps sound for five minutes in all partitions being disarmed;
  - Partitions in alarm where sirens have timed out sound protest beeps for five minutes;
  - Partitions in alarm with active sirens continue sounding the alarm
- In any case where alarms are active the premises may not be safe to enter. The user has these options:
  - Leave and call for help from a safe location;
  - If entering the premises anyway, go to a hardwired touchpad and check the system status to determine the alarm. Disarm and alarm memory is displayed for all assigned partitions;
  - Press the keyfob **Unlock** button a second time (within the five minute protest period) to disarm all assigned partitions and cancel all alarms, then go to a hardwired touchpad and check alarm memory.

To enable keyfob PTN, do the following:

1. Learn all keyfobs into panel memory. (See *Sensors menu* on page 85.)
2. Enter this menu (display showing `KEYFOB TP PTN`), then press #. The display shows the lowest touchpad sensor number assignment such as: `S1 P1 G0 TP RF` where S1 is sensor 1, P1 is partition 1, G0 is sensor group 0, TP is touchpad and RF is wireless.
3. Press # to accept this keyfob or press **A** or **B** until the desired keyfob appears, then press #. The display shows `ARM PARTITION`.
4. Enter the desired partitions 1 to 6 (at least two). The display flashes the entered partitions.
5. Press # and the display stops flashing.

To disable keyfob PTN, do the following:

1. Enter this menu (display showing `KEYCHAIN TP PTN`), then press `#`. The display shows the lowest touchpad sensor number assignment such as: `S1 P1 G0 TP RF` where `S1` is sensor 1, `P1` is partition 1, `G0` is sensor group 0, `TP` is touchpad and `RF` is wireless.
2. Press `#` to accept this keyfob or press `A` or `B` until the desired keyfob appears, then press `#`. The display shows `ARM PARTITION`.
3. Enter the partition numbers that are displayed (except for the partition you assigned the touchpad when it was learned). Each disappears from the display with the touchpad's original partition number left flashing.
4. Press `#` and the display stops flashing.

## Security partition 1 to 6 settings

The following sections describe the *Security* settings that appear under *Partition 1 to 6*.

### Account number (0010 to 0060)

Default setting is *00000*.

The account number is used as panel (or customer) identification for the central monitoring station. The panel sends the account number every time it reports to the central station. Account numbers must be 1 to 10 characters long.

Alpha characters A to F can be assigned to the account number by pressing and holding buttons 1 to 6 respectively, until the character appears.

**Note:** When using the CID reporting format, the letter A is reported as a 0.

To program an account number, do the following:

1. With the display showing `ACCOUNT NUMBER nnnnn` (current number), enter the account number. The display flashes the entered number.
2. Press `#` and the display shows the new number.

### Quick arm (0011 to 0061)

Default setting is *Off*.

This feature allows system arming without using an access code. When *Quick arm* is on, the system arming level can be increased from *Off* to *Stay*, from *Off* to *Away*, or from *Stay* to *Away*, without entering an access code. A valid access code is still required to decrease the arming level or disarm the system.

To turn the setting off or on, do the following:

1. With the display showing `QUICK ARM OFF/ON` (current setting), press **1** (off) or **2** (on).
2. The display flashes the entered setting. Press `#` and the display shows the new setting.

## Quick exit (0012 to 0062)

Default setting is *On*.

This feature determines whether or not users can open and close a standard entry/exit door without causing an alarm (while the system is armed). This feature also allows you to leave the armed premises without having to disarm and rearm the system. When *Quick exit* is on, pressing **D** on a touchpad (while the system is armed) starts a two-minute timer that allows one standard entry/exit door (sensor groups 10 and 19 only) to be activated once (opened, then closed). When this feature is off, you must disarm the system before any protected door is opened.

To turn the setting off or on, do the following:

1. With the display showing `QUICK EXIT OFF/ON` (current setting), press **1** (off) or **2** (on).
2. The display flashes the entered setting. Press **#** and the display shows the new setting.

## Exit extension (0013 to 0063)

Default setting is *On*.

This feature determines whether you can reenter and exit again through an entry or exit delay door (without disarming and rearming the system). This helps prevent exit faults and false alarms by allowing you to reenter the premises for a forgotten item.

When this feature is on, the panel restarts the exit delay timer if you reenter the premises through a standard delay door before the standard exit delay time expires. When this feature is off, the exit delay timer does not restart if you reenter the premises, forcing you to disarm the system to avoid setting off an accidental alarm.

To turn this setting off or on, do the following:

1. With the display showing `EXIT EXTENSION OFF/ON` (current setting), press **1** (off) or **2** (on).
2. The display flashes the entered setting. Press **#** and the display shows the new setting.

## Keyswitch sensor (0014 to 0064)

Default setting is *None*.

This feature lets you arm and disarm the system using either a keyswitch wired to a hardwired zone input or a wireless door/window sensor.

**Note:** We recommend you program (learn) keyswitch sensors into group 28.

For example, if sensor 1 is designated as the keyswitch sensor and the system is disarmed, then tripping sensor 1 could arm the system to *Away*. If the system is armed to *Stay* or *Away*, then tripping the sensor could disarm the system (depending on keyswitch style).

The panel reports opening, closing, and force armed reports (if turned on) to the central monitoring station.

**Note:** A bypassed keyswitch sensor cannot arm or disarm the system. During an audible alarm, keyswitch sensors can disarm the system (which sends a cancel report to the central monitoring station), but cannot arm the system. The system can be armed only after the siren timeout expires. Keyswitch sensors test the same as any other sensor and do not arm or disarm the system during a sensor test.

To assign a keyswitch sensor, do the following:

1. With the display showing `KEYSWITCH SENSOR nn` (current sensor number), enter the desired sensor number (01–96).
2. The display flashes the entered sensor number. Press **#** and the display shows the new number.

To delete a keyswitch sensor, with the display showing `KEYSWITCH SENSOR nn` (current sensor number), press **D** to erase the keyswitch sensor attribute.

### Keyswitch style (0015 to 0065)

Default setting is *Transition*.

This feature determines how the system behaves when armed/disarmed by a keyswitch sensor. The choices are as follows:

**Transition.** If keyswitch style is set to transition and the keyswitch sensor is tripped (opened) when the system is disarmed, the panel will automatically arm to Away. If the sensor is tripped (opened) when the system is armed to Away or Stay, the panel will automatically disarm.

**State.** If keyswitch style is set to state, when the keyswitch sensor is tripped (opened) the panel arms to Away. If the sensor is restored (closed) the panel disarms.

Opening, closing, and force arming reports (if turned on) are reported to the central station for both keyswitch styles.

To assign a keyswitch style, do the following:

1. With the display showing `KEYSWITCH STYLE TRANSITION/STATE` (current setting), press **1** for *Transition* or **2** for *State*.
2. The display flashes the entered setting. Press **#** and the display shows the new setting.

### Duress code (0016 to 0066)

Default setting is *Transition*.

The duress code is a unique 4-digit access code that allows users to operate the system and, at the same time, instructs the panel to send a silent alarm report to the central station.

Do not use a duress code unless it is absolutely necessary. Using duress codes often results in false alarms due to code entry errors.

**Note:** To use this feature, the *Duress option* setting under the [Reporting menu](#) on page 73 must be turned on.

To program a duress code, do the following:

1. With the display showing `DURESS CODE ****`, enter the desired 4-digit duress code.
2. The display flashes the entered setting. Press **#** and the display shows the new code.

To delete a duress code, do the following:

1. With the display showing `DURESS CODE nnnn` (current code), press **D**.
2. The display shows `DURESS CODE ****`.

## Phones menu

Use the *Phones* menu to set up central station reporting for the system. The *Phones* menu has the following types of submenus:

- Central station phones 1 to 3 (see *Phones central station 1 to 3 settings*)
- Pager phones 1 to 5 (see *Phones - pager phone 1 to 5 settings* on page 56)
- Downloader phone (see *Phones - downloader phone settings* on page 58)

### Phones central station 1 to 3 settings

The following describes how to program the *Phone* menu settings that appear under *CS phone 1 to 3*.

#### Phone number (01000, 01010, and 01020)

Default is *None*.

Use this setting to program the central station receiver phone number. Phone numbers can be 1 to 24 digits long, including pauses or \* and # characters.

- To enter pauses, press **C**.
- To enter \*, press and hold **7** for about two seconds.
- To enter #, press and hold **9** for about two seconds.

**Note:** The phone menus are not accessible if a dealer code is programmed and the installer code is used to enter installer programming mode. To access these menus when a dealer code is programmed, you must enter installer programming mode using the dealer code. Call-waiting services should be disabled to prevent interrupting panel communication to the central monitoring station. To program a dialing prefix that disables call-waiting, see the *Call wait cancel* setting under the menu *Phone options - global settings* on page 59. For UL 1610 and 1635 installations, a phone number must be programmed.

To program a central station phone number, do the following:

1. With the display showing `PHONE NUMBER _` (or current number), enter the desired phone number. The display flashes the entered number.
2. Press **#** and the display shows the new number.

To delete a central station phone number, do the following:

1. With the display showing `PHONE NUMBER` (current number), press **D**.
2. The display shows `PHONE NUMBER _`.

## High level reports (CS phone 1, 01001, CS phone 2, 01011, CS phone 3, 01021)

Default setting for 1 is *On* and *Off* for 2 and 3.

When this setting is on, the following conditions report to the central station:

- Fire, police, auxiliary, and duress alarms
- No activity
- Receiver failure (or jam)
- Tamper conditions, including zone tampers and system tamper (40 incorrect key presses or touchpad supervisory)
- Entering or exiting sensor test mode
- Phone test

**Note:** For UL 1610 and 1635 installations, this feature must be set to on.

To turn high-level reports off or on, do the following:

1. With the display showing HIGH LEVEL RPTS OFF/ON (current setting), press **1** (off) or **2** (on).
2. The display flashes the entered setting. Press **#** and the display shows the new setting.

## Low level reports (01002, 01012, and 01022)

Default setting is *On* for 1 and *Off* for 2 and 3.

When this setting is on, the following nonalarm conditions report to the central station:

- Force armed
- Hardwired zone trouble (open or short)
- Supervisory (wireless devices)
- Low battery (wireless devices)
- Phone test
- Other nonalarm related conditions

**Note:** For UL 1610 & 1635 installations, this feature must be set to on.

To turn low-level reports off or on, do the following:

1. With the display showing LOW LEVEL RPTS OFF/ON (current setting), press **1** (off) or **2** (on).
2. The display flashes the entered setting. Press **#** and the display shows the new setting.

## Exception reports (01003, 01013, and 01023)

Default setting is *Off*.

When this setting is on, the panel reports to the central station if the system is not armed or disarmed at the specified schedule times.

To turn exception reports off or on, do the following

1. With the display showing EXCEPTION RPTS OFF/ON (current setting), press **1** (off) or **2** (on).
2. The display flashes the entered setting. Press **#** and the display shows the new setting.



### Open/close reports (01004, 01014, and 01024)

Default setting is *Off*.

This setting determines whether opening and closing reports are sent to the central station. When turned on, the panel sends a closing report when the system is armed and an opening report when the system is disarmed.

**Note:** To use this feature, the opening reports and closing reports settings under the [Reporting menu](#) on page 73 must be turned on for that partition.

To turn opening/closing reports off or on, do the following:

1. With the display showing OPEN/CLOSE RPTS OFF/ON (current setting), press **1** (off) or **2** (on).
2. The display flashes the entered setting. Press # and the display shows the new setting.

### Backup (01005, 01015, and 01025)

Default setting *On* for 1 and *Off* for 2 and 3.

This setting determines whether or not the panel uses another programmed central station phone number for reporting if attempts with the first number are unsuccessful.

When backup is off, the panel makes up to eight attempts to deliver a report with the programmed phone number. When backup is set to on, the panel makes up to 16 attempts to deliver the report, alternating between the programmed phone number and the backup phone number. Central station phone 1 is backed up by central station phone 2. Central station phones 2 and 3 are backed up by central station phone 1.

To turn backup off or on, do the following:

1. With the display showing BACKUP OFF/ON (current setting), press **1** (off) or **2** (on).
2. The display flashes the entered setting. Press # and the display shows the new setting.

### SIA/CID reporting (01006, 01016, and 01026)

Default setting is *CID*.

This setting determines whether the panel uses the SIA or CID (Contact ID) reporting format for central station communication. To select SIA or CID reporting, do the following:

1. With the display showing REPORTING FORMAT SIA/CID (current setting), press **1** (SIA) or **2** (CID).
2. The display flashes the entered setting. Press # and the display shows the new setting.

### Cellular backup (01007, 01017, and 01027)

Default setting is *On* for 1 and *Off* for 2 and 3.

This setting determines whether the panel uses cellular communication for reporting if attempts using a landline are unsuccessful. To turn cellular backup off or on, do the following:

1. With the display showing CELLULAR BACKUP, press **1** (off) or **2** (on).
2. The display flashes the entered setting. Press # and the display shows the new setting.

## Phones - pager phone 1 to 5 settings

The following describes how to program the *Phones* settings that appear under *Pager phone 1 to 5*.

### Cellular backup (01030, 01040, 01050, 01060, and 01070)

Default setting is *None*.

This feature programs a phone number that communicates to a pager. Phone numbers can be 1 to 24 digits long and include pauses, a skylink number, and 7-digit PIN code.

- To enter pauses, press **C**.
- To enter \*, press and hold **7** for about two seconds.
- To enter #, press and hold **9** for about two seconds

**Note:** Call-waiting services should be disabled to prevent interrupting panel communication to the pagers. To program a dialing prefix that disables call-waiting, see the *Call wait cancel* setting under the [Phone options - global settings](#) on page 59.

To program a pager phone number, do the following:

1. With the display showing PHONE NUMBER \_ (or current number), enter the pager phone number.
2. The display flashes the entered number. Press **#** and the display shows the new setting.

To delete a pager phone number, do the following:

1. With the display showing PHONE NUMBER (current number), press **D**.
2. The display shows PHONE NUMBER \_.

### High level reports (01031, 01041, 01051, 01061, and 01071)

Default setting is *On*.

This setting determines whether the following alarm conditions report to a pager:

- Fire, police, auxiliary, and duress alarms
- No activity
- Receiver failure (or jam)
- Tamper conditions, including zone tampers and system tamper (40 incorrect key presses or touchpad supervisory)
- Entering or exiting sensor test mode
- Phone test

To turn high-level reports off or on, do the following:

1. With the display showing HIGH LEVEL RPTS OFF/ON (current setting), press **1** (off) or **2** (on).
2. The display flashes the entered setting. Press **#** and the display shows the new setting.

### Low level reports (01032, 01042, 01052, 01062, and 01072)

Default setting is *Off*.

This setting determines whether the following nonalarm conditions report to a pager:

- Force armed
- Hardwired zone trouble (open or short)
- Supervisory (wireless devices)
- Low battery (wireless devices)
- Phone test
- Other nonalarm related conditions

To turn low-level reports on or off, do the following:

1. With the display showing `LOW LEVEL RPTS OFF/ON` (current setting), press **1** (off) or **2** (on).
2. The display flashes the setting. Press **#** and the display shows the new setting.

### Exception reports (01033, 01043, 01053, 01063, and 01073)

Default setting is *Off*.

This setting determines whether the panel reports to a pager if the system is not armed or disarmed at the specified schedule times, if open/close reports are turned on. To turn exception reports off or on, do the following:

1. With the display showing `EXCEPTION RPTS OFF/ON` (current setting), press **1** (off) or **2** (on).
2. The display flashes the entered setting. Press **#** and the display shows the new setting.

### Open/close reports (01034, 01044, 01054, 01064, and 01074)

Default setting is *Off*.

This setting determines whether opening and closing reports are sent to a pager. When turned on, the panel sends a closing report when the system arms and an opening report when the system is disarms.

**Note:** To use this feature, the opening reports and closing reports settings under the [Reporting menu](#) on page 73 must be turned on for that partition.

To turn opening/closing reports off or on, do the following:

1. With the display showing `OPEN/CLOSE RPTS OFF/ON` (current setting), press **1** (off) or **2** (on).
2. The display flashes the setting. Press **#** and the display shows the new setting.

### Latchkey reports (01035, 01045, 01055, 01065, and 01075)

Default setting is *On*.

This setting determines whether the panel reports to a pager when the system arms or disarms, according to latchkey time scheduling. To turn latchkey reports off or on, do the following:

1. With the display showing `LATCHKEY RPTS OFF/ON` (current setting), press **1** (off) or **2** (on).
2. The display flashes the entered setting. Press **#** and the display shows the new setting.

## Streamlining (01036, 01046, 01056, 01066, and 01076)

Default setting is *On*.

This setting determines whether the panel includes (off) or excludes (on) the account number when reporting to a pager. To turn streamlining off or on, do the following:

1. With the display showing STREAMLINING OFF/ON (current setting), press **1** (off) or **2** (on).
2. The display flashes the entered setting. Press # and the display shows the new setting.

## Partition assignment (01037, 01047, 01057, 01067, and 01077)

Default setting is *1*.

This setting determines the partition that reports to a pager. All partitions may be set to report to a single pager. To set up partition assignments for pager reporting, do the following:

1. With the display showing PARTITION ASSIGN 1-6 (current setting), press 1 to 6 to select the desired partitions.
2. The display flashes the entered settings. Press # and the display stops flashing.

## Phones - downloader phone settings

The following describes how to program the *Phones* menu settings that appear under *Downloader phone*.

### Phone number (01090)

Default setting is *None*.

Use this setting to enter the phone number of an offsite computer that can be used to program the panel through the phone line. Phone numbers can be 1 to 24 digits long, including pauses or \* and # characters.

- To enter pauses, press **C**.
- To enter \*, press and hold **7** for about two seconds.
- To enter #, press and hold **9** for about two seconds.

**Note:** Call-waiting services should be disabled to prevent interrupting panel communication to the downloader. To program a dialing prefix that disables call-waiting, see the *Call wait cancel* setting under the [Phone options - global settings](#) on page 59.

To program a downloader phone number, do the following:

1. With the display showing PHONE NUMBER (current number), enter the phone number.
2. The display flashes the entered number. Press # and the display shows the new setting.

To delete a downloader phone number, do the following:

1. With the display showing PHONE NUMBER (current number), press **D** to erase the number.
2. The display shows PHONE NUMBER\_.

## Phone options menu

The *Phone options* menu lets you set up system phone access and communication that affect the whole system (see *Phone options - global settings*) or a specific partition.

### Phone options - global settings

The following describe how to program the *Phone options* settings that appear under *Global*.

#### Phone test (02000)

Default setting is *On*.

This setting determines if you can, at any time, test the communication from the panel to the central station or a pager by entering **8 + CODE + 2** (**# + 8 + CODE + 2** from a touch tone phone).

**Note:** For UL 1610 and 1635 listed installations, this feature must be set to on.

To turn the phone test setting off or on, do the following:

1. With the display showing PHONE TEST OFF/ON (current setting), press **1** (off) or **2** (on).
2. The display flashes the entered setting. Press **#** and the display shows the new setting.

#### Automatic phone test (02001)

Default setting is *Off*.

This setting determines if the panel sends a phone test automatically to the central station or a pager on a predetermined schedule. (See *Phone test freq.* and *Next phone test* under *Timers -global settings* on page 65).

**Note:** For UL 1610 and 1635 listed installations, this feature must be set to on.

To turn automatic phone test off or on, do the following:

1. With the display showing AUTO PHONE TEST OFF/ON (current setting), press **1** (off) or **2** (on).
2. The display flashes the entered setting. Press **#** and the display shows the new setting.

#### Automatic test reset (02002)

Default setting is *On*.

This setting determines whether or not the *Automatic phone test* interval is reset after any successful report to the central monitoring station. (See *Phone test freq.* and *Next phone test* under *Timers -global settings* on page 65). When this feature is on, the panel considers any successful report to the central monitoring station to be a successful phone test. Thus, any panel report resets the *Next phone test* setting to the *Phone test freq.* value. The panel only conducts an *Automatic phone test* if no other reports have been made during the *Phone test freq.* time period.

**Note:** *Phone test freq* must be set to 2 or higher for *Auto test reset* to work.

When this feature is off, an *Automatic phone test* is always conducted according to the schedule of the *Phone test freq.* setting, even if the panel makes other reports to the central monitoring station during that time period.

To turn automatic test reset off or on, do the following:

1. With the display showing `AUTO TEST RESET OFF/ON` (current setting), press **1** (off) or **2** (on).
2. The display flashes the entered setting. Press **#** and the display shows the new setting.

### Comm failure (02003)

Default setting is *On*.

This setting determines whether the panel activates trouble beeps to alert users on the premises that communication to the central station failed. Failure notification occurs after the third unsuccessful reporting attempt to the central station/pager. Failure notification can occur immediately if inadequate phone line voltage is detected upon the initial dialing attempt.

**Note:** For UL listed installations, *Comm failure* must be turned on.

To turn the setting off or on, do the following:

1. With the display showing `COMM FAILURE OFF/ON` (current setting), press **1** (off) or **2** (on).
2. The display flashes the entered setting. Press **#** and the display shows the new setting.

### DTMF dialing (02004)

Default setting is *On*.

This setting determines whether the panel uses DTMF tones (on) or pulse (off) for dialing programmed phone numbers. To turn DTMF dialing off or on, do the following:

1. With the display showing `DTMF DIALING OFF/ON` (current setting), press **1** (off) or **2** (on).
2. The display flashes the entered setting. Press **#** and the display shows the new setting.

### Dialer abort delay (02006)

Default setting is *30 seconds*.

This setting determines how much time the user has to abort a panel alarm report.

**Note:** For UL listed systems, the combined time for the *Entry delay* and *Dialer abort delay* must not exceed 60 seconds.

To change the dial abort delay, do the following:

1. With the display showing `DIAL ABORT DELAY nn SECS` (current setting), enter the time (15 to 45 seconds).
2. The display flashes the entered setting. Press **#** and the display shows the new setting.

## Cancel message (02007)

Default setting is *On*.

This setting determines whether or not the panel displays a cancel message after the user disarms the system to clear an alarm condition. To turn cancel message on or off, do the following:

1. With the display showing CANCEL MESSAGE OFF/ON (current setting), press **1** (off) or **2** (on).
2. The display flashes the entered setting. Press **#** and the display shows the new setting.

## Pager delay (02008)

Default setting is *15 seconds*.

This setting determines how long a report is delayed to a pager, after the panel dials the pager number.

**Note:** The *Pager delay* time should not be set below 5 seconds, unless absolutely necessary.

To set the pager delay time, do the following:

1. With the display showing PAGER DELAY nn SECS (current setting), enter a delay time (0 to 30 seconds).
2. The display flashes the entered setting. Press **#** and the display shows the new setting.

## Call wait cancel (02009)

Default setting is *None*.

This feature sets up a dialing prefix to disable the call waiting feature before the panel makes its first dialing attempt to any programmed central monitoring station or downloader phone number. The prefix can be up to eight digits.

- To enter pauses, press **C**.
- To enter \*, press and hold **7** for one second.
- To enter #, press and hold **9** for one second.

**Note:** We recommend that you program two pauses in any *Call wait cancel* dialing prefix to ensure proper operation.

To set up *Call wait cancel*, do the following:

1. With the display showing CALL WAIT CANCEL \_\_\_ (current setting), enter the desired prefix.
2. The display flashes the entered setting. Press **#** and the display shows the new setting.

To delete the *Call wait cancel* prefix, with the display showing CALL WAIT CANCEL \_\_\_ (or current setting), press **D**.



**CAUTION:** Do not change this option from its default until verifying with the customer that he has call waiting with his phone service provider. Changing this option from its default without call waiting will prohibit the panel from calling the central station.

---

## Dial tone detect (02010)

Default setting is *On*.

When this setting is on, the panel begins dialing as soon as it detects a dial tone. When this feature is off, the panel begins dialing a few seconds after seizing the phone line.

**Note:** There is no *Dial tone detect* on the last dialing attempt.

To set up *Dial tone detect*, do the following:

1. With the display showing DIAL TONE DETECT OFF/ON (current setting), press **1** (off) or **2** (on).
2. The display flashes the entered setting. Press # and the display shows the new setting.

## Phone options - partition 1 to 6 settings

The following sections describe the phone options menu settings that appear under *Partition 1 to 6*.

A phone interface/voice module must be installed for the system to use the settings under *Phone options - partition 1 to 6* (except *Line fail delay*).

### Local phone control (0210 to 0260)

Default setting is *On*.

When this feature is on, the panel can be accessed from a phone on the premises. To set up *Local phone control*, do the following:

1. With the display showing LOCAL PHONE CTRL OFF/ON (current setting), press **1** (off) or **2** (on).
2. The display flashes the entered setting. Press # and the display shows the new setting.

### Remote access (0211 to 0261)

Default setting is *On*.

When this setting is on, the panel can be accessed from an offsite phone. To turn remote access off or on, do the following:

1. With the display showing REMOTE ACCESS OFF/ON (current setting), press **1** (off) or **2** (on).
2. The display flashes the entered setting. Press # and the display shows the new setting.

### Ring/hang/ring (0212 to 0262)

Default setting is *On*.

This setting determines how the panel picks up (seizes) the phone line. Select *On* if an answering machine shares the phone line with the panel. Select *Off* if there is no answering machine sharing the phone line with the panel.

**Note:** The *Remote access* setting must be turned on for this feature to work.

When this feature is on, you must use do the following to call the panel:

1. Listen for one or two full rings.



2. Hang up.
3. Call the premises again within the next 10 to 40 seconds. The system answers after the first ring.

When this feature is off, the system answers after 12 full rings.

To turn this feature off or on, do the following:

1. With the display showing RING/HANG/RING OFF/ON (current setting), press **1** (off) or **2** (on).
2. The display begins flashing the entered selection. Press **#** and the display shows the new setting.

### Line fail delay (0213)

Default setting is *None* (partition 1 only).

This setting determines the amount of time the partition 1 phone line voltage must be absent before the panel indicates a phone failure trouble condition. If a delay is *not* programmed (default), the panel will not monitor the phone line voltage.

**Note:** *Line fail delay* is not available for partitions 2 to 6 at this time.

To set the *Line fail delay* time, do the following:

1. With partition 1 selected, press **A** or **B** until the display shows LINE FAIL DELAY nn SECS (current setting).
2. Enter the time value (10 to 240 seconds).
3. The display flashes the entered setting. Press **#** and the display shows the new setting.

To delete the *Line fail delay* time, do the following:

1. With partition 1 selected, press **A** or **B** until the display shows LINE FAIL DELAY nn SECS (current setting).
2. Press **D** to delete the current *Line fail delay* time.

### Toll saver (0214 to 0264)

Default setting is *On*.

This setting determines whether the panel answers a phone call on the eighth ring (on) or twelfth ring (off) when a trouble or alarm condition exists. To turn the setting off or on, do the following:

1. With the desired partition selected, press **A** or **B** until the display shows TOLL SAVER OFF/ON (current setting). Press **1** (off) or **2** (on).
2. The display flashes the entered setting. Press **#** and the display shows the new setting.

## Phone panic (0216 to 0266)

Default setting is *Off*.

This setting determines whether or not a police panic alarm can be activated from a touch tone phone. When this feature is on, pressing # + \*\*\*\*\* from a touch tone phone on the premises causes a panic alarm.

To turn the setting off or on, do the following:

1. With the desired partition selected, press **A** or **B** until the display shows PHONE PANIC OFF/ON (current setting). Press **1** (off) or **2** (on).
2. The display flashes the entered setting. Press # and the display shows the new setting.

## Phone access key (0216 to 0265)

Default setting is #.

This setting determines which touch tone phone button is used for system access and control. If the local phone control feature is enabled, the user can pick up the phone and press # (within 5 seconds) to access the security system. The panel seizes the phone line and waits for the user to enter system commands. Phone access can be changed from # to \*.

**Note:** Use the default setting (#) to avoid conflicts between the security system and other phone devices and services. Many phone devices and services require \* to initiate their operation, so using \* for this security feature could cause conflicts.

To change the *Phone access key*, do the following:

1. With the desired partition selected, press **A** or **B** until the display shows PHONE ACCESS KEY #/\* (current setting). Press **1** (\*) or **2** (#).
2. The display flashes the entered setting. Press # and the display shows the new setting.

## Timers menu

Use the *Timers* menu to set up the various system feature times that affect the whole system (see *Timers -global settings*) or a specific partition (*Timers - partition 1 to 6 settings* on page 67).

### Timers -global settings

The following describes how to program the *Timers* menu settings that appear under *Global*.

#### Supervisory time (0300)

Default setting is set randomly between 01:00 and 4:00.

This setting determines what time of day the panel sends supervisory, low battery, or automatic phone test reports to the central station.

**Note:** The panel clock must be set with the correct time for accurate supervisory time reporting. See *Time and date menu* on page 104.

To set the *Supervisory time*, do the following:

1. With the display showing SUPERVISORY TIME HH:MM (current setting), enter the 4-digit time value. For example, enter 0330 to set the supervisory time for 3:30 a.m.
2. The display flashes the entered setting. Press # and the display shows the new setting.

#### RF Tx timeout (0302)

Default setting is 12 hours.

This setting determines how many hours (2 to 24) the panel has to receive at least one signal from a wireless sensor (learned into a supervised group). If the panel does not receive a signal from any supervised wireless sensor within the set time, the panel reports a supervisory condition to the central station.

**Note:** For UL 985, 1610 and 1635 listed installations, the *RF Tx timeout* must be set to 4 hours. For UL 1023 listed installations, the *RF Tx timeout* must be set to 24 hours.

To set the *RF Tx timeout*, do the following:

1. With the display showing RF TX TIMEOUT nn HOURS (current setting), enter the timeout value (2 to 24 hours).
2. The display flashes the entered setting. Press # and the display shows the new setting.

### Phone test freq. (0303)

Default setting is *7 days*.

This setting determines how often the panel conducts the automatic phone test (see *PHONE OPTIONS - GLOBAL SETTINGS* on page 59). The system can be set to perform an automatic phone test anywhere from every day to every 255 days.

**Note:** For UL 1610 and 1635 listed installations, this feature must be set to 1.

To set the *Phone test freq.*, do the following:

1. With the display showing PHONE TEST FREQ nnn DAYS (current setting), enter the number of days (1 to 255).
2. The display flashes the entered setting. Press # and the display shows the new setting.

### Next phone test (0304)

Default setting is *7 days*.

This setting is used by the *Automatic phone test* feature under *Phone options - global settings* on page 59 to determine when the next automatic phone test should occur. This setting should be the same as, or less than, the *Phone test freq.* setting.

**Note:** For UL 1610 and 1635 listed installations, this feature must be set to 1.8.

To set the *Next phone test*, do the following:

1. With the display showing NEXT PHONE TEST nnn DAYS (current setting), enter the number of days (1 to 255).
2. The display flashes the entered setting. Press # and the display shows the new setting.

### Output trip time (0305)

Default setting is *4 seconds*.

This setting determines how long outputs are activated when tripped (if they are configured for a momentary response). To set the *Output trip time*, do the following:

1. With the display showing OUTPUT TRIP TIME nn SECS (current setting), enter the number of seconds (1 to 12).
2. The display flashes the entered setting. Press # and the display shows the new setting.

## Activity timeout (0306)

Default setting is *24 hours*.

This setting determines when the system sends a *no activity* report. The panel can be set to wait from 1 to 42 hours. If no user interaction or device activation occurs in that time, the panel sends a report to the central station. To set the *Activity timeout*, do the following:

1. With the display showing `ACTIVITY TIMEOUT nn HOURS` (current setting), enter the number of hours (1 to 42).
2. The display flashes the entered setting. Press `#` and the display shows the new setting.

## Daylight saving (0307)

Default setting is *On*.

When this setting is on, the panel clock automatically adjusts for daylight saving time changes. To turn daylight saving off or on, do the following:

1. With the display showing `DAYLIGHT SAVING OFF/ON` (current setting), press **1** (off) or **2** (on).
2. The display flashes the entered setting. Press `#` and the display shows the new setting.

## Timers - partition 1 to 6 settings

The following sections describe the *Timers* menu settings that appear under *Partition 1 to 6*.

### Entry delay (0310 to 0360)

Default setting is *30 seconds*.

This setting determines how much time you have to disarm the system (after entering the armed premises through a *designated delay door*) without causing an alarm.

**Note:** For UL 1023 listed installations, the *Entry delay* must be set to 45 seconds or less. The combined time for the *Entry delay* and *Dialer abort delay* (02006) must not exceed 60 seconds.

To set the *Entry delay*, do the following:

1. With the display showing `ENTRY DELAY nnn SECS` (current setting), enter the time value (30 to 240 seconds).
2. The display flashes the entered setting. Press `#` and the display shows the new setting.

### Exit delay (0311 to 0361)

Default setting is *60 seconds*.

This setting determines how much time you have (after arming the system) to leave the premises through a *designated delay door* without causing an alarm.

**Note:** For UL 1023 listed installations, this feature must be set to 60 seconds or less. For UL 1610 listed installations, this feature must be set to 120 seconds or less.

To set the *Exit delay*, do the following:

1. With the display showing EXIT DELAY nnn SECS (current setting), enter the time value (45 to 184 seconds).
2. The display flashes the entered setting. Press # and the display shows the new setting.

### Extended delay (0312 to 0362)

Default setting is *4 minutes*.

This setting determines how much time you have (after arming the system) to enter *or* exit the premises through a *designated extended delay door* (1 to 8 minutes).

**Note:** For UL listed installations, you may not use *Extended delay*.

To set the extended delay, do the following:

1. With the display showing EXTENDED DELAY n MINUTES (current setting), enter the time value (1 to 8 minutes).
2. The display flashes the entered setting. Press # and the display shows the new setting.

### Siren timeout (0313 to 0363)

Default setting is *4 minutes*.

This setting determines how long sirens sound (1 to 30 minutes) if no one is present to disarm the system.

**Note:** For UL listed installations, the *Siren timeout* must be set to 4 minutes or more.

To set the siren timeout, do the following:

1. With the display showing SIREN TIMEOUT nn MINUTES (current setting), enter the time value (1 to 30 minutes).
2. The display flashes the entered setting. Press # and the display show the new setting.

### Sleep time (0314 to 0364)

Default setting is *22:00* (10:00 p.m.).

This setting determines the start time and restart of a 10-hour window during which trouble beeps are suppressed. The initial occurrence of an event that causes trouble beeps within this window does not sound trouble beeps until the *Sleep time* window expires. If trouble beeps from a previous event are due to be restarted during the sleep time window, they restart one hour prior to *Sleep time*.

**Note:** For UL listed installations, this feature must be set to off.

To set the *Sleep time*, do the following:

1. With the display showing SLEEP TIME hh:mm (current setting), enter the time value (00:00 to 23:50 using 10 minute intervals).
2. The display flashes the entered setting. Press # and the display shows the new setting.

To turn off *Sleep time*, with the display showing SLEEP TIME hh:mm (current setting), press **D**.

## No usage time (0315 to 0365)

Default setting is *None*.

This setting determines how many days a partition can remain disarmed before the panel sends a no usage report to the central monitoring station and stores the event in the history buffer.

When this feature is set:

- This timer decreases by one at *STIME* each day the selected partition remains disarmed.
- If the timer gets to 0 at *STIME*, the panel sends a *no usage* report to the central monitoring station and stores the event in the history buffer.
- If the partition is armed before the timer reaches 0, the timer resets to the programmed setting.

When this feature is not set (default), the panel does not send or log *no usage* reports.

To set the *No usage time*, do the following:

1. With the display showing *NO USAGE TIME* (current setting), enter the number in days (2 to 255).
2. The display flashes the entered setting. Press # and the display show the new setting.

To turn off *No usage time*, with the display showing *NO USAGE TIME* (current setting), press **D**.

## Light control menu

The *Light control* menu lets you set up light activation for a specific partition.

**Note:** For light control to work, you must power the panel with a power line carrier transformer and X10 powerhouse lamp modules must be installed at desired lamps.

### Light control - partition 1 to 6 settings

The following describes how to program the *Light control* menu settings that appear under *Partition 1 to 6*.

#### Entry lights (0400 to 0450)

Default setting is *None*.

This setting determines which X10 controlled lights turn on during entry and exit delays.

**Note:** X10 lamp modules set to 1 always turn on during the entry and exit delays. X10 lamp modules set to 2 always flash the arming level when arming the system. For example, lights flash two times when arming to STAY (level 2), and three times when arming to AWAY (level 3).

To set the entry lights, do the following:

1. With the desired partition selected, press #. The display shows ENTRY LIGHTS nnnnnnn (current setting).
2. Enter all the desired light numbers (3 to 9) based on the unit dial setting on each X10 lamp module.
3. The display flashes the entered settings. Press # and the display shows the new settings.

To delete entry lights, enter any light number that appears on the display, then press #. The number disappears from the display.

#### House code (0401 to 0451)

Default setting is *01 B* for partition 1, *02 C* for partition 2, *03 D* for partition 3, *04 E* for partition 4, *05 F* for partition 5, and *06 G* for partition 6.

This setting enables X10 controlled lights to work in a selected partition without interfering with the X10 controlled lights of the other partitions. After setting the panel house code for each partition, you must set the X10 controlled lights for that partition to the same house code. The letter that appears automatically after the house code number indicates the necessary house dial setting for X10 modules in that partition.

To set the House code, do the following:

1. After you select your partition, press **A** or **B** until the display shows HOUSE CODE nn-x (current setting). Enter the number (1 to 255).
2. The display flashes the entered number. Press # and the display shows the new house code.



## Touchpad options menu

The *Touchpad options* menu lets you set up touchpad panic and arming operations that affect the whole system (see *Touchpad options - global settings*) or a specific partition (*Touchpad options - partition 1 to 6 settings*).

### Touchpad options - global settings

The following section describes the *Touchpad options* menu settings that appear under *Global*.

#### Latchkey zones (0500)

Default setting is *None*.

This setting defines the range of keyfobs that will function as latchkey users. The value you enter in this section may be any valid zone number. When you enter a zone number, all zones *at* or *below* that zone number function as latchkey users. For example, if you enter 5, any keyfobs learned into zones 1 to 5 will be latchkey users and all others (6 to 96) will not.

To set the number of latchkey zones, do the following:

1. With the display showing `LATCHKEY ZONES nnn` (current setting), enter the number of latchkey zones (1 to 96).
2. The display flashes the setting. Press `#` and the display shows the new setting.

To delete or disable latchkey zones, with the display showing `LATCHKEY ZONES nnn` (current setting), press **D**.

### Touchpad options - partition 1 to 6 settings

The following sections describe the *Touchpad options* menu settings that appear under *Partition 1 to 6*.

#### Fire panic (0510 to 0560)

Default setting is *On*.

This setting determines whether touchpad fire panic buttons are enabled (on) or disabled (off). To change the *Fire panic* setting, do the following:

1. With the display showing `FIRE PANIC OFF/ON` (current setting), press **1** (off) or **2** (on).
2. The display flashes the entered setting. Press `#` and the display shows the new setting.

#### Aux. panic (0511 to 0561)

Default setting is *On*.

This setting determines whether touchpad auxiliary panic buttons are enabled (on) or disabled (off). To change the auxiliary panic setting, do the following:

1. With the display showing `AUXILIARY PANIC OFF/ON` (current setting), press **1** (off) or **2** (on).
2. The display flashes the entered setting. Press `#` and the display shows the new setting.

### Police panic (0512 to 0562)

Default setting is *On*.

This setting determines whether touchpad police panic buttons are enabled (on) or disabled (off). To change the setting, do the following:

1. With the display showing `POLICE PANIC OFF/ON` (current setting), press **1** (off) or **2** (on).
2. The display flashes the entered setting. Press **#** and the display shows the new setting.

### Keyfob (keychain TP) arm (0513 to 0563)

Default setting is *Off*.

When this setting is on, pressing the lock button on keyfob arms the system directly to *AWAY* with *No delay*. When this setting is off, each key press increments the arming level (for example, from *OFF* to *STAY*, from *STAY* to *AWAY*).

To change the setting, do the following:

1. With the display showing `KEYCHAIN TP ARM OFF/ON` (current setting), press **1** (off) or **2** (on).
2. The display flashes the entered setting. Press **#** and the display shows the new setting.

### Star is no delay (0514 to 0564)

Default setting is *Off*.

This setting determines whether the keyfob star button controls an output (off) or the *No delay* feature (on).

To change the setting, do the following:

1. With the display showing `STAR IS NO DELAY OFF/ON` (current setting), press **1** (off) or **2** (on).
2. The display flashes the entered setting. Press **#** and the display shows the new setting.

## Reporting menu

The *Reporting* menu lets you set up which system events are reported to the central monitoring station that affect the whole system (see *Reporting - global settings*) or a specific partition (*Reporting - partition 1 to 6 settings* on page 78).

### Reporting - global settings

The following describes how to program the *Reporting* menu settings that appear under *Global*.

#### 24-hour tamper (06000)

Default setting is *Off*.

When this setting is turned on, the panel sounds sirens and reports a tamper alarm (even when the system is disarmed), when nonfire wireless sensor tamper switches are activated.

When this setting is turned off, the panel sounds sirens and reports a tamper alarm only when nonfire wireless sensor tamper switches are activated and those sensors are active for the current arming level. For nonfire sensors not active in the current arming level that have their tamper switch activated, trouble beeps sound and the panel sends a sensor tamper report to the central station if the *System tamper* feature is on for that partition.

**Note:** Tamper conditions for fire sensors (group 26) always cause trouble beeps to sound and report the tamper condition to the central station, regardless of this feature setting. For commercial UL listed installations (UL 1610) the *24-hour tamper* must be set to on.

To turn the setting off or on, do the following:

1. With the display showing 24 HOUR TAMPER OFF/ON (current setting), press **1** (off) or **2** (on).
2. The display flashes the entered setting. Press **#** and the display shows the new setting.

#### Antenna tamper (06001)

Default setting is *Off*.

This setting determines whether the panel monitors for antenna tamper of onboard and all connected bus transceivers and receivers. When turned on, the panel sounds trouble beeps in all partitions and reports an antenna tamper condition. Touchpads in all partitions show a receiver tamper trouble condition. When turned off, the panel ignores antenna tampers.

**Note:** If the system includes SuperBus 2000 RF receivers, this setting must be off.

To turn the setting off or on, do the following:

1. With the display showing ANTENNA TAMPER OFF/ON (current setting), press **1** (off) or **2** (on).
2. The display flashes the entered setting. Press **#** and the display shows the new setting.

### Buffer control (06002)

Default setting is *Off*.

When this setting is on, only arming level changes and time changes (system time and daylight saving time) are logged in the buffer (memory) of the panel. When this setting is off, all system events are logged in the buffer.

To turn the setting off or on, do the following:

1. With the display showing `BUFFER CONTROL OFF/ON` (current setting), press **1** (off) or **2** (on).
2. The display flashes the entered setting. Press **#** and the display shows the new setting.

### Back in service (06003)

Default setting is *On*.

When this setting is on, the panel reports to the central station when AC and backup battery power are restored (after an extended power outage).

To turn the setting off or on, do the following:

1. With the display showing `BACK IN SERVICE OFF/ON` (current setting), press **1** (off) or **2** (on).
2. The display flashes the entered setting. Press **#** and the display shows the new setting.

### Bypass reports (06004)

Default setting is *Off*.

When this setting is on, the panel reports to the central station whenever sensors or zones are bypassed.

To turn the setting off or on, do the following:

1. With the display showing `BYPASS REPORTS OFF/ON` (current setting), press **1** (off) or **2** (on).
2. The display flashes the entered setting. Press **#** and the display shows the new setting.

### Low CPU battery (06005)

Default setting is *On*.

When this setting is on, the panel reports a low panel battery to the central station when the system battery test fails. If this setting and the *Aux power fail* feature are both on, the panel also monitors for and reports a low battery for the SuperBus 2000 2-amp power supply.

**Note:** For UL 1635 listed installations, the *Low CPU battery* feature must be set to on.

To turn the setting off or on, do the following:

1. With the display showing `LOW CPU BATTERY OFF/ON` (current setting), press **1** (off) or **2** (on).
2. The display flashes the entered setting. Press **#** and the display shows the new setting.

## Battery restoral (06006)

Default setting is *Off*.

If this setting is on, the panel reports to the central monitoring station when a wireless sensor or touchpad reports a battery replacement to the panel.

To turn the setting off or on, do the following:

1. With the display showing BATTERY RESTORAL OFF/ON (current setting), press **1** (off) or **2** (on).
2. The display flashes the entered setting. Press # and the display shows the new setting.

## Buffer full report (06007)

Default setting is *Off*.

When this setting is on, the panel sends an *event buffer full* report to the central monitoring station when the event buffer is nearing full. When turned off, no report is sent.

To turn the setting off or on, do the following:

1. With the display showing BUFFER FULL RPT OFF/ON (current setting), press **1** (off) or **2** (on).
2. The display flashes the entered setting. Press # and the display shows the new setting.

## Zone restorals (06008)

Default setting is *Off*.

When this setting is on, the panel reports a restoral to the central monitoring station for wireless or hardware zones in alarm before the alarm is canceled.

**Note:** As with all GE Security panels, hardwired smoke detectors connected to panel or SnapCard hardwired zones do not send restorals.

To turn the setting off or on, do the following:

1. With the display showing ZONE RESTORALS OFF/ON (current setting), press **1** (off) or **2** (on).
2. The display flashes the entered setting. Press # and the display shows the new setting.

## Two-trip (06009)

Default setting is *Off*.

This setting works with the *Alarm verify* setting (see [Alarm verify \(06108 to 06608\)](#) on page 81 and [Appendix C, Reference tables](#)). If *Alarm verify* is on, the panel waits for a second sensor trip before sending an alarm.

**Note:** For UL listed installations, the *Two trip* error feature must be off.

If *Two-trip* is on and a second sensor trip *does not occur* within a four-minute time period, the panel sends an error report to the central monitoring station. To turn the setting off or on, do the following:

1. With the display showing TWO-TRIP ERROR OFF/ON (current setting), press **1** (off) or **2** (on).
2. The display flashes the entered setting. Press # and the display shows the new setting.

## TP panic TRPT FMT (06010)

Default setting is *Off*.

This setting determines how the panel formats touchpad panic alarm reports to the central station. When this feature is turned on, touchpad panic alarms report using the following 3-digit codes:

- Auxiliary—597
- Police—598
- Fire—599

When turned off, touchpad panic alarms report using a 3-digit code from 500 to 515, with the last 2 digits identifying the touchpad device number.

To turn the setting off or on, do the following:

1. With the display showing TP PANIC RPT FMT OFF/ON (current setting), press **1** (off) or **2** (on).
2. The display flashes the entered setting. Press # and the display shows the new setting.

## AC failure (06011)

Default setting is *Off*.

When this setting is on, the panel reports to the central station at a random time between 15 and 45 minutes after AC power to the panel is lost. Making the report random helps prevent systems in an area affected by a power outage from trying to report at the same time.

**Note:** If this feature and the *Aux power fail* feature are both on, the panel also monitors for and reports an AC failure for the SuperBus 2000 2-amp power supply. For UL listed installations, *AC failure* must be set to on.

To turn the setting off or on, do the following:

1. With the display showing AC FAILURE OFF/ON (current setting), press **1** (off) or **2** (on).
2. The display flashes the entered setting. Press # and the display shows the new setting.

## Receiver failure (06012)

Default setting is *Off*.

When this setting is on, the panel reports a receiver failure under the following conditions:

- No wireless sensor signals have been received for two hours.
- The receiver is being jammed with a constant signal.

**Note:** For UL listed installations using wireless devices, *Receiver failure* must be set to on.

To turn the setting off or on, do the following:

1. With the display showing RECEIVER FAILURE OFF/ON (current setting), press **1** (off) or **2** (on).
2. The display flashes the entered setting. Press # and the display shows the new setting.

### RF low battery report (06013)

Default setting is *Weekly*.

This setting determines whether the panel sends daily or weekly low battery reports to the central monitoring station when a wireless device is reporting a low battery condition to the panel.

To set *RF low battery report* to daily or weekly, do the following:

1. With the display showing RF LOW BAT RPT DAILY/WEEKLY (current setting), press **1** (daily) or **2** (weekly).
2. The display flashes the entered setting. Press **#** and the display shows the new setting.

### RF supv report (06014)

Default setting is *Weekly*.

This setting determines whether the panel sends daily or weekly reports to the central monitoring station when the panel detects a supervisory condition in a wireless device.

To set *RF Supv Report* to daily or weekly, do the following:

1. With the display showing RF SUPV REPORT DAILY/WEEKLY (current setting), press **1** (daily) or **2** (weekly).
2. The display flashes the entered setting. Press **#** and the display shows the new setting.

### Swinger limit (06015)

Default setting is *1*.

This setting determines the maximum number of times (1 or 2) a sensor or zone can go into alarm (during a single arming period) before the panel automatically bypasses that sensor or zone. This feature only applies to sensors or zones in groups 00–20, 29, 34, 35, or 38.

When set to 1, the panel automatically bypasses a sensor or zone after it causes an alarm. When set to 2, the panel waits until a sensor or zone has caused a second alarm (during the same arming period) before bypassing it. At any setting, the automatic bypass is logged into the event buffer.

A bypassed sensor or zone will be cleared (automatically unbypassed) if the system receives no further activations from that sensor or zone over the next 48 to 50 hours.

Changing the arming level also clears all automatically bypassed sensors and zones and resets the *Swinger limit* count on all sensors and zones.

To set the *Swinger limit*, do the following:

1. With the display showing SWINGER LIMIT n (current setting), press the desired number (1 or 2).
2. The display flashes the entered setting. Press **#** and the display shows the new setting.

## Aux power fail (06016)

Default setting is *On*.

When this setting is on, the panel sends a report to the central monitoring station if the 12 VDC power outputs on the panel and/or SuperBus 2000 2-amp power supply fail.

**Note:** If this feature is on and the *AC failure* and *Low CPU battery* features are both on, the panel sends AC failure and low backup battery reports for the SuperBus 2000 2-amp power supply.

To turn the setting off or on, do the following:

1. With the display showing AUX POWER FAIL ON/OFF (current setting), press **1** (off) or **2** (on).
2. The display flashes the entered setting. Press # and the display shows the new setting.

## Ground fault (06017)

Default setting is *On*.

When this setting is on, the panel will annunciate and send a report to the central monitoring station if it detects current flow between the panel's circuitry and the chassis. This indicates that a short to earth ground exists somewhere in the system.

**Note:** This feature must be on if hardwired smoke sensors are used in this system.

To turn the setting off or on, do the following:

1. With the display showing GROUND FAULT OFF/ON (current setting), press **1** (off) or **2** (on).
2. The display flashes the entered setting. Press # and the display shows the new setting.

## Reporting - partition 1 to 6 settings

The following describes the *Reporting* menu settings that appear under *Partition 1 to 6*.

### Opening reports (06100 to 06600)

Default setting is *Off*.

When this setting is on, the panel sends an opening report to the central station after disarming the system.

**Note:** To use this feature, the *Open/close reports* settings under the *Phones menu* on page 53 must be turned on for the specific CS phone or pager number.

To turn the setting off or on, do the following:

1. With the display showing OPENING REPORTS OFF/ON (current setting), press **1** (off) or **2** (on).
2. The display flashes the entered setting. Press # and the display shows the new setting.

### Closing reports (06101 to 06601)

Default setting is *Off*.

When this setting is on, the panel sends a closing report to the central station after arming the system.



**Note:** To use this feature, the *Open/close reports* settings under the [Phones menu](#) on page 53 must be turned on for the specific CS phone or pager number.

To turn the setting off or on, do the following:

1. With the display showing `CLOSING REPORTS OFF/ON` (current setting), press **1** (off) or **2** (on).
2. The display flashes the entered setting. Press **#** and the display shows the new setting.

### No activity option (06102 to 06601)

Default setting is *Off*.

When this setting is on, the panel sends a no activity report to the central station when the activity timeout expires (see *TIMERS—ACTIVITY TIMEOUT*).

To turn the setting off or on, do the following:

1. With the display showing `NO ACTIVITY OFF/ON` (current setting), press 1 (off) or 2 (on). The display flashes the entered setting.
2. Press **#** and the display shows the new setting.

### Duress option (06103 to 06603)

Default setting is *Off*.

When this setting is on, the system can be controlled using a programmed duress code (see [Security partition 1 to 6 settings](#) on page 50) and will send a duress alarm to the monitoring station.

**Note:** For UL listed installations, *Duress option* must be set to off.

Do not use a duress code unless it is absolutely necessary. Using duress codes often results in false alarms due to code entry errors. If a duress code *is* absolutely necessary, use it with the audio verification module to reduce false alarms and accidental dispatches. The audio verification module is listen only.

To turn the setting off or on, do the following:

1. With the display showing `DURESS OFF/ON` (current setting), press **1** (off) or **2** (on).
2. The display flashes the entered setting. Press **#** and the display shows the new setting.

### Force armed (06104 to 06604)

Default setting is *Off*.

When this setting is on, the panel reports to the central monitoring station when you “force arm” the system.

**Note:** Forced arming occurs if you press BYPASS when arming the system with open sensors/zones protesting. Auto-forced arming occurs when you do not press BYPASS when arming the system with open sensors/zones protesting, then leave through an entry/exit door and the arming protest period expires. This causes the system to automatically bypass the open (protesting) sensors. Autoforced arming always reports to the central monitoring station. Autoforced arming has not been investigated by UL.

To turn the setting off or on, do the following:

1. With the display showing FORCE ARMED OFF/ON (current setting), press **1** (off) or **2** (on).
2. The display flashes the entered setting. Press # and the display shows the new setting.

### Latchkey format (06105 to 06605)

Default setting is *Off*.

This setting determines whether the selected partition is set up for basic (off) or advanced (on) latchkey opening report operation.

**Basic.** If the partition is armed by entering **2** (or 3) + **CODE**, disarming using a designated latchkey user code or keyfob within an assigned time schedule sends a page.

Arming the partition by entering **2** (or 3) + **CODE** + **6** (Latchkey) sends a page.

If the partition is armed by entering **2** (or 3) + **CODE** + **6** (Latchkey), disarming using a designated latchkey user code or keyfob inside or outside of an assigned time schedule sends a page.

**Advanced.** Arming the partition by entering **2** (or 3) + **CODE** + **6** (Latchkey) within an assigned time schedule sends a page.

Refer to the *Concord 4 User Manual* for complete latchkey setup and operation.

To turn the setting off or on, do the following:

1. With the desired partition selected, press **A** or **B** until the display shows LATCHKEY FORMAT OFF/ON (current setting). Press **1** (off—basic) or **2** (on—advanced).
2. The display flashes the entered setting. Press # and the display shows the new setting.

### Freeze alarm (06106 to 06606)

Default setting is *Off*.

This setting determines whether the panel reports a freeze alarm to the central station or pager, when the selected partition’s energy saver module detects a temperature that matches a predetermined setting.

To turn the setting off or on, do the following:

1. With the desired partition selected, press **A** or **B** until the display shows FREEZE ALARM OFF/ON (current setting). Press **1** (off) or **2** (on).
2. The display flashes the entered setting. Press # and the display shows the new setting.

## Freeze temp (06107 to 06607)

Default setting is  $42^{\circ}\text{F}$ .

This setting determines the temperature point the EnergySaver module detects a potential freeze (heating failure) condition. The adjustable range is from 40 to  $90^{\circ}\text{F}$ .

**Note:** This is the same menu found under [Accessory modules - bus devices settings](#) on page 93.

To set the *Freeze temp*, do the following:

1. With the desired partition selected, press **A** or **B** until the display shows FREEZE TEMP (current setting). Enter the desired temperature (40 to  $90^{\circ}\text{F}$ ).
2. The display flashes the entered setting. Press # and the display shows the new setting.

## Alarm verify (06108 to 06608)

Default setting is *Off*.

This setting determines whether the panel reports to the central monitoring station after a single sensor or zone trip (off) or waits for a second trip before reporting (on).

This setting affects sensors/zones in groups 10 through 20. If *Alarm verify* is on, group 18 responds the same as group 17 (See [Appendix A, System planning sheets](#)).

**Note:** For UL listed installations, *Alarm verify* must be off.

To turn the setting off or on, do the following:

1. With the display showing ALARM VERIFY OFF/ON (current setting), press **1** (off) or **2** (on).
2. The display flashes the entered setting. Press # and the display shows the new setting.

## System tamper (06109 to 06609)

Default setting is *Off*.

This setting determines how the panel handles possible tamper situations. When this feature is on, the panel reacts as follows:

- Initiates an alarm when the system prompts for an access code (arming/disarming, etc.) and several wrong access codes are entered (40 consecutive invalid keypresses).
- Reports to the central station if a bus device stops communicating with the panel.
- Reports to the central monitoring station if a tamper condition occurs on unarmed RF (wireless) devices.

**Note:** For UL commercial listed installations (UL 1610), *System tamper* must be on.

To turn the setting off or on, do the following:

1. With the display showing SYSTEM TAMPER OFF/ON (current setting), press **1** (off) or **2** (on).
2. The display flashes the entered setting. Press # and the display shows the new setting.

## Report confirm (06111 to 06611)

Default setting is *Off*.

When this setting is on, system status speakers announce “Report is okay” followed by a single beep each time a successful report is made to the central monitoring station. When turned off, no status message or beep sounds.

To turn the setting off or on, do the following:

1. With the display showing REPORT CONFIRM OFF/ON (current setting), press **1** (off) or **2** (on).
2. The display flashes the entered setting. Press **#** and the display shows the new setting.

## Siren options menu

The *Siren Options* menu lets you set up siren operation and supervision that affect the whole system (see *Siren options - global settings*) or a specific partition (*Siren options - Partition 1 setting* on page 84).

### Siren options - global settings

The following describes how to program the *Siren options* menu settings that appear under *Global*.

#### Immediate beeps (0700)

Default setting is *Off*.

This setting determines whether the panel activates trouble beeps as soon as a wireless device supervisory condition is detected (on), or if the panel waits 10 hours after the supervisory condition is detected to activate trouble beeps (off). (See *Timers -global settings* on page 65).

**Note:** For UL listed installations, this feature must be on.

To turn the setting off or on, do the following:

1. With the display showing IMMEDIATE BEEPS OFF/ON (current setting), press **1** (off) or **2** (on).
2. The display flashes the entered setting. Press # and the display shows the new setting.

#### Disable trouble beeps (0701)

Default setting is *Off*.

When you turn on this setting, the panel does not initiate beeps to alert users of nonfire wireless device supervisory trouble and does not protest on arming if the condition exists.

**Note:** If *Immediate beeps* is on, trouble beeps sound for supervisory trouble conditions regardless of this menu setting. For UL listed installations, *Disable trouble beeps* must be off.

To turn the setting off or on, do the following:

1. With the display showing DISABLE TR BEEPS OFF/ON (current setting), press **1** (off) or **2** (on).
2. The display flashes the entered setting. Press # and the display shows the new setting.

#### UL 98 options (0702)

Default setting is *Off*.

This setting determines whether the panel complies with UL 98 requirements (4-hour trouble beep restart, 4-hour backup battery test, 4-hour smoke (group 26) zone supervisory).

**Note:** For UL listed installations, this feature must be on.

To turn the setting off or on, do the following:

1. With the display showing UL 98 OPTIONS OFF/ON (current setting), press **1** (off) or **2** (on).
2. The display flashes the entered setting. Press # and the display shows the new setting.

### Global fire (0703)

Default setting is Off.

This setting determines whether or not sirens in all partitions sound (on) if any partition activates a fire alarm.

To turn the setting off or on, do the following:

1. With the display showing GLOBAL FIRE OFF/ON (current setting), press **1** (off) or **2** (on).
2. The display flashes the entered setting. Press # and the display shows the new setting.

### Silent panic (0704)

Default setting is *Off*.

This setting determines whether touchpad police panic alarms are audible (off) or silent (on).

To turn the setting off or on, do the following:

1. With the display showing GLOBAL SILENT PANIC OFF/ON (current setting), press **1** (off) or **2** (on).
2. The display flashes the entered setting. Press # and the display shows the new setting.

## Siren options - Partition 1 setting

The following describes the *Siren option* menu setting that appears under *Partition 1*.

### Silent verify (0710)

Default setting is *Off*.

This setting determines whether the panel supervises the panel speaker terminals (7 and 8). When this feature is on, the panel indicates a trouble condition if no speaker is connected to panel speaker terminals.

**Note:** For UL listed installations, this setting must be on.

To turn the setting off or on, do the following:

1. With the display showing SIREN VERIFY OFF/ON (current setting), press **1** (off) or **2** (on).
2. The display flashes the entered setting. Press # and the display shows the new setting.

## Sensors menu

The *Sensors* menu gives you access to the following settings:

**Learn sensors.** Add (learn) hardwired zones, wireless sensors, and wireless touchpads into panel memory.

**Sensor text.** Name the sensors and zones you have added to the system.

**Delete sensors.** Delete zones and sensors from panel memory.

**Edit sensors.** View or change a sensor group or partition assignment. You can also identify whether a zone is wireless or hardwired, whether it is configured as normally closed (NC) or normally open (NO), and whether the zone is a touchpad.

*Table 10* describes how to trip different types of sensors to program (learn) them in the panel.

*Table 10. Tripping sensors*

Sensor	How to trip the sensor
Hardwired zones	Start with the zone in its "normal" state, then trip the zone into its alarm state. A normally closed door, for example, should be closed when you begin the <i>Learn sensors</i> process. To trip the zone, open the door.
Wireless sensors	Follow the instructions included with each sensor.
Wireless door/window sensors with external contacts	Place the external contact in the alarm condition, then activate the sensor tamper switch.
Self-actuated bell	Activate the tamper switch.
Handheld wireless touchpads	Press the BYPASS button.
Keyfobs	Press and hold the lock and unlock buttons together until the keyfob LED flashes.
ELM keyfobs	Press and release the unlock button twice quickly, then press and hold until the LED flashes three times. Press and release the unlock button once quickly, then press and hold until the LED flashes two times. Press and hold the unlock button until the LED flashes once.

## Learn sensors (080)

Default setting is *None*.

The panel comes with factory programmed onboard hardwired zones. Install 2 kohm, end of line (EOL) resistors on all unused factory sensors programmed on to *Table 10, Tripping sensors* and hardwired zones. If you don't want to install EOL resistors, delete any unused zones from memory. See Table 10 for onboard hardwired zone factory programming. Sensors must be placed in a partition or sensor group. To change the sensor group or partition assignment after adding a sensor or zone, use the *Edit sensors* menu.

To add (learn) sensors into panel memory, do the following:

1. With the display showing `SENSORS`, press `#` and the display shows `LEARN SENSORS`.
2. Press `#` and the display shows `SENSOR PTN 1`.
3. Press `#` to select partition 1 or press `2, 3, 4, 5`, or `6 + #` to select the desired partition. The display should show `SENSOR GROUP 0`.
4. Enter the sensor group + `#`. (See *Table 25* on page 160 for a description of all sensor group characteristics.) The display shows `TRIP SENSOR nn`, where `nn` is the displayed (next available) sensor number.
5. To change the displayed sensor number, enter the desired sensor number + `#`. The desired sensor number is displayed.
6. With the desired sensor number displayed, use the guidelines in *Table 10, Tripping sensors* to force the sensor or zone you are adding (learning) into the panel memory to send a signal to the panel.
7. To add another sensor to the same sensor group and partition, repeat the process.
8. To add sensors to another sensor group or partition, press `*` twice and repeat the process.

*Table 11* describes the factory default zone inputs.

Table 11. Zone factory programming

Zone input	Group number and description
1	10-entry/exit
2	17-instant interior follower
3	13-instant perimeter
4	13-instant perimeter
5	13-instant perimeter
6	13-instant perimeter
7	13-instant perimeter
8	13-instant perimeter

If the panel memory is cleared, all onboard hardwired zone factory programming will be erased.



## Sensor text (081)

Default setting is *None*.

Use the following guidelines to name zone and sensor locations:

- Use the item numbers that appear in *Table 26* on page 164 for characters and words listed there.
- If a desired word does not appear in *Table 26* on page 164 create it using the characters (custom text).
- When using words from *Table 26* on page 164 spaces between them appear automatically. When using characters from the table to create words, you must reserve an item number for a 'space' after the word.
- Each character or word uses one item number. For example, a word from the list counts as one item number.
- Only 16 item numbers are allowed for each zone or sensor name, so plan ahead before programming sensor text. You may need to abbreviate words to avoid running out of item numbers.

To program sensor text, do the following:

1. Press **A** or **B** until the display shows `SENSOR TEXT`.
2. Press **#** and the display shows `TEXT FOR SN 01`.
3. Press **A** or **B** until the display shows the desired sensor number (or enter the desired sensor number and press **#**).
4. Press **#** and the display shows: `SN 1 ITEM 0 0 - _____`. Where *ITEM 0* is the first character/word location and *0* is the character/word number.
5. Enter the number of the character or word, or scroll through the numbers by pressing **B** (forward) or **A** (backward). If you make a mistake, enter the correct number or continue scrolling through choices.
6. Press **#** to accept the displayed choice and the display shows: `SN 1 ITEM 1 0 -`.
7. Repeat the process as needed to complete the zone or sensor name.
8. Press **\*** after entering the last character or word number. The display shows the complete text name. For example: `TEXT FOR SN 01 FRONT ENTRY DOOR`.

## Delete sensors (082)

Default setting is *None*.

**Note:** Deleting sensors does not delete sensor text associated with the deleted sensor number. To delete sensor text, enter the *Sensor text* setting and enter 000 (nulls) for each item number.

To remove hardwired zone and wireless sensor numbers from panel memory, do the following:

1. Press **A** or **B** until the display shows `DELETE SENSORS`.
2. Press **#** and the display shows `DELETE SENSOR nn` (lowest zone/sensor number in panel memory).
3. Press **#** to delete the displayed sensor or, enter the desired sensor number, then press **#**.
4. Repeat the process until all desired sensors are deleted.

## Edit sensors (083)

Default setting is *None*.

This menu lets you view and, if desired, change the group and partition assignment for each learned zone or sensor. For example, the display shows:

```
CODE 1> S01 P1 G13 NC HW BACK DOOR.
```

Where *S01* is the zone/sensor number, *P1* is partition 1, *G13* is sensor group 13, *NC* is normally closed, *HW* is hardwired, and *BACK DOOR* is the programmed text name.

Other description codes include:

- RF (wireless sensor)
- TP (touchpad)
- NO (normally open)

To edit sensors, do the following:

1. Press **A** or **B** until the display shows `EDIT SENSORS`.
2. Press **#** and the display shows the sensor or zone with the lowest number.
3. Press **A** or **B** to scroll through all learned zones and sensors.
4. When the desired zone or sensor is displayed, press **#**. The display shows `SENSOR PTN n` (current partition assignment).
5. Enter the desired partition number, then press **#**. The display shows the new partition assignment.
6. Press **A** or **B** and the display shows `SENSOR GROUP nn` (current group assignment).
7. Enter the desired group number, then press **#**. The display shows the new group assignment.

## Audio verification menu

The *Audio verification* menu lets you set up the audio verification module (AVM) operation in partition 1. If you want audio verification for partitions 2 to 6, you must install a standalone audio verification module and a 4-relay output module (HOM) (60-770) output for that partition.

### Audio verification - partition 1 settings

The following describes the *Audio verification* menu settings that appear under *Partition 1*.

#### Audio verify (09000)

Default setting is *Off*.

This setting determines whether or not the system can be accessed by phone for alarm verification.

To turn the setting off or on, do the following:

1. With the display showing AUDIO VERIFICATION, press #. The display shows PARTITION 1.
2. Press # again and the display shows AUDIO VERIFY OFF/ON (current setting). Press **1** (off) or **2** (on).
3. The display flashes the entered setting. Press # and the display shows the new setting.

#### Audio mode (09001) audio verification-partition (default=1)

This setting determines how the audio verification module operates. Choose one of the following:

**Instant (1).** Allows the central station operator instant access for an audio session by entering the AVM code or by pressing \* (if an AVM access code is not programmed) upon completion of panel alarm report (see [Access timeout \(09004\)](#) on page 90). The panel does not report any alarms during the AVM session except for fire alarms, even if the operator extends the session by pressing any valid key.

**Callback (2).** Allows the central station operator to place a call to the premises within five minutes of the alarm report (panel picks up after one ring). The operator must press \* or enter the AVM access code within 20 seconds after ring. The panel does not report any alarms during the AVM session except for fire alarms, even if the operator extends the session by pressing any valid key.

**Callback silent (3).** Same as *Callback*, except premises phones do not ring.

To set *Audio mode*, do the following:

1. With the display showing AUDIO VERIFY OFF/ON, press **A** or **B** until the display shows AUDIO MODE nn (current setting).
2. Enter the desired mode number (1 to 3).
3. The display flashes the entered setting. Press # and the display shows the new setting.

## Fire shutdown (09002)

Default setting is *Off*.

This setting determines whether system sirens turn off during a fire alarm audio session. To turn the setting off or on, do the following:

1. With the display showing `AUDIO VERIFY OFF/ON`, press **A** or **B** until the display shows `FIRE SHUTDOWN OFF/ON` (current setting).
2. Press **1** (off) or **2** (on). The display flashes the entered setting. Press **#** and the display shows the new setting.

## Silent talkback (09003)

Default setting is *Off*.

This setting determines whether the central station operator can speak to persons on the premises (on) or only listen (off) during a silent or duress alarm audio session. To turn the setting off or on, do the following:

1. With the display showing `AUDIO VERIFY OFF/ON`, press **A** or **B** until the display shows `SILENT TALKBACK OFF/ON` (current setting).
2. Press **1** (off) or **2** (on). The display flashes the entered setting. Press **#** and the display shows the new setting.

## Access timeout (09004)

Default setting is *90 seconds*.

If the *Audio mode* is set to *Instant*, then this setting determines how much time (30 to 300 seconds, in 2-second increments) the central station operator has to enter the AVM access code after the panel is accessed for an audio session.

To change the *Access timeout*, do the following:

1. With the display showing `AUDIO VERIFY OFF/ON`, press **A** or **B** until the display shows `ACCESS TIMEOUT nn SECS` (current setting).
2. Enter the desired time. The display flashes the entered setting. Press **#** and the display shows the new setting.

## Beep delay (09005)

Default setting is *2 seconds*.

This setting determines how long AVM access beeps are delayed (0 to 300 seconds, in 2-second intervals) at the beginning of a 2-way audio session.

To change the *Beep delay*, do the following:

1. With the display showing `AUDIO VERIFY OFF/ON`, press **A** or **B** until the display shows `BEEP DELAY nn SECS` (current setting).
2. Enter the desired time. The display flashes the entered setting. Press **#** and the display shows the new setting.

### Access code (09006)

Default setting is \*\*\*\* or *None*.

This setting determines the code required to access the audio verification module to start an audio session. If no code is programmed, pressing \* starts an audio session.

To change the *Access code*, do the following:

1. With the display showing AUDIO VERIFY OFF/ON, press **A** or **B** until the display shows ACCESS CODE nnnn (current code).
2. Enter the desired four-digit access code. The display flashes the entered code. Press # and the display shows the new setting.

To delete an access code, do the following:

1. With the display showing AUDIO VERIFY OFF/ON, press **A** or **B** until the display shows ACCESS CODE nnnn (current code).
2. Press **D** to delete.

### Vox mic gain (09007)

Default setting is 14.

This setting determines the microphone sensitivity for triggering voice-activated switching (VOX). For the Interrogator 200, the default setting (14) is recommended.

Room size, acoustics, and furnishings where the Interrogator 200 is located will influence the setting. Setting range is from 01 (low) to 64 (high).

To change the vox mic gain, do the following:

1. With the display showing AUDIO VERIFY OFF/ON, press **A** or **B** until the display shows VOX MIC GAIN nn (current setting).
2. Enter the desired two-digit setting (01 to 64). The display flashes the entered setting. Press # and the display shows the new setting.

### Vox gain range (09008)

Default setting is 64.

This setting determines the gain range for voice-activated switching (VOX). Setting range is from 01 (low) to 64 (high). For best results, this setting should be higher than the *Vox mic gain*.

To change the *Vox gain range*, do the following:

1. With the display showing AUDIO VERIFY OFF/ON, press **A** or **B** until the display shows VOX GAIN RANGE nn (current setting).
2. Enter the desired two-digit setting (01 to 64). The display flashes the entered setting. Press # and the display shows the new setting.

### Manual mic gain (09009)

Not used.

### Vox RX gain (09010)

Default setting is *08*.

This setting determines the receiver (talkback) gain level for voice-activated switching (VOX). Setting range is 01 to 10.

If the VOX is switching the speaker on when the central station operator is not talking, lower this setting and the *VOX mic gain* setting.

If the VOX is *not* switching the speaker on when the central station operator is talking, raise this setting and lower the *VOX mic gain* setting.

To change the *Vox RX gain*, do the following:

1. With the display showing AUDIO VERIFY OFF/ON, press **A** or **B** until the display shows VOX RX GAIN nn (current setting).
2. Enter the desired two-digit setting (01 to 10). The display flashes the entered setting. Press # and the display shows the new setting.

## Accessory modules menu

The *Accessory modules* menu gives you access to the following menus:

**Bus devices.** This menu lets you read bus device unit numbers, assign bus devices to a partition, and configure other features associated with a specific bus device.

**SnapCards.** This menu lets you set the configuration number for each SnapCard output, assign SnapCard outputs to a partition, and name the SnapCard outputs.

### Accessory modules - bus device settings

The following describes how to program the *Accessory modules* menu settings that appear under *Bus devices*.

**Note:** Most settings under *Accessory modules - bus devices* have no shortcut numbers.

#### Unit-ID (10000 to 10015)

Default setting is \*\*\*\* or *None*.

This menu lets you identify all connected bus devices, view each unit number, view the device ID number, and configure other settings based on a specific device. This menu also lets you delete learned bus devices.

To help identify bus devices, the 8-digit device ID number is also located on a label on each SuperBus 2000 device.

To identify bus device unit and ID, do the following:

1. With the display showing `BUS DEVICES`, press `#`. The display shows the bus unit number and the 8-digit device ID number. For example: `UNIT - ID 0-02110185`. Where `0` is the unit number and `02110185` is the device ID number.
2. Press **A** or **B** to identify all other bus unit numbers (0 to 15) and device ID numbers.

To delete learned unit numbers, do the following:

1. With the display showing `BUS DEVICES`, press `#`. The display shows the bus device set to unit number 0.
2. Press **A** or **B** until the bus device unit number you want to delete is displayed.
3. Press **D**. The display changes the unit number to *None*.

#### Device ID

Default setting is *None*.

This menu lets you change the bus device ID number when replacing a defective bus device. To change a device ID, do the following:

1. With the display showing the desired bus device, press `# + #`. The display shows `DEVICE ID` (current ID).
2. Enter the ID of the new bus device. The display flashes the entered selection. Press `#` and the display shows the new setting.
3. Exit programming mode.

4. Remove AC and battery power from the panel.
5. Replace the defective bus device with a new one.
6. Apply AC and battery power to the panel.

## Partition assign

This menu lets you assign bus devices to work in the desired partition.

**Note:** SuperBus 2000 8Z input modules, SuperBus 2000 4-relay output modules, and SuperBus 2000 RF receivers are not assigned to partitions.

To assign bus devices to partitions, do the following:

1. With the display showing the desired bus device, press #.
2. Press **A** or **B** until the display shows `DEVICE PTN` and then press #. The display shows `PARTITION ASSIGN n`.
3. Press **1** to **6** to select the desired partition. The display flashes the entered selection. Press # and the display shows the new setting.

## Output programming

Use these settings to program the output points of any installed SuperBus 2000 hardwire output module. The installer programs a HOM output point into the Concord security panel by entering three kinds of information.

**Partition.** The system partition (1 to 6).

**Trigger.** The event that activates the output point. Trigger events can be partition alarms, trouble conditions, open sensors, etc. (see *Appendix C, Reference tables*).

**Response.** How the output responds to a trigger event.

Only the onboard and SnapCard outputs can be configured for user control.

To program each of the HOM output point configurations into the security panel, do the following:

1. With the display showing the desired bus device, press #.
2. Press **A** or **B** until the display shows `OUTPUTS`.
3. Press #. The display shows `OUTPUT 1`.
4. Press **A** or **B** to select an output, then press #. The display shows `PARTITION ASSIGN 1`.
5. Press **1** to **6** to select the desired partition assignment for this relay. The display flashes the entered setting. Press # and the display shows the new setting.
6. Press **A** or **B**. The display shows `CONFIGURATION ttrr` (current setting). The point configuration number is *ttrr*; where *ttt* is the trigger number and *rr* is the response number.
7. Enter the desired five-digit configuration number for this relay. The display flashes the entered setting. Press # and the display shows the new setting.
8. Press # and repeat the process until all outputs are programmed.



## Status beeps

Default setting is *On*.

This setting determines whether or not the selected touchpad sounds status beeps. Each touchpad can be set individually. This feature is usually turned off for a touchpad that is located in or near bedrooms, to avoid disturbing sleeping persons.

**Note:** For UL listed installations, *Status beeps* must be on.

To turn touchpad status beeps on or off, do the following:

1. With the display showing the desired touchpad, press # then **A** or **B** until the display shows `KEYPAD OPTIONS`.
2. Press # and the display shows `STATUS BEEPS OFF/ON` (current setting).
3. Press **1** (off) or **2** (on) to select the desired setting. The display flashes the entered selection. Press # and the display shows the new setting.

## Key beeps

Default setting is *On*.

This setting determines whether or not selected touchpads beep when their buttons are pressed. This feature is usually turned off for a touchpad that is located in or near bedrooms, to avoid disturbing sleeping persons.

To turn key beeps on or off, do the following:

1. With the display showing the desired touchpad, press # then **A** or **B** until the display shows `KEYPAD OPTIONS`. Next, press # then **A** or **B** until the display shows `KEY BEEPS OFF/ON` (current setting).
2. Press **1** (off) or **2** (on) to select the desired setting. The display flashes the entered selection. Press # and the display shows the new setting.

## Freeze temps

Default setting is *42°F*.

This setting determines the temperature point that the energy saver module detects a potential freeze (heating failure) condition. The adjustable range is from 40 to 90°F.

**Note:** This is the same menu found under [Reporting - partition 1 to 6 settings](#) on page 78. The setting is used by both the SuperBus 2000 energy saver module and dialog RF thermostat. Individual freeze temperature settings for each device are not allowed.

To change the freeze temp setting, do the following:

1. With the display showing the desired bus device press #, then **A** or **B** until the display shows `ENERGY OPTIONS`. Next, press # then **A** or **B** until the display shows `FREEZE TEMP nn DEGREES` (current setting).
2. Enter the desired freeze temperature (40 to 90°F). The display flashes the entered selection. Press # and the display shows the new setting.

## Temperatures

Default setting is *None*.

This setting lets you adjust the energy saver module (ESM) room temperature setting to match the premises thermostat. The adjustable range is from 40 to 90°F.

**Note:** To ensure accuracy, wait at least 15 minutes before setting the ESM temperature to allow the ESM to warm or cool to actual room temperature.

To change the ESM temperature setting, do the following:

1. With the display showing the desired bus device press #, then **A** or **B** until the display shows ENERGY OPTIONS. Next, press # and then **A** or **B** until the display shows TEMPERATURE nn DEGREES (current setting).
2. Enter the desired temperature (40 to 90°F). The display flashes the entered selection. Press # and the display shows the new setting.

## Cellular system

Default setting is *B*.

This setting determines the cellular transmission system (A or B) used for cellular communication. This information is provided by the cellular provider based on installation zip code.

To set the cellular system, do the following:

1. With the display showing the desired bus device press **1**, (**B**) or **2** (**A**). The display flashes the entered selection.
2. Press # and the display shows the new setting.

## Accessory modules - SnapCard settings

The following describes how to program the *Accessory module* menu settings that appear under *SnapCards*.

### Output programming

This setting lets you assign a partition and a five-digit configuration number for each SnapCard relay output. This number determines both which system event activates the output and the duration or time the output is activated. To program the settings, do the following:

1. Assign the partition (1 to 6).
2. Assign the configuration number (combination of a trigger number and a response number).

**Trigger.** The event that activates the output point. Trigger events can be partition alarms, trouble conditions, open sensors, etc. (see *Appendix B, Settings*).

**Response.** How the output responds when trigger event occurs (see *Appendix B, Settings*).

To assign configuration numbers to SnapCard relay outputs, do the following:

1. With the display showing SNAPCARDS, press #. Then press **A** or **B** until the display shows OUTPUT PROGRAMMING.

2. Press # again and the display shows OUTPUT 1 .
3. Press **A** or **B** to select the desired output (**1** to **4**), then press #.
4. With the display showing PARTITION ASSIGN 1, press **1** to **6** to select the desired partition. Press # to confirm the partition.
5. Press **A** or **B** until the display shows CONFIGURATION ttrr (current setting).
6. Enter the desired five-digit configuration number for this relay. Press # to confirm the setting.
7. Press # and repeat the process until all outputs are programmed.

## Output text (10120 to 10123)

Default setting is *None*.

Entering text for an output allows the user to control it directly or by schedule. Use the following guidelines to name SnapCard outputs:

- Use the item numbers that appear in *Appendix C, Reference tables* for characters and words listed there.
- If you want an output for User Output Control, you must use the output text feature to name the output. If no output text is programmed, the user will not have access to the output.
- When using words from *Appendix C, Reference tables*, spaces between them appear automatically. When using characters from the table to create words, you must reserve an item number for a *space* after the word.
- Each character or word uses one item number. For example, a word from the list counts as one item number.
- Only 16 item numbers are allowed for each output name, so plan ahead before programming output text. You may need to abbreviate words to avoid running out of item numbers.

To program output text, do the following:

1. With the display showing `SNAPCARDS`, press **#**, then **A** or **B** until the display shows `OUTPUT TEXT`.
2. Press **#** and the display shows `OUTPUT 1`.
3. Press **A** or **B** until the desired output number is displayed.
4. Press **#** and the display shows `OUTPUT N ITEM 0 0 -` where *ITEM 0* is the first character/word location and *0* is the character/word number.
5. Enter the number of the desired character or word, or scroll through the numbers by pressing **B** (forward) or **A** (backward). If you make a mistake, enter the correct number or continue scrolling through choices.
6. Press **#** to accept the displayed choice and the display shows `OUTPUT N ITEM 1 0 -`.
7. Repeat the process as needed to complete the output name.
8. Press **\*** after entering the last character or word number. The display shows the complete text name. For example: `OUTPUT 1 GARAGE DOOR`.

## Onboard options menu

The *Onboard options* menu lets you set up the following built-in options:

**Inputs.** This menu lets you turn the *smoke verification* and the *two-wire smoke* features off or on. (See [Onboard options - inputs settings](#).)

**Output programming.** This menu lets you set configuration numbers for the two built-in panel outputs and assign the outputs to partitions. (See [Onboard options - output programming settings](#) on page 100.)

**Output text.** This menu lets you assign text to the two built-in outputs so they can be controlled by the user. (See [Onboard options - output text settings](#) on page 101.)

### Onboard options - inputs settings

The following section describes the *Onboard options* menu settings that appear under *Inputs*.

#### Two-wire smoke (1101)

Default setting is *Off*.

This setting determines how onboard hardwired zone 8 is configured. When this setting is on, zone 8 will be configured for two-wire smoke detectors. When off, it will be configured for a normal hardwire input.

To turn the setting off or on, do the following:

1. With the display showing `ONBOARD OPTIONS`, press `#` twice. The display shows `SMOKE VERIFY OFF/ON` (current setting).
2. Press `A` or `B` until the display shows `TWO-WIRE SMOKE ON/OFF` (current setting).
3. Press `1` (off) or `2` (on). The display flashes the entered number. Press `#` and the display shows the new setting.

## Onboard options - output programming settings

The following section describe the *Onboard options* menu settings that appear under *Output programming*.

### Output 1, 2

Shortcuts are: Output 1 partition assignment (11100), configuration (11101); Output 2 partition assignment (11110), configuration (11111).

Default setting is *Ptn 1, 01614* for Output 1 and *Ptn 1, 01710* for Output 2.

This setting assigns the partition and the five-digit configuration number for the two onboard outputs. The configuration number determines

- Which system event activates the selected output.
- The duration or time the output is activated.

The first three digits represent the trigger number of an event (such as triggering an alarm, opening a sensor, or arming the system). The last two digits represent how the output responds, For example, momentary switching, maintained (or latched) switching, or switching for a preset time.

**Note:** If you want to configure an output for user *Output control* you must use the *Output text* feature to name the output. If no output text is programmed, user *Output control* will not function for that output.

Use the system event trigger and response numbers listed in. See *Appendix C, Reference tables*.

To set up onboard Output 1 and 2 partition and configuration assignments, do the following:

1. With the display showing `ONBOARD OPTIONS`, press `# + B`. The display shows `OUTPUT PROGRAMMING`.
2. Press `#` and the display shows `OUTPUT 1`. Press `B` to select `OUTPUT 2`.
3. Press `#` and the display shows `PARTITION ASSIGN n` (current setting).
4. Press 1 to 6 to assign the output to the desired partition, then press `#`. The display shows `PARTITION ASSIGN (new setting)`.
5. Press `B` and the display shows `CONFIGURATION ttttrr` (current setting).
6. Enter the configuration number. The display flashes the entered number. Press `#` and the display shows the new setting.
7. Press `#` and repeat the process until all outputs are programmed.

## Onboard options - output text settings

The following section describe the *Onboard options* menu settings that appear under *Output text*.

### Output text (1120 to 1121)

Default setting is *None*.

Entering text for an output allows you to control it directly or by schedule. Use the following guidelines to name onboard outputs:

- Use the item numbers listed in *Appendix C, Reference tables* for characters and words.
- If you want to configure an output for user output control you must use the output text feature to name the output. If no output text is programmed, output control will not function for that output.
- If a desired word does not appear in *Appendix C, Reference tables*, create it using the characters (custom text).
- When using words from *Appendix C, Reference tables* spaces between them appear automatically. When using characters from the table to create words, you must reserve an item number for a space after the word.
- Each character or word uses up one item number. For example, a word from the list counts as one item number.
- Only 16 item numbers are allowed for each output name, so plan ahead before programming output text. You may need to abbreviate words to avoid running out of item numbers.

To program output text, do the following:

1. With the display showing `ONBOARD OPTIONS`, press `#` then press **B** twice and the display shows `OUTPUT TEXT`.
2. Press `#` and the display shows `OUTPUT 1`.
3. Press `#` and the display shows: `OUTPUT 1 ITEM 0 0 -`. Where *ITEM 0* is the first character or word location and *0* is the character or word number.
4. Enter the number of the character or word, or scroll through the numbers by pressing **B** (forward) or **A** (backward). If you make a mistake, enter the correct number or continue scrolling through choices.
5. Press `#` to accept the displayed choice and the display shows `OUTPUT 1 ITEM 1 0 -`.
6. Repeat the process as needed to complete the output name.
7. Press `*` after entering the last character or word number. The display shows the complete text name. For example, `OUTPUT 1 GARAGE DOOR`.

## Macro keys menu

The *Macro keys* menu lets you set up single-button system commands with the ATP2100 and ATP2600 touchpads.

### Macro keys - partition 1 to 6 settings

The following describes how to program the *Macro keys* menu settings that appear under *Partition 1 to 6*.

#### Macro keys

Default setting is *Chime 71* for Macro Key 1, *Stay 2* for Macro Key 2, *Quick exit D* for Macro Key 3, *Away 3* for Macro Key 4.

This menu lets you program the Chime, Stay, Exit, and Away macro keys on ATP2100 and ATP2600 touchpads. Macro keys let you perform a system command with one button, eliminating manual entry of the command. For example, the **Stay** key can be programmed so that it automatically arms the system to level 2 with *No delay* just by pressing it once.

- Each partition can accept up to four macros.
- All touchpads in a partition use the same set of macros.
- Macro keys can execute a system command up to 14 keypresses in length. Use keys **0** to **9**, **#**, **\***, and **A** to **F** to program macros.
- Panic keys, long keypresses (press and hold), and macro keys themselves cannot be used in a macro.
- When programming a macro to enter user programming, you must enter two delays (F key) after the access code - and before any shortcut number. For example, the macro key sequence for entering the *Set time* menu would be *9CODEFF020*.
- When using an ATP2100 or ATP2600 to jump to another partition, pressing the macro buttons on the jumped touchpad will execute macro commands based on the macros programmed in the jumped partition.

**Note:** We recommend that you do not program macros that disarm the system.

To program/change a macro key, do the following:

1. With the display showing `MACRO KEYS`, press **#**. The display shows `PARTITION 1`.
2. Press **A** or **B** to select the desired partition (1 to 6), then press **#**. The display shows `MACRO KEY 1` (current setting).
3. Press **A** or **B** to select the desired macro key you want to program (1 to 4).
4. To change this macro, press the associated macro key. The current setting disappears and is replaced with a flashing cursor.
5. Enter the desired system command. The display flashes the entry.  
**Note:** If you make a mistake, press the macro key twice to clear the entry and start over.
6. Press the macro key again to accept the entered command. The display stops flashing.



## Quick programming mode

Use the quick programming mode to program basic system programming with a SuperBus 2000 fixed display touchpad, SuperBus 2000 FTP 1000 touchpad, or any SuperBus 2000 alphanumeric touchpad. The following menus are accessible:

- Account number (all partitions)
- CS phone 1
- CS phone 2
- CS phone 3
- Learn sensors—limited to selecting sensor number, sensor group, and partition assignment. An alphanumeric touchpad is required for programming sensor text in standard programming mode.

Use *A* and *B* buttons to toggle across main menus and use the # and \* buttons to toggle up and down through submenus.

To enter quick programming mode, do the following:

1. Make sure the system is disarmed in all partitions.
2. Press **8** + *installer/dealer code* + **03**. The display shows *ACCOUNT NUMBER*.
3. Cycle through the menus as shown in *Table 12*.

Table 12. Quick programming

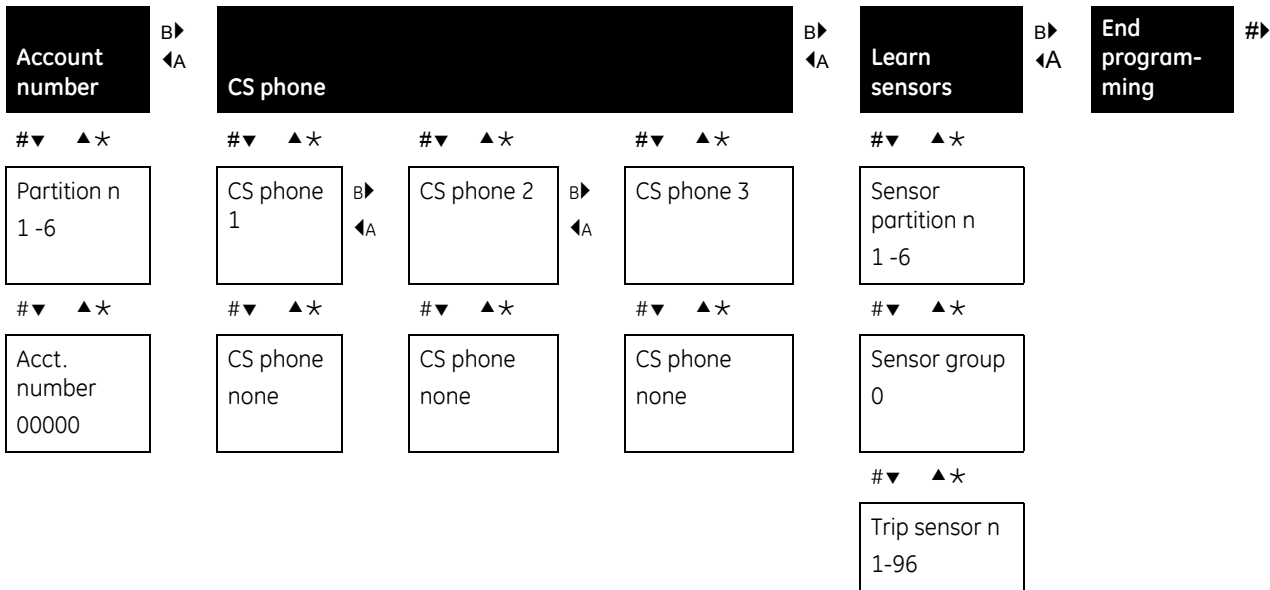

## User programming mode

Use user programming mode to view system version information and program the following system settings:

- *Time and date menu* on page 104.
- *User codes menu* on page 105.
- *Options menu* on page 108.
- *Set up schedules menu* on page 110.
- *Attach schedules to events menu* on page 111.
- *Energy saver menu* on page 114.
- *Attach lights to sensors menu* on page 115.
- *System version menu* on page 115.

You can enter user programming from an alphanumeric or fixed display touchpad by using the system or partition master code. The default system master code is *1234*.

To enter user programming mode, press **9** + **CODE**. The display shows `TIME AND DATE`.

### Time and date menu

The panel uses a global clock and calendar for time and date. Alphanumeric touchpads display the panel time and date whenever the system is disarmed.

**Note:** Setting the time and date is important for accurate tracking of system events stored in the event buffer.

The *Time and date* menu lets you set this clock and calendar.

#### Time (020)

Default setting is *00:00*.

This setting lets you adjust the panel clock to the correct time. The panel uses a 24-hour clock. For example, to set the time to 4:17 p.m., enter 1617. To set the time, do the following:

1. With the display showing `TIME AND DATE` press **#** and the display shows `TIME hh:mm` (current time).
2. Enter the correct time (0000 to 2359). The display flashes the entered time. Press **#** and the display shows the new time.

#### Date (021)

Default setting is *01/01/00*.

This setting lets you adjust the panel calendar to the correct month, day, and year. To set the date, do the following:

1. With the display showing `TIME AND DATE`, press **#**, then **A** or **B** until the display shows `DATE nn/nn/nn` (current date).
2. Enter the correct month (01 to 12), day (01 to 31), and year (00 to 99). For example, enter 090107 for September 1, 2007. The display flashes the entered date. Press **#** and the display shows the new date.

## User codes menu

The *User codes* menu lets you program/change regular user access codes, partition master codes, and the system master code. You can enter up to 230 separate user codes, allowing up to 230 different users access to the security system. You can also specify whether or not a specific user is able to perform specific actions, like bypassing sensors or testing the system.

### User nnn (030nnn0 where nnn is user number 000 to 229)

Default setting is *None*.

User codes provide basic arming and disarming functions. The system allows up to 230 user codes (user numbers 000 to 229). User numbers that show **\*\*\*\*** indicate no code is currently programmed for that user number.

To program regular user codes, do the following:

1. With the display showing `USER CODES`, press **#** and the display shows `REGULAR USER CODES .`
2. Press **#** and the display shows `USER nnn` (first available user number).
3. Press **A** or **B** to select the desired user number, then press **#**. The display shows `USER nnn - nnnn`.
4. With the user number displayed, enter a four-digit user code. The display flashes the entered code. Press **#** and the display shows `USER nnn - nnnn` (new code).

To delete regular user codes, do the following:

1. With the display showing `USER CODES`, press **#** and the display shows `REGULAR USER CODES .`
2. Press **#** and the display shows `USER nnn - nnnn` (first available user number).
3. Press **A** or **B** to select the user number/user code you want to delete (if it is not already displayed), then press **#**. The display shows `USER nnn - nnnn`.
4. Enter the system or partition master code. The display flashes the entered code. Press **#** and the display shows `USER nnn -- ****` (no code).

### Direct bypassing (030nnn1 where nnn is user number 00 to 229)

Default setting is *Off*.

This setting determines whether a specific user code provides access to the *Bypass sensors* feature. Set this feature to on for all users who need to be able to bypass sensors.

To turn the setting off or on, do the following:

1. With the display showing `USER CODES`, press **#** and the display shows `REGULAR USER CODES`.
2. Press **#** and the display shows `USER nnn` (first available user number).
3. Press **A** or **B** to select the desired user number, then press **#**. The display shows `USER nnn - nnnn`.
4. Press **A** or **B** until the display shows `DIRECT BYPASSING OFF/ON` (current setting).
5. Press **1** (off) or **2** (on). The display flashes the entered setting. Press **#** and the display shows the new setting.

### Remote access (030nnn2 where nnn is user number 000 to 229)

Default setting is *Off*.

This setting determines whether the user can access the panel from a remote phone (a phone located off the premises).

To turn the setting off or on, do the following:

1. With the display showing `USER CODES`, press `#` and the display shows `REGULAR USER CODES`.
2. Press `#` and the display shows `USER nn` (first available user number).
3. Press **A** or **B** to select the user number, then press `#`. The display shows `USER nnn - nnnn`.
4. Press **B** until the display shows `REMOTE ACCESS ON/OFF` (current setting).
5. Press **1** (off) or **2** (on). The display flashes the entered setting. Press `#` and the display shows the new setting.

### System tests (030nnn3 where nnn is user number 000 to 229)

Default setting is *Off*.

This setting determines whether a specific user code provides access to the phone and sensor tests. Set this feature to on for all users who need to be able to conduct phone and sensor tests.

To turn the setting off or on, do the following:

1. With the display showing `USER CODES`, press `#` and the display shows `REGULAR USER CODES`.
2. Press `#` and the display shows `USER nn` (first available user number).
3. Press **A** or **B** to select the user number, then press `#`. The display shows `USER nnn - nnnn`.
4. Press **A** or **B** until the display shows `SYSTEM TESTS OFF/ON` (current setting).
5. Press **1** (off) or **2** (on). The display flashes the entered setting. Press `#` and the display shows the new setting.

### Latchkey report (030nnn4 where nnn is user number 000 to 229)

Defaults setting is *On* for 000 to 005, and *Off* for 006 to 229.

This setting determines whether the user code causes a latchkey report to be sent to a pager when the code is used to change arming levels.

To assign the latchkey report attribute to user codes, do the following:

1. With the display showing `USER CODES`, press `#` and the display shows `REGULAR USER CODES`.
2. Press `#` and the display shows `USER nn` (first available user number).
3. Press **A** or **B** to select the user number, then press `#`. The display shows `USER nnn - nnnn`.
4. Press **A** or **B** until the display shows `LATCHKEY OFF/ON` (current setting).
5. Press **1** (off) or **2** (on). The display flashes the entered setting. Press `#` and the display shows the new setting.

## Partition assign (030nnn5 where nnn = user number 000 to 229)

Default setting is *Ptn 1*.

This setting determines which partitions a user code can access. A code can be assigned to all partitions if desired, making it usable at any touchpad in any partition and able to jump to any selected partition.

To assign partitions to a user code, do the following:

1. With the display showing `USER CODES`, press `#` and the display shows `REGULAR USER CODES`.
2. Press `#` and the display shows `USER nn` (first available user number).
3. Press **A** or **B** to select the user number, then press `#`. The display shows `USER nnn - nnnn`.
4. Press **A** or **B** until the display shows `PARTITION ASSIGN` (current setting).
5. Enter the desired partitions (1 to 6). The display flashes the entered numbers. Press `#` and the numbers stop flashing.

## Partition master (0310 to 0315)

Default setting is *None*.

The partition master code provides access to all system operations and user programming *for a single partition*. You must be in the partition of the partition master code you wish to change.

To change the partition master code, do the following:

1. With the display showing `USER CODES`, press `#` then **A** or **B** until the display shows `PARTITION MASTER CODE`.
2. Press `#` and the display shows `PARTITION nnnn` (current code).
3. Enter a new four-digit code. The display flashes the entered code. Press `#` and the display shows the new code.

## System master (0320)

Default setting is *1234*.

The system master code provides access to all system operations and user programming.

**Note:** In the partition where the indicating power device is located, only the system master code may be enabled to disarm that partition.

To change the system master code, do the following:

1. With the display showing `USER CODES`, press `#` then **A** or **B** until the display shows `SYSTEM MASTER CODE`.
2. Press `#` and the display shows `SYSTEM MASTER nnnn` (current code).
3. Enter a new four-digit code. The display flashes the entered code. Press `#` and display shows the new code.

## Options menu

The *Options* menu lets you set up the system for downloading and silent arming. You can also adjust alphanumeric touchpad display brightness from this menu

### Downloading (041)

Default setting is *On*.

When this setting is on, the panel can communicate with Enterprise Downloader software for programming the system from offsite.

**Note:** For this feature to work, the panel must be connected to a phone line and be programmed with *Remote access* on, with a Downloader phone number, and with a Downloader code.

To turn the setting off or on, do the following:

1. Press **A** or **B** until the display shows `OPTIONS`. Press **#**, then **A** or **B** until the display shows `DOWNLOADING OFF/ON` (current setting).
2. Press **1** (off) or **2** (on). The display flashes the entered selection. Press **#** and the display shows the new setting.

### Touchpad brightness (043)

Default setting is 2.

This setting lets the user lighten or darken the background on touchpad displays. Each touchpad can be set to compensate for lighting conditions in the touchpad location.

To adjust touchpad brightness, do the following:

1. Press **A** or **B** until the display shows `OPTIONS`.
2. Press **#**, then **A** or **B** until the display shows `TOUCHPAD BRIGHTNESS n` (current setting).
3. Enter a setting from **0** (darkest background) to **3** (brightest background). The display flashes the entered selection. Press **#** and the display shows the new setting.

### Volume (044)

Default setting is 4.

This setting determines the volume level of status sounds from speakers connected to the phone interface/voice module or voice only module (VOM).

**Note:** This menu appears only if a phone interface/voice module or a VOM is connected to the panel.

To adjust status sound volume, do the following:

1. Press **A** or **B** until the display shows `OPTIONS`, then press **#**.
2. Press **A** or **B** until the display shows `VOLUME n` (current setting).
3. Enter a setting from **0** (off) to **7** (loudest). The display flashes the entered selection. Press **#** and the display shows the new setting.

## Voice chime (045)

Default setting is *On*.

This setting determines whether speakers connected to the phone interface/voice module or voice-only module announce perimeter sensor/zone numbers that are tripped when the chime feature is on. This menu appears only if a phone interface/voice module or a VOM is connected to the panel.

To turn voice chime off or on, do the following

1. Press **A** or **B** until the display shows `OPTIONS`.
2. Press **#** then **A** or **B** until the display shows `VOICE CHIME OFF/ON` (current setting).
3. Press **1** (off) or **2** (on). The display flashes the entered selection. Press **#** and the display shows the new setting.

## Chime on close (046)

Default setting is *Off*.

When this setting is on, the panel sounds a single chime when a perimeter door or window is closed.

To turn chime on close off or on, do the following:

1. Press **A** or **B** until the display shows `OPTIONS`.
2. Press **#** then **A** or **B** until the display shows `CHIME ON CLOSE OFF/ON` (current setting).
3. Press **1** (off) or **2** (on). The display flashes the entered selection. Press **#** and the display shows the new setting.

## Set up schedules menu

The *Set up schedules* menu lets you set up timeframes for light control, output control, automatic arming, latchkey times, and exception opening/closing reports. The system (all partitions) allows you to set up to 16 schedules (00 to 15) which are shared by all partitions.

Setting up schedules consists of setting a start and stop time for each schedule, then selecting which days of the week the schedule will be active. You can also set up a *rollover* schedule, which starts on one day and ends on another day. This saves programming time and leaves more schedules available (in case they are needed later).

For example, to set up a schedule to rollover from Tuesday evening to Wednesday morning, set a schedule start time for 2200 (10:00 p.m.) and a stop time for 0500 (5:00 a.m.). Set the schedule to turn on Tuesday. Because the stop time is set for morning, the system automatically carries the schedule over to the next day.

If you use the same start and stop times described above and set the schedule to turn on Monday through Friday, then one schedule will cover the entire week.

## Set up schedules (05XXY, where XX is schedule 00 to 15 and Y is start [0]/stop[1] Monday to Sunday [2 to 8])

Default setting is *00:00*.

This menu lets you set up start/stop times for each day of the week. Schedules used by one partition cannot be viewed or changed from a different partition.

**Note:** If you are programming schedules for your customer, be sure to record the settings in the *Concord 4 User Manual*.

To set up a time schedule, do the following:

1. Press **A** or **B** until the display shows SET UP SCHEDULES.
2. Press **#** and the display shows SCHEDULE 00. If you want a different schedule number, press **A** or **B** until the schedule number appears.
3. Press **#** and the display shows START TIME hh:mm (current setting).
4. Enter the starting time (00:00 to 23:59). The display flashes the entered time. Press **#** and the display shows START TIME hh:mm (new setting).
5. Press **B** and the display shows STOP TIME hh:mm (current setting).
6. Enter the desired stop time (00:00 to 23:59). The display flashes the entered time. Press **#** and the display shows STOP TIME hh:mm (new setting).
7. Press **B** and the display shows MONDAY OFF/ON (current setting). To select a different day, continue pressing **B** until the desired day appears.
8. Press **1** (off) or **2** (on). The display flashes the entered selection. Press **#** and the display shows the new setting for the selected day.
9. Repeat the process until all desired settings for each day are set.

## Attached schedules to events menu

The *Attach schedules to events* menu lets you link the following system events to time schedules:

- Latchkey opening.** Sends a report if system is disarmed within the attached time schedule.
- Latchkey closing.** Sends a report if system is armed within the attached time schedule.
- Exception opening.** Sends a report if system is not disarmed within the attached time schedule.
- Exception closing.** Sends a report if system is not armed within the attached time schedule.
- Lights (1 to 9).** Activate X10 controlled lights by the attached time schedule.
- Outputs (1 to 6).** Allow users to attach onboard (1–2) and SnapCard outputs to a schedule.
- Arming.** Allows the user to arm the panel at the schedule start time.

### Latchkey reports (opening: 060nn, closing: 061nn, where nn is schedule number)

Default setting is *Off*.

This setting lets you attach the latchkey opening report feature and the latchkey closing report feature to time schedules. To attach a schedule to latchkey opening or latchkey closing, do the following:

1. Press **A** or **B** until the display shows ATTACH SCHEDULES TO EVENTS.
2. Press **#** then **A** or **B** until the display shows LATCHKEY OPENING or LATCHKEY CLOSING.
3. Press **#** and the display shows SCHEDULE 00 OFF/ON (current setting). If you want a different schedule, press **A** or **B** until the desired schedule appears.



4. Press **1** (off) or **2** (on). The display flashes the entered selection. Press **#** and the display shows the new setting for the selected schedule.

### Exception reports (opening: 062nn, closing: 063nn, where nn is schedule number)

This setting lets you attach the exception opening report feature and the exception closing report feature to time schedules. To attach a schedule to exception opening or exception closing, do the following:

1. Press **A** or **B** until the display shows ATTACH SCHEDULES TO EVENTS.
2. Press **#** then **A** or **B** until the display shows EXCEPTION OPENING OR EXCEPTION CLOSING.
3. Press **#** and the display shows SCHEDULE 00 OFF/ON (current setting). If you want a different schedule, press **A** or **B** until the schedule appears.
4. Press **1** (off) or **2** (on). The display flashes the entered selection. Press **#** and the display shows the new setting for the selected schedule.

### Exception reports (opening: 062nn, closing: 063nn, where nn is schedule number)

Default setting is *Off*.

This setting lets you attach the exception opening report feature and the exception closing report feature to time schedules. To attach a schedule to exception opening or exception closing, do the following:

1. Press **A** or **B** until the display shows ATTACH SCHEDULES TO EVENTS.
2. Press **#** then **A** or **B** until the display shows EXCEPTION OPENING OR EXCEPTION CLOSING.
3. Press **#** and the display shows SCHEDULE 00 OFF/ON (current setting). If you want a different schedule, press **A** or **B** until the schedule appears.
4. Press **1** (off) or **2** (on). The display flashes the entered selection. Press **#** and the display shows the new setting for the selected schedule.

### Lights (064xnn where nn is schedule number and x is light number minus 1)

Default setting is *Off*.

This setting lets you attach light controls to a time schedule. To attach schedules to lights, do the following:

1. Press **A** or **B** until the display shows ATTACH SCHEDULES TO EVENTS.
2. Press **#** then **A** or **B** until the display shows LIGHTS. Press **#** to enter the *Lights* menu.
3. Press **A** or **B** until the light appears.
4. Press **#** and the display shows SCHEDULE 00 OFF/ON (current setting). If you want a different schedule, press **A** or **B** until the desired schedule appears.
5. Press **1** (off) or **2** (on). The display flashes the entered selection. Press **#** and the display shows the new setting for the selected schedule.
6. Repeat the process until all desired lights are attached to schedules.

## Outputs (065xnn where nn is schedule number and x is output number minus 1)

Default setting is *Off*.

This setting lets you attach outputs to a time schedule. Onboard outputs are 1 to 2, SnapCard outputs are 3 to 6.

**Note:** Only onboard and SnapCard outputs can be scheduled. These outputs can only be scheduled if output text has been entered in installer programming and if the output is assigned to the same partition as the touchpad used.

To attach schedules to outputs, do the following:

1. Press **A** or **B** until the display shows ATTACH SCHEDULES TO EVENTS.
2. Press # then **A** or **B** until the display shows OUTPUTS. Press # to enter the *Outputs* menu.
3. Press **A** or **B** until the output appears.
4. Press # and the display shows SCHEDULE 00 OFF/ON (current setting). If you want a different schedule, press **A** or **B** until the schedule appears.
5. Press **1** (off) or **2** (on). The display flashes the entered selection. Press # and the display shows the new setting for the selected schedule. Repeat the process until all desired outputs are attached to schedules.

## Arming (0660nn where nn is schedule number)

Default setting is *Off*.

This setting lets you arm according to a time schedule.

**Note:** This setting will allow you to arm to *Away* only. There is no disarm schedule.

To attach schedules to arming, do the following:

1. Press **A** or **B** until the display shows ATTACH SCHEDULES TO EVENTS.
2. Press # then **A** or **B** until the display shows ARMING.
3. To select arm to *Away* press #.
4. Press # and the display shows SCHEDULE 00 OFF/ON (current setting). If you want a different schedule, press **A** or **B** until the schedule appears.
5. Press **1** (off) or **2** (on). The display flashes the entered selection. Press # and the display shows the new setting for the selected schedule.
6. Repeat the process until all desired schedules are attached.

## Energy saver menu

The *Energy saver* menu lets you set the energy saver module or dialog RF thermostat low- and high-setpoints. These setpoints override the premises thermostat allowing the energy saver module or dialog RF thermostat to activate the furnace/air conditioner.

### Low setpoint (070)

Default setting is 50°F.

This setting determines the temperature at which the energy saver module relay closes to activate the furnace.

**Note:** The low setpoint cannot be set equal to or higher than the high setpoint.

To set the low setpoint, do the following:

1. With the display showing *Energy Saver*, press #, then **A** or **B** until the display shows `LOW SETPOINT NN DEGREES (current setting)`.
2. Enter the desired temperature (45 to 89°F). The display flashes the entered setting. Press # and the display shows the new setting.

## High setpoint (071)

Default setting is 90°F.

This setting determines the temperature at which the energy saver module relay closes to activate the air-conditioner.

**Note:** The high setpoint cannot be set equal to or lower than the low setpoint.

To set the high setpoint, do the following:

1. With the display showing `ENERGY SAVER`, press #, then **A** or **B** until the display shows `HIGH SETPOINT nn DEGREES (current setting)`.
2. Enter the desired temperature (46 to 90°F). The display flashes the entered setting. Press # and the display shows the new setting.

## Attach lights to sensors menu

The *Attach lights to sensors* menu lets you assign a light number to a sensor. Each time the sensor is activated, the attached light will turn on for 5 minutes. When the 5-minute timer expires the light will turn off. If the same light is scheduled, it will only turn on during the schedule time.

### Light X to Sensor Y (08n where n is light number minus 1)

Default setting is 0.

This menu attaches light *x* to sensor *y*. Each time a selected sensor is tripped, the selected light will turn on and a 5-minute timer will start. The sensor must be learned into the current partition before it can be attached

To attach a light to a sensor, do the following:

1. With the display showing `LIGHT 1 TO SENSOR y (current setting)`, press **A** or **B** to select the light number.
2. Enter the sensor number (01 to 96). The display flashes the entered setting. Press # and the display shows the new setting.
3. Repeat the process until all desired lights are attached to sensors.

To detach a light from a sensor, do the following:

1. With the display showing `LIGHT 1 TO SENSOR y (current setting)`, press **A** or **B** to select the light number.
2. Enter **0** as the sensor number and press #.

## System version menu

The *System version* menu lets you view and identify panel hardware and software. This information is primarily used for troubleshooting purposes.

### **System version (factory code: 010, system number: 011, system level: 012, software version: 013)**

This menu lets you view and identify panel hardware and software version.

To view and identify the system version, do the following:

1. Press **A** or **B** until the display shows `SYSTEM VERSION`.
2. Press **#** and the display shows `FACTORY CODE nnn*nnnn`.
3. Press **B** and the display shows `SYSTEM NUMBER *nnnnnnnn`.
4. Press **B** again and the display shows `SYSTEM LEVEL nnnn`.
5. Press **B** again and the display shows `SW VERSION nnnnx` (panel firmware version).

## Downloader programming

The panel can be programmed remotely using Enterprise Downloader. Use the information you recorded in *Appendix A, System planning sheets* to inform the downloading operator of the programming requirements for this system.

A Downloader phone number should be programmed and the user-programmable option *Downloading* must be powered on for remote downloader programming to work. Downloader programming has not been investigated by UL.

To initiate an Enterprise Download session, do the following:

1. Contact your download station and ask the operator to prepare to download to the panel.
2. Make sure the system is disarmed.
3. Press **8** + *system master code* + **7 + 0** (any), **1** (down), or **2** (up). The display shows SYSTEM DOWNLOAD IN PROGRESS during the downloading process.

If the alphanumeric touchpad does not display SYSTEM DOWNLOAD IN PROGRESS call the downloader operator to verify the downloader phone number. Also, make sure *Enterprise ToolBox* is set up properly. Refer to the *Troubleshooting* on page 126 if the problem persists.

## Testing the system

Before testing, we recommend that you close the panel cabinet door and the covers on all modules (mounted outside the cabinet.) The testing environment should match the system working environment.

You should test the system after installation or service and after adding or removing devices from the system. Refer to *Troubleshooting* on page 126 section if you do not achieve correct test results.

Testing the system includes:

- *Basic system commands*
- *Zones/sensors* on page 118
- *Phone communication* on page 119
- *Central station/pager communication* on page 119
- *Outputs and sirens* on page 121
- *Light control* on page 121
- *Energy saver module (ESM)* on page 122
- *Fixed display LCD touchpad chime and trouble beep tones* on page 122
- *Audio verification module communication* on page 123
- *Cellular backup communication* on page 124

## Basic system commands

Table 13 describes basic touchpad operating commands. For complete details on system operation, including user programming, refer to the *Concord 4 User Manual*.

Table 13. Basic touchpad commands

Command	System response
* (STATUS)	Indicates current system status
* + *	Indicates AC power, battery, and current system status
1 + CODE	Disarms system to OFF
2 + CODE	Arms system to STAY
2 (quick arm on)	Arms system to STAY
3 (quick arm on)	Arms system to AWAY
2 or 3 + CODE + 4 or 2 or 3 + 4	Arm system—no delay (no exit or entry delay)
5 + 2 or 3 + CODE or 5 + 2 or 3	Arms system silently (no arming status beeps)
* (STATUS)	Indicates current system status
7 + 1	Turns chime feature on and off
7 + 2	Turns energy saver on and off

Table 13. Basic touchpad commands

Command	System response
7 + 4	Partition jump without entering code (only if partition security option is off)
7 + 6	Identifies alarms in memory
7 + 7 + n (n = output number [1-6]) 1-2 = onboard outputs 3-6 = module outputs	Turns the output on or off. (This command is only functional after output text is entered into panel memory.)
8 + CODE + 2	Initiates a phone test
8 + CODE + 3	Initiates a sensor test
8 + installer CODE + 3	Initiates a dealer sensor test
8 + CODE + 6	Partition jump
8 + CODE + 8	View event history
0 + 0	Turns all controlled lights on and off
0 + n (n = light number 1-9)	Turns individual controlled light on and off

## Zones/sensors

Test sensors/zones after all programming is completed; whenever there is a change in environment, equipment, or programming; and whenever a zone- or sensor-related problem occurs.

If the system does not respond as described in the following procedure, see [Troubleshooting](#) on page 126.

**Note:** While the sensor test is a valuable installation and service tool, it only tests sensor operation for the current conditions. You should perform a sensor test after any change in environment, equipment, or programming.

To test zones/sensors, do the following.

1. Place all sensors and zones in their nonalarm state.
2. At an alphanumeric touchpad, enter the sensor test mode by pressing **8 + installer code + 3**. The touchpad sounds one beep and displays `SENSOR TEST`. The panel starts a 15-minute timer.
3. Trip each zone/sensor one at a time. Touchpads (and interior sirens) should sound one short, high-pitched beep, and the display should show the sensor name (or number) and `OK`.
4. Press the **Status** button when you think all zones/sensors are tested. The touchpad displays any untested sensors/zones and touchpad panics. If all sensors/zones and touchpad panics have been tested, the display shows `SENSOR TEST OK`.
5. Test any untested zones/sensors and touchpad panics.

**Note:** If you hear a long, low-pitched beep, proceed to [If a wireless sensor does not test](#).

6. The system stays in sensor test mode for 15 minutes. When less than 5 minutes remain, touchpads and interior sirens beep and the panel announces the remaining time over the speakers once every minute. After 15 minutes, the panel disarms to *Off* automatically. If you need more time to complete the sensor test, press **8 + installer code + 3** while the system is still in sensor test mode. This restarts the 15 minutes of test time.
7. When all sensors/zones and touchpad panics have been tested, press **1 + installer code** to exit sensor test mode.

### If a wireless sensor does not test

If touchpads display `SENSOR FAILURE` and sirens sound a long, low-pitched beep when a zone or sensor is tripped, this indicates that the wireless sensor signal strength is below acceptable limits affecting the sensor signal strength.

When possible, locate wireless sensors within 100 ft. of the panel. While a transmitter may have a range of 1,000 ft. (3000 m) or more out in the open, the environment at the installation site can have a significant effect on transmitter range. Refer to [Troubleshooting](#) on page 126 to resolve the problem.

For wireless sensors that don't respond, use an RF Sniffer (60-401) test tool to verify that the sensor is transmitting. Constant beeps from the RF Sniffer indicate a runaway (faulty) sensor. Remove the sensor batteries and replace the sensor.



## Phone communication

Do a phone test to check the phone communication between the panel and the central monitoring station.

To test phone communication, do the following:

1. Contact the central monitoring station to inform them that you are testing the system.
2. Press **8** + *system master code* + **2**. The display reads `PHONE TEST` and the touchpad sounds one beep. When the panel completes the test, the system returns to the previous arming level automatically.
3. If the display continues to show `PHONE TEST` for 90 seconds or more, enter **1** + *system master code* and refer to [Troubleshooting](#) on page 126.

## Central station/pager communication

After doing sensor and phone tests, check that the system is reporting alarms successfully to the central station or pager.



**CAUTION:** Be sure to contact the central monitoring station before activating outputs that trigger from an alarm condition.

---

Account numbers vary when displayed, depending on pager service. Account numbers are not displayed if *Streamlining* is turned on.

To test communication with the central station/pager, do the following:

1. Call the central station and tell the operator that you will be testing the system.
2. Arm the system.
3. Test each of the touchpad and wireless panic buttons and trip at least one sensor of each type (fire, intrusion, etc.) to verify correct operation.
4. Check pager displays to verify reports are received. Pagers display an event code, digit sensor number, and the last four digits of the account number. A pager display of `999 002 7468` indicates the following:
  - 999 (alarm condition)
  - 002 (sensor/zone in alarm or user number)
  - 7468 (last four digits of account number)
5. When you finish testing the system, call the central monitoring station to verify they received the alarms.

*Table 14* describes pager system event codes.

*Table 14. Pager system event codes*

Codes	System event
009	Zone restoral
111	System disarmed
115	Sensor test exit
118	Trouble condition cleared
119	Alarm canceled
222	System armed to STAY
333	System armed to AWAY
555	Phone/sensor test
888	System trouble condition
999	System in alarm

*Table 15* describes pager sensor/zone number and user number report codes.

*Table 15. Pager sensor/zone code and numbers*

Code	Sensor/zone or user number
000	System event not caused by a zone or user
001-096	Sensor/zone numbers 1 to 96
600-829	Regular user codes 0 to 229 used
830-837	Partition master code used
838-845	Partition duress code used
846	System master code used
847	Installer code used
848	Dealer code used
850	Quick arm used
851	Keyswitch sensor used
852	System armed Itself (during service or power-up)

## Outputs and sirens

You should test all outputs (onboard and SnapCard) to verify configuration programming.

**Note:** Be sure to contact the central monitoring station *before* activating outputs that trigger from an alarm condition.

To test outputs, do the following

1. Contact the central monitoring station to inform them you are testing the system.
2. Verify that all wiring at the panel and output devices is correct.
3. Activate the appropriate device to trigger each output as programmed.
4. Verify that each output responds according to the programmed configuration number. For outputs that trigger sirens, verify that the correct alarm sounds are produced from these sirens (see *Table 16*).
5. Contact the central monitoring station when you are finished testing.

*Table 16* describes the system alarm sounds you should hear for each alarm event.

Table 16. System alarm sounds

Alarm type	Alarm sound
Fire	Repeating series of three beeps
Police/Intrusion	Continuous tone
Auxiliary	Rapid beeps

## Light control

Test all lights plugged into X10 lamp modules to verify house code and light number settings.

To test light control, do the following:

1. Press **0 + 0** repeatedly to turn all lights on and off together.
2. Press **0 + 1** repeatedly to turn light 1 on and off.
3. Repeat step 2 for remaining lights (**0 + 2** for light 2, **0 + 3** for light 3, etc.).
4. Arm the system to *Away*. All lights plugged into modules set to Unit 1 (or set as entry lights) should turn on and stay on for 5 minutes. All lights plugged into modules set to Unit 2 should blink three times to indicate the arming level. Remaining lights should not be affected.
5. Disarm the system. If unit 1 (or entry) lights were on for an entry or alarm, they will turn off in 5 minutes. Unit 2 lights should blink once to indicate the system is off. Remaining lights should not be affected.
6. All lights should turn on and remain on during fire and auxiliary/medical alarms. All lights should flash during a police or intrusion alarm.

## Energy saver module (ESM)

Test the energy saver module to verify it overrides the thermostat.

**Note:** The system must have high- and low-temperature limits set to test the energy saver module.

To test the energy saver module, do the following:

1. Press \* (status) + \* (status) to display the system status, ENERGY SAVER OFF, and the present TEMPERATURE nn°. The temperature displayed (and/or announced) should match the house thermostat. If the temperatures do not match, refer to *Accessory modules - bus devices settings* on page 93.

**Note:** There is a 5-minute delay after the energy saver module returns control to the furnace/AC before it will override the furnace/AC again.

2. Press 7 + 2 to turn on the ESM. The display shows ENERGY SAVER ON and the ESM relay will click once.
3. Press 7 + 2 again to turn the ESM off. The display shows ENERGY SAVER OFF.

## Fixed display LCD touchpad chime and trouble beep tones

You can adjust the frequency (pitch) of chime and trouble beep tones from a fixed display touchpad to a more desirable or distinct tone, or to compensate for hearing impaired persons.

To change status tone pitch, do the following:

1. Press and hold the \* and 0 buttons together until you hear a steady tone, then release the buttons.

**Note:** Chime and trouble beep tones sound using the default frequency during, or within 15 seconds of, any button activity at that specific touchpad.

2. Press and hold 1 to lower the pitch or press and hold 2 to raise the pitch.
3. Release the button when the desired pitch is heard.

After about 15 seconds of no touchpad activity, the steady tone stops sounding.

## Touchpad display contrast

You can adjust touchpad displays for easier viewing to help compensate for lighting conditions in the touchpad location. The contrast adjustment lightens or darkens the text.

**Note:** Vacuum fluorescent displays do not have a contrast adjustment.

To adjust display contrast, do the following:

1. Enter configuration mode by pressing the D and 6 buttons together for at least two seconds. The display shows DA nnn.
2. Press and release the 1 and 2 buttons together repeatedly, until the desired contrast level is displayed.
3. Press \* and the display briefly shows DONE, then shows the time and date.

## Audio verification module communication

Test the audio verification module (AVM) from offsite and the central station to verify that it works properly.

You will need a helper and DTMF phone at an offsite location to perform this test. When testing the AVM from offsite you must follow these guidelines:

- Set the remote access feature to on (default).
- Set the audio verify feature to on.
- Set the system to a nonalarm state.
- Set the optional ring/hang/ring feature (default) to work with steps 1 and 2 below. Otherwise wait for 12 rings and the panel will pick up automatically.

To test the module from offsite, do the following:

1. The offsite helper calls the panel, lets the phone ring twice, and hangs up.
2. The helper must call the panel again in 10 to 40 seconds. The panel answers *System hello*. This works if you have a phone interface voice module (part #60-777-01) installed.
3. The helper dials the following on the phone, # 1234 # 8 (AVM access CODE) 5.
4. The helper should now be able to hear you through the AVM.
5. Walk through the vicinity of the AVM while speaking at a normal conversation level.
6. Tell the helper to dial a 1 and speak to you. To return to listen mode, the helper dials a 3.
7. When testing is complete, have the helper dial 99 and hang up.

To test the module with the central station, do the following:

1. Inform the central station that you will be sending an alarm and testing an AVM.
2. Give them the programming selections you made for the panel (see [Audio verification menu](#) on page 89 for programming information).
3. Use a panic button to initiate an auxiliary alarm.
4. The central station operator waits for the alarm to be reported and initiates an audio session.
5. Walk through the vicinity of the AVM while speaking at a normal conversation level.
6. Have the operator speak to you.
7. When testing is complete, the operator will end the session.

## Cellular backup communication

To check the cellular communication between the panel and the central monitoring station, do the following:

1. Contact the central monitoring station to inform them that you are testing the system.
2. Install and activate the SuperBus 2000 cellular backup module.
3. Verify or change the following CS phone panel option settings shown in *Table 17*:

Table 17. Cellular backup communication

CS phone 1 option	Test setting	Previous setting
Phone number	Central station phone number	
High level reports	On	
Backup	Off*	
Cellular backup	On	

\*Can be set to ON if no CS phone 2 phone number is programmed.

**Note:** If the current settings do not match the test settings, record the current settings (*Table 16* on page 121), so that they can be restored when this test is complete.

4. Disconnect the phone line by unplugging the DB-8 cord from the RL 31X jack.
5. Initiate a phone test (**8 + system master code + 2**).
6. The phone test attempt should fail via the phone line within 5 minutes. The panel will emit a long low tone (and speak “phone failure 1” if so equipped).
7. Wait for the phone test to succeed via the cell backup. The panel should emit a short high tone (and speak “phone test okay” if so equipped).
8. Verify the CS report.
9. If success does not occur, verify that the signal strength (RSSI) shown on the cellular backup module is acceptable and repeat the process.

# Chapter 4 Troubleshooting, maintenance, support

This chapter provides information to help you troubleshoot problems, perform simple preventive maintenance procedures, and contact technical support in case you need assistance with your GE equipment.

In this chapter:

<i>Troubleshooting</i> .....	126
<i>Troubleshooting your Concord 4 system</i> .....	126
<i>Maintenance</i> .....	126
<i>Contacting technical support</i> .....	133
<i>Online publication library</i> .....	133

## Troubleshooting

This section provides information to help you diagnose and solve various problems that may arise while configuring or using your GE product.

### Panel power issues

- *What transformer does Concord 4 use?*

Concord 4 uses a 16.5 VAC transformer, (600-1023 or 600-1024 with power line carrier). Concord 3 uses a 24 VAC transformer. Using a 24 VAC transformer on Concord 4 damages the panel.

- *The panel does not power up and touchpads don't display or respond. What's wrong?*

This could be caused by a number of things. Do the following:

1. Verify that the panel transformer is plugged into an unswitched outlet.
  2. Check the AC circuit breaker to be sure the circuit is live.
  3. Check that the backup battery is installed correctly and the AC power transformer is plugged in.
  4. Check for proper panel and transformer wiring.
  5. Measure the incoming AC voltage at panel terminals 1 and 2. It should read about 16.5 VAC.
- *I get no incoming AC voltage at panel terminals 1 and 2.*
    1. Unplug the AC power transformer and disconnect the wires from the transformer and the panel.
    2. Check transformer to panel wire for short or open circuits.
    3. Plug in the transformer and check for 16.5 VAC at the transformer unconnected terminals. If it shows zero (0) volts, replace the transformer.



**WARNING:** Do not check for voltage by touching two live wires together. This may damage the transformer.

---

- *Touchpad display indicates System Low Battery or voice sounds "System low battery."*
  1. Check that the backup battery is installed correctly and the AC power transformer is plugged in.
  2. Measure the incoming AC voltage at panel terminals 1 and 2. It should read about 16.5 VAC.
  3. Check for 11.75 to 13.8 VDC battery voltage between the backup battery spade lugs. If the battery voltage is **not** within this range, replace the battery.

**Note:** When the panel is running a backup battery test, the reading at the connected battery can range from 11.2 to 13.5 VDC. The panel automatically runs a backup battery test under the following conditions: (1) on initial power-up, (2) during user sensor test, (3) once every minute when backup battery has failed, (4) once every 24 hours at the programmed STIME (UL 98 Options off) or once every 4 hours (UL 98 Options on).

With the AC power transformer plugged in, the panel automatically charges the battery. While the battery is charging for the first time it is normal for the system to indicate System Low Battery. This can take a number of hours depending on the initial battery charge. Once the battery reaches 12.5 VDC (full charge as measured while in battery test), the condition clears. If the trouble condition persists after 24 hours, replace the backup battery.



- *The touchpads flash AC or display AC Power Failure/AC Failure After pressing STATUS the panel continues to operate from backup battery.*

This could be caused by a number of things. Do the following:

1. Check the AC circuit breaker to be sure the circuit is live.
2. Check for proper panel and transformer wiring.
3. Check that the transformer is plugged into a nonswitched outlet and secured with the provided screw.
4. Check that the transformer is supplying AC to the panel.



**WARNING:** Be careful when securing the transformer to an outlet with a metal cover. Hold the cover tightly in place. You could receive a serious shock if the metal outlet cover drops down onto the prongs of the plug while you are securing the transformer and cover to the outlet box.

---

### Access code issues

- *Customer cannot remember access codes.*
  1. Check your records to see if you have the customer's access codes on file.
  2. Verify the access codes using the Enterprise Downloader software.
  3. Clear memory and reprogram the panel locally. Clearing the memory erases all programming.
- *Installer cannot remember install code.*
  1. Check your records to see if you have the install code on file.
  2. Verify the install code using the Enterprise Downloader software.
  3. Use the dealer code to enter program mode and view the installer code.

- *Installer cannot remember dealer code.*

Check your records to see if you have the dealer code on file. If you don't have dealer codes, you need to replace the panel.

### Arming and disarming issues

- *System protests and won't arm.*

If arming to level 2, make sure all monitored perimeter doors and windows are closed.

If arming to level 3, make sure all perimeter and interior sensors are closed.

Press STATUS for an indication of the problem.

- *System won't disarm.*

1. You may be trying to disarm using an incorrect code. Verify correct code and enter it.
2. Access code is not programmed or set up in user programming to disarm system. Wireless touchpad is not learned into system or hardwired touchpad is not communicating to panel.
3. The installer code is being used to disarm the system. The system is designed *not to disarm* using the installer code. Use a regular or system master code to disarm the system.

### **Bypassing issues**

- *Touchpad indicates Invalid and/or “Invalid” is heard when you attempt to bypass a sensor.*
  1. You may be attempting to bypass a 24-hour sensor that cannot be bypassed (group 26 fire sensors).
  2. The sensor is not active in the current arming level.
  3. Arm the system to the desired arming level, then bypass.
- *System cancels sensor bypass when you try to arm to level 2 or 3.*

Sensor is being bypassed before arming to 2—STAY or 3—AWAY. Arm to the desired level before bypassing a sensor.

### **Wireless sensor and touchpad battery issues**

- *System indicates Sensor/Touchpad low battery.*

Replace the indicated device battery. Test the sensor/touchpad after replacing the battery.

### **Central station/pager reporting issues**

- *Having trouble with your central station or pager?*

With reporting to CS or pager three things must be checked: Programming, connecting to the panel, and having a proper phone line with line seizure.

To check your programming, do the following:

1. Make sure you enter the correct phone number.
2. Make sure you enter the correct account number.
3. Check that the appropriate format is chosen (SIA or CID).
4. Make sure the appropriate reports are turned on.

To check your panel connections, do the following:

1. Concord panels are polarity sensitive, so check for proper polarity:
  - a. The positive green lead or (TIP) wires must connect to terminal 25 on the board.
  - b. The negative red lead or (RING) wires must connect to terminal 28 on the board.
2. Concord panels are voltage sensitive, so it's necessary to check for proper voltage:
  - a. Onhook voltage should be approximately 48-52 volts.
  - b. Offhook voltage should be approximately 6-10 volts.

**Note:** The Concord panel has a built-in line voltage meter. If it does not see proper voltage, it will not dial on a tone phone line. This does not apply to a pulse phone line.

To check proper phone line with line seizure, do the following:

1. Check the type of phone line. Concord panels work with analog phone lines or DSL with a DSL filter inline to the panel. VOIP or digital phone lines may not work with the panels.
2. Check that the premise's phone line is working.
3. Check that the DB-8 cord is plugged into the RJ31X/CA-38A jack.

4. Check for correct phone line wiring between the TELCO block and the RJ31X/CA-38A jack.

### Alphanumeric touchpad issues

- *Display shows all \*\*\*\*\**.  
Touchpad is not connected to panel bus terminals or is wired incorrectly. Check and correct wiring.
- *Display is blank.*  
Check that panel is powered up.  
Check for touchpad power and/or bus miswiring, opens, or shorts.  
Check touchpad brightness setting. (See [Options menu](#) on page 110.)
- *Touchpad buttons don't beep when pressed.*  
Check for touchpad power and/or bus miswiring, opens, or shorts.  
Check that key beeps option is set to on. (See the [Accessory modules - bus devices settings](#) on page 95.)

### Fixed display touchpad issues

- *Display is lit but does not respond to key presses.*  
Touchpad is not connected to panel bus terminals or is wired incorrectly. Check and correct wiring.  
Check that touchpad is learned into panel memory.
- *Display is blank.*  
Check that panel is powered up.  
Check for touchpad power and/or bus miswiring, opens, or shorts.  
Check touchpad brightness setting. (See the user-programming [Options menu](#) on page 110.)
- *Touchpad buttons don't beep when pressed.*  
Check for touchpad power and/or bus miswiring, opens, or shorts.  
Check that key beeps option is set to on. (See the [Accessory modules - bus devices settings](#) on page 95.)

### Speaker issues

- *Speakers don't sound alarms.*  
Speaker output has shut down because panel detected terminal 7 or 8 is shorted to ground. Disconnect panel AC and battery backup power. Locate short and correct. Apply panel AC and backup battery power and retest.  
  
Alarm is in partition 2 to 6 and speaker is connected to panel terminals 7 and 8, which activate only for partition 1 alarms.

### Siren issues

- *Piezo sirens connected to SnapCard, or onboard (panel) outputs 1 and/or 2 don't produce any alarm sounds.*  
Check for incorrect wiring between siren and panel; correct where necessary.  
  
Output has not been configured (set up) to activate sirens. Enter program mode and configure output. (See [Accessory modules - bus devices settings](#) on page 95.)

Check for correct output partition assignment.

Check that your wires are connected to the appropriate terminals:

1. Output 1 (exterior) uses terminals 9 (positive) and 13 (ground).
2. Output 2 (interior, follows status beeps) uses terminals 11 (positive) and 10 (ground).

### Hardwired zone issues

- *System doesn't go into alarm when zone is tripped.*

System is disarmed. Arm system and then trip the zone.

Zone is not learned into panel memory. Enter installer/dealer program mode—*LEARN SENSORS*, and learn zone into memory.

Zone is learned into wrong partition. Delete zone and learn into correct partition or change the partition in the *EDIT SENSORS* menu.

For Hardwire Input Module (HIM) zones, check that the HIM LED is blinking to verify communication with the panel. If LED is off, check wiring between HIM and panel.

- *Zone reports trouble condition.*

Check that onboard, HIM, and SnapCard zone inputs have a 2 kohm EOL resistor installed at the last device on the loop in series for NC loops, in parallel for NO loops.

Check for zone wire fault—short circuit on NC loops, open circuit on NO loops.

### Wireless sensor zone issues

- *System doesn't respond (in sensor test or when armed) when sensor is tripped.*

Verify that receiver antennas are routed through holes on top of enclosure and antenna shrouds are installed.

Check that the wireless sensor batteries are installed.

Check the sensor batteries for low voltage. Replace batteries if necessary.

Use an RF Sniffer (60-401) to verify that sensor is transmitting.

Sensor is not learned into panel memory. Enter installer/dealer program mode—*LEARN SENSORS*, and learn sensor into memory.

Zone is learned into wrong partition. Delete zone and learn into correct partition or change the partition in the *EDIT SENSORS* menu.

- *Sensor reports trouble condition.*

Sensor tamper switch is tripped—sensor cover is off, not latched securely, or sensor is not mounted securely. Secure sensor mounting and/or cover, then trip sensor to clear the condition.

Check the sensor battery for low voltage. Replace batteries, if necessary.

- *Touchpad indicates [sensor #] supervisory.*

Use an RF Sniffer (60-401) to verify that sensor is transmitting. If sensor is not transmitting, check battery for low or no voltage and replace.

Change mounting position of sensor (from horizontal to vertical or vice versa) and test sensor several times for consistency.

Sensor signal is not reaching panel/receiver because sensor is too far away. Remove sensor from mounted location and test from other locations. Mount sensor in area where signal can reach panel/receiver or install a SuperBus 2000 RF transceiver in the vicinity of the sensor. You may also install a Repeater 80-922-1 to boost signal.

- *Smoke sensor beeps intermittently.*

Sensor batteries are getting low. Replace batteries.

### Wireless touchpad issues

- *System doesn't respond to commands entered from wireless touchpad.*

Verify that receiver antennas are routed through holes on top of enclosure and antenna shrouds are installed.

Check that touchpad batteries are properly installed.

Check the touchpad batteries for low voltage. Replace batteries, if necessary.

Use an RF Sniffer (60-401) to verify that touchpad is transmitting.

Touchpad is not learned into panel memory. Enter program mode and learn touchpad into memory (see [Sensors menu](#) on page 85).

Touchpad is learned into wrong partition. Delete touchpad and learn into correct partition or change the partition in the [Sensors menu](#) on page 85.

- *Touchpad reports trouble condition.*

Check the touchpad batteries for low voltage. Replace batteries, if necessary.

### Phone issues

- *Loss of dial tone at onsite phones after wiring RJ31X jack or connecting the DB-8 cord.*

Wait two minutes and try again. The panel may be busy trying to report to the central station.

Disconnect the panel DB-8 cord from the RJ31X jack. If the phone still doesn't work, the system is okay and the problem is in the wiring.

Check RJ31X jack wiring and TELCO block wiring. Replace RJ31X jack if necessary.

Check DB-8 cord connections at the panel and RJ31X jack. Replace cord if necessary.

Perform a phone test after troubleshooting the phone line.

- *Constant dial tone, preventing dial-out on premises phones.*

One or more polarity-sensitive phones exist on-site. Reverse the phone wires connected to the brown and gray wire terminals on the RJ31X jack.

### Light control issues

- *Light controlled by X10 lamp module is not working.*

Partition house codes are not programmed into panel. Enter program mode and set partition house codes.

Check that the HOUSE dial on the X10 module matches the partition house code programmed into the panel.

Panel is not powered by a power line carrier transformer. Replace existing transformer with a power line carrier transformer.

Check to make sure X10 module is not plugged into an outlet controlled by a switch. Move to a nonswitched outlet location and test.

Check that the lamp has a working bulb and that the lamp switch is on.

Power transformer and X10 modules are not plugged into outlets on the same electrical phase. Relocate modules or transformer to different outlets to determine working locations.

### Energy saver module issues

- *Module does not respond to system commands or appear to control furnace.*

Check that the module is wired correctly to the panel terminals.

Verify the module LED is flashing continuously. If the LED is not flashing, remove power and check wiring.

There is a five minute delay after the module returns control to the furnace/AC thermostat, before the module overrides the thermostat again. Wait five minutes and try again.

- *Module temperature does not match actual room temperature.*

The module room temperature setting has not been adjusted or was adjusted before the module warmed or cooled to room temperature. To ensure accuracy, wait at least 15 minutes after installing the module before adjusting the temperature. To adjust the module room temperature setting, see *Temperature* under the [Unit-ID \(10000 to 10015\)](#) on page 93.

### Automation module issues

- *Module is not controlling or communicating with the panel and panel indicates a “BUS FAILURE UNIT nn” where nn is the automation module bus unit number.*

Check that the module is wired correctly to the panel terminals.

Verify the SuperBus module’s red LED is flashing continuously. If the LED is not flashing, remove power and check wiring.

Check that the RS-232 cable is firmly connected to the automation module and the automation device.

Verify the automation device is powered and turned on.

- *Module is not controlling or communicating with the panel and panel does not indicate a bus failure.*

Verify the automation module is learned into panel memory.

## Contacting technical support

For assistance installing, operating, maintaining, and troubleshooting this product, refer to this document and any other documentation provided. If you still have questions, you may contact technical support during normal business hours (Monday through Friday, excluding holidays, between 5 a.m. and 5 p.m. Pacific Time).

Table 18. Service and support contact information

	Customer service	Technical support
Phone	Toll-free: 888.GESECURity (888.437.3287) in the US, including Alaska and Hawaii; Puerto Rico; Canada. Outside the toll-free area: 503.885.5700.	
E-mail	<a href="mailto:gesecurity.customerservice@ge.com">gesecurity.customerservice@ge.com</a>	<a href="mailto:nstechsrv@ge.com">nstechsrv@ge.com</a>

**Note:** Be ready at the equipment before calling for technical support.

## Online publication library

Another great resource for assistance with your GE product is our online publication library. To access the library, go to our website at the following location:

<http://www.gesecurity.com>

In the **Customer Support** menu, select the *Resource Library* link. After you register and log on, you may search through our online library for the documentation you need.<sup>1</sup>

---

1. Many GE documents are provided as PDFs (portable document format). To read these documents, you will need Adobe Reader, which can be downloaded free from Adobe's website at [www.adobe.com](http://www.adobe.com).





# Appendix A System planning sheets

This appendix provides a list of the various system planning sheets for the Concord 4.

In this appendix:

<i>System planning sheets</i> .....	140
<i>Wireless devices</i> .....	140
<i>Hardware devices</i> .....	141
<i>Zone and sensor assignments</i> .....	143
<i>System settings index and record</i> .....	146

## System planning worksheets

Table 19. Customer information

Customer name	
Address	
City	
County	
State	
Zip	
Phone	

Table 20. Wireless devices

Part no.	Description	Qty.
60-362	Door/window sensor	
60-670-95R	SAW door/window sensor	
60-741-95	Micro recessed door/window sensor	
60-499	Slim line door/window sensor	
60-688*	Micro door/window sensor	
60-641	Long-life door/window sensor	
60-461*	Shock sensor	
60-459	Sound sensor	
60-462*	Glass guard sensor	
60-506	System sensor smoke sensor	
60-838-95R	2100ARFT smoke sensor	
60-848-02-95	ESL 562 smoke sensor	
60-460	Rate-of-rise heat sensor	
60-589	Manual fire pull sensor	
60-504*	Freeze sensor	
60-452	Pendant panic sensor	
60-458	Single button panic sensor	
60-457	Dual button panic sensor	
60-578	Water-resistant panic sensor	
60-511-01-95*	DS924i PIR motion sensor	

Part no.	Description	Qty.
60-639-95R	SAW indoor PIR motion sensor	
60-639-95R-OD	SAW outdoor PIR motion sensor (not for intrusion protection)	
60-703-95	Crystal indoor PIR motion sensor	
60-834-95R	Adjustable dual technology sound sensor	
60-597	HiTech handheld wireless touchpad	
60-607*	2-button keyfob touchpad	
60-606*	4-button keyfob touchpad	
60-659-95R*	SAW 4-button keyfob touchpad	
60-832-95R*	2-button ELM keyfob touchpad	

Table 21. Hardware devices

Part no.	Description	Qty.	mA (max.)	Subtotal
<b>Hardwire sensors/detectors</b>				
N/A	System sensor models 2400, or 2400TH or ESL series 429AT, 429C, 429CT, 521B, 521BXT, 521NCSXT, 711U, 711UT, 721U, 721UT, TS7-2, or TS7-2T		80 mA††	
13-082*	PIR motion detector		10 mA	
<b>Sirens</b>				
13-046	Hardwire exterior siren		145 mA	
13-949**	Hardwire interior siren		85 mA	
13-950**	Piezo dynamic exterior siren		150 mA	
<b>SuperBus 2000/miscellaneous components</b>				
60-746-01	2x16 LCD alphanumeric touchpad		90 mA	
60-820	Fixed display LCD touchpad		65 mA	
600-1020	FTP 1000		75 mA	
60-803	2x20 LCD alphanumeric touchpad		120 mA	
60-804	2x20 VFD alphanumeric touchpad		120 mA	
60-983	ATP 1000		110 mA	
60-984	ATP 2600		165 mA	
60-985	ATP 2100		300 mA	
600-1013*	GTS 50		300 mA	

Table 21. Hardware devices

Part no.	Description	Qty.	mA (max.)	Subtotal
60-836	Voice only module (with current jumper installed) (with current jumper removed)		600mA	
60-777-01	Phone interface/voice module		600 mA	
600-1025-01-95R	RF transceiver		55 mA	
60-764-01-95R	RF receiver		35 mA	
600-1019	2-amp power supply		N/A	
60-756	4 input/2 output SnapCard		185 mA	
60-757	8Z hardwired zone expander SnapCard		230 mA	
60-758	4 output SnapCard		130 mA	
60-774	Hardwired input module		35 mA	
60-770	Hardwired output module		180 mA	
60-620-01*	Energy saver module		20 mA	
60-850	Cellular backup module (standard power)		1600 mA	
60-850-01	Cellular backup module (high power)			
60-861	Wireless gateway-ready kit		1900 mA	
60-677*	Interrogator 200 audio verification module		1600 mA	
60-783-02*	Automation module		10 mA	
60-528	Hardwired interior speaker		35 mA	
13-060	15-watt speaker		500 mA	
<b>Total power consumption:</b>				mA
<b>Total power consumption not to exceed:</b>				1,000 mA

\* These devices not listed, investigated, or verified by UL.

\*\* UL listing applied for.

† Listed, but not tested for compatibility by UL.

†† Total current only for all 2-wire smoke detectors connected to panel 2-wire smoke loop.

**Note:** When installing SuperBus 2000 RF receiver modules, the antenna tamper feature must be set to off. (see [Reporting - global settings](#) on page 73).

Table 22. Zone and sensor assignments

No.	RF zone	Module bus ID number	Module input number	Group	Partition	Zone/sensor text
1						
2						
3						
4						
5						
6						
7						
8						
9						
10						
11						
12						
13						
14						
15						
16						
17						
18						
19						
20						
21						
22						
23						
24						
25						
26						
27						
28						
29						

Table 22. Zone and sensor assignments

No.	RF zone	Module bus ID number	Module input number	Group	Partition	Zone/sensor text
30						
31						
32						
33						
34						
35						
36						
37						
38						
39						
40						
41						
42						
43						
44						
45						
46						
47						
48						
49						
50						
51						
52						
53						
54						
55						
56						
57						
58						
59						

Table 22. Zone and sensor assignments

No.	RF zone	Module bus ID number	Module input number	Group	Partition	Zone/sensor text
60						
61						
62						
63						
64						
65						
66						
67						
68						
69						
70						
71						
72						
73						
74						
75						
76						
77						
78						
79						
80						
81						
82						
83						
84						
85						
86						
87						
88						
89						

Table 22. Zone and sensor assignments

No.	RF zone	Module bus ID number	Module input number	Group	Partition	Zone/sensor text
90						
91						
92						
93						
94						
95						
96						

Table 23. System settings index and record

Setting (reference) default	Shortcut no.	Setting
Installer programming—8 + installer/dealer CODE + 00		
24-hour tamper off	06000	
AC failure off	06011	
Access code lock (on)	0003	
Access timeout 90 sec.	09004	
Account no. 00000	0010-0060	
Activity timeout 24 hrs	0305	
Alarm verify off	06108-06608	
Antenna tamper off	06001	
Audio mode 1	09001	
Audio verify off	09000	
Auto phone test off	02001	
Auto test reset on	02002	
Auxiliary panic on	0511-0561	
Aux power fail on	06016	
AVM access code none	09006	
Back in service on	06003	
Backup CS phone 1 on, CS phone 2-3 off	01005, 01015, 01025	1 _____ 2 _____ 3 _____
Battery restoral off	06006	



Table 23. System settings index and record

Setting (reference) default	Shortcut no.	Setting
Beep delay 2 sec	09005	
Buffer control off	06002	
Buffer full report off	06007	
Bypass reports off	06004	
Call wait cancel none	02009	
Cancel message on	02007	
Cellular backup CS phone 1 on, CS phone 2-3 off	01007, 01017, 01027	1 _____ 2 _____ 3 _____
Cellular system B		
Closing reports off	06101 - 06601	
Comm. failure on	02003	
CS phone 1-3 none	01000, 01010, 01020	
Daylight saving on	0307	
Dealer code none	0002	
Delete sensors none	082	
Dial tone detect on	02010	
Dial abort delay 30 sec	02006	
Disable trouble beeps off	0701	
Downloader code 12345	0000	
Downloader phone no. none	01090	
DTMF dialing on	02004	
Duress code none	0016-0066	
Duress option off	06103-06603	
Edit sensors none	083	
Entry delay 30 sec	0310-0360	
Exception reports (phones) off	01003, 01013, 01023	1 _____ 2 _____ 3 _____
Exception reports (pagers) off	01033, 01043, 01053, 01063, 01073	1 _____ 2 _____ 3 _____ 4 _____ 5 _____
Exit delay 60 sec	0311-0361	

Table 23. System settings index and record

Setting (reference) default	Shortcut no.	Setting
Exit extension on	0013-0063	
Extended delay 4 min	0312-0362	
Fire panic on	0510-0560	
Fire shutdown off	09002	
Force armed off	06104-06604	
Freeze alarm off	06106-06606	
Freeze temp 42	06107-06607	
Global fire off	0703	
Ground fault on	06017	
High level reports (phones) CS phone 1 On, CS phone 2-3 off	01001, 01011, 01021	1 _____ 2 _____ 3 _____
High level reports (pagers) on	01031, 01041, 01051, 01061, 01071	1 _____ 2 _____ 3 _____ 4 _____ 5 _____
House code 1B, 2C, 3D, 4E, 5F, 6G	0401-0451	
Immediate beeps off	0700	
Installer code 4321	0001	
Keyfob arming off	0513-0563	
Keyfob PTN	0006	
Keyswitch sensor none	0014-0064	
Keyswitch style transition	0015-0065	
Latchkey format off	06105-06605	
Latchkey reports (pagers) on	01035, 01045, 01055, 01065, 01075	1 _____ 2 _____ 3 _____ 4 _____ 5 _____
Latchkey zones none	0500	
Learn sensors none	080	
Line fail delay none	0213	
Local phone control on	0210-0260	
Low CPU battery on	06005	
Low level reports (phones) CS phone 1 on, CS phone 2-3 off	01002, 01012, 01022	1 _____ 2 _____ 3 _____
Low level reports (pagers) off	01032, 01042, 01052, 01062, 01072	1 _____ 2 _____ 3 _____ 4 _____ 5 _____

Table 23. System settings index and record

Setting (reference) default	Shortcut no.	Setting
Manual mic gain	09009	
Multiple-partition arm off	0005	
Next phone test 7 days	0304	
No activity off	06102 - 06602	
Open/close reports (phones) off	01004, 01014, 01024	1 _____ 2 _____ 3 _____
Open/close reports (pagers) off	01034, 01044, 01054, 01064, 01074	1 _____ 2 _____ 3 _____ 4 _____ 5 _____
Opening reports off	06100-06600	
Onboard output 1 01614 - any audible alarm	11101	
Onboard output 2 01710 - status & alarm tones	11111	
Output trip time 4 sec	0305	
Pager delay 15 sec	02008	
Pager partition assignment 1	01037, 01047, 01057, 01067, 01077	1 _____ 2 _____ 3 _____ 4 _____ 5 _____
Pager phone 1 to 5 none	01030, 01040, 01050, 01060, 01070	1 _____ 2 _____ 3 _____ 4 _____ 5 _____
Partition security on	0004	
Phone access key #	0216-0266	
Phone panic off	0215-0265	
Phone test on	02000	
Phone test freq. 7 days	0303	
Police panic on	0512-0562	
Program report off	06015	
Quick arm off	0011-0061	
Quick exit on	0012-0062	
Receiver failure off	06012	
Remote access on	0211-0221	
RF low battery rpt weekly	06013	
RF supervisory rpt weekly	06014	

Table 23. System settings index and record

Setting (reference) default	Shortcut no.	Setting
RF TX timeout 12 hrs	0302	
Ring/hang/ring on	0212-0262	
Reporting format (SIA/CID)	01006, 01016, 01026	1 _____ 2 _____ 3 _____
Sensor text none	081	
Silent talkback off	09003	
Siren timeout 4 min	0313-0363	
Siren verify off	0710	
Sleep time off	0314-0364	
Smoke verify off	1100	
SnapCard output 1 (01400 - keyfob star button activation)	101101	
SnapCard output 2 (00410 - any audible alarm)	101111	
SnapCard output 3 (00903 - arming to STAY or AWAY)	101121	
SnapCard output 4 (01003 - arming to AWAY)	101131	
Star is no delay off	0514-0564	
Streamlining on	01036, 01046, 01056, 01066, 01076	1 _____ 2 _____ 3 _____ 4 _____ 5 _____
Supervisory time 03:00	0300	
Swinger limit 1	06015	
System tamper off	06109-06609	
Toll saver on	0214-0264	
TP panic RPT FMT off	06010	
Two-trip error off	06009	
2-wire smoke off	1101	
UL 98 options off	0702	
VOX gain range	09008	
VOX mic gain	09007	
VOX RX gain	09010	
Zone restorals off	06008	

## Appendix B Settings

This appendix provides a list of alarm panel settings.

## Settings

Table 24 shows a higher view of menu navigation. Table 25 shows detailed menu navigation. To navigate through your system menus, use *A* and *B* to scroll through across main menus, and at times up and down through submenus. The # and \* buttons scroll you up and down through most submenus.

Table 24. Navigation hierarchy

<b>System programming</b>		CS phone 2 (continued)	
Demo kit on off		Reporting format SIA CID (01016)	
Partition 1 copy		Celular backup on <u>off</u> (01017)	
Clear memory		CS phone 3	
Exit programming		Phone number none (01020)	
<b>Security</b>		High lvl rpts on off (01021)	
Global		Low lvl rpts on off (01022)	
Downloader code 12345 (0000)		Exception rpts on off (01023)	
Installer code 4321 (0001)		Open/close rpts on off (01024)	
Dealer code **** (0002)		Backup on off (01025)	
Access code lock on off (0003)		Reporting format SIA CID (01026)	
Ptn security on off (0004)		Cellular backup on off (01027)	
Multi ptn arm none (0005)		Pager 1	
Keychain TP ptn (0006)		Phone number none (01030)	
Partition		High lvl rpts on off (01031)	
Account number 00000 (0010-0060)		Low lvl rpts on <u>off</u> (01032)	
Quick exit <u>on</u> off (0012 - 0062)		Exception rpts on <u>off</u> (01033)	
Exit extension on off (0013 - 0063)		Open/close rpts <u>on</u> off (01034)	
Quick exit <u>on</u> off (0012-0062)		Latchkey rpts <u>on</u> off (01035)	
Keyswitch sensor none (0014 - 0064)		Streamlining <u>on</u> off (01036)	
Keyswitch style <u>transition</u> state (0015 - 0065)		Ptn assignment <u>123456</u> (01037)	
Duress code **** (0016 - 0066)		Pager 2	
<b>Phones</b>		Phone number none (01040)	
CS phone 1		High lvl rpts on off (01041)	
Phone number none (01000)		Low lvl rpts <u>on</u> off (01042)	
High lvl rpts on off (01001)		Exception rpts on <u>off</u> (01043)	
Low lvl rpts <u>on</u> off (01002)		Open/close rpts on <u>off</u> (01044)	
Exception rpts on <u>off</u> (01003)		Latchkey rpts <u>on</u> off (01045)	
Open/close rpts on <u>off</u> (01004)		Streamlining <u>on</u> off (01046)	
Backup on off (01005)		Ptn assignment <u>123456</u> (01047)	
Reporting format SIA CID (01006)		Pager 3	
Cellular backup <u>on</u> off (01007)		Phone number none (01050)	
CS phone 2		High lvl rpts on off (01051)	
Phone number none (01010)		Low lvl rpts <u>on</u> off (01052)	
High lvl rpts on <u>off</u> (01011)		Exception rpts on <u>off</u> (01053)	
Low lvl rpts on <u>off</u> (01012)		Open/close rpts on <u>off</u> (01054)	

Exception rpts on <u>off</u> (01013)
Open/close reports on <u>off</u> (01014)
<b>Timers</b>
Pager 4
Phone number none (01060)
High lvl rpts on off (01061)
Low lvl rpts <u>on</u> off (01062)
Exception rpts on <u>off</u> (01063)
Open/close rpts on <u>off</u> (01064)
Latchkey rpts <u>on</u> off (01065)
Streamlining <u>on</u> off (01066)
Ptn assignment_123456 (01067)
Pager 5
Phone number none (01070)
High lvl rpts on off (01071)
Low lvl rpts <u>on</u> off (01072)
Exception rpts on <u>off</u> (01073)
Open/close rpts on <u>off</u> (01074)
Latchkey rpts <u>on</u> off (01075)
Streamlining <u>on</u> off (01076)
Ptn assignment_123456 (01077)
Downloader phone
Phone number none (01090)
<b>Phone options</b>
Global
Phone test on off (02000)
Auto phone test on off (02001)
Auto test reset on off (02002)
Comm failure on off (02003)
DTMF dialing on off (02004)
Dial abort relay 30 sec (15-45) (02006)
Cancel message on off (02007)
Pager delay 15 sec (0-30) (02008)
Call wait cancel on off (02009)
Dial tone detect on off (02010)
Partition
Local phone ctrl on off (0210-0260)
Remote access on off (0211-0261)
Ring/hang/ring on off (0212-0262)
Line fail delay none (10-240 sec) (0213-Ptn 1 only)
Toll saver on off (0214-0264)
Phone panic on off (0215-0265)
Phone ACC key # * (0216-0266)

Latchkey rpts <u>on</u> off (01055)
Streamlining <u>on</u> off (01056)
Ptn assignment_123456 (01057)
Global (continued)
Next phone test 7 days (1-255) (0304)
Output trip time 4 sec (1-12) (0305)
Activity timeout 24 hours (1-42) (0306)
Daylight saving on off (0307)
Partition
Entry delay 30 sec (30-240) (0310-0360)
Exit delay 60 sec (45-184) (0011-0061)
Extended delay 4 min (1-8) (0312-0362)
Siren timeout 4 min (1-30) (0313-0363)
Sleep time 22:00 (00:00-23:50) (0314-0364)
No usage time none (2-555 min.) (0315-0365)
<b>Light control</b>
Partition
Entry lights none (3-9) (0400 - 0450)
House code1B 2C 3D 4E 5F 6G (0401 - 0451)
<b>Touchpad options</b>
Global
Latchkey zones none (1-96)
Partition
Fire panic on off (0510 - 0560)
Auxiliary panic <u>on</u> off (0511 - 0561)
Police panic <u>on</u> off (0512 - 0562)
Keychain TP arm on <u>off</u> (0513 - 0563)
Star is no delay on <u>off</u> (0514 - 0564)
<b>Reporting</b>
Global
24-hour tamper on off (06000)
Antenna tamper on off (06001)
Buffer control on off (06002)
Back in service <u>on</u> off (06003)
Bypass reports on <u>off</u> (06004)
Partition
Opening reports on off (06100 - 06600)
Closing reports on <u>off</u> (06101 - 06601)
No activity on <u>off</u> (06102 - 06602)
Duress option on <u>off</u> (06103 - 06603)
Duress option on <u>off</u> (06103 - 06603)
Force armed on <u>off</u> (06104 - 06604)
Latchkey format on <u>off</u> (06105 - 06605)

<b>Timers</b>	
Global	
	Supervisory time 1:00 - 4:00 (random) (0300)
	System tamper on <u>off</u> (06109 - 06609)
	Report confirm on <u>off</u> (06111 - 06611)
	RF supv rpt daily <u>weekly</u> (06014)
	Swinger limit <u>1</u> (1-2) (06015)
	Aux power fail <u>on</u> <u>off</u> (06016)
<b>Timers</b>	
Global	
	Immediate beeps on <u>off</u> (0700)
	Disable trbl beeps on <u>off</u> (0701)
	UL 98 options on <u>off</u> (0702)
	Global fire on <u>off</u> (0703)
	Silent panic on <u>off</u> (0704)
Partition	
	Siren verify on <u>off</u> (0710—Ptn 1 only)
<b>Sensors</b>	
Learn sensors	
	Sensor partition <u>1</u> 2 3 4 5 6
	Sensor group 0
	Trip sensor n
Sensor text	
	Text for sensor n
	Sensor n item 0 0 -
Delete sensors	
	Delete sensor n
	Delete sensor n
Edit sensors	
	Sn P1 Gnn NC/NO/TP
	Sensor partition n
	Sensor group n
<b>Audio verification</b>	
Partition 1	

	Freeze alarm on <u>off</u> (06106 - 06606)
	Freeze temp <u>42</u> (40-90) (06107 - 06607)
	Alarm verify on <u>off</u> (06108 - 06608)
<b>Accessory modules</b>	
Bus Device	
	Unit - ID on <u>off</u> (10000 - 10015)
	Change ID
	Device partitions
	Keypad options
	Energy options
	Outputs
	Cellular options
Snap Cards	
	Device ID nnnnn
	Partition assign <u>1</u> 2 3 4 5 6
	Status beeps <u>on</u> <u>off</u>
	Freeze temp <u>42</u> ° F (40°-90° F)
	Output n
	Cellular system A <u>B</u>
	Key beeps <u>on</u> <u>off</u>
	Temperature 40°-90° F
	Configuration * * * * *
	Output programming
Output programming	
	Output 1
	Output 2
	Output 3
	Output 4
	Partition assign <u>1</u> 2 3 4 5 6 (101100)
	Partition assign <u>1</u> 2 3 4 5 6 (101110)
	Partition assign <u>1</u> 2 3 4 5 6 (101120)
	Partition assign <u>1</u> 2 3 4 5 6 (101130)
	Configuration
	Configuration



Audio verify on <u>off</u> (09000)
Audio mode 1(09001)
Fire shutdown on <u>off</u> (09002)
Silent talkback on <u>off</u> (09003)
Access timeout <u>90 sec</u> (30-300)
Beep delay <u>2 sec</u> (0-300) (09005)
Access code * * * * (09006)
VOX mic gain <u>14</u> (01-64) (09007)
VOX gain range <u>64</u> (01-64) (09008)
Manual mic gain <u>04</u> (cannot change) (09009)
VOX RX gain <u>08</u> (01-10) (09010)

Configuration
Configuration
Output text
Output 1 (10120)
Output 2 (10121)
Output 3 (10122)
Output 4 (10123)
Output 1 Item n
Output 2 item n
Output 3 item n
Output 4 Item n

<b>Onboard options</b>	
Input	
Smoke verify on <u>off</u> (1100)	
2-wire smoke on <u>off</u> (1101)	
Output programming	
Output 1	
Partition assign <u>1 2 3 4 5 6</u> (11100)	
Configuration 01614 (11101)	
Output 2	
Partition assign <u>1 2 3 4 5 6</u> (11110)	
Configuration 01614 (11101)	
Output programming	
Output 1 (1120)	
Output 1 item n	
Output 2 item n	

Table 25. Tier two menus

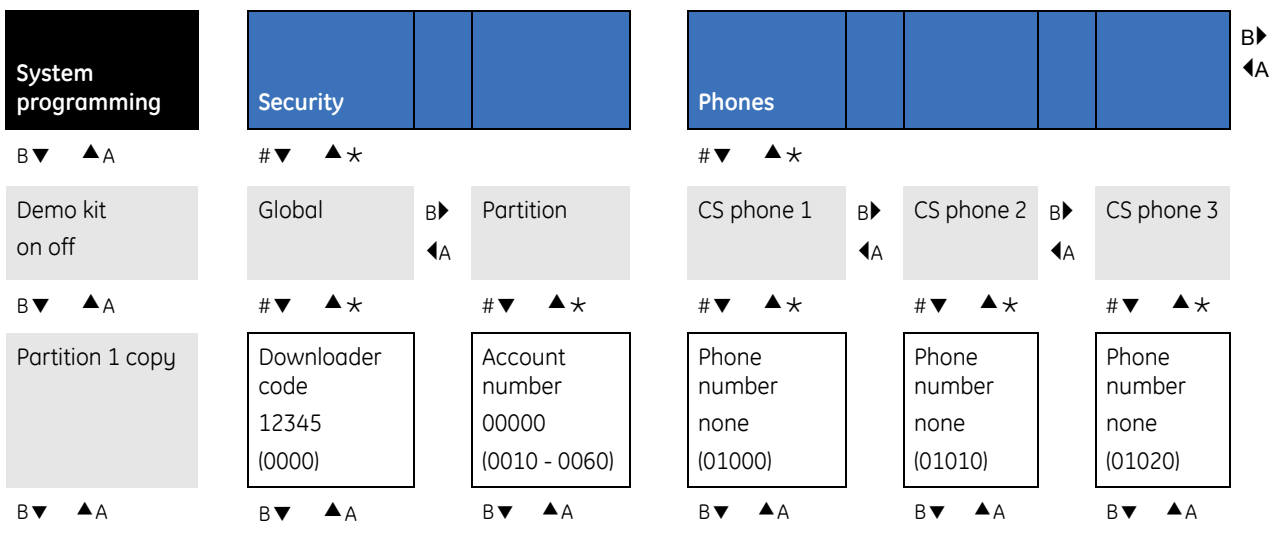

Table 25. Tier two menus

System programming	Security		Phones		
B▼ ▲A	#▼ ▲*★		#▼ ▲*★		
Clear memory	Installer code 4321 (0001)	Quick arm on <u>off</u> (0011 - 0061)	High lvl rpts on <u>off</u> (01001)	High lvl rpts on <u>off</u> (01011)	High lvl rpts on <u>off</u> (01021)
B▼ ▲A	B▼ ▲A	B▼ ▲A	B▼ ▲A	B▼ ▲A	B▼ ▲A
Exit programming	Dealer code **** (0002)	Quick exit on <u>off</u> (0012 - 0062)	Low lvl rpts on <u>off</u> (01002)	Low lvl rpts on <u>off</u> (01012)	Low lvl rpts on <u>off</u> (01022)
#	B▼ ▲A	B▼ ▲A	B▼ ▲A	B▼ ▲A	B▼ ▲A
	Access code lock on <u>off</u> (0003)	Exit extension on <u>off</u> (0013 - 0063)	Exception rpts on <u>off</u> (01003)	Exception rpts on <u>off</u> (01013)	Exception rpts on <u>off</u> (01023)
	B▼ ▲A	B▼ ▲A	B▼ ▲A	B▼ ▲A	B▼ ▲A
	Ptn security on <u>off</u> (0004)	Keyswitch sensor none (0014 - 0064)	Open/close rpts on <u>off</u> (01004)	Open/ close rpts on <u>off</u> (01014)	Open/ close rpts on <u>off</u> (01024)
	B▼ ▲A	B▼ ▲A	B▼ ▲A	B▼ ▲A	B▼ ▲A
	Multi ptn arm none (0005)	Keyswitch style <u>transition</u> state (0015 - 0065)	Backup on <u>off</u> (01005)	Backup on <u>off</u> (01015)	Backup on <u>off</u> (01025)
	B▼ ▲A	B▼ ▲A	B▼ ▲A	B▼ ▲A	B▼ ▲A
	Keychain TP ptn (0006)	Duress code **** (0016 - 0066)	Reporting format SIA <u>CID</u> (01006)	Reporting format SIA <u>CID</u> (01016)	Reporting format SIA <u>CID</u> (01026)
			B▼ ▲A	B▼ ▲A	B▼ ▲A
			Cellular backup on <u>off</u> (01007)	Cellular backup on <u>off</u> (01017)	Cellular backup on <u>off</u> (01027)

B▶  
◀A



**Phones (cont.)** B▶  
◀A

#▼ ▲\*

B▼ ▲A

Ptn assignment  
1 2 3 4 5 6  
(01037)

B▼ ▲A

Ptn assignment  
1 2 3 4 5 6  
(01047)

B▼ ▲A

Ptn assignment  
1 2 3 4 5 6  
(01057)

B▼ ▲A

Ptn assignment  
1 2 3 4 5 6  
(01067)

B▼ ▲A

Ptn assignment  
1 2 3 4 5 6  
(01077)

B▶  
◀A

**Phone options**

#▼ ▲\*

Global

B▶  
◀A

Partition

#▼ ▲\*

Phone test  
on off  
(02000)

B▼ ▲A

Auto phone test  
on off  
(02001)

B▼ ▲A

Auto test reset  
on off  
(02002)

B▼ ▲A

Comm failure  
on off  
(02003)

B▼ ▲A

#▼ ▲\*

Local phone ctrl  
on off  
(0210 - 0260)

B▼ ▲A

Remote access  
on off  
(0211 - 0261)

B▼ ▲A

Ring/hang/ring  
on off  
(0212 - 0262)

B▼ ▲A

Line fail delay  
none (10-240  
sec)  
(0213—Ptn 1  
only)

B▼ ▲A

B▶  
◀A

**Timers**

#▼ ▲\*

Global

B▶  
◀A

Partition

#▼ ▲\*

Supervisory time  
1:00 - 4:00  
(Random) (0300)

B▼ ▲A

RF Tx timeout  
12 hours (2-24)  
(0302)

B▼ ▲A

Phone test freq.  
7 days (1-255)  
(0303)

B▼ ▲A

Next phone test  
7 days (1-255)  
(0304)

B▼ ▲A

#▼ ▲\*

Entry delay  
30 sec (30-240)  
(0310 - 0360)

B▼ ▲A

Exit delay  
60 sec (45-184)  
(0011 - 0061)

B▼ ▲A

Extended delay  
4 min (1-8)  
(0312 - 0362)

B▼ ▲A

Siren timeout  
4 min (1-30)  
(0313 - 0363)

B▼ ▲A

**Light control** B▶  
◀A

#▼ ▲\*

Partition

#▼ ▲\*

Entry lights  
none (3-9)  
(0400 - 0450)

B▼ ▲A

House code  
1B 2C 3D 4E 5F  
6G (0401 - 0451)

**Phone options**

#▼ ▲\*

DTMF dialing <u>on</u> off (02004)	Toll saver <u>on</u> off (0214 - 0264)
Dial abort delay <u>30</u> sec (15-45) (02006)	Phone panic <u>on</u> off (0215 - 0265)
Cancel message <u>on</u> off (02007)	Phone ACC key # * (0216 - 0266)
Pager delay <u>15</u> sec (0-30) (02008)	
Call wait cancel <u>on</u> off (02009)	
Dial tone detect <u>on</u> off (02010)	

**Timers**

#▼ ▲\*

Output trip time <u>4</u> sec (1-12) (0305)	Sleep time <u>22:00</u> (00:00-23:50) (0314 - 0364)
Activity timeout 24 hours (1-42) (0306)	No usage time <u>none</u> (2-255 min) (0315 - 0365)
Daylight saving <u>on</u> off (0307)	

**Light control**

#▼ ▲\*

**Touchpad options**

#▼ ▲\*

Global	Partition
--------	-----------

#▼ ▲\*      #▼ ▲\*

**Reporting**

#▼ ▲\*

Global	Partition
--------	-----------

#▼ ▲\*      #▼ ▲\*

B▶ ◀A Touchpad options			Reporting									
#▼ ▲*			#▼ ▲*									
Latchkey zones none (1-96) (0500)		Fire panic on off (0510 - 0560)	24-hour tamper on off (06000)			Opening reports on off (06100 - 06600)						
	B▼ ▲A		B▼ ▲A			B▼ ▲A						
		Auxiliary panic <u>on</u> off (0511 - 0561)	Antenna tamper on off (06001)			Closing reports on <u>off</u> (06101 - 06601)						
	B▼ ▲A		B▼ ▲A			B▼ ▲A						
		Police panic <u>on</u> off (0512 - 0562)	Buffer control on off (06002)			No activity on <u>off</u> (06102 - 06602)						
	B▼ ▲A		B▼ ▲A			B▼ ▲A						
		Keychain TP arm on <u>off</u> (0513 - 0563)	Back in service <u>on</u> off (06003)			Duress option on <u>off</u> (06103 - 06603)						
	B▼ ▲A		B▼ ▲A			B▼ ▲A						
		Star is no delay on <u>off</u> (0514 - 0564)	Bypass reports on <u>off</u> (06004)			Force armed on <u>off</u> (06104 - 06604)						
	B▼ ▲A		B▼ ▲A			B▼ ▲A						
			Low CPU battery <u>on</u> off (06005)			Latchkey format on <u>off</u> (06105 - 06605)						
	B▼ ▲A		B▼ ▲A			B▼ ▲A						
			Battery restoral on <u>off</u> (06006)			Freeze alarm on <u>off</u> (06106 - 06606)						
	B▼ ▲A		B▼ ▲A			B▼ ▲A						
			Buffer full report on <u>off</u> (06007)			Freeze temp <u>42</u> (40-90) (06107 - 06607)						
	B▼ ▲A		B▼ ▲A			B▼ ▲A						

B▶ Touchpad options ◀A

#▼ ▲\*

Reporting

#▼ ▲\*

Zone restorals  
on off  
(06008)

B▼ ▲A

Alarm verify  
on off  
(06108 - 06608)

B▼ ▲A

Two trip error  
on off  
(06009)

B▼ ▲A

System tamper  
on off  
(06109 - 06609)

B▼ ▲A

TP panic rpt fmt  
on off  
(06010)

B▼ ▲A

Report confirm  
on off  
(06111 - 06611)

AC failure  
on off  
(06011)

B▼ ▲A

Receiver failure  
on off  
(06012)

B▼ ▲

Ground  
fault  
on off  
(06017)

B▼  
▲A

RF low bat rpt  
daily weekly  
(06013)

B▶  
◀A

RF supv rpt  
daily weekly  
(06014)

B▶  
◀A

Swin  
ger  
limit  
1 (1-  
2)  
(060  
15)

B▶  
◀A

Aux  
power  
fail  
on off  
(06016)





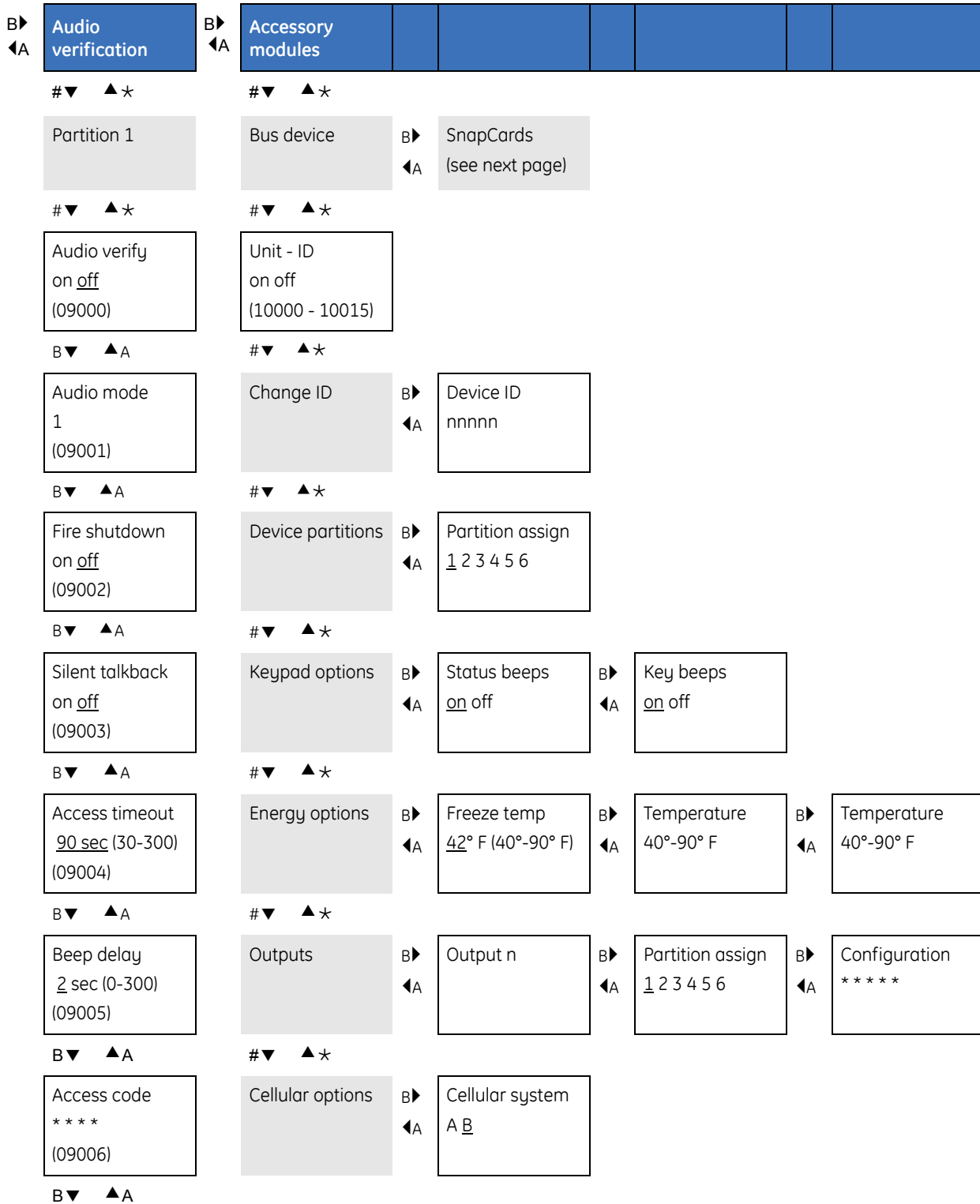

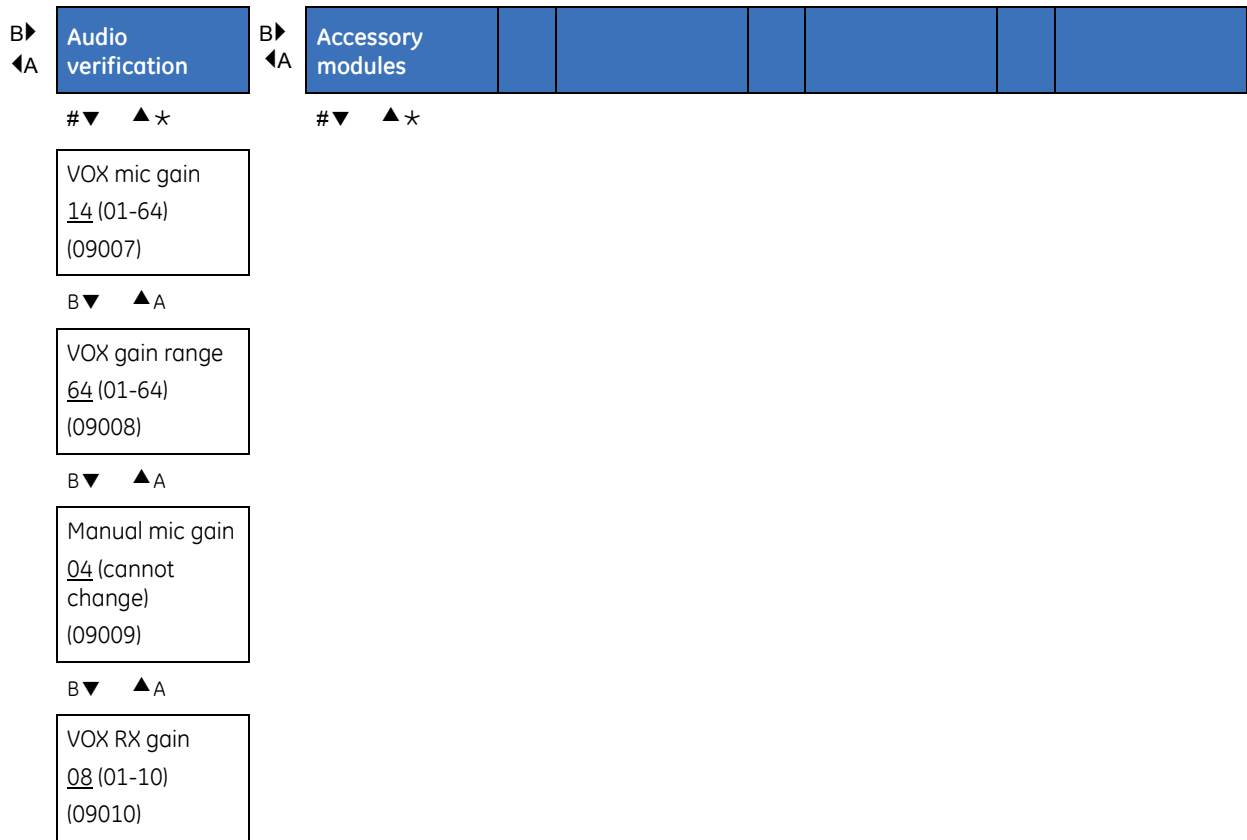

**Accessory modules (cont.)**

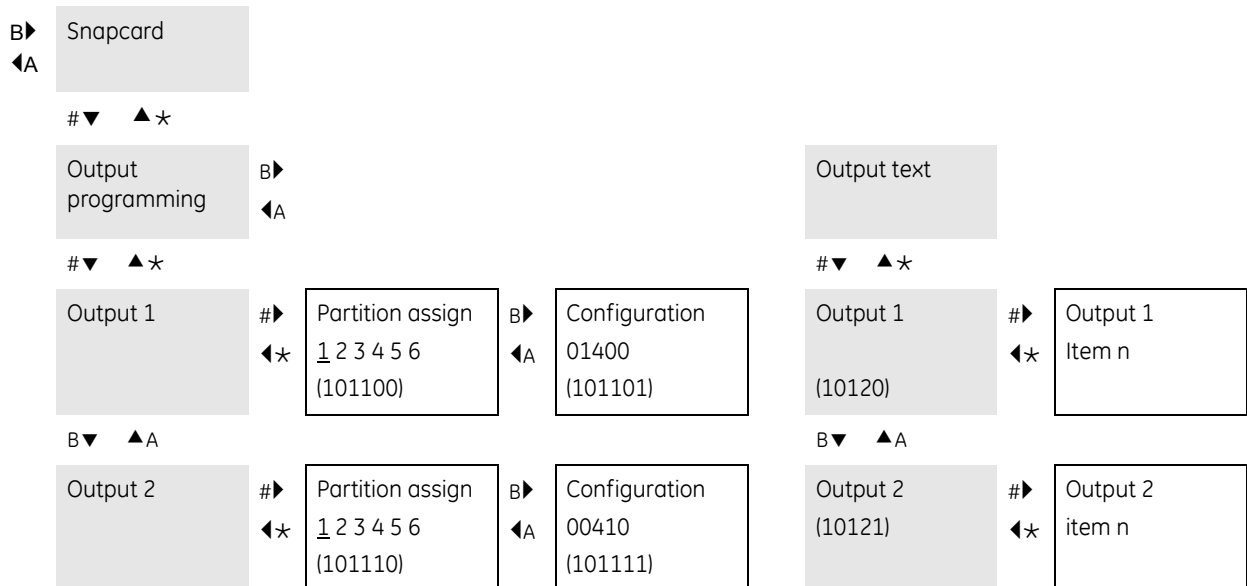

Accessory modules (cont.)

B▼ ▲A

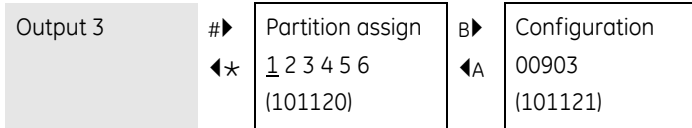

B▼ ▲A

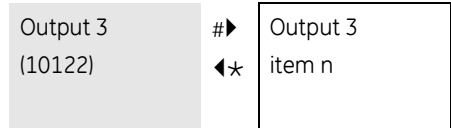

B▼ ▲A

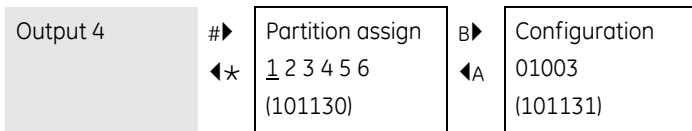

B▼ ▲A

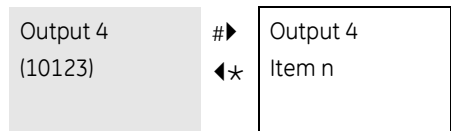

Onboard options

#▼ ▲\*

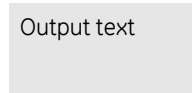
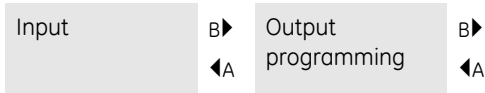

#▼ ▲\*

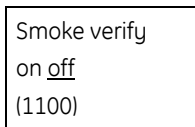

#▼ ▲\*

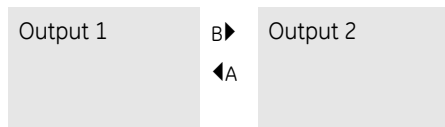

#▼ ▲\*

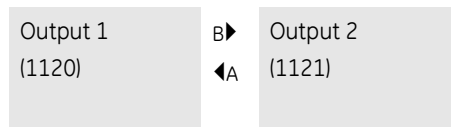

B▼ ▲A

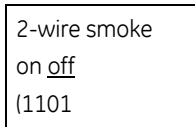

#▼ ▲\*

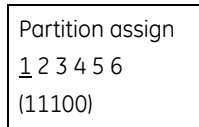

#▼ ▲\*

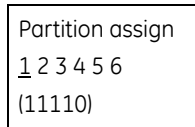

#▼ ▲\*

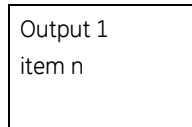

#▼ ▲\*

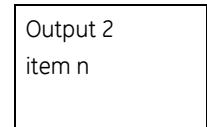

B▼ ▲A

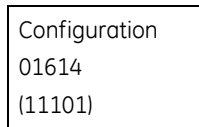

B▼ ▲A

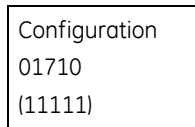



# Appendix C Reference tables

This appendix provides a list of reference tables.

In this appendix:

- Sensor group characteristics* ..... 164
- Cross zoning* ..... 167
- Item number and sensor text* ..... 168
- System event trigger numbers* ..... 169
- System group event trigger numbers* ..... 170
- Sensor number event trigger numbers* ..... 171
- System feature event trigger numbers* ..... 175
- Response characteristics* ..... 176
- Response numbers* ..... 177

## Reference tables

This table shows what the sensors on your Concord 4 system do. Every sensor is assigned to a group, and this table specifies those groups and functions. Every device must be assigned to one of these groups.

Table 25. Sensor group characteristics

No.	Name	Application	Alarm	Delay	Restoral	Supervi sory	CS Report	Chime (Level)	Active levels
00	Fixed panic	24-hour audible fixed emergency buttons.	Police	Instant		✓	✓		1,2,3
01	Portable panic	24-hour audible portable emergency buttons.	Police	Instant			✓		1,2,3
02	Fixed panic	24-hour silent fixed emergency buttons.	Silent	Instant		✓	✓		1,2,3
03	Portable panic	24-hour silent portable emergency buttons.	Silent	Instant			✓		1,2,3
04	Fixed auxiliary	24-hour auxiliary sensor, such as Pendant Panic or holdup button.	Auxiliary	Instant		✓	✓		1,2,3
05	Fixed auxiliary	24-hour auxiliary emergency button. Siren shutoff confirms CS report.	Auxiliary	Instant		✓	✓		1,2,3
06	Portable auxiliary	24-hour portable auxiliary alert button.	Auxiliary	Instant			✓		1,2,3
07	Portable auxiliary	24-hour portable auxiliary button. Siren shutoff confirms CS report.	Auxiliary	Instant			✓		1,2,3
08	Special intrusion	Special belongings, such as gun cabinets and wall safes.	Police	Instant	✓	✓	✓		1,2,3
09	Special intrusion	Special belongings (i.e. gun cabinets and wall safes.)	Police	Standard	✓	✓	✓		1,2,3
10	Entry/exit delay	Entry and exit doors that require a standard delay time.	Police	Standard	✓	✓	✓	✓	2,3
11	Entry/exit delay	Garage doors and entrances that require an extended delay time. *	Police	Extended	✓	✓	✓	✓	2,3
12	Entry/exit delay	Driveway gates and entrances that require a twice extended delay time. *	Police	Twice extended	✓	✓	✓	✓	2,3

Table 25. Sensor group characteristics (continued)

No.	Name	Application	Alarm	Delay	Restoral	Supervi sory	CS Report	Chime (Level)	Active levels
14	Instant interior	Interior doors (Hardwired)	Police	Follower	✓	✓	✓		2,3
15	Instant interior	Interior PIR motion sensors. * (RF wireless)	Police	Follower		✓	✓		2,3
16	Instant interior	Interior doors. (Hardwired)	Police	Follower	✓	✓	✓		3
17	Instant interior	PIR motion sensors *(RF wireless.)	Police	Follower		✓	✓		3
18	Instant interior	Instant interior cross-zone# PIR motion sensors. * †	Police	Follower		✓	✓		3
19	Delayed interior	Interior doors that initiate a delay before going into alarm. *	Police	Interior	✓	✓	✓		3
20	Delayed interior	PIR motion sensors that initiate a delay before going into alarm. *	Police	Standard		✓	✓		3
21	Local instant interior	24-hour local alarm zone protecting anything that opens and closes.	Police	Instant	✓	✓			1,2,3
22	Local delayed interior	Same as group 21, plus activation initiates a delay before going into alarm.	Police	Standard	✓	✓			1,2,3
23	Local instant auxiliary	24-hour local alarm zone protecting anything that opens and closes. ‡	Auxiliary	Instant	✓	✓			1,2,3
24	Local instant auxiliary	24-hour local alarm zone protecting anything that opens and closes. Sirens shut off at restoral. *	Auxiliary	Instant	✓	✓			1,2,3
25	Local special chime	Notify the user when a door is opened. Sounds emit from a local annunciator. *	Special chime	Instant		✓			1,2,3
26	Fire	24-hour fire, rate-of-rise heat, and smoke sensors.	Fire	Instant	✓	✓	✓		1,2,3
27	Output module	Hardwire Output Module (HOM) lamp control or other customer feature. ‡	Silent	Instant	✓	✓			1,2,3
28	Output module	HOM, PIR motion sensor, sound sensor or pressure mat. ‡	Silent	Instant		✓			1,2,3

Table 25. Sensor group characteristics (continued)

No.	Name	Application	Alarm	Delay	Restoral	Supervi sory	CS Report	Chime (Level)	Active levels
29	Auxiliary	Freeze sensor.	Auxiliary	Instant	✓	✓	✓		1,2,3
32	Output module	HOM, PIR motion sensor, sound sensor or pressure mat.‡	Silent	Instant					1,2,3
33	Siren	Wireless siren supervision. ‡	Silent	Instant		✓	✓		1,2,3
34	Gas	Carbon monoxide (CO) gas detectors ‡	Auxiliary	Instant	✓	✓	✓		1,2,3
35	Local instant police (day zone)	Local alarm in levels 1 and 2. Report to CS in level 3.	Police	Instant	✓	✓	✓ (Level 3 only)		1,2,3
38	Auxiliary	Water sensor ‡	Auxiliary	Instant	✓	✓	✓		1,2,3

**Note:** Check marks (✓) represent characteristics present in a group.  
 \* This group is not certified as a primary protection circuit for UL-listed systems and is for supplementary use only.  
 † Sounds instant police siren if two or more sensors are tripped within 4 minutes. Otherwise sensors are followers to delayed sensors. If Alarm Verification is on, group 18 functions like group 17.  
 ‡ This group has not been investigated by UL.  
 § This group is required for UL-listed residential fire alarm applications.



## Cross zoning

*Cross-zoning* (two-trip) refers to two different group 18 sensors that must be tripped within two minutes of each other to report an alarm to the central station. *Figure 29* shows the path of a person walking from the kitchen to the living room. When the person is detected walking through the kitchen, the motion sensor in the kitchen is tripped, sounding a local alarm. If motion is detected by the living room motion sensor within two minutes, an alarm report will be sent to the central station.

Figure 29. Cross-zone diagram

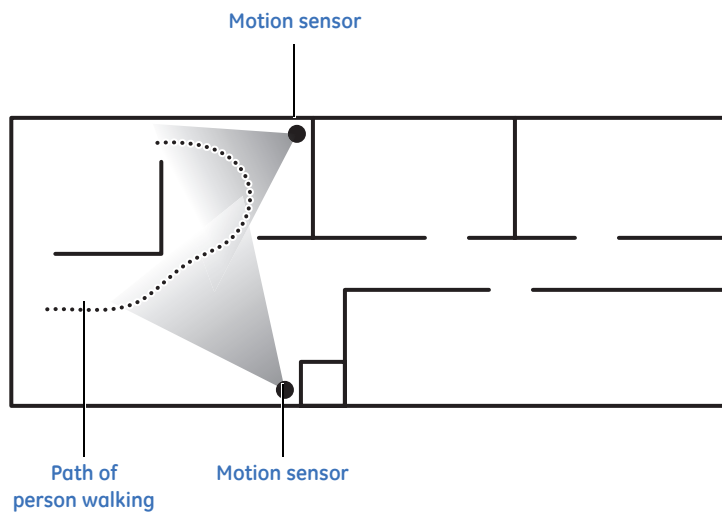

**Note:** We do not recommend cross-zoning for exit/entry zones. Each zone can individually protect the intended area.

Table 26. Item numbers and sensor text

Item #	Sensor text	Item #	Sensor text	Item #	Sensor text	Item #	Sensor text	Item #	Sensor text	Item #	Sensor text
001	Aborted	041	Date	081	Gas	121	North	161	North	201	G
002	AC	042	Daughters	082	Glass	122	Not	162	Not	202	H
003	Access	043	Degrees	083	Goodbye	123	Now	163	Now	203	I
004	Active	044	Delay	084	Hallway	124	Number	164	Number	204	J
005	Activity	045	Den	085	Heat	125	Off	165	Sound	205	K
006	Alarm	046	Desk	086	Hello	126	Office	166	South	206	L
007	All	047	Detector	087	Help	127	OK	167	Special	207	M
008	AM	048	Dining	088	High	128	On	168	Stairs	208	N
009	Area	049	Disarmed	089	Home	129	Open	169	Stay	209	O
010	Arm	050	Door	090	House	130	Opening	170	Supervisory	210	P
011	Armed	051	Down	091	In	131	Panic	171	System	211	Q
012	Arming	052	Download	092	Install	132	Partition	172	Tamper	212	R
013	Attic	053	Downstairs	093	Interior	133	Patio	173	Temperature	213	S
014	Auxilliary	054	Drawer	094	Intrusion	134	Pet	174	Test	214	T
015	Away	055	Driveway	095	Invalid	135	Phone	175	Time	215	U
016	Baby	056	Duct	096	Is	136	Please	176	To	216	V
017	Back	057	Duress	097	Key	137	PM	177	Touchpad	217	W
018	Bar	058	East	098	Kids	138	Police	178	Trouble	218	X
019	Basement	059	Energy Saver	099	Kitchen	139	Pool	179	Unbypass	219	Y
020	Bathroom	060	Enter	100	Latchkey	140	Porch	180	Unit	220	Z
021	Battery	061	Entry	101	Laundry	141	Power	181	Up	221	(space)
022	Bedroom	062	Error	102	Left	142	Press	182	West	222	'(apostrophe)
023	Bottom	063	Exit	103	Level	143	Program	183	Window	223	-(dash)
024	Breezeway	064	Exterior	104	Library	144	Progress	184	Zone	224	_(underscore)
025	Building	065	Factory	105	Light	145	Quiet	185	0	225	*
026	Bus	066	Failure	106	Lights	146	Rear	186	1	226	#
027	Bypass	067	Family	107	Living	147	Receiver	187	2	227	:

Table 26. Item numbers and sensor text

Item #	Sensor text	Item #	Sensor text	Item #	Sensor text	Item #	Sensor text	Item #	Sensor text	Item #	Sensor text
028	Bypassed	068	Father's	108	Load	148	Report	188	3	228	/
029	Cabinet	069	Feature	109	Loading	149	RF	189	4	229	?
030	Canceled	070	Fence	110	Low	150	Right	190	5		?
031	Car	071	Fire	111	Lower	151	Room	191	6		
032	Carbon Monoxide	072	First	112	Main	152	Safe	192	7		
033	Central	073	Floor	113	Master	153	Schedule	193	8		
034	Chime	074	Force	114	Mat	154	Screen	194	9		
035	Closed	075	Foyer	115	Medical	155	Second	195	A		
036	Closet	076	Freeze	116	Memory	156	Sensor	196	B		
037	Closing	077	Front	117	Menu	157	Service	197	C		
038	Code	078	Furnace	118	Mother's	158	Shed	198	D		
039	Computer	079	Gallery	119	Motion	159	Shock	199	E		
040	Control	080	Garage	120	No	160	Side	200	F		

Table 27. System event trigger numbers

System event	Description	Trigger no.
Null trigger (used for direct control)	Activates only by schedule or direct command.	000
Fire alarm	When fire sirens are started.	001
Police alarm	When police sirens are started.	002
Auxiliary alarm	When auxiliary sirens are started.	003
Any audible alarm	When any of the above sirens are started.	004
Silent alarm (sensor groups 2, 3, and duress)	When a group 2 or 3 sensor goes into alarm or when a duress alarm is activated (does not include groups 25, 27, 28, or 32).	005
Any audible or silent alarm	When any alarm is started (does not include groups 25, 27, 28, or 32).	006
HOM group 27, 28, 32 in alarm	When a sensor in group 27, 28, or 32 goes into alarm.	007
Major trouble (phone or receiver failure)	When a receiver failure (S94) or a phone failure (S96) occurs.	008
Arming to STAY or AWAY	When the system is armed to level 2 or 3.	009
Arming to AWAY	When the system is armed to level 3.	010

Table 27. System event trigger numbers

System event	Description	Trigger no.
AVM is interactive (audio session in progress)	When the central station operator begins listening or talking to the premises.	011
Fail-to-communicate (panel can't call CS or pager)	When the fail-to-communicate output is activated.	012
AVM trip (edge)	When an AVM alarm occurs, output is activated momentarily.	013
Keychain touchpad star button-press	When the star button on a keychain touchpad is pressed.	014
Smoke power (for resetting 4-wire smoke detectors)	Deactivated when hardwire smoke detectors need to be reset.	015
Exterior siren	Activated for police or fire alarms.	016
Interior siren	Activation follows all system noises	017
AVM trip (pulse)	When an AVM alarm occurs, output is deactivated for 10 ms	018
State of system status	Follows the state of system status (ready or trouble).	019
Tamper condition	When any tamper is tripped	020
Closing report sent	When a closing report has been successfully transmitted to the central station.	021
Arming to level 1	When the system is disarmed.	022
Group XX in alarm	When any sensor in group XX goes into alarm	
Sensor XX in alarm	When sensor number XX goes into alarm	
Sensor XX open	When sensor number XX is opened	

Table 28. Sensor group event trigger numbers

Sensor group	Trigger no.	Sensor group	Trigger no.
Group 00 in alarm	064	Group 17 in alarm	081
Group 01 in alarm	065	Group 18 in alarm	082
Group 02 in alarm	066	Group 19 in alarm	083
Group 03 in alarm	067	Group 20 in alarm	084
Group 04 in alarm	068	Group 21 in alarm	085
Group 05 in alarm	069	Group 22 in alarm	086
Group 06 in alarm	070	Group 23 in alarm	087
Group 07 in alarm	071	Group 24 in alarm	088
Group 08 in alarm	072	Group 25 in alarm	089

Table 28. Sensor group event trigger numbers

Sensor group	Trigger no.	Sensor group	Trigger no.
Group 09 in alarm	073	Group 26 in alarm	090
Group 10 in alarm	074	Group 27 in alarm	091
Group 11 in alarm	075	Group 28 in alarm	092
Group 12 in alarm	076	Group 29 in alarm	093
Group 13 in alarm	077	Group 30 in alarm	094
Group 14 in alarm	078	Group 31 in alarm	095
Group 15 in alarm	079	Group 32 in alarm	096
Group 16 in alarm	080	Group 35 in alarm	102

Table 29. Sensor number event trigger numbers

Sensor Number	State	Trigger no.	State	Trigger no.
Sensor 01	in alarm	129	open	257
Sensor 02	in alarm	130	open	258
Sensor 03	in alarm	131	open	259
Sensor 04	in alarm	132	open	260
Sensor 05	in alarm	133	open	261
Sensor 06	in alarm	134	open	262
Sensor 07	in alarm	135	open	263
Sensor 08	in alarm	136	open	264
Sensor 09	in alarm	137	open	265
Sensor 10	in alarm	138	open	266
Sensor 11	in alarm	139	open	267
Sensor 12	in alarm	140	open	268
Sensor 13	in alarm	141	open	269
Sensor 14	in alarm	142	open	270
Sensor 15	in alarm	143	open	271
Sensor 16	in alarm	144	open	272
Sensor 17	in alarm	145	open	273
Sensor 18	in alarm	146	open	274
Sensor 19	in alarm	147	open	275

Table 29. Sensor number event trigger numbers

Sensor Number	State	Trigger no.	State	Trigger no.
Sensor 20	in alarm	148	open	276
Sensor 21	in alarm	149	open	277
Sensor 22	in alarm	150	open	278
Sensor 23	in alarm	151	open	279
Sensor 24	in alarm	152	open	280
Sensor 25	in alarm	153	open	281
Sensor 26	in alarm	154	open	282
Sensor 27	in alarm	155	open	283
Sensor 28	in alarm	156	open	284
Sensor 29	in alarm	157	open	285
Sensor 30	in alarm	158	open	286
Sensor 31	in alarm	159	open	287
Sensor 32	in alarm	160	open	288
Sensor 33	in alarm	161	open	289
Sensor 34	in alarm	162	open	290
Sensor 35	in alarm	163	open	291
Sensor 36	in alarm	164	open	292
Sensor 37	in alarm	165	open	293
Sensor 38	in alarm	166	open	294
Sensor 39	in alarm	167	open	295
Sensor 40	in alarm	168	open	296
Sensor 41	in alarm	169	open	297
Sensor 42	in alarm	170	open	298
Sensor 43	in alarm	171	open	299
Sensor 44	in alarm	172	open	300
Sensor 45	in alarm	173	open	301
Sensor 46	in alarm	174	open	302
Sensor 47	in alarm	175	open	303
Sensor 48	in alarm	176	open	304
Sensor 49	in alarm	177	open	305
Sensor 50	in alarm	178	open	306

Table 29. Sensor number event trigger numbers

Sensor Number	State	Trigger no.	State	Trigger no.
Sensor 51	in alarm	179	open	307
Sensor 52	in alarm	180	open	308
Sensor 53	in alarm	181	open	309
Sensor 54	in alarm	182	open	310
Sensor 55	in alarm	183	open	311
Sensor 56	in alarm	184	open	312
Sensor 57	in alarm	185	open	313
Sensor 58	in alarm	186	open	314
Sensor 59	in alarm	187	open	315
Sensor 60	in alarm	188	open	316
Sensor 61	in alarm	189	open	317
Sensor 62	in alarm	190	open	318
Sensor 63	in alarm	191	open	319
Sensor 64	in alarm	192	open	320
Sensor 65	in alarm	193	open	321
Sensor 66	in alarm	194	open	322
Sensor 67	in alarm	195	open	323
Sensor 68	in alarm	196	open	324
Sensor 69	in alarm	197	open	325
Sensor 70	in alarm	198	open	326
Sensor 71	in alarm	199	open	327
Sensor 72	in alarm	200	open	328
Sensor 73	in alarm	201	open	329
Sensor 74	in alarm	202	open	330
Sensor 75	in alarm	203	open	331
Sensor 76	in alarm	204	open	332
Sensor 77	in alarm	205	open	333
Sensor 78	in alarm	206	open	334
Sensor 79	in alarm	207	open	335
Sensor 80	in alarm	208	open	336
Sensor 81	in alarm	209	open	337

Table 29. Sensor number event trigger numbers

Sensor Number	State	Trigger no.	State	Trigger no.
Sensor 82	in alarm	210	open	338
Sensor 83	in alarm	211	open	339
Sensor 84	in alarm	212	open	340
Sensor 85	in alarm	213	open	341
Sensor 86	in alarm	214	open	342
Sensor 87	in alarm	215	open	343
Sensor 88	in alarm	216	open	344
Sensor 89	in alarm	217	open	345
Sensor 90	in alarm	218	open	346
Sensor 91	in alarm	219	open	347
Sensor 92	in alarm	220	open	348
Sensor 93	in alarm	221	open	349
Sensor 94	in alarm	222	open	350
Sensor 95	in alarm	223	open	351
Sensor 96	in alarm	224	open	352



Table 30. System feature event trigger numbers

Feature	State	Trigger no.
Phone test	initiated	225
AC failure	for 15 minutes	226
CPU low battery	detected (excluding first minute after power-up)	227
Auto phone test	begun	228
Receiver failure	detected	229
Back in service	alarm (AC loss, battery drain, then AC restore)	230
Phone failure	detected	231
Buffer full	detected	232
Two trip error	detected	233
System tamper	alarm (40 incorrect code entry keystrokes)	237
Freeze	alarm	238
No activity	alarm	239
Fire panic	alarm	240
Police panic	alarm	241
Auxiliary panic	alarm	242
Opening report	occurred	243
Closing report	occurred	244
Latchkey opening or closing	occurred	245
Duress	alarm	246
Forced armed report	occurred	247
Fire in partition	alarm	248
Recent closing report	occurred	249
Sensor test	entered	251

Table 31. Response characteristics

Response characteristics	Description
Momentary trip time	The point remains active for nn seconds (n is 1-12 seconds). The default is 4 seconds.
3 minute trip time	The point remains active for three minutes.
Siren-time trip time	The point remains active while the sirens are sounding.
Sustained trip time	The point remains active for the duration of the event.
Siren pattern	The point activates and deactivates according to the current alarm type: <i>Auxiliary: fast on/off/on</i> <i>Police: constant on</i> <i>Fire: repeating</i>
Trip delay	The point activates 30 seconds after the trigger event occurs.

Table 32. Response numbers

Siren tracking	Trip delay	Response time	Response no.
no	no	momentary	00
no	no	3 minutes <sup>5</sup>	01
no	no	siren time <sup>2</sup>	02
no	no	sustained <sup>3</sup>	03
no	yes <sup>4</sup>	momentary	04
no	yes <sup>4</sup>	3 minutes <sup>5</sup>	05
no	yes <sup>4</sup>	siren time <sup>2</sup>	06
no	yes <sup>4</sup>	sustained <sup>3</sup>	07
yes <sup>1</sup>	no	momentary	08
yes <sup>1</sup>	no	3 minutes <sup>5</sup>	09
yes <sup>1</sup>	no	siren time <sup>2</sup>	10
yes <sup>1</sup>	no	sustained <sup>3</sup>	11
yes <sup>1</sup>	yes <sup>4</sup>	momentary	12
yes <sup>1</sup>	yes <sup>4</sup>	3 minutes <sup>5</sup>	13
yes <sup>1</sup>	yes <sup>4</sup>	siren time <sup>2</sup>	14
yes <sup>1</sup>	yes <sup>4</sup>	sustained <sup>3</sup>	15

### Notes for response numbers

The mechanical lifetime of the relay may be exceeded if an output is set up for a siren tracking response and a pulsing siren (auxiliary or fire) is active for long time periods. A SnapCard relay output's lifetime expectancy is about 350 total pulsing hours.

- If an event does not trigger sirens, siren tracking response numbers activate without turning on the output. If sirens are triggered by another event, the output pulses to match the siren. If the siren cadence changes (from police to fire, for example), outputs set up for siren tracking change to match the siren and all pulsing outputs pulse to one common cadence.
- If an event does not trigger sirens, siren time response times activate outputs only if sirens are active for another reason.
- If an alarm event does not necessarily require disarming (no activity, closing report, etc.), outputs set up for a sustained response time remain activated until the next arming level change.
- If an event occurs that activates an output set up for trip delay, the delay and output activation can be canceled by trigger event restoral.

**Note:** The trip delay is factory set for 30 seconds and cannot be changed.

Activated outputs set up for a 3-minute response time remain active for the entire three minutes. To deactivate the output before the 3-minute time expires, you must enter program mode or remove panel power. Activated outputs set up for a momentary or 3-minute response time restart if the same trigger event occurs again.



# Appendix C Hardware

This appendix provides specification requirements as well as system wiring notes.

In this appendix:

<i>Specifications</i> .....	180
<i>System wiring notes</i> .....	181

## Specifications

**Power Requirements:** Class 2, 16.5 VAC, 40 VA, 60 Hz (part no. 600-1023 or 600-1024)

Rechargeable Batteries: 12 VDC, 4.5 or 5.0Ah Lead-Acid (part no. 60-681) OR 12 VDC, 7Ah (part no. 60-680). The battery will last 24 hours with no AC and specified standby load

**Radio Frequency:** 319.5 MHz

**Nominal RF Range:** 1,000 feet (305 meters) typical open air

**Storage Temperature Range:** -30° to 140° F (-34° to 60° C)

**Operating Temperature Range:** 32° to 120° F (0° to 49° C)

**Maximum Humidity:** 85% Relative Humidity (non-condensing)

**Auxiliary Power Output:** 1.0 A @ 9 to 14 VDC (12 VDC typical)

**Dimensions:** 14 in. (35.6 cm) x 12 in. (30.5 cm) x 3.0 in. (7.6 cm) (H x W x D)

Figure 29. System diagram

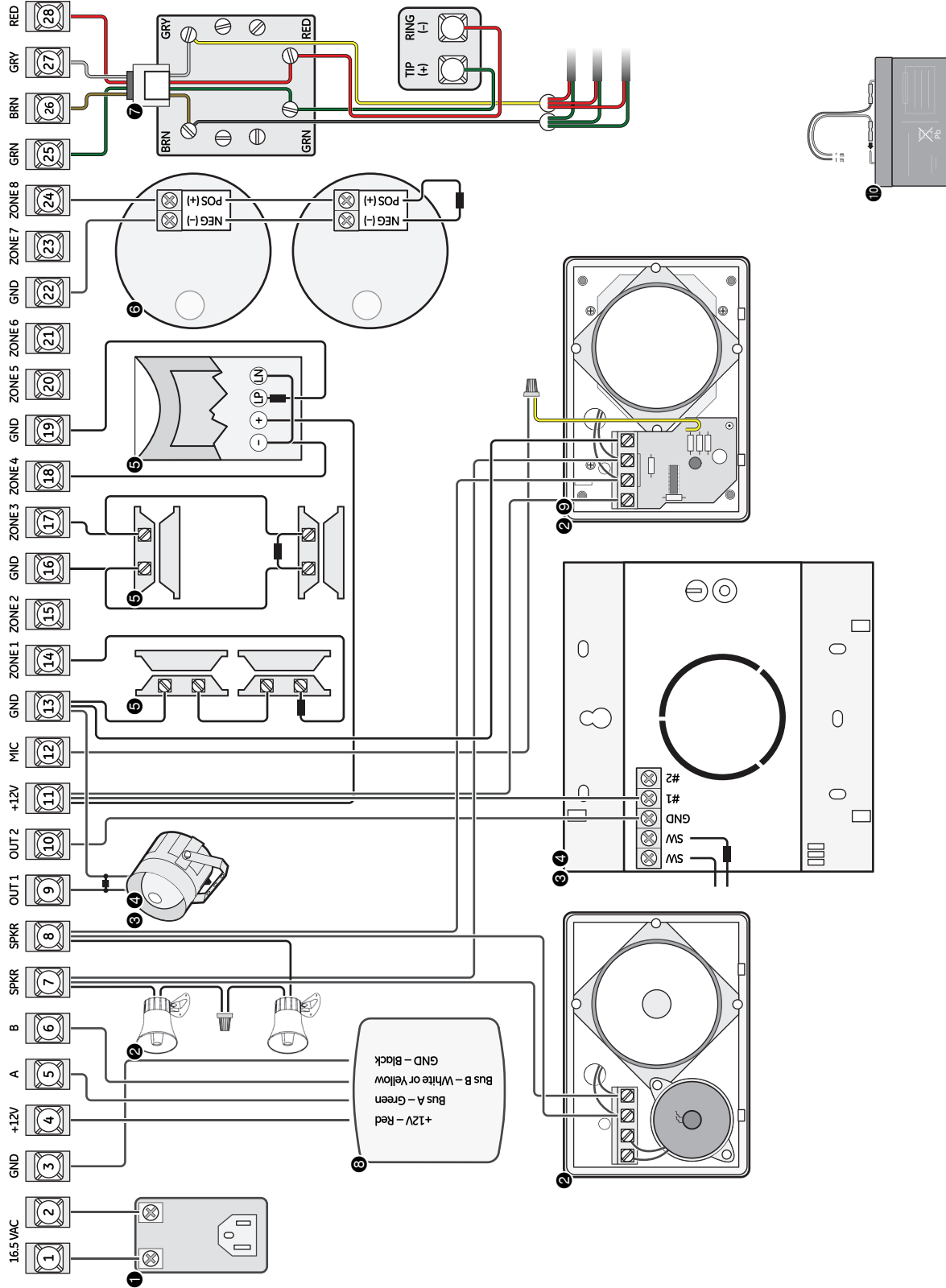
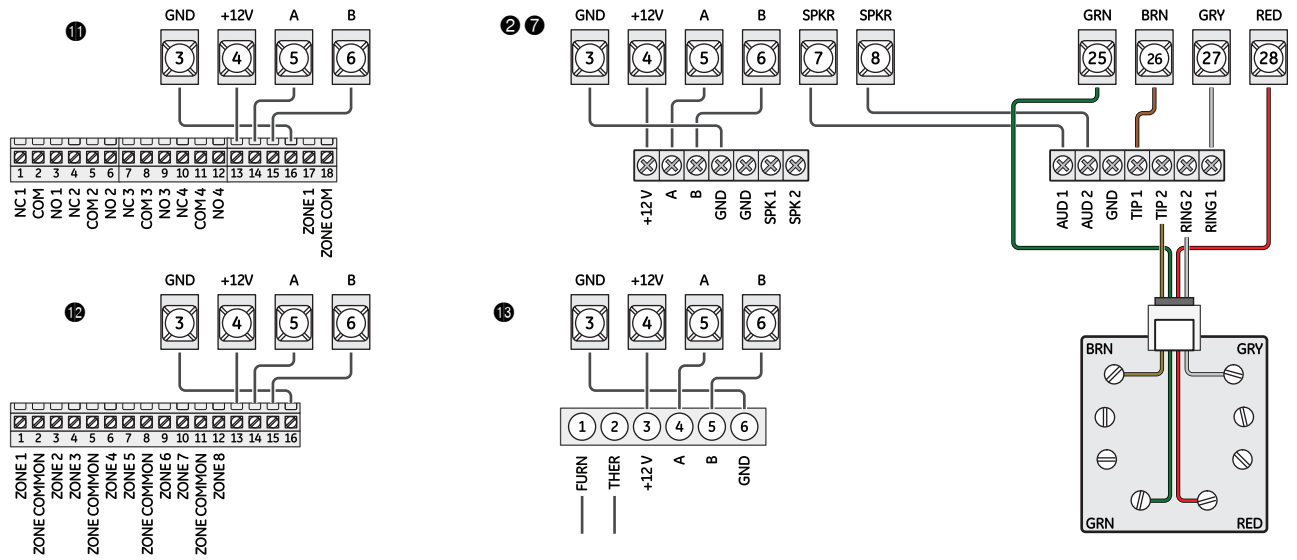

Figure 30. Other SuperBus 2000 module connections





## System wiring notes

Table 33 explains the various component functionality as shown in *Figure 29* on page 165 and *Figure 30* on page 166.

Table 26. System wiring notes

- ❶ Class 2 power transformer must be plugged into an unswitched AC power receptacle. Do not short the transformer terminals together. The transformer contains an internal fuse that permanently disables the output if the terminals are shorted.
- ❷ Speaker terminals 7 and 8 activate for Partition 1 alarms only. Use speakers with 8 ohm or higher impedance. Use 18 ga. stranded wire. When connecting two or more 8 ohm speakers, wire them in series as shown. Wiring speakers in parallel can permanently damage the panel.
- ❸ Output 1 is +12 V switched, rated for 1 A maximum. Default configuration number 01614 activates output 30 seconds after a fire or intrusion alarm occurs. Output 2 is open-collector type rated for 300 mA maximum. Default configuration number 01710 activates output for status and alarm sounds. Refer to panel installation instructions for all possible settings. The total current sourced from terminals 4, 7, 8, 9, 11, 24, and all snapcard terminals (if used) is limited to 1.0 A maximum.
- ❹ Connect multiple piezo sirens in parallel.
- ❺ Zone (loop) wiring shown is an example that applies to all zones (except when zone 8 is configured for 2-wire smoke detectors). Install EOL resistors across all unused zone (loop) inputs.
- ❻ For UL listed installations, wire multiple supervised 2-wire hardwired smoke detectors (20 maximum) only as shown. Maximum 120  $\mu$ A current draw per detector. Maximum 90 mA current draw in alarm.
- ❼ Some telephones are polarity-sensitive. Green and red wires may need to be reversed.
- ❽ SuperBus 2000 alphanumeric touchpads required for onsite programming (models 60-746-01, 60-803, 60-804, 60-983, 60-984, or 60-985). For normal operation and programming, a SuperBus 2000 fixed display touchpad (60-820) or SuperBus 2000 FTP 1000 touchpad may be used. Maximum 16 bus devices per panel (all partitions).
- ❾ A maximum of two audio verification modules (60-677) are allowed (Partition 1 only). Wire multiple speakers in series; power and microphone wires in parallel. Use shielded cable to prevent crosstalk between the speaker and microphone. Audio verification modules shall not be used in UL listed installations.
- ❿ Use 60-681 (12 VDC, 4.5 or 5 Ah) or 60-680 (12 VDC, 7 Ah) backup battery. Battery is automatically tested every 24 hours (every 4 hours with UL 98 options set on). Replace only with exact replacement. Without AC power, panel will shut down if battery voltage falls below 10.2 VDC.
- ⓫ Refer to the *SuperBus 2000 4-Relay Output Module Installation Instructions* for device connections to module outputs.
- ⓬ Refer to the *SuperBus 2000 Energy Saver Module Installation Instructions* for thermostat wiring details.
- ⓭ Connect hardwired zones to module inputs the same as those shown for the panel. Install EOL resistors across all unused zone inputs. Refer to the *SuperBus 2000 8Z Module Installation Instructions* for complete details.



## Index

<b>A</b>		<b>L</b>	
AC power transformer.....	36	Light control.....	121
access code.....	127	<b>M</b>	
antenna shrouds.....	18	macro keys menu.....	102
Arming and disarming.....	127	menu.....	53
Audio verification.....	89	Menu navigation.....	42
Audio verification module.....	123	Mounting.....	16
<b>B</b>		<b>N</b>	
Bypassing.....	128	numbers.....	45
<b>C</b>		<b>O</b>	
California State Fire Marshall listed installations.....	7	onboard options - inputs settings.....	99
Cellular backup.....	124	onboard options - output text settings.....	101
central.....	53	onboard options menu.....	99
Central station/pager communication.....	119	options.....	83, 99
Connecting speakers		output.....	100, 101
<i>Hardwire interior speaker</i> .....	22	Outputs and sirens.....	121
conventions.....	vii	<b>P</b>	
<b>D</b>		pager.....	56
DB-8 cord.....	35	panel.....	8
Demo kit mode.....	43	panel components.....	17
<b>E</b>		panel location.....	13
Energy saver module (ESM).....	122	Panel power.....	126
enu.....	46	Partition.....	84
<b>G</b>		partition.....	50
global.....	46, 65	Phone communication.....	119
Grounding.....	17	Phones.....	53
<b>H</b>		Phones menu.....	53
Hardwire zone issues.....	130	Planning the installation.....	8
<b>I</b>		Power.....	37
Installation.....	12	preface.....	vii
<b>K</b>		programming.....	103
keys.....	102	<i>system programming menu</i> .....	43
		programming menus.....	45
		Programming mode.....	40
		publication library.....	133
		<b>Q</b>	
		quick programming mode.....	103

## R

Reporting menu .....	73
Response Numbers .....	173
RJ 31X phone jack .....	34

## S

safety terms and symbols .....	vii
Security menu	
<i>global settings</i> .....	46
Sensors .....	85
Sensors menu .....	85
sensors menu .....	85
Siren issues .....	129
siren options .....	83
Siren options menu .....	83
SnapCards .....	18
Speaker issues .....	129
speakers .....	22
Streamlining .....	119
SuperBus 2000 .....	9
system power and wire length guidelines .....	13
system programming menu .....	43
System version menu .....	114

## T

technical support .....	133
Touchpad display contrast .....	122
Touchpad options menu .....	71
Touchpad programming options .....	41
troubleshooting .....	126

## U

UL Canada listed installations .....	6
--------------------------------------	---

## W

Wireless touchpad issues .....	131
--------------------------------	-----

## Z

Zone inputs .....	19
Zones/sensors .....	118

## Numerics

2-wire smoke detectors .....	19
4-wire smoke detectors .....	21