

Analog Fire Panel AFP-200

Installation Manual

Document 15511	H2
10/14/2002 Rev:	
15511:H2 ECN 02-436	

Fire Alarm System Limitations

While a fire alarm system may lower insurance rates, it is not a substitute for fire insurance!

An automatic fire alarm system—typically made up of smoke detectors, heat detectors, manual pull stations, audible warning devices, and a fire alarm control with remote notification capability—can provide early warning of a developing fire. Such a system, however, does not assure protection against property damage or loss of life resulting from a fire.

The Manufacturer recommends that smoke and/or heat detectors be located throughout a protected premise following the recommendations of the current edition of the National Fire Protection Association Standard 72 (NFPA 72), manufacturer's recommendations, State and local codes, and the recommendations contained in the Guide for Proper Use of System Smoke Detectors, which is made available at no charge to all installing dealers. A study by the Federal Emergency Management Agency (an agency of the United States government) indicated that smoke detectors may not go off in as many as 35% of all fires. While fire alarm systems are designed to provide early warning against fire, they do not guarantee warning or protection against fire. A fire alarm system may not provide timely or adequate warning, or simply may not function, for a variety of reasons:

Smoke detectors may not sense fire where smoke cannot reach the detectors such as in chimneys, in or behind walls, on roofs, or on the other side of closed doors. Smoke detectors also may not sense a fire on another level or floor of a building. A second-floor detector, for example, may not sense a first-floor or basement fire.

Particles of combustion or "smoke" from a developing fire may not reach the sensing chambers of smoke detectors because:

- Barriers such as closed or partially closed doors, walls, or chimneys may inhibit particle or smoke flow.
- Smoke particles may become "cold," stratify, and not reach the ceiling or upper walls where detectors are located.
- Smoke particles may be blown away from detectors by air outlets.
- Smoke particles may be drawn into air returns before reaching the detector.

The amount of "smoke" present may be insufficient to alarm smoke detectors. Smoke detectors are designed to alarm at various levels of smoke density. If such density levels are not created by a developing fire at the location of detectors, the detectors will not go into alarm.

Smoke detectors, even when working properly, have sensing limitations. Detectors that have photoelectronic sensing chambers tend to detect smoldering fires better than flaming fires, which have little visible smoke. Detectors that have ionizing-type sensing chambers tend to detect fast-flaming fires better than smoldering fires. Because fires develop in different ways and are often unpredictable in their growth, neither type of detector is necessarily best and a given type of detector may not provide adequate warning of a fire.

Smoke detectors cannot be expected to provide adequate warning of fires caused by arson, children playing with matches (especially in bedrooms), smoking in bed, and violent explosions (caused by escaping gas, improper storage of flammable materials, etc.).

Heat detectors do not sense particles of combustion and alarm only when heat on their sensors increases at a predetermined rate or reaches a predetermined level. Rate-of-rise heat detectors may be subject to reduced sensitivity over time. For this reason, the rate-of-rise feature of each detector should be tested at least once per year by a qualified fire protection specialist. Heat detectors are designed to protect property, not life.

IMPORTANT! Smoke detectors must be installed in the same room as the control panel and in rooms used by the system for the connection of alarm transmission wiring, communications, signaling, and/or power. If detectors are not so located, a developing fire may damage the alarm system, crippling its ability to report a fire.

Audible warning devices such as bells may not alert people if these devices are located on the other side of closed or partly open doors or are located on another floor of a building. Any warning device may fail to alert people with a disability or those who have recently consumed drugs, alcohol or medication. Please note that:

- Strobes can, under certain circumstances, cause seizures in people with conditions such as epilepsy.
- Studies have shown that certain people, even when they hear a fire alarm signal, do not respond or comprehend the meaning of the signal. It is the property owner's responsibility to conduct fire drills and other training exercise to make people aware of fire alarm signals and instruct them on the proper reaction to alarm signals.
- In rare instances, the sounding of a warning device can cause temporary or permanent hearing loss.

A fire alarm system will not operate without any electrical power. If AC power fails, the system will operate from standby batteries only for a specified time and only if the batteries have been properly maintained and replaced regularly.

Equipment used in the system may not be technically compatible with the control. It is essential to use only equipment listed for service with your control panel.

Telephone lines needed to transmit alarm signals from a premise to a central monitoring station may be out of service or temporarily disabled. For added protection against telephone line failure, backup radio transmission systems are recommended.

The most common cause of fire alarm malfunction is inadequate maintenance. To keep the entire fire alarm system in excellent working order, ongoing maintenance is required per the manufacturer's recommendations, and UL and NFPA standards. At a minimum, the requirements of Chapter 7 of NFPA 72 shall be followed. Environments with large amounts of dust, dirt or high air velocity require more frequent maintenance. A maintenance agreement should be arranged through the local manufacturer's representative. Maintenance should be scheduled monthly or as required by National and/or local fire codes and should be performed by authorized professional fire alarm installers only. Adequate written records of all inspections should be kept.

Precau-L-4-2002.fm

Installation Precautions

Adherence to the following will aid in problem-free installation with long-term reliability:

WARNING - Several different sources of power can be connected to the fire alarm control panel. Disconnect all sources of power before servicing. Control unit and associated equipment may be damaged by removing and/or inserting cards, modules, or interconnecting cables while the unit is energized. Do not attempt to install, service, or operate this unit until this manual is read and understood.

CAUTION - System Reacceptance Test after Software Changes. To ensure proper system operation, this product must be tested in accordance with NFPA 72 Chapter 7 after any programming operation or change in site-specific software. Reacceptance testing is required after any change, addition or deletion of system components, or after any modification, repair or adjustment to system hardware or wiring.

All components, circuits, system operations, or software functions known to be affected by a change must be 100% tested. In addition, to ensure that other operations are not inadvertently affected, at least 10% of initiating devices that are not directly affected by the change, up to a maximum of 50 devices, must also be tested and proper system operation verified.

This system meets NFPA requirements for operation at 0-49° C/32-120° F and at a relative humidity of 85% RH - 93% per ULC - (non-condensing) at 30° C/86° F. However, the useful life of the system's standby batteries and the electronic components may be adversely affected by extreme temperature ranges and humidity. Therefore, it is recommended that this system and all peripherals be installed in an environment with a nominal room temperature of 15-27° C/60-80° F.

Verify that wire sizes are adequate for all initiating and indicating device loops. Most devices cannot tolerate more than a 10% I.R. drop from the specified device voltage.

Like all solid state electronic devices, this system may operate erratically or can be damaged when subjected to lightning-induced transients. Although no system is completely immune from lightning transients and interferences, proper grounding will reduce susceptibility. Overhead or outside aerial wiring is not recommended, due to an increased susceptibility to nearby lightning strikes. Consult with the Technical Services Department if any problems are anticipated or encountered.

Disconnect AC power and batteries prior to removing or inserting circuit boards. Failure to do so can damage circuits.

Remove all electronic assemblies prior to any drilling, filing, reaming, or punching of the enclosure. When possible, make all cable entries from the sides or rear. Before making modifications, verify that they will not interfere with battery, transformer, and printed circuit board location.

Do not tighten screw terminals more than 9 in-lbs. Over-tightening may damage threads, resulting in reduced terminal contact pressure and difficulty with screw terminal removal.

Though designed to last many years, system components can fail at any time. This system contains static-sensitive components. Always ground yourself with a proper wrist strap before handling any circuits so that static charges are removed from the body. Use static-suppressive packaging to protect electronic assemblies removed from the unit.

Follow the instructions in the installation, operating, and programming manuals. These instructions must be followed to avoid damage to the control panel and associated equipment. FACP operation and reliability depend upon proper installation by authorized personnel.

FCC Warning

WARNING: This equipment generates, uses, and can radiate radio frequency energy and if not installed and used in accordance with the instruction manual, may cause interference to radio communications. It has been tested and found to comply with the limits for class A computing device pursuant to Subpart B of Part 15 of FCC Rules, which is designed to provide reasonable protection against such interference when operated in a commercial environment. Operation of this equipment in a residential area is likely to cause interference, in which case the user will be required to correct the interference at his own expense.

Canadian Requirements

This digital apparatus does not exceed the Class A limits for radiation noise emissions from digital apparatus set out in the Radio Interference Regulations of the Canadian Department of Communications.

Le present appareil numerique n'emet pas de bruits radio-electriques depassant les limites applicables aux appareils numeriques de la classe A prescrites dans le Reglement sur le brouillage radioelectrique edicte par le ministere des Communications du Canada.

Precau-L-4-2002.fm

Acclimate Plus™, HARSH™, NOTI•FIRE•NET™, ONYX™, and VeriFire™ are trademarks, and **FlashScan®** and **VIEW®** are registered trademarks of NOTIFIER. **NION™** and **UniNet™** are trademarks of NIS. **NIS™** and **Notifier Integrated Systems™** are trademarks and **NOTIFIER®** is a registered trademark of Fire-Lite Alarms, Inc. **Echelon®** is a registered trademark and **LonWorks™** is a trademark of Echelon Corporation. **ARCNET®** is a registered trademark of Datapoint Corporation. **Microsoft®** and **Windows®** are registered trademarks of the Microsoft Corporation. **LEXAN®** is a registered trademark of GE Plastics, a subsidiary of General Electric Company.

About This Manual	10
Section 1 System Overview	14
1.1 General Description	14
1.2 Features	14
1.3 Components	15
1.3.1 Membrane Switch Panel	15
1.3.2 Panel Sounder	16
1.3.3 Output Circuits (TB2)	16
1.3.4 Relays (TB3)	16
1.4 Main Assemblies	17
1.4.1 CPU Board	17
1.4.2 Cabinet	18
1.4.3 LCD Display	18
1.4.4 Membrane Switch Panel	18
1.4.5 Transformer Assembly	18
1.4.6 Batteries	18
1.5 Optional Devices & Option Modules	19
1.5.1 Digital Communicator	19
1.5.2 UDACT	19
1.5.3 Network Interface Board - NIB-96	19
1.5.4 Field Charger/Power Supply - FCPS-24	20
1.5.5 Battery Charger - CHG-120	20
1.5.6 Liquid Crystal Display - LCD-80	20
1.5.7 Option Module: Transmitter Module - 4XTM	20
1.5.8 Option Module: Relay/Transmitter Module - RTM-8	20
1.5.9 Meter Module	20
1.5.10 Trim Ring	21
1.5.11 Battery Box	21
1.5.12 Dress Panel	21
1.5.13 Expansion Power Supplies (AVPS-24 and APS-6R)	21
1.5.14 Marine Cabinet	21
1.6 Intelligent Detectors	21
1.7 Addressable Modules	22
1.7.1 Overview	22
1.7.2 Module Descriptions	22
1.8 End-of-Line Devices	24
1.8.1 Overview	24
1.9 Annunciation Modules	24
1.9.1 Overview	24
1.9.2 Annunciator Control Module-8R (ACM-8R)	24
1.9.3 LDM Series Lamp Driver Modules	24
1.9.4 Annunciator Control System (ACS)	25
1.9.5 Annunciator Fixed Modules	25
1.10 EIA-232 Peripheral Devices (TB4)	26
1.10.1 Overview	26
1.10.2 PRN Remote Printer	26
1.10.3 Keltron Remote Printer (Model VS4095)	26
1.10.4 CRT-2 Display Terminal	26
1.11 Specifications	27
1.11.1 Primary AC Power (TB7)	27
1.11.2 Battery (lead-acid only)	27
1.11.3 Signaling Line Circuit (TB6)	27
1.11.4 Notification Appliance and Releasing Circuits (TB2)	27
1.11.5 Relays (TB3)	28
1.11.6 24 VDC Power (TB1)	28
1.12 Cabinet Dimensions	28
1.12.1 Surface Mount with a BB-17 Battery Box	28

1.12.2 Semi-flush Mount	29
Section 2 Installation	30
2.1 Preparing for Installation.....	30
2.1.1 Unpacking the System	30
2.1.2 Installation Notes	30
2.1.3 Standards and Codes	30
2.2 Installation Checklist.....	31
2.3 Backbox Mounting.....	32
2.4 AC and DC Power Connections	33
2.4.1 AC Power Connections (TB7)	33
2.4.2 Battery Power Connection (J3)	34
2.4.3 Expansion Power Supplies – AVPS-24 or APS-6R (Optional)	34
2.5 DC Output Power Connections (TB1)	35
2.6 Output Circuits (TB2)	35
2.6.1 Notification Appliance Circuits	35
2.7 Standard Relays (TB3)	36
2.8 EIA-232 Devices – Remote Printers and CRTs (TB4)	37
2.8.1 Overview	37
2.8.2 Printer Configuration	37
2.8.3 Installation	37
2.8.4 Keltron Printer	38
2.8.5 CRT Connections	39
2.9 Wiring a Signaling Line Circuit (SLC).....	41
2.9.1 Overview of SLC Wiring	41
2.9.2 SLC Devices	42
2.9.3 Control Panel Capacity	42
2.9.4 SLC Performance	43
2.9.5 SLC Shield Termination	43
2.9.6 Setting an SLC Address for a Module	44
2.9.7 Wire Requirements for a Two-wire SLC	45
2.9.8 Wire Requirements for a Four-wire SLC	46
2.9.9 Wiring an Isolator Module (ISO-X)	49
2.9.10 Wiring an IDC with Monitor Modules	50
2.9.11 Wiring a Notification Appliance Circuit (NAC) or Control Circuit	56
2.9.12 SLC Wiring with Control Modules	57
2.9.13 SLC Wiring with an Intelligent Detector	59
2.9.14 SLC Wiring with an NBG-12LX Addressable Manual Pull Station	60
2.10 Option Module Installation.....	61
2.10.1 Overview	61
2.10.2 Installing a 4XTM Module	62
2.10.3 Installing an RTM-8 Module	63
Section 3 Programming.....	65
3.1 Overview	65
3.1.1 Programming Methods	65
3.1.2 In This Section	65
3.2 Getting Started	66
3.2.1 How to Access Programming Options	66
3.2.2 Programming Passwords	66
3.2.3 How to Use the Programming Keypad	67
3.2.4 Programming Shortcuts	68
3.2.5 Upload and Download	68
3.2.6 Key Programming Terms	68
3.2.7 How to Avoid Programming Errors	69
3.3 Program Change Options.....	70
3.3.1 Overview	70
3.4 How to Enter Program Change.....	71
3.4.1 Program Change Map	72

3.4.2	How to Clear a Program from Memory (0=clr)	73
3.4.3	How to Autoprogram the Control Panel (1=auto)	73
3.4.4	How to Edit or Delete a Point (2=point)	78
3.4.5	How to Change a Programming Password (3=passwd)	85
3.4.6	How to Change a System Message (4=message)	86
3.4.7	How to Change a Zone Label (5=zones)	86
3.4.8	How to Edit a Special Zone (6=spl zones)	87
3.4.9	How to Edit System Functions (7=sys)	89
3.4.10	How to Check the Program (8=check)	92
3.5	Status Change Options	92
3.5.1	Overview	92
3.5.2	Entering Status Change	93
3.5.3	Status Change Programming Map	94
3.5.4	How to Disable or Enable a Point (1=disable)	95
3.5.5	How to Set Detector Selections (2=sens/comp)	96
3.5.6	How to Clear Alarm Verification Counters (3=clr ver)	97
3.5.7	How to Clear the History Buffer (4=clr hist)	98
3.5.8	How to Set the System Time and Date (5=time)	98
3.5.9	How to do a Walk Test (6=walk test)	99
Section 4	Operation	101
4.1	Overview	101
4.2	The Membrane Panel	102
4.2.1	Overview	102
4.2.2	How to Use the Programming Keypad	102
4.2.3	How to Use the Enter Key and Cursor Keys	103
4.2.4	How to Use the Operator Keys	103
4.2.5	How to Read System Status LED Indicators	105
4.3	How to Operate the Control Panel	106
4.3.1	How to Operate the Panel in Normal Operation	107
4.3.2	How to Operate a Panel with a Trouble Condition	107
4.3.3	How to Operate a Panel with a Trouble Monitor Point	109
4.3.4	How to Operate a Panel with a Fire Alarm	109
4.3.5	How to Operate a Panel with a Supervisory Condition	110
4.3.6	How to Operate a Panel with a Non-Alarm Condition	111
4.3.7	How to Operate the Panel with an Output Circuit Trouble	111
4.3.8	How the Control Panel Indicates a Panel Circuit Trouble	112
4.4	Control-By-Event Operation	112
4.5	Releasing Functions	113
4.5.1	Overview	113
4.5.2	How to Select Cross Zone Options	113
4.6	Releasing Functions	114
4.7	Intelligent Detector Functions	115
4.7.1	Summary of Detector Functions	115
4.7.2	Pre-Alarm Operation/Advanced Warning Addressable Combustion Sensing (AWACS™)	115
4.8	Time Functions	116
4.8.1	Overview	116
4.8.2	Coding Operation (NAC only)	117
4.8.3	Presignal/PAS Operation	117
4.8.4	Special System Timers	118
4.8.5	Waterflow Circuits Operation	118
4.8.6	Disable/Enable Operation	118
4.8.7	Style 6 Operation	118
4.9	Read Status	118
4.9.1	Overview	118
4.9.2	How to Enter Read Status	119
4.9.3	Read Status Options	119
4.9.4	Read Point	119
4.9.5	Using the History Buffer	124

Appendix A Power Supply Calculations.....	126
A.1 Overview	126
A.2 Calculating the AC Branch Circuit.....	126
A.3 The Main Power Supply	127
Current Limitations in Standby	127
Current Limitations in Alarm – System Operation on Primary Power	127
A.4 Calculating the System Current Draw	128
Overview	128
How to Use Table 47 to Calculate System Current Draws	128
A.5 Calculating the Battery Size.....	130
A.6 Selecting and Locating Batteries	131
A.7 NFPA Battery Requirements	131
Appendix B NFPA Applications.....	132
B.1 Section Overview	132
Specific Requirements	132
Additional Requirements	132
B.2 Central Station Fire Alarm Systems (Protected Premises)	133
Installing a Notifier 911AC	133
Installing a UDACT	134
B.3 NFPA 72 Auxiliary Fire Alarm System.....	135
B.4 Wiring a Remote Station Fire Alarm System	136
Overview	136
Using a 4XTM Module	137
Using an RTM-8 Module	138
B.5 NFPA 72 Proprietary Fire Alarm Systems	138
Appendix C Annunciators.....	140
C.1 LCD-80 Display	140
ACS Mode	140
Terminal Mode	140
C.2 Terminal Mode (LCD-80) Annunciation Interface (TB5 on CPU)	140
C.3 ACS Annunciation Interface (TB5 on CPU)	141
Supported Modules	141
C.4 Annunciator Capacity	141
Data Formats for Annunciator Address 1	141
Data Formats at Annunciator Address 2	141
C.5 Terminal Mode EIA-485 Connections (TB5).....	144
C.6 LCD-80 ACS Mode EIA-485 Connections	145
C.7 Power Connections for LCD and ACS Series Annunciators	146
C.8 ACS and LDM Series EIA-485 Connections	147
Appendix D Releasing Applications	148
D.1 NFPA Standards.....	148
D.2 Programming Releasing Zones	148
Releasing Zone Functions	149
Delay Timer	149
Cross Zoning	149
Soak Timer (NFPA 16 Applications Only)	150
Abort Timer	151
Special Module Type Codes	151
Abort Switch	151
Man. Release	151
Rel Ckt ULC	152
Release Ckt	152
Initiating Devices	152
Warning Sounders	152
Auxiliary Control Relay Functions	153
ACS Annunciation	153
Deluge/Pre-Action Release	153
D.3 Connecting Releasing Devices.....	153

Connecting a Releasing Device to a Control Panel through an SLC Control or Relay Module	154
Connecting an NBG-12LRA Agent Releasing Abort Station	154
Appendix E Combination Fire/Burglary Applications	157
E.1 Overview	157
E.2 Installation	157
Installation Overview	157
Installing a Tamper Switch	157
Wiring for Proprietary Security Alarm Applications	158
Connecting to an AM2020/AFP1010 Receiving Unit	159
E.3 Programming	159
E.4 Operation	160
Overview	160
Configuring the Keypad for a Security LED Indicator	160
Control Panel Operation in a Security Condition	160
Appendix F Wire Requirements.....	161
Appendix G Pre-Alarm (AWACS™) Applications	162
G.1 Overview	162
G.2 Pre-Alarm Applications.....	162
Pre-Alarm Alert Level	162
Action Level Pre-Alarm Function	163
G.3 Pre-Alarm Programming.....	163
Pre-Alarm Programming Screen	163
Selecting Pre-Alarm Application Levels	164
Self-Optimizing Pre-Alarm Function	165
Audible Warning Applications for AWACS™	166
Appendix H Special Zones.....	167
H.1 Overview	167
H.2 Presignal and Positive Alarm Sequence (PAS).....	167
Presignal	167
Positive Alarm Sequence (PAS)	167
H.3 Time Control	168
H.4 NAC Code Types.....	168
Appendix I Terminal Interface Protocol	169
I.1 General Description	169
I.2 Operating Modes.....	169
Local Terminal Mode (LocT)	169
Local Monitor Mode (LocM)	170
Remote Terminal Mode (RemT)	170
I.3 Using the CRT-2 for Read Status	171
Overview	171
Accessing Read Status Options	171
Read Point	172
Display Devices in Alarm or Trouble	172
Display the Status of all Programmed Points	172
View the History Buffer	173
Send the History Buffer to the CRT-2	173
I.4 Using the CRT-2 for Alter Status	173
Overview	173
Accessing Alter Status Options	174
Enable or Disable Detectors, Modules, or Bell Circuits	174
Change Detector Sensitivity Levels	175
Clear the Verification Counter	175
Clear the Entire History Buffer	175
Set the Pre-Alarm for Alert or Action Level	176
CRT-2 Configuration	176
Appendix J Expansion Power Supplies.....	177
J.1 Overview	177

AVPS-24 Audio/Visual Power Supply	177
APS-6R Auxiliary Power Supply	177
J.2 Programming.....	179
J.3 Supply Calculations	179
AVPS-24/AVPS-24E Calculations	179
APS-6R Calculations	180
J.4 Installation	180
Installing the AVPS-24/AVPS-24E	180
Installing the APS-6R	183
Appendix K UL Power-limited Wiring Requirements	186
K.1 Overview	186
K.2 Typical Circuit with Nonpower-limited and Power-limited Wiring	186
Appendix L U.S. Coast Guard & Lloyd's Register	187
Appendix M CBE Programming.....	189
M.1 Purpose.....	189
M.2 Software Zones	189
M.3 How to Program CBE	189
CBE Example 1	189
CBE Example 2	190
Appendix N External Battery Charger.....	191
N.1 Overview	191
N.2 Installation Requirements	191
N.3 Mounting the CHG-120.....	191
Mounting the Charger into a CAB-X3 Series Cabinet	191
Mounting the Charger into a Battery Box	192
N.4 Connecting the CHG-120	194
Connecting a CHG-120 to the AFP-200	194

About This Manual

Scope of this Manual

This manual contains the following:

Section 1 “System Overview” provides a description of the control panel and system components, a list of related system documentation, electrical specifications, and cabinet dimensions.

Section 2 “Installation” provides instructions for installing the basic and optional system components, and provides a checklist for testing an installed system and the batteries.

Section 3 “Programming” provides instructions for customizing the fire alarm system by selecting and setting program options for addressable SLC devices, NACs, and Panel Circuits.

Section 4 “Operation” provides instructions for operator use of the fire alarm system.

Appendix A “Power Supply Calculations” provides current draws for system components and calculation tables for determining the power required to operate the control panel during fire alarm and AC loss of power conditions.

Appendix B “NFPA Applications” provides information and wiring diagrams for setting up the control panel for NFPA applications.

Appendix C “Annunciators” provides information about annunciating control panel points and contains instructions and wiring diagrams for connecting annunciators to the control panel.

Appendix D “Releasing Applications” provides information and wiring diagrams for setting up the control panel for releasing applications.

Appendix E “Combination Fire/Burglary Applications” provides information and wiring diagrams for setting up the control panel for security applications.

Appendix F “Wire Requirements” provides wire requirements for circuits connected to the control panel.

Appendix G “Pre-Alarm (AWACSTM) Applications” provides information and wiring diagrams for setting up the control panel for AWACs applications.

Appendix H “Special Zones” provides descriptions and options for Special Zones used to define presignal and PAS selections, Time Control selection, Holiday selections, and NAC Code Types.

Appendix I “Terminal Interface Protocol” provides detailed information about the terminal operating modes: Local Terminal Mode (LocT), Local Monitor Mode (LocM), and Remote Terminal Mode (RemT). The appendix also contains instructions for using a CRT-2 for Read Status and Alter Status (Change Status) operations.

Appendix J “Expansion Power Supplies” provides information and wiring diagrams for setting up the panel to use external power supplies.

Appendix K “UL Power-limited Wiring Requirements” provides UL wiring requirements and sample wiring diagrams for power-limited and nonpower-limited wiring.

Appendix L “U.S. Coast Guard & Lloyd’s Register” provides a list of equipment suitable for use in marine and shipyard applications as compatible with this control panel.

Appendix M “CBE Programming” provides information and programming examples to set up the fire alarm system to use Control-by-Event.

Appendix N “External Battery Charger” provides information and wiring diagrams for setting up an external battery charger for use with the panel.

Notes, Cautions, and Warnings

This manual contains notes, cautions, and warnings to alert the reader to as follows:

- **Note** – Supplemental information for a topic, such as tips and references, that typically appear in the left margin.
- **Caution** – information about procedures that could cause programming errors, runtime errors, or equipment damage.
- **WARNING** – indicates information about procedures that could cause irreversible damage to the control panel, irreversible loss of programming data or personal injury.



Typographic Conventions

For presentation and printing, this manual uses different typeface characters, in place of the actual LCD letters that you see on the LCD display. This manual uses the following conventions for entering data and pressing control panel keys, as listed in Table 1:

When you see	Specifies	Example
text in small caps	the way the text appears in the LCD display	MARCH TIME is a selection that appears in the LCD display TAMPER shows a Type Code selection as it appears in the LCD display
text in quotes	a reference to a section	“Program Change” specifies the Program Change section.
bold text	In body text, a key on the control panel	Press the Enter key Press the 1 key
a graphic of the key	In a graphic, a key as it appears on the control panel	Press 

Table 1 Typographic Conventions in this Manual

General Terms

Unless noted, general terms reference the specific part numbers listed Table 2:

General Term	Specific Part Number(s)
Auxiliary Power Supply	APS-6R
AVPS-24	AVPS-24/AVPS-24E
Control module	FCM-1
CPU	AFP-200 circuit board
CRT	CRT-2
LCD display	80-character LCD (liquid crystal display)
Monitor Module	FMM-1 or FMM-101
PRN	PRN-5
Relay module	FRM-1

Table 2 General Terms

Supplemental Information

Table 3 contains a list of documents that contain additional information on the AFP-200:

For information on	Refer to	Part Number
All features	AFP-200 Data Sheet	DN-3783
System Connections	AFP-200 Basic System Drawing	51265
Compatible Devices	Device Compatibility Document	15378
Off-line programming and installation	Veri•Fire Medium Systems CD: AFP-200 Upload/Download Utility	Verifire-CD
Networking applications	NAM-232 Network Adaptor Module Manual	50038
Networking applications	Noti•Fire•Net Manual	50257
	Noti•Fire•Net Manual, Network Version 4.0 & Higher	51584
SLC Wiring Instructions	SLC Wiring Manual	51253
Annunciators	Annunciator Control System	15842
	Annunciator Fixed Module	15048
	ACM-8R Annunciator Control Module	15342
	LDM Series Lamp Driver Annunciator	15885
	LCD-80 Manual	15037
	LCD-80TM Manual	51082
	RPT-485W/RPT-485WF EIA-485 Annunciator Loop Repeater	15640
Auxiliary Power Supplies and Battery Chargers	APS-6R Installation Manual	50702
	ACPS-2406 Auxiliary Power Supply Manual	51304
	CHG-120 Battery Charger Manual	50641
	FCPS-24 Field Charger/Power Supply	50059
Cabinets	CAB-3 Installation Drawing	15330
Network Interface	NIB-96 Network Interface Board	15666
Transponders	XP5 Series Manual	50786
	DPI-232 Manual	51499
	RFX Wireless Interface System	51012
Universal Digital Alarm Communicator/Transmitter	The UDACT Manual	50050
	911AC Manual	74-06200-005
	411UD	50759
	411	50921
	411UDAC	51073
Universal Zone Coder	UZC-256 Universal Zone Coder	15216
	UZC-256 Programming	15976
Voice Alarm Systems	VEC-25/50 Voice Alarm System Manual	50686
	RM-1 Series Remote Microphone - PID	51138

Table 3 Supplemental Documentation

Agency Standards and Compliance

This control panel complies with the following NFPA standards:

- NFPA 12 CO₂ Extinguishing Systems (High Pressure Only)
- NFPA 12A Halon 1301 Extinguishing Systems
- NFPA 12B Halon 1211 Extinguishing Systems
- NFPA 13 Sprinkler Systems
- NFPA 15 Water Spray Systems
- NFPA 16 Foam/Water Deluge and Foam/Water Spray Systems
- NFPA 17 Dry Chemical Extinguishing Systems
- NFPA 17A Wet Chemical Extinguishing Systems
- NFPA 72 Central Station Signaling Systems (Automatic, Manual, and Waterflow). Protected Premises Unit (Requires 411UDAC or NOTI•FIRE 911AC DACT or MS-5012 Slave Communicator)*
- NFPA 72 Local Fire Alarm Systems
- NFPA 72 Auxiliary Fire Alarm Systems. (Requires 4XTM or RTM-8)
- NFPA 72 Remote Station Fire Alarm Systems. (Requires 4XTM or 411UDAC DACT or NOTI•FIRE 911AC DACT*)
- NFPA 72 Proprietary Fire Alarm Systems (Protected Premises Unit) (Requires Potter #EFT-C McCulloh Transmitter)*
- NFPA 2001 Clean Agent Fire Extinguishing Systems
- United States Coast Guard–Fire Protection System. (Marine Approvals require CAB-AM.)
- Lloyd’s Register –Marine, Offshore and Industrial Category ENV1 and ENV2*

* Applications which require the 411UDAC, the NOTI-FIRE 911AC, or the Potter EFT-C are not FM approved.

The installer should also be familiar with the following documents and standards:

NFPA Standards



- NFPA 72 Automatic Fire Detectors
- NFPA 72 Installation, Maintenance, and Use of Notification Appliances for Fire Alarm Systems
- NFPA 72 Testing Procedures for Signaling Systems
- NFPA 2001 Clean Agent Fire Extinguishing Systems



Underwriters Laboratories Documents:

- UL 38 Manual Actuated Signaling Boxes
- UL 217 Smoke Detectors, Single and Multiple Station
- UL 228 Door Closers - Holders for Fire Protective Signaling Systems
- UL 268 Smoke Detectors for Fire Protective Signaling Systems
- UL 268A Smoke Detectors for Duct Applications
- UL 346 Waterflow Indicators for Fire Alarm systems
- UL 464 Audible Signaling Appliances
- UL 521 Heat Detectors for Fire Protective Signaling Systems
- UL 864 Standard for Control Units for Fire Protective Signaling Systems
- UL 1481 Power supplies for Fire Protective Signaling Systems
- UL 1638 Visual Signaling Appliances
- UL 1076 Proprietary Burglar Alarm Systems



Standard CAN/ULC-S527-M87 Standard for Control Units for Fire Alarm Systems

Other:

- EIA-485 and EIA-232 Serial Interface Standards
- NEC Article 300 Wiring Methods
- NEC Article 760 Fire Alarm Systems
- Applicable Local and State Building Codes
- Requirements of the Local Authority Having Jurisdiction
- Notifier Device Compatibility Document
- ADA Americans with Disabilities Act

Section 1 System Overview

1.1 General Description

The AFP-200 is a compact, cost-effective, intelligent fire alarm control panel with an extensive list of powerful features. The power supply and all electronics are contained on a single circuit board, providing a complete fire control system for most applications. Optional modules which plug into the main circuit board are available for special functions.

1.2 Features

- Single standard communication (SLC) loop, meets NFPA Style 4, 6, or 7 requirements
- 198 intelligent device capacity
- Four Notification Appliance Circuits standard
- Optional RTM-8 eight-zone relay module with transmitter
- Optional 411, 411UD, 411UDACT, or 911AC Digital Alarm Communicator/Transmitter
- Optional UDACT Universal Digital Alarm Communicator/Transmitter
- LCD-80 liquid crystal display, mounts up to 6,000 feet (1,828.8 m) from panel
- ACS annunciators, including LDM custom graphic annunciators
- ACM-8R remote relay module, increases point capacity
- Printer interface
- Real time clock, with European format option
- History file with 650 event capacity
- Intelligent features
- Sensitivity display in percent
- Manual sensitivity adjustment
- Day/Night automatic sensitivity adjustment
- Drift compensation (U.S. patent pending)
- Auto detector test (meets NFPA 72)
- Maintenance Alert
- Pre-Alarm (AWACS™ — 2 levels)
- LED blink control
- Releasing features
- Four independent hazards
- Cross zone (three methods)
- Delay timer
- Soak timer
- Abort — four options
- Manual release
- Waterflow (non-silenceable) selection per module point
- Supervisory selection per point with separate LED
- Alarm Verification
- Walk Test
- Positive alarm sequence (PAS) pre-signal per NFPA 72
- Silence Inhibit timer option
- Auto silence timer option
- March time/temporal code
- Two-stage option for Canada
- California code
- Tornado warning code
- Remote Ack/Silence/Reset/Drill via Monitor Modules
- Automatic time control functions, with holiday exceptions
- Autoprogram (learn mode) reduces installation time
- Password- and key-protected nonvolatile memory.
- Programmable from a PC with a Windows®-based programming utility
- Rapid poll algorithm for manual stations (U.S. patent pending)
- Operates up to 1,000 feet (304.8 m) with untwisted, unshielded wire (U.S. Patent 5,210,523)
- Operates sounder base on Action Pre-Alarm level with general evacuation on alarm level.
- Burglar alarm point option.
- Read status on program via modem using dial-up phone lines.
- Marine cabinet option (CAB-AM)

Figure 1 identifies major features of the control panel.

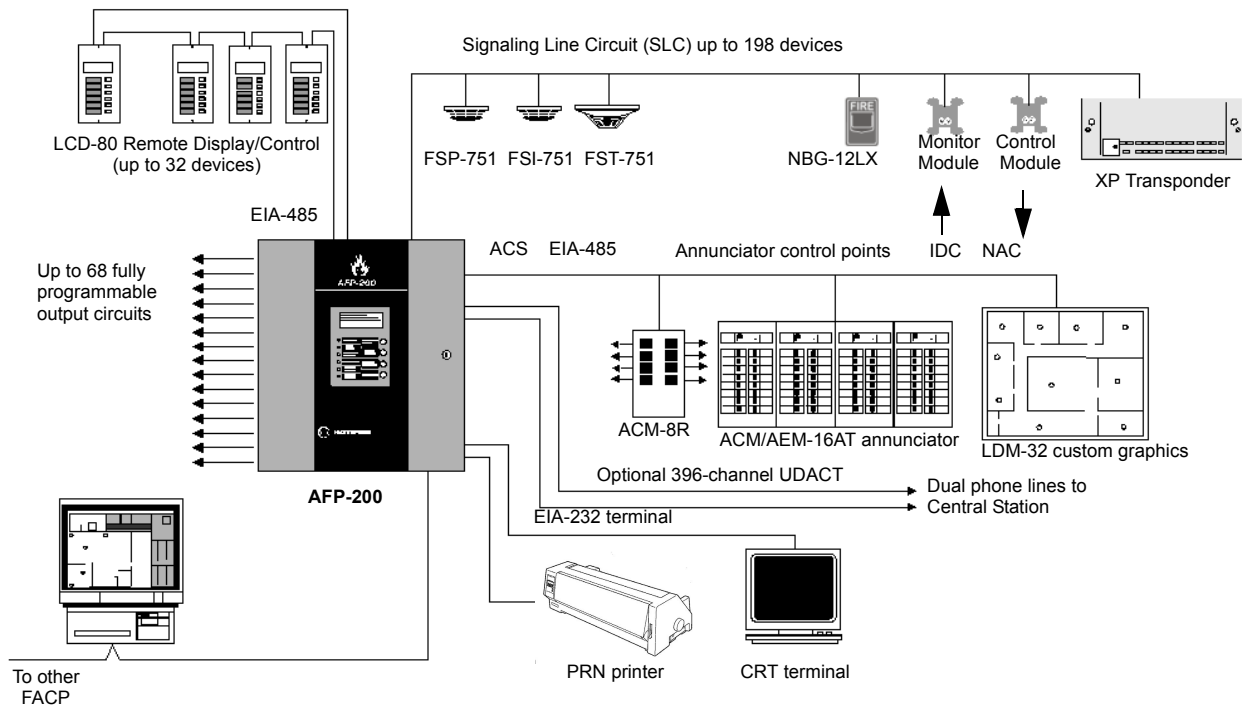

Figure 1 AFP-200 System Features

1.3 Components

1.3.1 Membrane Switch Panel

Figure 2 shows the membrane switch panel which includes the following:

- Windows for the Liquid Crystal Display (LCD) and six system status indicator LEDs.
- Programming keys, including a 12-key alphanumeric pad (similar to a telephone keypad) an ENTER key, and four arrow movement keys.
- Slide-in labels, which provide switch and LED description for the six system status indicator LEDs and the four operator keys.

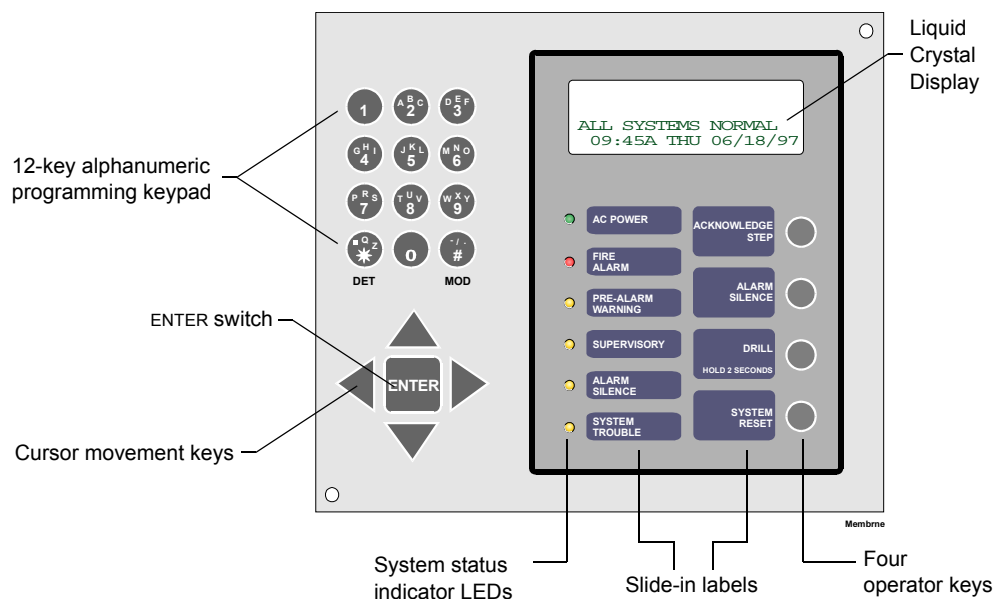

Figure 2 Membrane Switch Panel

System Status Indicator LEDs

Figure 2 shows the location of the control panel system status indicator LEDs.

- AC Power (green)
- System Alarm (red)
- Pre-Alarm Warning (yellow)
- Supervisory/Security (yellow)
- Alarm Silence (yellow)
- System Trouble (yellow)

For descriptions of each System Status LED Indicator, refer to Section 4 “Operation”.

Operator Keys

Figure 2 shows the location of the following operator keys:

- Acknowledge/Step
- Alarm Silence
- Drill
- System Reset (lamp test)

For descriptions of each operator key, refer to Section 4 “Operation”.

Programming Keypad

Figure 2 shows the location of the control panel keypad switches, the cursor keys, and the ENTER key.

- Twelve-key pad with 0-9, *, #
- Four cursor keys (up, down, right, left)
- ENTER key

1.3.2 Panel Sounder

The control panel provides audio signals for alarm, trouble, and supervisory/security conditions through an onboard panel sounder. For more information on the panel sounder, refer to Section 4 “Operation”.

1.3.3 Output Circuits (TB2)

Output circuits consist of four Class B (Style Y) Notification Appliance Circuits (NACs) or releasing circuits (fully programmable). For installation instructions, refer to “Output Circuits (TB2)” on page 35.

1.3.4 Relays (TB3)

The control panel includes three dry contact relays for system alarm, system trouble, and supervisory. Contacts are rated 2 A at 30 VDC and 0.5 A at 30 VAC (resistive). For installation instructions, “Standard Relays (TB3)” on page 36.

1.4 Main Assemblies

The AFP-200 main assemblies include the CPU board, the cabinet for enclosing the control panel, the transformer assembly, and the batteries.

1.4.1 CPU Board

The control panel circuit board contains the system's central processing unit (CPU), power supply, and other primary components. The CPU is delivered pre-mounted in the cabinet. Figure 3 shows the components of the CPU board, such as terminals, LEDs, and connectors. For details of the membrane switch panel, see Figure 2 on page 15.

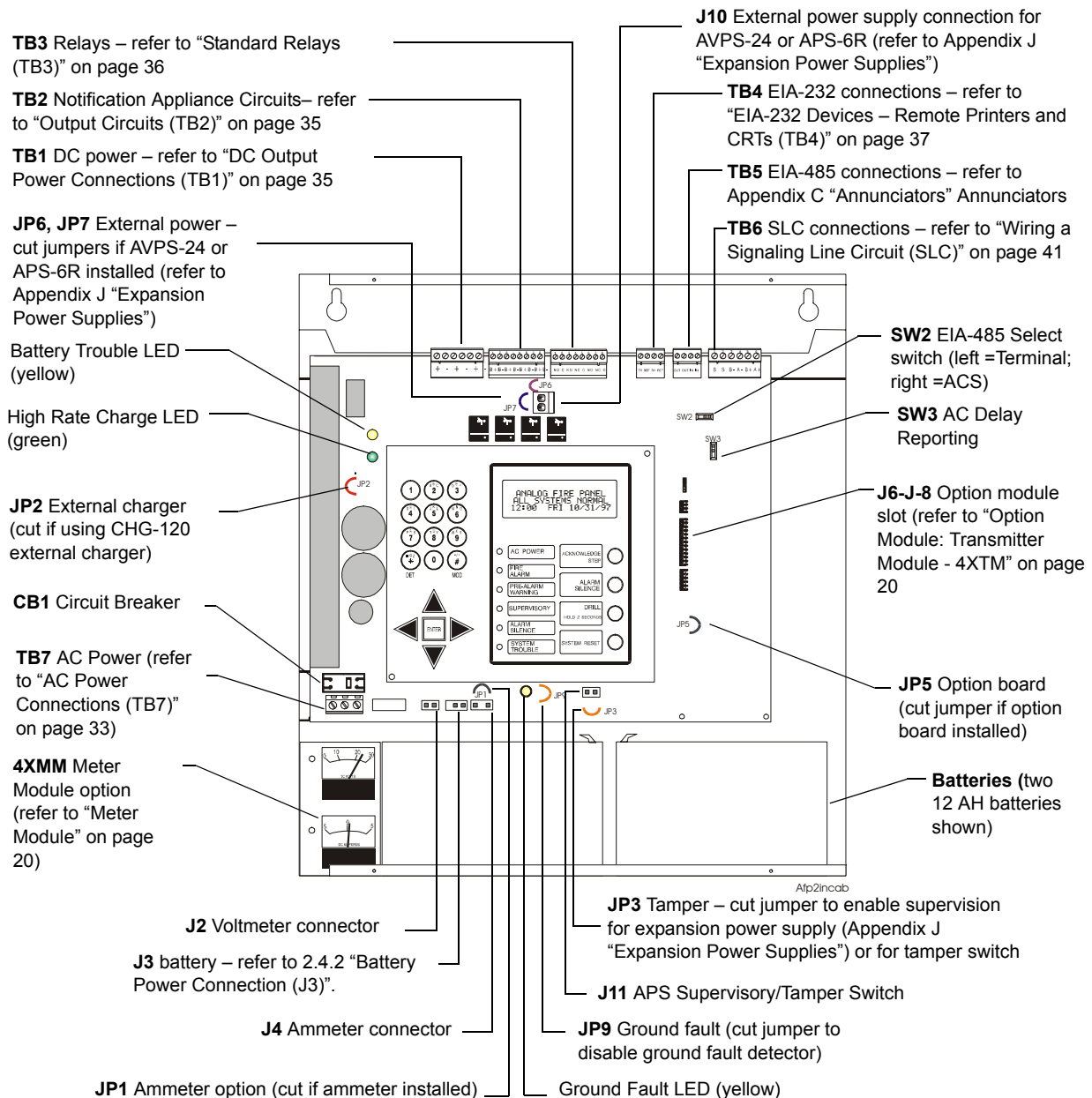
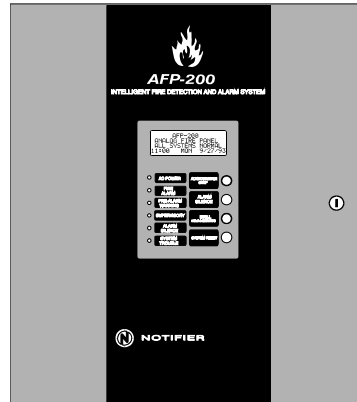

Figure 3 Connections and Controls (Shown Without Dress Panel)

1.4.2 Cabinet

The CPU board mounts in a compact (16.125" x 14.5" x 5.5") cabinet with a front dress plate. The cabinet provides space for two batteries (up to 12 AH).



1.4.3 LCD Display

The control panel uses an 80-character LCD display (4 rows of 20 characters each). The display includes a long-life LED backlight that remains on unless AC power is lost while the system is not in alarm:

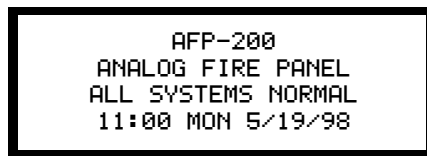
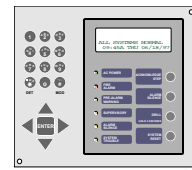

Figure 4 LCD Display

1.4.4 Membrane Switch Panel

The membrane switch panel provides LED Status Indicators, operator keys, and programming keys. The operator keys and LEDs are visible with the cabinet door closed. The programming keys are visible only with the door open. Slide-in labels are provided for switch and LED descriptions. Refer to “Membrane Switch Panel” on page 15.



1.4.5 Transformer Assembly

The transformer assembly includes two 100 VA transformers and a connector.

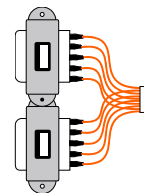

1.4.6 Batteries

The cabinet provides space for 7 AH or 12 AH batteries (for 18 AH batteries use the BB-17 battery box). Batteries must be ordered separately.

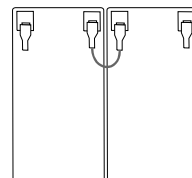

1.5 Optional Devices & Option Modules

Several optional components can be installed within this fire alarm control system, including external devices and “option modules” that plug directly into the CPU. The CPU board includes an option module slot located on the right side of the board. When an option module is installed, jumper JP5 (Figure 3 on page 17) must be cut. The option slot supports a 4XTM or RTM-8 module.

For instructions on installing an option module, refer to 2.10 “Option Module Installation”.

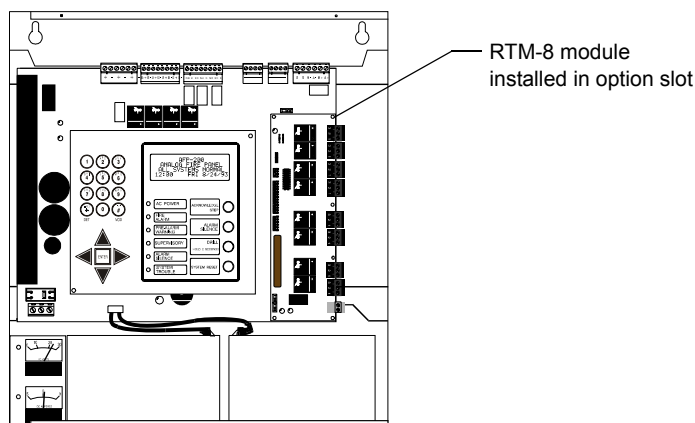

Figure 5 Option Module Slot (Shown with RTM-8 Module)

Further information and installation instructions for specific devices are provided in those product manuals; for part numbers of manuals refer to Table 3, “Supplemental Documentation,” on page 12.

1.5.1 Digital Communicator

The 911AC Digital Alarm Communicator/Transmitter transmits three zones of information (System Alarm, System Trouble, Supervisory) to the central station or remote station receiver. Fully UL-listed for fire operation (NFPA 72), the 911AC requires two standard dial-up telephone lines to operate. For details, refer to the 911AC Manual.

1.5.2 UDACT

The UDACT transmits system status for up to 99 zones to UL-listed Central Station Receivers over a public switched telephone network. It mounts remotely in the ABS-8R enclosure. The unit connects to the EIA-485 annunciator port and 24 VDC (nominal) power; software PN 73609 or higher must be installed. Some NFPA applications are provided in Appendix B. For further details, refer to the UDACT manual.

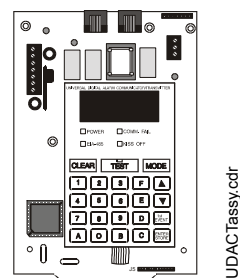

UDACTassy.cdr

1.5.3 Network Interface Board - NIB-96

A microprocessor- controlled module that connects slave control panels to a master control panel. The board can be installed in each slave FACP. Each slave FACP can contain as many as 96 input/output points, or as few as eight points. Refer to the NIB-96 Network Interface Board manual for further information and installation instructions.

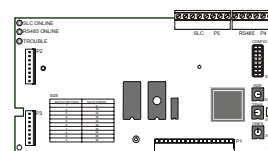

NIB-96assy.cdr

1.5.4 Field Charger/Power Supply - FCPS-24

A compact, cost-effective remote power supply and battery charger. It consists of a filtered, 24 VDC output that can drive up to four Notification Appliance Circuits (NACs). Refer to the FCPS-24 Field Charger/Power Supply manual for further information and installation instructions.

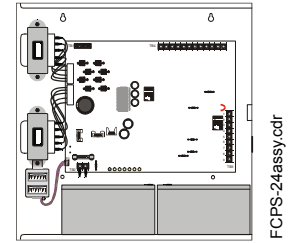

1.5.5 Battery Charger - CHG-120

Designed to charge lead-acid batteries that provide emergency standby power for a Fire Alarm Control Panel. Provides two (2) output circuits for connection to multiple loads. Can be mounted into a CAB-3 Series cabinet or a BB-55 or NFS-LBB Battery Box. For details, refer to the CHG-120 Battery Charger manual.

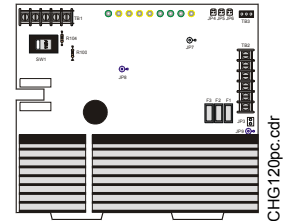

1.5.6 Liquid Crystal Display - LCD-80

An alphanumeric display module that is an ancillary device which has two basic modes of operation. In *Terminal Mode* it acts as a display interface and in *ACS Mode* as an alphanumeric annunciator. The **LCD-80TM** is also available and provides *Terminal Mode* only. Refer to the LCD-80 manual or LCD-80TM Liquid Crystal Display manual.

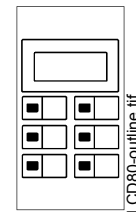

1.5.7 Option Module: Transmitter Module - 4XTM

The 4XTM provides connections to municipal box and remote station transmitters meeting NFPA 72 Auxiliary and Remote Station requirements. The 4XTM is mounted on the control panel's CPU and includes a Disable switch and an LED indicator. Refer to 2.10.2 "Installing a 4XTM Module".

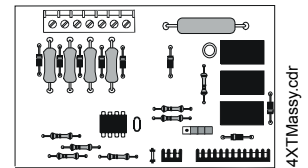

1.5.8 Option Module: Relay/Transmitter Module - RTM-8

The Relay/Transmitter Module (RTM-8) provides eight Form-C relays (5A contacts) that track software zones 1 through 8. The RTM-8 also provides Municipal Box and Remote Station transmitters NFPA 72 Auxiliary and Remote Station requirements. In remote station applications, the RTM-8 transmits alarm only and does not transmit trouble or supervisory status. Disable switches and indicators are included. Refer to 2.10.3 "Installing an RTM-8 Module".

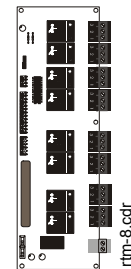

1.5.9 Meter Module

The 4XMM Meter Module provides a voltmeter to measure voltage across the batteries and an ammeter to measure charging current to the batteries. A single assembly containing both meters mounts in the lower-left corner of the AFP-200 cabinet as shown in Figure 3 on page 17.

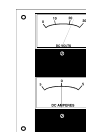

1.5.10 Trim Ring

The TR-4XG gray trim ring is available for semi-flush mounting of the control panel cabinet. See Figure 7 on page 29 for an illustration of the trim ring installed.

1.5.11 Battery Box

The BB-17 battery box may be used to mount two 18 AH batteries. The box mounts directly below the control panel cabinet. See Figure 6 on page 28 for an illustration of the battery box dimensions.

1.5.12 Dress Panel

A dead front dress panel (DP-AFP200) is available as an option (required for Canadian and FM installations).

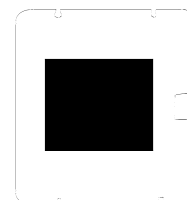

1.5.13 Expansion Power Supplies (AVPS-24 and APS-6R)

Power supply model AVPS-24/AVPS-24E provides an additional 3 amps of notification appliance power (Appendix J “Expansion Power Supplies”) and the APS-6R provides 6 amps of additional notification appliance power. Refer to the Device Compatibility Document for compatible notification appliances.

1.5.14 Marine Cabinet

Cabinet CAB-AM is required for applications requiring United States Coast Guard or Lloyd’s Register approvals. Refer to Appendix L “U.S. Coast Guard & Lloyd’s Register” on page 187.

1.6 Intelligent Detectors

Intelligent, addressable detectors provide analog information to the control panel on a Signaling Line Circuit (SLC). This allows the control panel to continually process this information to determine the status of each detector (alarm, trouble, maintenance, or normal). Each detector responds to an SLC address that is set in the detector head using built-in rotary decimal switches. The sensitivity of each intelligent detector can be programmed at the control panel. (Refer to Section 3 “Programming” for details.) Detector heads mount to a separate base for ease of installation and replacement, as described below.

A blinking LED on an intelligent detector indicates communication between the detector and the control panel.

Detectors

- **FSI-751.** Analog, addressable, low profile intelligent smoke detector that incorporates an ionization sensing chamber. Designed to provide open area protection.
- **FSP-751.** Same as FSI-751, but uses a photoelectric sensing chamber. The **FSP-751T** adds thermal sensors that will alarm at a fixed temperature of 135° F. Designed to provide open area protection.

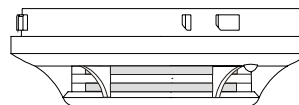

FSI-751, FSP-751

- **FST-751.** Intelligent thermistor sensing circuit for fast response. Designed to provide open area protection with 50 foot spacing capability. The **FST-751R** incorporates a thermal rate of rise of 15°F (9.4°C).
- **FSD-751P.** Photoelectric Duct Detector. The **FSD-751RP** includes an alarm relay.
- **HPX-751.** A special smoke detector that provides early warning smoke detection in hostile environments where traditional smoke detectors are not practical.

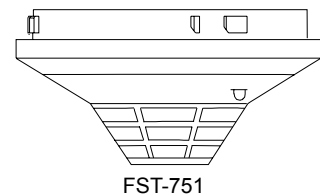

FST-751

Detector Bases

Several bases, to which the detectors are affixed, are available:

- **B710LP.** Standard U.S. Low-Profile base
- **B501.** Standard European flangeless base
- **B501BH.** Sounder base, includes B501
- **B524RB.** Intelligent relay base
- **B524BL.** Intelligent isolator base
- **B224RB.** Low Profile Intelligent relay base
- **B224BL.** Low Profile Intelligent isolator base
- **B710HD.** HARSH detector base

Accessories

The following is available:

- **RA400Z.** A Remote Single LED Annunciator that can be wired directly off of an addressable detector for annunciation of that detector's alarm status.

1.7 Addressable Modules

1.7.1 Overview

Addressable modules include:

- **Control modules.** Provide an interface between the control panel and conventional notification appliances such as horns and bells.
- **Relay modules.** Route power to relays under specified conditions; relays can control non-resistive loads within power supply limitations.
- **Monitor modules.** Provide an interface between the control panel and initiating devices, such as pull stations.

You can set each control, relay and monitor module to respond to an address with built-in rotary decimal switches.

Note: A blinking LED on a monitor, control or relay module indicates communication between the module and the control panel.

1.7.2 Module Descriptions

The monitor, control and relay modules and other addressable modules described below can be used with the control panel:

Control Modules. FCM-1 control modules are used as Notification Appliance Circuits (NACs) to power and supervise compatible, UL-listed notification appliances. Wire supervised circuits as NFPA Style Y or Style Z. Comes with a thermoplastic cover for mounting to a 4-inch (10.16 cm) square mounting box.

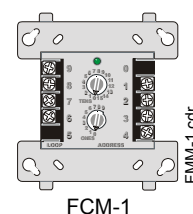

FCM-1

Monitor Modules: FMM-1, FZM-1, FMM-101.

Addressable modules used to monitor conventional initiating devices. Use the FMM-1 for normally open contact alarm initiating devices, such as manual pull stations, four-wire smoke detectors, heat detectors, waterflow, security contacts, and supervisory devices. Use the FZM-1 for specific two-wire smoke detectors in addition to normally open contacts. Wire supervised circuits as NFPA Style B or Style D circuits. Use the FMM-101 when mounting directly in the electrical box of the device being monitored; this smaller package is limited to Style B circuits only and does not include a blinking LED or a magnetic test switch.

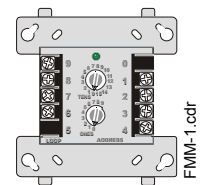

FMM-1, FZM-1

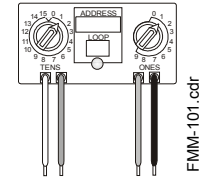

FMM-101

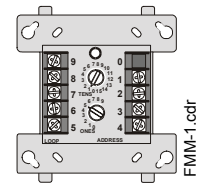

FRM-1

Relay Module. FRM-1 serves as a Form-C control relay. It resembles an FCM-1 and also comes with a thermoplastic cover for mounting to a 4-inch (10.16 cm) square mounting box.

XP5-C Modules. XP5-C Modules allow the AFP-200 to control a maximum of five individual circuits. These modules can be configured as NACs/telephone or relay circuits. Their function is similar to that of the control or relay modules described above.

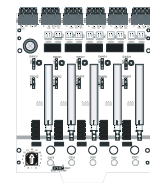

XP5-M Modules. XP5-M Modules allow the AFP-200 to monitor a maximum of five individual circuits. Their function is similar to those of the monitor modules described above.

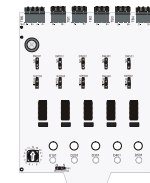

Loop Isolator Module (ISO-X). The ISO-X module is an automatic switch that opens the circuit voltage to a communications loop branch(es) whenever a fault is detected on that circuit. The remainder of the communications loop leading up to the ISO-X continues to operate, unaffected by the fault.

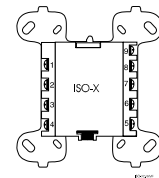

NBG-12LX. A dual action addressable manual pull station featuring a key-lock reset. The pull station includes a mini-monitor module and responds to an address set with built-in rotary decimal switches.



NBG-12LRA. A dual-action agent release station featuring an abort switch, release LED, normal LED, and a key-lock reset. The release station includes a mini-monitor module and responds to an address set with built-in rotary decimal switches.



1.8 End-of-Line Devices

1.8.1 Overview

Table 4 contains a list of the end-of-line devices that you can install in an AFP-200 system:

Option	Description	Notes
A2143-00 (System Sensor)	A 47K End-Of-Line Resistor (ELR) Assembly ELR used in the supervision of monitor, control and relay module circuits.	Supplied with monitor, control and relay modules.
A2143-10 (System Sensor)	The 3.9K End-Of-Line Resistor (ELR) Assembly used with two-wire detector modules.	Supplied with two-wire detector modules.
N-ELR Resistor plate (Notifier)	An N-ELR, required for Canadian installations, provides connection for a resistor to mount to an ELR plate. 	<ul style="list-style-type: none"> • Use 4.7K for the NAC circuits. • Use 47K for monitor, control and relay modules.

Table 4 End-of-Line Devices

1.9 Annunciation Modules

1.9.1 Overview

For instructions on installing annunciation modules, refer to Appendix C “Annunciators” on page 140.

This section contains brief descriptions and the model numbers of annunciator modules that can be connected to the control panel. Communication between the control panel and annunciators takes place over a two-wire serial interface connected to an EIA-485 connector (TB5) on the CPU. For detailed wiring requirements, refer to the appropriate annunciator manuals.

Canadian Requirement: The ACM Series annunciator modules must be used to annunciate the fire alarm input points/zones only. For Canadian applications, the following LED colors must be employed:

- Red must be used to indicate active alarm inputs
- Yellow must be used to indicate supervisory, burglary or trouble signals
- Green must be used to indicate the presence of power or an activated output

1.9.2 Annunciator Control Module-8R (ACM-8R)

The ACM-8R provides the AFP-200 with a mappable relay control module. ACM-8R relays can be selected for mapping anywhere in the system memory map (in groups of eight). Features of the ACM-8R include the following:

- Provides eight Form-C relays with 5 A contacts.
- Tracks any group of eight zones within the system.

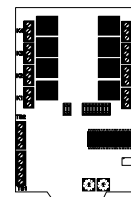

1.9.3 LDM Series Lamp Driver Modules

The LDM-32 Lamp Driver Annunciator Module provides 32 alarm lamp driver outputs for connection to a custom graphic annunciator. You can also set the LDM-32 with a DIP switch for 16 alarm, 16 trouble and 16 switch inputs for control of such system functions as Signal Silence and System Reset.

- Lamp Driver Annunciator Expander Module

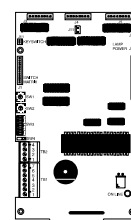

(LDM-E32) – Expands the LDM-32 by 32 system points, to a maximum of 64 points.

- Relay Expander Module (LDM-R32) – Provides the LDM-32 or LDM-E32 with 32 dry Form-A (normally open) contacts.

1.9.4 Annunciator Control System (ACS)

The ACS series annunciator and control system provides the control panel with up to 32 remote annunciators, each with a capacity of 64 points. Table 5 contains brief descriptions of ACS annunciators. For detailed information, refer to the ACS Manual.

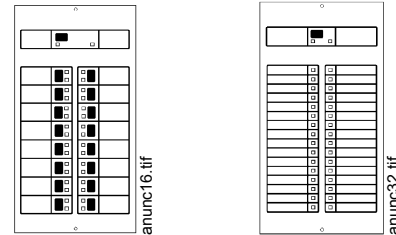

Module	Features
Annunciator Control Module-16AT (ACM-16AT)	The ACM-16AT provides features for audible and visual indication of alarm and trouble conditions at each annunciator. These features include: 1) 16 red alarm LEDs; 2) 16 yellow trouble LEDs; 3) 16 momentary touch-pad switches for controlling each point; 4) a system trouble LED; 5) an Online/Power LED; 6) a local sounder; 7) a Silence/Acknowledge switch; and remote functions.
Annunciator Expander Module (AEM-16AT)	The AEM-16AT, identical in size and appearance to the ACM-16AT, expands the ACM-16AT by 16 system points. An ACM-16AT can support up to three AEM-16ATs, to provide a maximum of 64 system points. Note: An AEM-16AT cannot be used to expand an ACM-32A.
Annunciator Control Module-32A (ACM-32A)	The ACM-32A provides features for audible and visual indication of alarm and trouble conditions at each annunciator. These features include: 1) 32 red alarm LEDs; 2) a system trouble LED; 3) an Online/Power LED; 4) a local sounder; and 5) a Silence/Acknowledge switch.
Annunciator Expander Module-32A (AEM-32A)	The AEM-32A, identical in size and appearance to the ACM-32A, expands the ACM-32A by 32 system points. An ACM-32A can support one AEM-32A, providing a maximum of 64 system points. Note: An AEM-32A cannot be used to expand an ACM-16AT.

Table 5 ACS Modules

1.9.5 Annunciator Fixed Modules

Annunciator Fixed Modules (AFM-16AT and AFM-32A) provide the control panel with discrete display and control points. AFMs turn their LEDs on and off as directed by the CPU, and also report switch activations to the CPU for action. You can only use one AFM in a system. Each annunciator's address is fixed at address 1.

- AFM-16AT – The AFM-16AT contains 16 red alarm and 16 yellow trouble LEDs, a system trouble LED, an On-line/Power LED, and a local sounder, and switches for control panel Acknowledge, Alarm Silence, and System Reset. Use the AFM-16AT for systems that require 16 or fewer annunciation points.
- AFM-32A – The AFM-32A contains 32 red alarm LEDs, a system trouble LED, an ON LINE/POWER LED, and a local panel sounder with a silence/acknowledge switch. The AFM-32A is fixed at address 1, and will not accept expander modules.

1.10 EIA-232 Peripheral Devices (TB4)

1.10.1 Overview

The control panel is compatible with the following printers and display devices that connect through the EIA-232 interface on CPU terminal TB4:

- PRN printer
- Keltron remote printer
- CRT-2 display terminal

For installation instructions for these devices, refer to “EIA-232 Devices – Remote Printers and CRTs (TB4)” on page 37.

1.10.2 PRN Remote Printer

The PRN is an optional printer that connects directly to the control panel through TB1 on the CPU and can be located up to 50 feet (15.24 m) from the control panel. It features the following:

- Provides a printed record (80 columns of data on standard 9" x 11" tractor-feed paper) of all system events (alarm, trouble) and status changes within the system.
- Time-stamps the printout with the current time-of-day and date.

Note: Time stamping is a function of the AFP-200 panel.

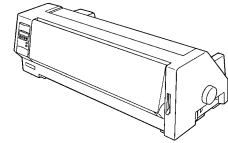

1.10.3 Keltron Remote Printer (Model VS4095)

The VS4095 is a two-color (red and black), 40-column, 24 VDC printer that can print up to 50 messages in 90 seconds. This printer connects to the EIA-232 TB4 in the control panel through TB1 on the CPU, from which it gets its power, and mounts in a separate cabinet next to the control panel. The VS4095 meets UL fire and security requirements for an ancillary device. For more information on the Keltron printer, contact the manufacturer (Keltron Corp., Waltham, MA). Refer to “Keltron Printer” on page 38 for installation instructions.

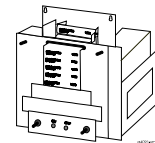

1.10.4 CRT-2 Display Terminal

The optional CRT-2 Display Terminal connects to the control panel via the EIA-232 serial interface (TB4) and can be located up to 50 feet (15.24 m) from the control panel. The CRT-2 displays data on 26 lines by 80 columns and allows you to do the following:

- Control and view events, points, and event history
- Control the system (Acknowledge, Alarm Silence, and System Reset).
- Change important system operating parameters, such as enable/disable of addressable points, change alarm and pre-alarm sensitivities, clear verification counters, clear history, and set the pre-alarm action level.



1.11 Specifications

This section contains electrical specifications for the control panel.

1.11.1 Primary AC Power (TB7)

Primary AC connections are made through TB7 on the AFP-200. Wire size: minimum 14 AWG with 600 VAC insulation.

- AFP-200. 120 VAC, 50/60 Hz, 3.0 A
- AFP-200E. 220/240 VAC, 50/60 Hz, 1.5 A

1.11.2 Battery (lead-acid only)

Maximum Charging Circuit	Dual Rate High Charge is 29.1 V @ 0.7 A Normal Flat Charge is 27.6 V @ 0.5 A
Maximum Battery Capacity	18 AH. (Batteries larger than 12 AH require a BB-17 or other UL-listed battery cabinet.)

1.11.3 Signaling Line Circuit (TB6)

Connections between the control panel and the Signaling Line Circuit (SLC) are supervised and power-limited.

Voltage	24 VDC nominal, 27.6 VDC Max.
Maximum length	10,000 ft. (3048 m) per channel (NFPA Style 4) or 10,000 ft. (3048 m) total twisted-pair length (NFPA Style 6 and 7)
Maximum loop current is	250 mA (max short circuit) or 100 mA (normal)
Maximum loop resistance	40 ohms

1.11.4 Notification Appliance and Releasing Circuits (TB2)

The following contains specifications for NACs and releasing circuits available on the AFP-200 (all circuits are power-limited).

Max. wiring voltage drop	2 VDC
Normal Operating Voltage	24 VDC.
NAC circuit 1	2.5 A
NAC circuits 2-4	2.5 A shared total
Current for all external devices	5.0 A
Optional AVPS-24/AVPS-24E	Additional 3.0 A of notification appliance power (see Appendix J “Expansion Power Supplies”)
Optional APS-6R	Additional 6.0 A of notification appliance power (see Appendix J “Expansion Power Supplies”)
Max. signaling current/circuit	2.5 A
End-of-line resistor	4.7K, 1/2-Watt (PN 71252 UL-listed) for NACs)
Releasing circuits	REL-4.7K; for control module — REL-47K

1.11.5 Relays (TB3)

Relays for Alarm, Trouble, Security, and Supervisory are available on terminal TB3 for power-limited circuits only. Contact ratings for relays through TB3 are:

- 2.0 A at 30 VDC (resistive), 0.5 A at 30 VAC (resistive)
- Alarm and Trouble: Form-C
- Supervisory: Form-A

1.11.6 24 VDC Power (TB1)

Terminal Block (TB1) provides 24 VDC power as follows:

Four-wire Smoke Detector Power (24 VDC ± 5%) – TB1-5 and TB1-6	<ul style="list-style-type: none"> • Max. ripple voltage: 10 mVrms • Up to 500 mA is available for powering four-wire smoke detectors^{1,2}
Non-resettable 24 V Power (24 VDC ± 5%) – TB1-3 and TB1-4	<ul style="list-style-type: none"> • Max. ripple voltage: 10 mVrms • Total DC current available from this output is up to 500 mA (subtracted from four-wire smoke power)²
High Ripple Regulated 24 V Power (24 VDC ± 10%) – TB1-1 and TB1-2	<ul style="list-style-type: none"> • Max. ripple voltage: 2 Vrms • Total DC current available for powering external devices is 1.0 A standby and 1.5 A alarm². This power is not recommended for LCD-80 or ACS annunciators except for an ACM-8R.
<p>¹For power supply calculations, refer to Appendix A.</p> <p>²Total current for regulated power, non-resettable power, four-wire smoke power, and four Notification Appliance Circuits must not exceed 5 A or 8 A if using an AVPS-24 (refer to Appendix J "Expansion Power Supplies") or APS-6R. Total external system current in excess of 2.5 A requires 12 AH or 18 AH batteries—not 7 AH.</p>	

1.12 Cabinet Dimensions

1.12.1 Surface Mount with a BB-17 Battery Box

Figure 6 shows dimensions for mounting a cabinet with a BB-17 Battery Box.

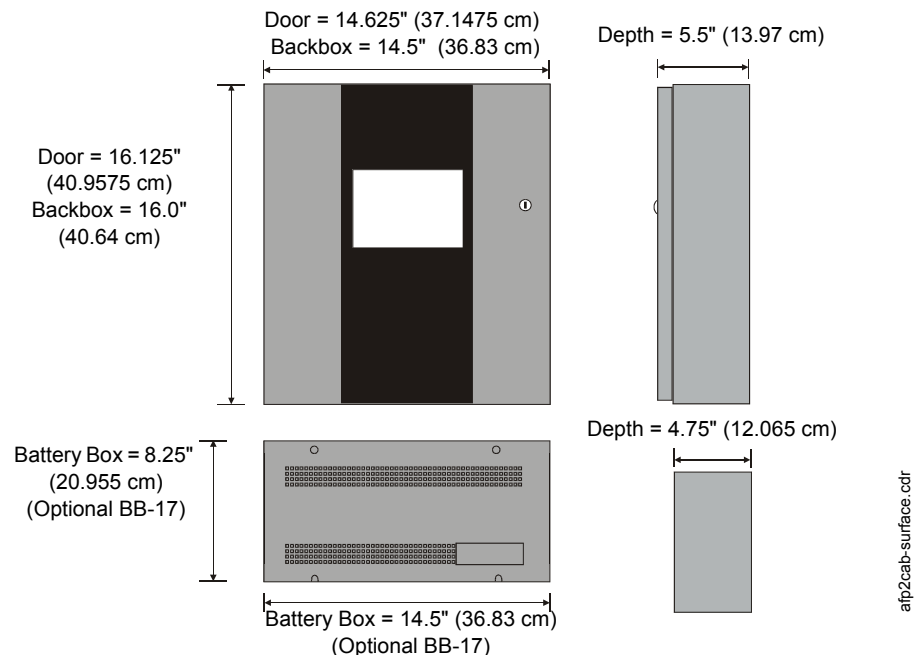

Figure 6 AFP-200 Cabinet and BB-17 Battery Box Dimensions

1.12.2 Semi-flush Mount

Figure 7 shows dimensions for semi-flush mounting of the AFP-200 cabinet using a TR-4XG Trim Ring.

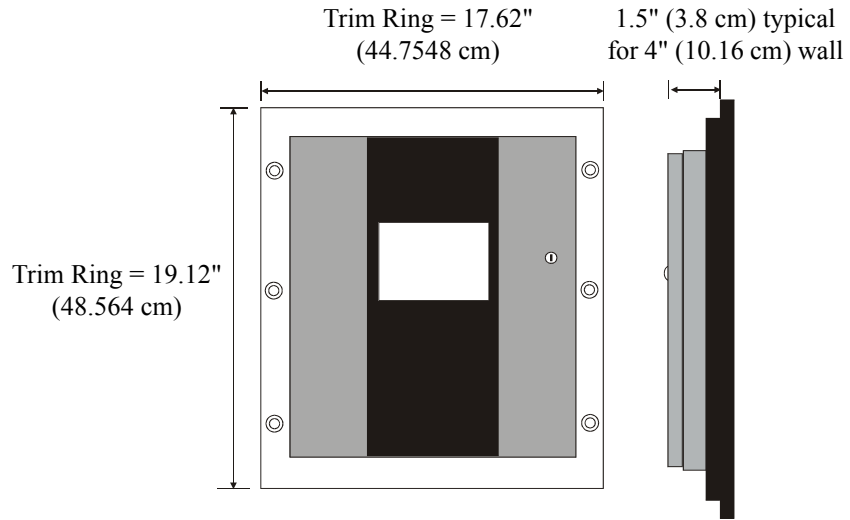

Figure 7 Dimensions with TR-4XG Trim Ring

Section 2 Installation

2.1 Preparing for Installation

2.1.1 Unpacking the System

Carefully unpack the system and inspect for shipping damage.

Select a location for the control panel in a clean, dry, vibration-free area with moderate temperature.

2.1.2 Installation Notes

Before installing the fire alarm system, read the following:

- Install the system in a readily accessible area with sufficient room to easily install and maintain the control panel.
- Locate the top of the cabinet approximately 60 inches (1.524 m) above the floor with the hinge mounting on the left.
- Count the number of conductors needed for all devices and find the appropriate knockouts.
- Review the installation precautions at the front of this manual.
- All wiring must comply with the National and/or Local codes for fire alarm systems.
- Do not draw wiring into the bottom 9 inches (22.86 cm) of the cabinet, except when using the BB-17. This prevents interference between the power supply and batteries.

2.1.3 Standards and Codes

In addition, installers should be familiar with the following standards:

- NEC Article 300 Wiring Methods.
- NEC Article 760 Fire Protective Signaling Systems.
- Applicable Local and State Building Codes.
- Requirements of the Local Authority Having Jurisdiction.

2.2 Installation Checklist



CAUTION: Make sure to install system components in the precise order in the checklist. Failure to do so can damage the control panel and other system components

Table 6 contains an installation checklist for installing, wiring, and testing an AFP-200 system:



Task	Refer to
<input type="checkbox"/> Mount the cabinet backbox to the wall.	“Backbox Mounting” on page 32
<input type="checkbox"/> If using expansion power supplies, mount the expansion power supply to the backbox.	Appendix J “Expansion Power Supplies”
<input type="checkbox"/> CAUTION: Connect the AC power cable and DC battery cables. CAUTION: Do not connect power at this time!	“AC and DC Power Connections” on page 33
<input type="checkbox"/> Mount an optional module (RTM-8 or 4XTM).	“Option Module Installation” on page 61
<input type="checkbox"/> Install optional peripheral devices, such as a printer, personal computer, or CRT-2 terminal.	“EIA-232 Devices – Remote Printers and CRTs (TB4)” on page 37
<input type="checkbox"/> Wire the Signaling Line Circuits.	“Wiring a Signaling Line Circuit (SLC)” on page 41
<input type="checkbox"/> Connect AC power to control panel — but do not connect batteries.	“AC Power Connections (TB7)” on page 33
<input type="checkbox"/> Check AC power—but do not connect batteries.	Table 7
<input type="checkbox"/> Program the control panel.	Section 3 “Programming”
<input type="checkbox"/> Connect the batteries.	“Battery Power Connection (J3)” on page 34
<input type="checkbox"/> Walk test the system.	“How to do a Walk Test (6=walk test)” on page 99

Table 6 Installation Checklist

Table 7 contains a checklist for checking the system with AC power applied:



CAUTION: While checking AC power, make sure batteries are not connected.

Component	Status
<input type="checkbox"/> The CPU	The green AC Power indicator on; the system Trouble indicator on because of no battery power.
<input type="checkbox"/> option module	The yellow Trouble indicator may come on for approximately 10 seconds after applying AC power. (This only applies to an unconfigured system.)
<input type="checkbox"/> AVPS-24/AVPS-24E or APS-6R	The yellow Trouble indicator comes on because batteries are not connected.

Table 7 AC Power Checklist

2.3 Backbox Mounting

Figure 8 shows the dimensions of the cabinet backbox:

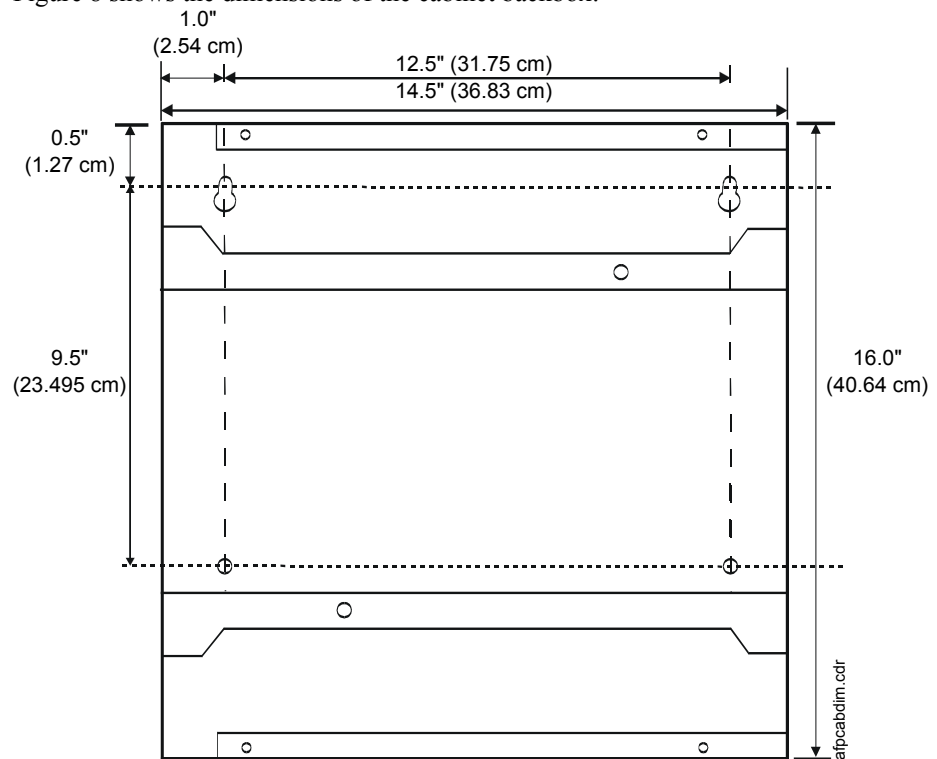

Figure 8 Backbox Dimensions

1. Remove the CPU board assembly by unscrewing the four screws in the corners of the board. Set the CPU board aside in a safe, clean place. Avoid static discharge which may damage the board.
2. Mark and predrill the four mounting bolts using dimensions shown in Figure 8.
3. Install two upper fasteners in wall with screw heads protruding.
4. Using upper keyholes, mount the backbox over the two screws. Tighten the screws.
5. Install and tighten the lower two screws.
6. When location is dry and free of construction dust, reinstall the CPU board.

2.4 AC and DC Power Connections

This section contains illustrations and instructions for connecting AC and DC power to the control panel.



WARNING: Several different sources of power can be connected to the control panel. Disconnect all sources of power before servicing. The control panel and associated equipment may be damaged by removing and/or inserting cards, modules, or connecting cables while this control panel is energized.



WARNING: Use extreme caution when connecting power—high voltage and AC line-connected circuits are present in the control panel. Turn off and remove all power sources. To reduce the risk of electric shock—make sure to properly ground the control panel.

2.4.1 AC Power Connections (TB7)

Primary power required for the AFP-200 is 120 VAC, 50/60 Hz, 3 A and primary power required for the AFP-200E is 220/240 VAC, 50/60 Hz, 1.5 A. Overcurrent protection for this circuit must comply with Article 760 of the National Electrical Code (NEC) and/or local codes. Use 14 AWG or larger wire with 600 VAC rating. Connect AC power, using a grounded power cord, to the TB7 on the control panel as follows:

1. Turn off all power sources to the control panel.
2. Insert the stripped ends of the power cord through the knockout on the bottom of the control panel (Figure 9).
3. Connect the earth ground (green) wire to the TB7 terminal labeled “GND”.
4. Connect the neutral wire to the TB7 terminal labeled “NEUT”.
5. Connect the hot wire to the TB7 terminal labeled “HOT”.

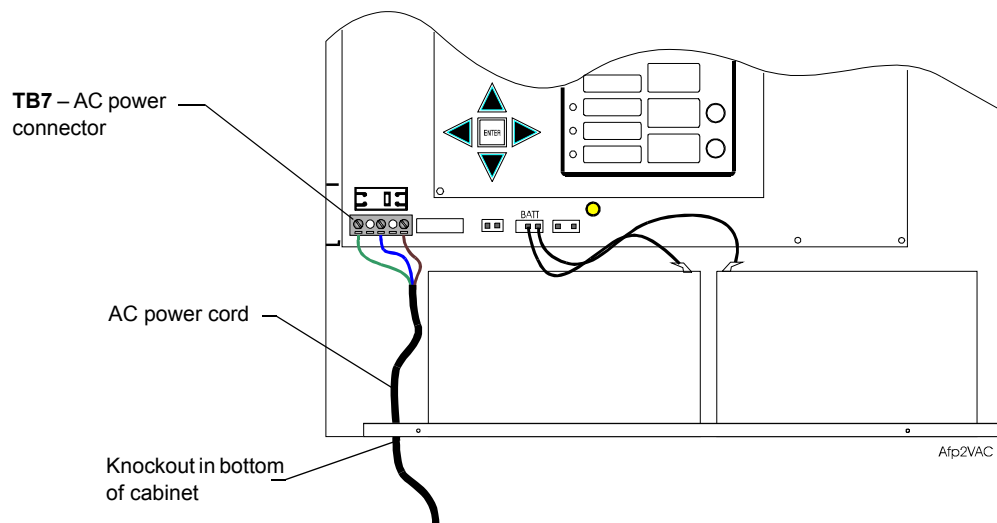

Figure 9 AC Power Connections (TB7)

2.4.2 Battery Power Connection (J3)



WARNING: Battery contains sulfuric acid which can cause severe burns to the skin and eyes, and can destroy fabrics. If contact is made with sulfuric acid, immediately flush skin or eyes with water for 15 minutes and seek immediate medical attention.

Observe polarity when connecting the battery to the control panel. To connect the battery to the control panel, follow these steps:

1. Calculate the battery rating and size required for your installation. For instructions, refer to Appendix A.
2. Connect the battery cable to J3 on the CPU board using the plug-in connector provided.

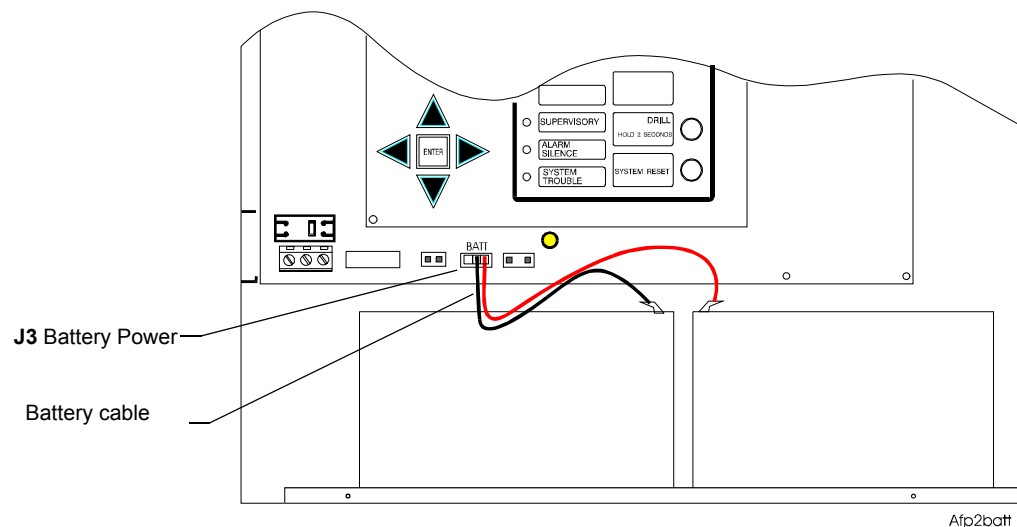

Figure 10 AC and Battery Power Connections

2.4.3 Expansion Power Supplies – AVPS-24 or APS-6R (Optional)

Expansion power supplies can provide additional notification appliance power for Notification Appliance Circuits 3 and 4 (TB2) on the control panel. The control panel can accommodate one of the following expansion power supplies:

- the Audio/Visual Power Supply (AVPS-24); **or**
- the Auxiliary Power Supply (APS-6R).

For detailed information, including installation instructions, refer to Appendix J “Expansion Power Supplies”.

2.5 DC Output Power Connections (TB1)

Figure 11 shows the outputs for DC voltage connections from TB1 on the CPU:

Note: All DC power outputs are power-limited.

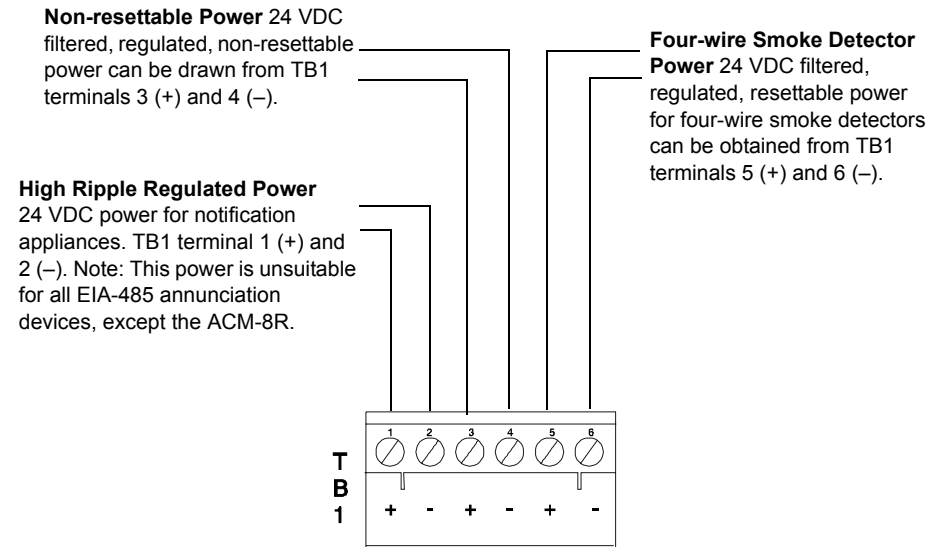

Figure 11 DC Output Power Output Connections

2.6 Output Circuits (TB2)

Output circuits consist of Notification Appliance Circuits (NACs) connected through TB2 on the control panel. When connecting output circuits, note the following:

- Use UL-listed 24 VDC notification appliances only. Refer to the Device Compatibility Document for a list of compatible devices.
- Circuits are supervised and power-limited.

Figure 12 shows typical connections for NACs connected to TB2.

2.6.1 Notification Appliance Circuits

The control panel provides four Notification Appliance Circuits (Style Y). Each NAC can supply up to 2.5 A of current. Total current drawn from these as well as DC power outputs cannot exceed 5.0 A. An additional 3.0 A are available when using an expansion power supply (AVPS-24/AVPS-24E or APS-6R). For details on expansion power supplies, refer to Appendix J “Expansion Power Supplies”.

Note: Notification circuit polarity shown in alarm state.

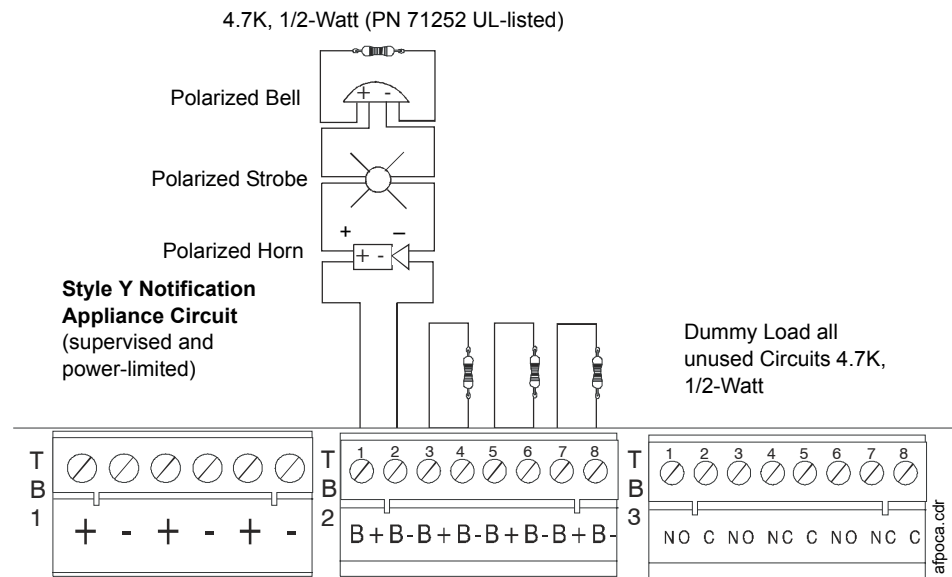

Figure 12 Output Circuit Connections (TB2)

2.7 Standard Relays (TB3)

The control panel provides a set of Form-C alarm and a set of Form-C trouble contacts rated for 2.0 A @ 30 VDC (resistive). The control panel also provides a Form-A supervisory contact rated for 2.0 A @ 30 VDC (resistive).

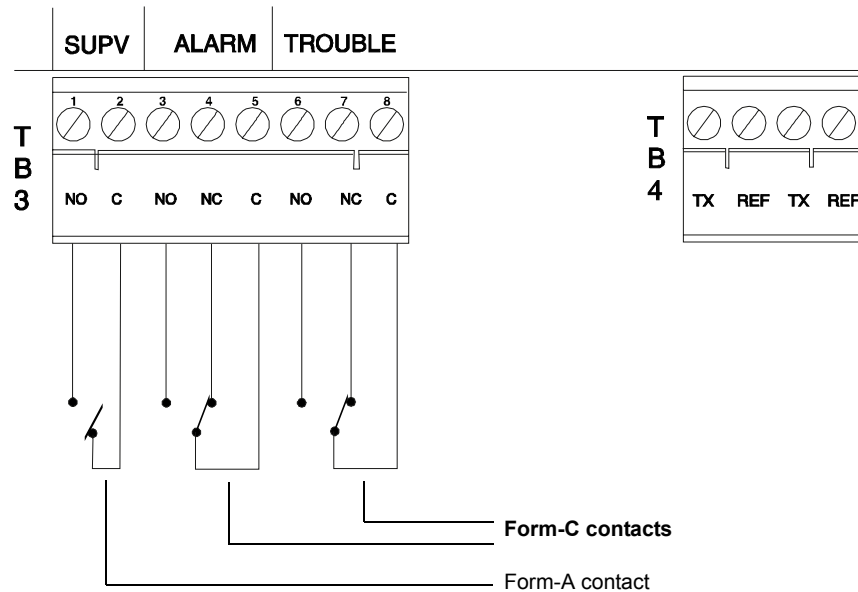

Figure 13 Relay Connections (TB3)

2.8 EIA-232 Devices – Remote Printers and CRTs (TB4)

2.8.1 Overview

The PRN remote printer provides a hardcopy printout of all status changes within the system and time-stamps the printout with the current time and date from the panel. The PRN provides 80 columns of data on standard 9-inch by 11-inch (22.86 cm by 27.94 cm) tractor-feed paper.

2.8.2 Printer Configuration

Refer to the documentation supplied with the PRN for instructions on the printer's menu controls. Set the printer's options as listed in Table 8.

Option	Setting
L/R Adjust	0
Font	Draft
LPI	6 LPI
ESC Character	Esc
Bidirectional Copy	On
CG-Tab	Graphic
Country	E-US ASCII
Auto CR	ON
Color Option	Not installed
Formlen: Lines Standard	6 LIP-60 Executive 10.5
CPI	10 CPI
Skip	0.0"
Emulate	Epson
I/O: Baud Format Protocol	40KB 2400 7 bit, Even, 1 Stop XON/XOFF
Character	Extended
S1. Zero	On
Auto LF	Off
Menlock	All
Paper: Bin 1 Bin 2 Single Pull Tra Pap Roll Paport	12/72" 12/72" 12/72" 12/72" 12/72" No

Table 8 PRN Remote Printer Options

2.8.3 Installation

Remote printers require 120 VAC, 50/60 Hz primary power. A secondary power source (battery backup) is not provided. The use of a separate uninterruptible power supply (UPS), UL-listed for Fire Protective Signaling is recommended.

Connection between the control panel and the PRN is via an EIA-232 interface. A custom cable must be assembled for connection to the printer's EIA-232 port.

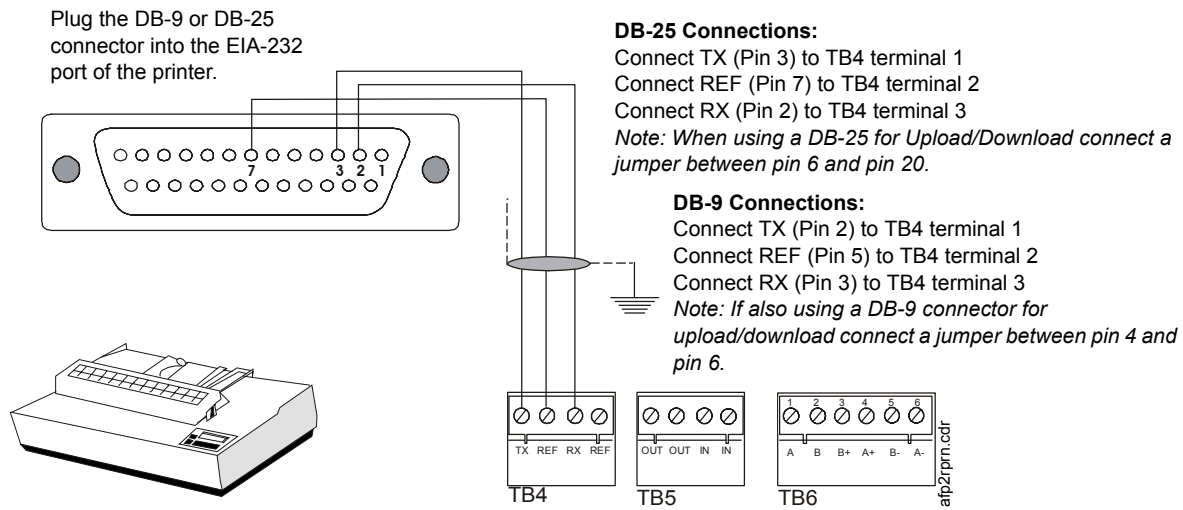

The EIA-232 printer interface may also be used with EDP UL-listed equipment, such as personal computers, to monitor the control panel for supplementary purposes.

Figure 14 Remote Printer Connections

2.8.4 Keltron Printer

Figure 15 shows typical connections between the control panel and a Keltron printer.

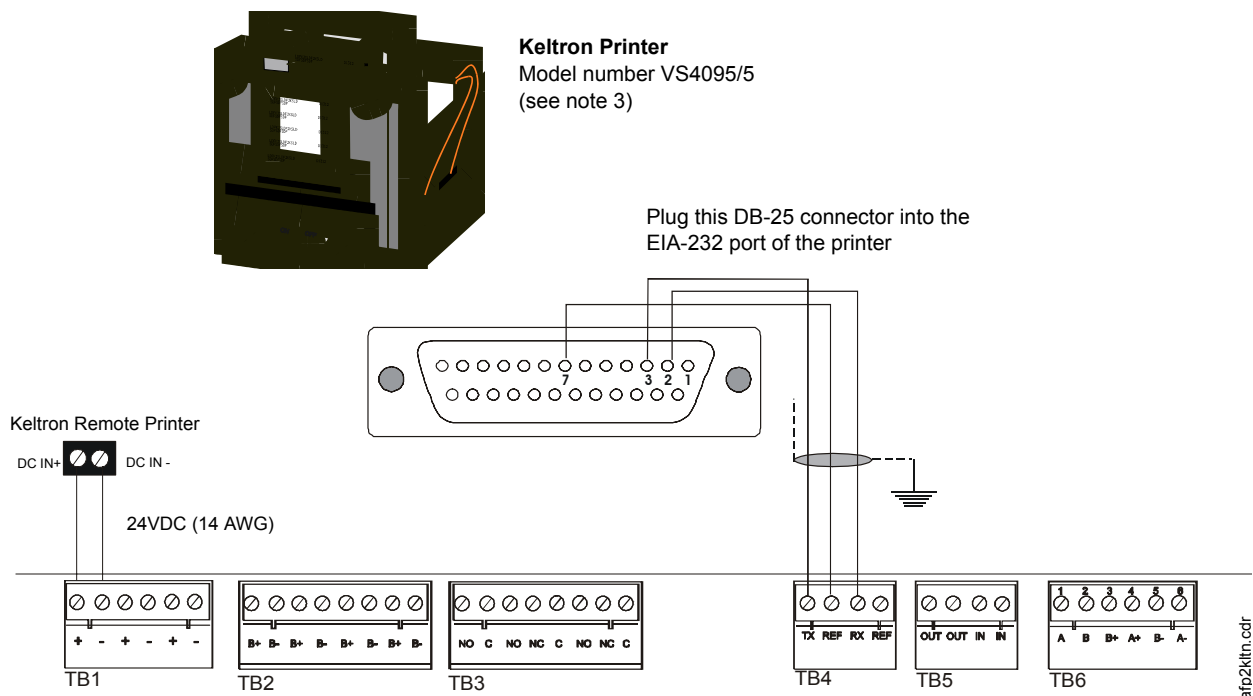

Figure 15 Keltron Printer Connections

Notes on Figure 15:

1. Outputs are power-limited, but are not supervised.
2. Connections must be made with overall foil/braided-shield twisted paired cable

suitable for EIA-232 applications. Typically, 50 feet (15.24 m) is the maximum recommended wiring distance between printer and control panel.

3. The printer communicates using the following protocol:

Baud rate	2400
Parity	Even
Data Bits	Seven
Stop Bits	One

4. Set DIP switches SP1 and SP2 on the Keltron printer as follows:

SP1-1: OFF	SP1-2: ON	SP1-3: OFF	SP1-4: ON	SP1-5: OFF
SP1-7: ON	SP1-8: OFF	SP2-1: OFF	SP2-2: OFF	SP2-3: OFF
SP2-4: OFF	SP2-5: OFF	SP2-7: ON	SP2-8: OFF	

2.8.5 CRT Connections

For terminal interface and protocol information, refer to Appendix I.

This section shows how to connect a CRT to the control panel and how to connect a combination of CRTs and printers (daisy chain). Figure 16 shows typical connections for a CRT to the control panel:

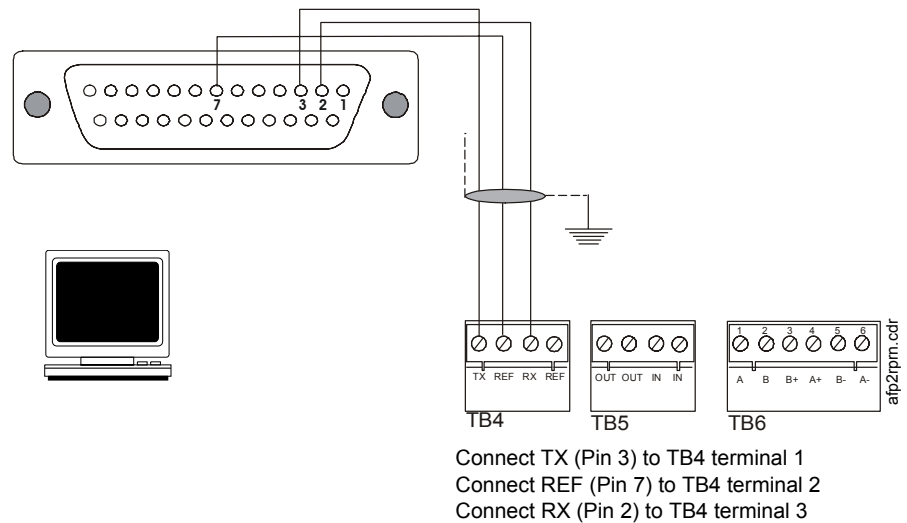
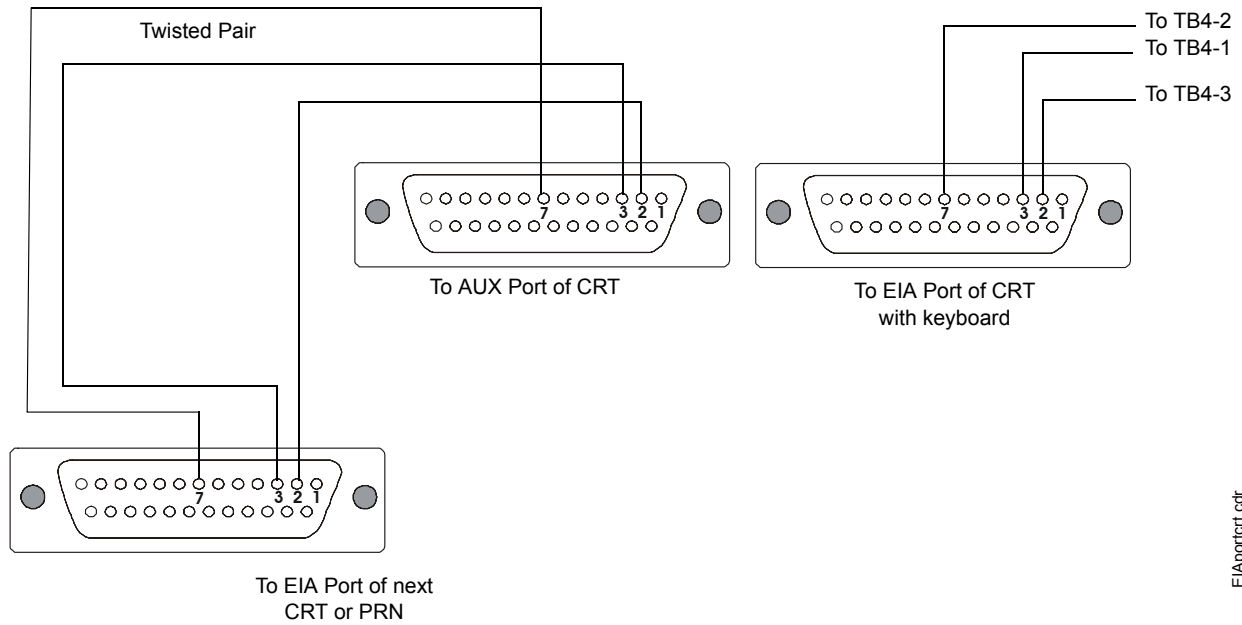

Figure 16 CRT Connections

Figure 17 shows typical connections for daisy chaining multiple CRTs, printers, or both. (Refer to CRT configuration in Appendix I.)



EIAport.txt.cdr

Figure 17 Connections For Multiple CRTs or Combined CRTs and Printers

2.9 Wiring a Signaling Line Circuit (SLC)

2.9.1 Overview of SLC Wiring

Communication between the control panel and intelligent and addressable initiating, monitor, and control devices takes place through a Signaling Line Circuit (SLC). You can wire an SLC to meet the requirements of NFPA Style 4, Style 6, or Style 7 circuits. This section covers the topics outlined in Table 9:

Topics	Refer to
Setting an Address for a monitor, control, or relay module	Figure 22.
Methods for terminating wiring leaving the control panel	"SLC Shield Termination" on page 43.
Wire Requirements for a Two-wire SLC	"Wire Requirements for a Two-wire SLC" on page 45, which covers: <ul style="list-style-type: none"> • Loop resistance for a Two-wire SLC. • Total wiring length for a Two-wire SLC. • Typical Wiring for a Two-wire SLC.
Wire Requirements for a Four-wire SLC	"Wire Requirements for a Four-wire SLC" on page 46, which covers: <ul style="list-style-type: none"> • Loop resistance for a Four-wire SLC. • Total wiring length for a Four-wire SLC. • Typical Wiring for a Four-wire SLC.
Wiring an ISO-X Isolator Module	"Wiring an Isolator Module (ISO-X)" on page 49, which covers: <ul style="list-style-type: none"> • Description of an ISO-X Module • Isolating a Branch of a Two-wire SLC
Wiring a Conventional Initiating Device Circuit (IDC)	"Wiring an IDC with Monitor Modules" on page 50, which covers: <ul style="list-style-type: none"> • Description of Monitor Modules • Wiring a Two-wire or Four-wire IDC.
Wiring Notification Appliance Circuits (NACs)	"SLC Wiring with Control Modules" on page 57, which covers: <ul style="list-style-type: none"> • Description of control/relay modules • Wiring a Relay Module • Wiring a Control Module • Wiring a Two-wire NAC (Style Y) • Wiring a Four-wire NAC (Style Z)
Wiring an Intelligent Detector	"SLC Wiring with an Intelligent Detector" on page 59
Wiring an Addressable Manual Pull Station	"SLC Wiring with an NBG-12LX Addressable Manual Pull Station" on page 60

Table 9 SLC Wiring Topics

2.9.2 SLC Devices

Communication with intelligent and addressable initiating, monitor, and control devices takes place through a Signaling Line Circuit (SLC). You can wire an SLC to meet the requirements of NFPA Style 4, Style 6, or Style 7 circuits. Table 10 contains descriptions of devices connected to an SLC:

Type of Device	SLC Function
Isolator Modules (ISO-X)	Allows a zone of detectors and modules to be electrically isolated from the remainder of the loop, which lets critical loop components function if a circuit fails. ISO-X modules are required for NFPA Style 7 circuits.
Addressable Monitor Modules	Allows the control panel to monitor entire circuits of conventional alarm-initiating devices, such as manual pull stations, detectors, waterflow and supervisory devices.
Control Modules	Allows the control panel to selectively activate Notification Appliance Circuits (NACs).
Relay Modules	Allows the control panel to selectively activate Form-C output relays.
XP5-M	Allows the control panel to monitor up to five Initiating Device Circuits (IDCs). Each XP5-M occupies five consecutive addresses on the SLC.
XP5-C	Allows the control panel to control a maximum of five individual notification appliance/telephone circuits or Form-C relays. Each XP5-C occupies five consecutive addresses on the SLC.
Intelligent Detectors	Allows the control panel to communicate with intelligent ionization, photoelectric, and thermal detectors on the SLC.
Addressable Pull Station	The NBG-12LX provides a manual method of creating an alarm activation.

Table 10 SLC Devices

Maximum wiring distance of an SLC:

- **Style 4.** 10,000 ft. (3048 m) (12 AWG)
- **Style 6, 7.** 10,000 ft. (3048 m) (12 AWG) total twisted-pair.

2.9.3 Control Panel Capacity

Refer to the installation drawings supplied with each loop device for rating and specification information.

AFP-200 capacity includes up to 99 intelligent detectors and an additional combination of up to 99 addressable pull stations, and monitor, control and relay modules. In addition, the control panel also supports four Notification Appliance Circuits and up to 99 programmable relays.

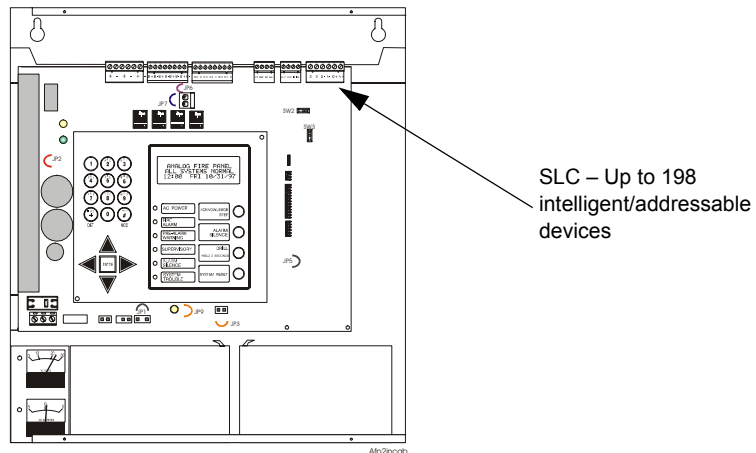

Figure 18 AFP-200 Capacity

2.9.4 SLC Performance

SLC performance depends on the type of circuit: Style 4, Style 6, or Style 7. Table 11 lists the trouble conditions that result when a fault exists on an SLC.

Fault in SLC	Style 4	Style 6	Style 7
Open	Trouble	Alarm/Trouble	Alarm/Trouble
Ground	Alarm/Trouble	Alarm /Trouble	Alarm/Trouble
Short	Trouble	Trouble	Alarm/Trouble
Short and open	Trouble	Trouble	Trouble
Short and ground	Trouble	Trouble	Alarm/Trouble
Open and ground	Trouble	Alarm /Trouble	Alarm/Trouble
Communications loss	Trouble	Trouble	Trouble

- **Trouble** indicates a trouble signal will be generated at the control panel during the abnormal condition.
- **Alarm/Trouble** indicates an alarm signal can be transmitted to the control panel during the abnormal condition.
- SLC operation meeting Style 7 requirements isolates entire physical zones on the SLC from faults that occur within other areas of the SLC.

Table 11 SLC Performance

2.9.5 SLC Shield Termination

Overview

All wiring leaving the control panel must be shielded. Figure 19, Figure 20, and Figure 21 show three methods of wiring termination, depending on the type of conduit used: a) no-conduit, b) full-conduit, and c) partial-conduit.

No-Conduit Shield Termination

Do not allow the shield drain wire to enter the system cabinet. Connect the drain wire to the outside of the cabinet using a cable connector as shown in Figure 19:

Scrape paint away from the cabinet to make good electrical connections.

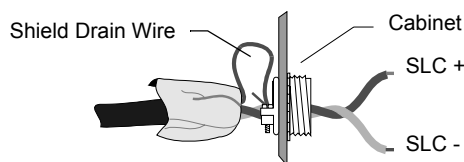

shield1.wmf

Figure 19 Shield Termination – No Conduit

Full-Conduit Shield Termination

For Style 6 or Style 7 field-wiring of the SLC, connect each end of the shield to the negative side of the respective channel as shown in Figure 20:

The shield drain wire must be connected to the negative (-) side of the loop. Do not let the shield drain wire or the shield foil touch the system cabinet.

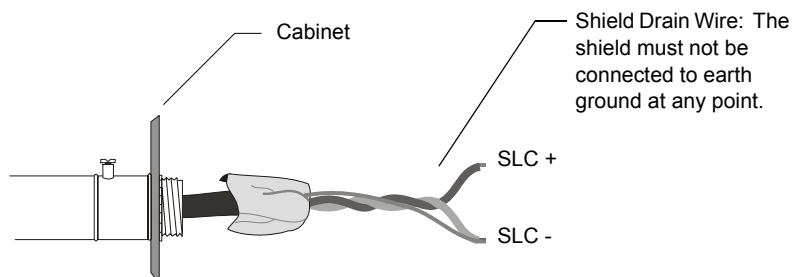

shield2.wmf

Figure 20 Shield Termination – Full Conduit

Partial-Conduit Shield Termination

Do not allow the shield drain wire to enter the system cabinet or the conduit. Connect the drain wire to the termination point of the conduit run.

If the length of conduit from the control panel cabinet exceeds 20 feet (6.096 m), terminate the shield as shown. If using a metal box, you must use a metal conduit.

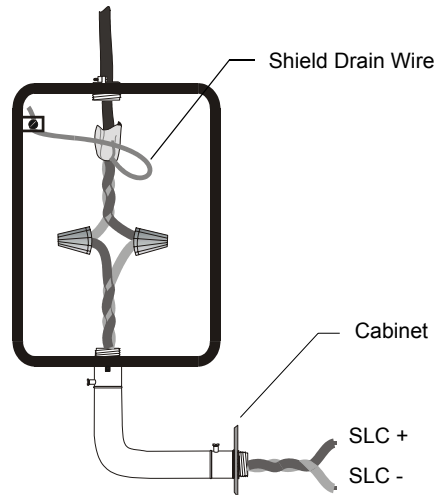

Figure 21 Shield Termination – Partial Conduit

2.9.6 Setting an SLC Address for a Module

Each module can be set to one of 99 addresses (01-99) and is factory preset with an address of “00”. Addresses past 99 are not recognized by this system.

To set an SLC address, use a common screwdriver to adjust the rotary switches on the module to the desired address. The unit below is set at “35”. When finished, mark the address on the module face in the place provided.

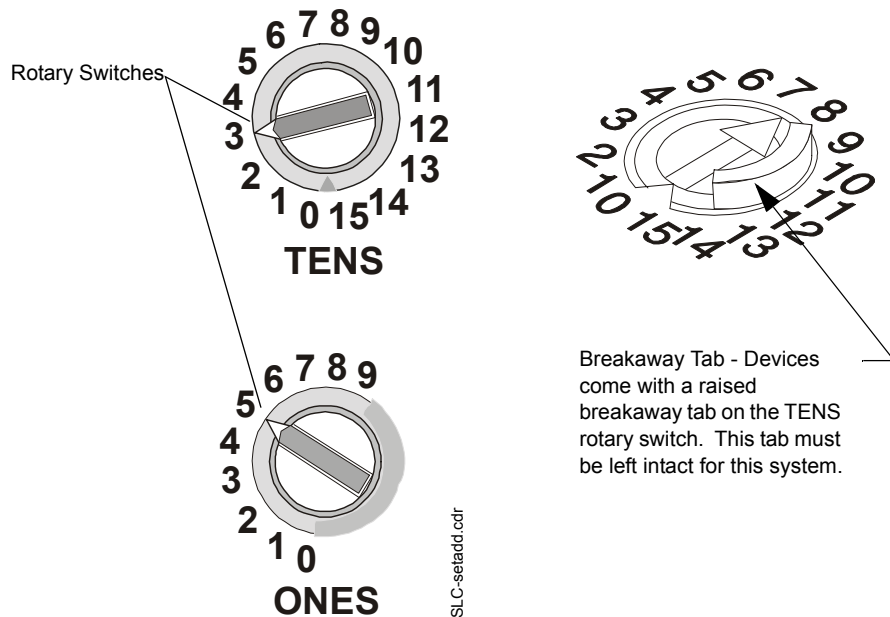

Figure 22 Setting SLC Address on Module

2.9.7 Wire Requirements for a Two-wire SLC

Measuring Loop Resistance for a Two-wire SLC

The total DC resistance from panel to branch end cannot exceed 40 ohms. Measure DC resistance as shown in Figure 23:

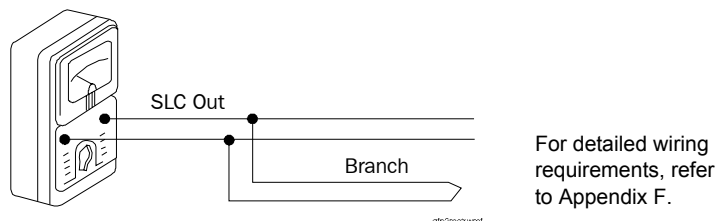

Figure 23 Measuring DC Resistance of a Two-wire SLC

1. Short the termination point of one branch at a time. Measure the DC resistance from the beginning of the loop to the end of that particular branch.
2. Repeat this procedure for all remaining branches in the SLC.

Measuring Total Wire Length for a Two-wire SLC

The total length of wire (12 AWG) in a two-wire SLC cannot exceed 10,000 feet (3048 m). Find the total length of wire in the SLC by summing the wire lengths on each branch of the SLC. Figure 24 shows how to find the total length wire in a typical two-wire SLC.



CAUTION: Terminate shield drain wire according to the instructions in “SLC Shield Termination” on page 43.

$$\begin{array}{l}
 \text{(Branch A)} \\
 + \text{(Branch B)} \\
 + \text{(Branch C)} \\
 + \text{(Branch D)} \\
 + \text{(Branch E)} \\
 \hline
 = 10,000 \text{ feet (3048 m) or less} \\
 \text{(12 AWG)}
 \end{array}$$

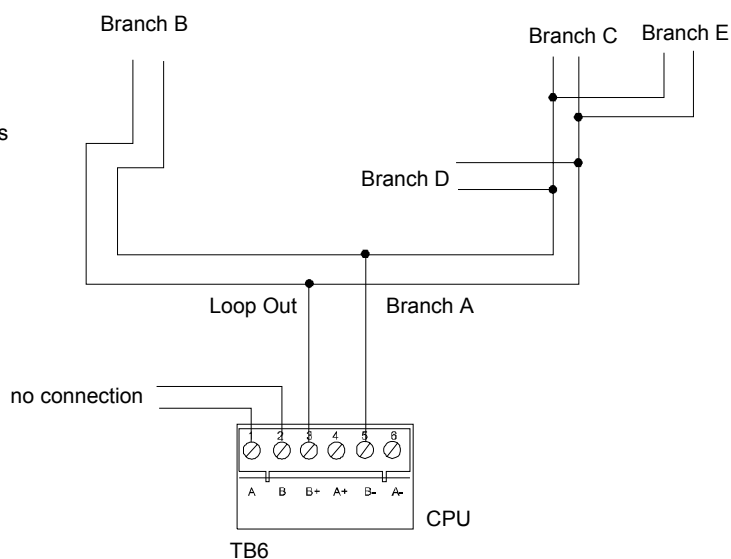

Figure 24 Measuring the Total Length of Wire in a Two-wire SLC

2.9.8 Wire Requirements for a Four-wire SLC

Measuring Loop Resistance for a Four-wire SLC

The total DC resistance of the SLC pair cannot exceed 40 ohms. Measure DC resistance as shown in Figure 25. For detailed UL wiring requirements, refer to Appendix F.

1. Disconnect the SLC Out and SLC Return at the control panel.
2. Short the two leads of SLC Return.
3. Measure the resistance across the SLC Out leads (Figure 25).

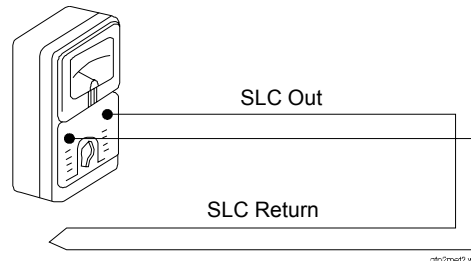

Figure 25 Meter Leads for Measuring a Four-wire SLC

Measuring Total Wire Length for a Four-wire SLC

The total length of wire (12 AWG) in a four-wire SLC cannot exceed 10,000 feet (3048 m). Figure 26 identifies the output and return loops from SLC terminal TB5 on the CPU:

T-Tapping is not allowed on a four-wire SLC.

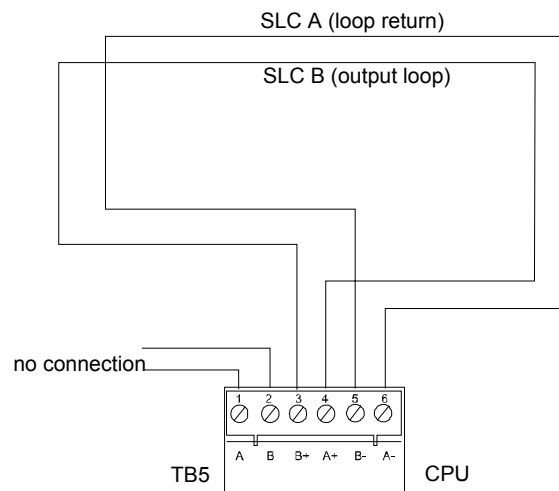

Figure 26 Measuring the Wire Length – Four-wire SLC

Figure 27 shows typical wiring of a supervised and power-limited two-wire SLC that meets NFPA 72 Style 4 requirements.



CAUTION: Terminate shield drain wire according to the instructions in “SLC Shield Termination” on page 43.

Note: ISO-X devices are not required to meet NFPA Style 4. You can install a maximum of 25 devices, detectors, and modules between isolator modules, or isolator detector mounting base.

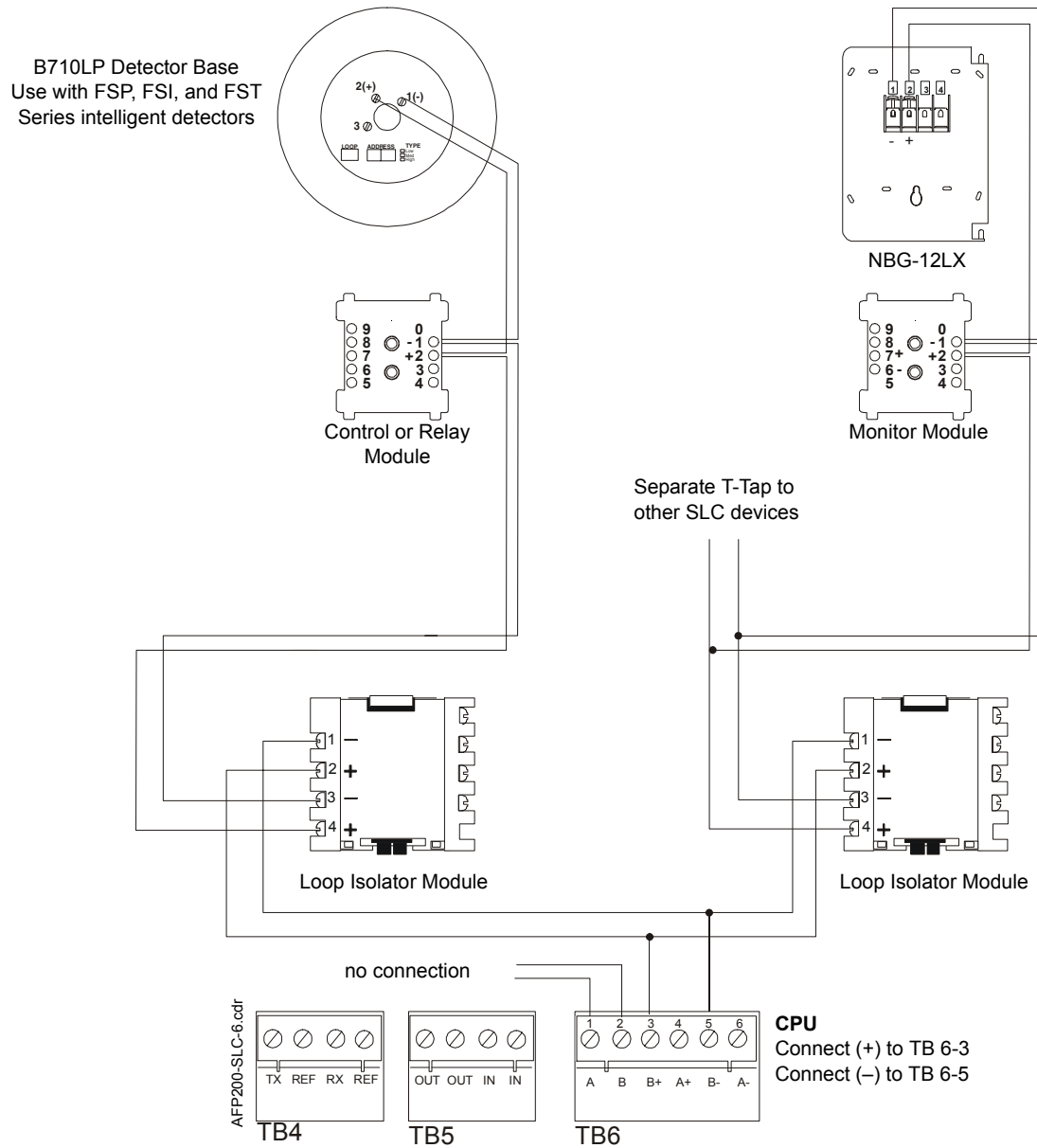

Figure 27 Two-wire SLC (Style 4)

Figure 28 shows typical wiring for a supervised and power-limited four-wire SLC that meets NFPA 72 Style 6 requirements.



CAUTION: Terminate shield drain wire according to the instructions in “SLC Shield Termination” on page 43.

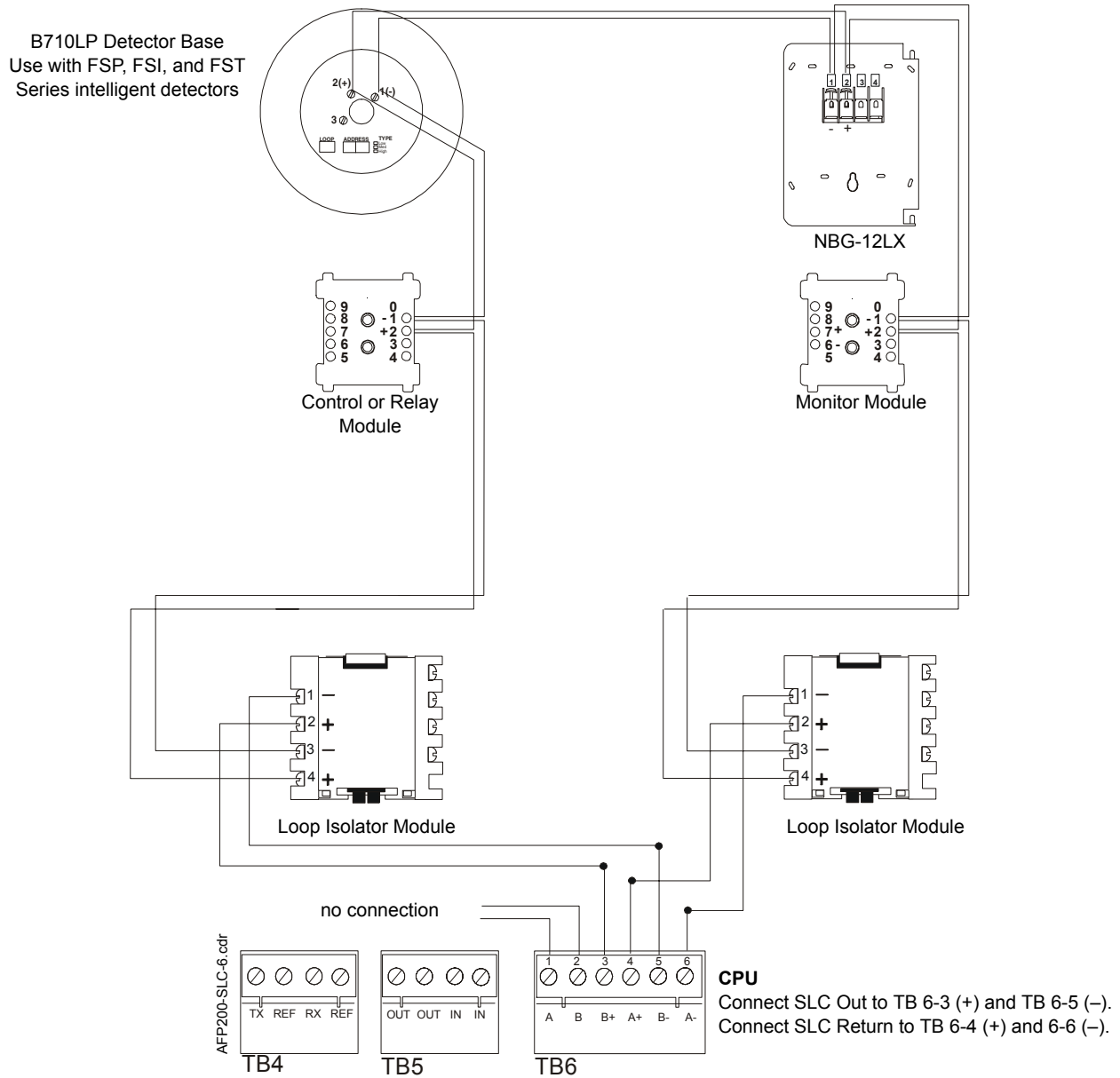

Figure 28 Typical Four-wire SLC Circuit (Style 6)

Style 7 Wiring Overview

Figure 29 shows typical wiring of a four-wire SLC that meet NFPA Style 7 requirements. As shown in Figure 29, flanking each SLC device with a pair of ISO-X isolator modules protects each device from short circuit faults that may occur on other SLC devices. For example, a fault on zone 2 will not affect zones 1 and 3. ISO-X modules on either side of zone 2 will open the SLC. Zone 1 will still operate from power on loop out and zone 3 will operate from SLC return. Because the control panel cannot communicate with zone 2, a trouble signal(s) will be generated for that device.

Note: Do not T-Tap or branch a Style 7 four-wire SLC. Ratings and characteristics are identical to a NFPA Style 6 four-wire SLC.

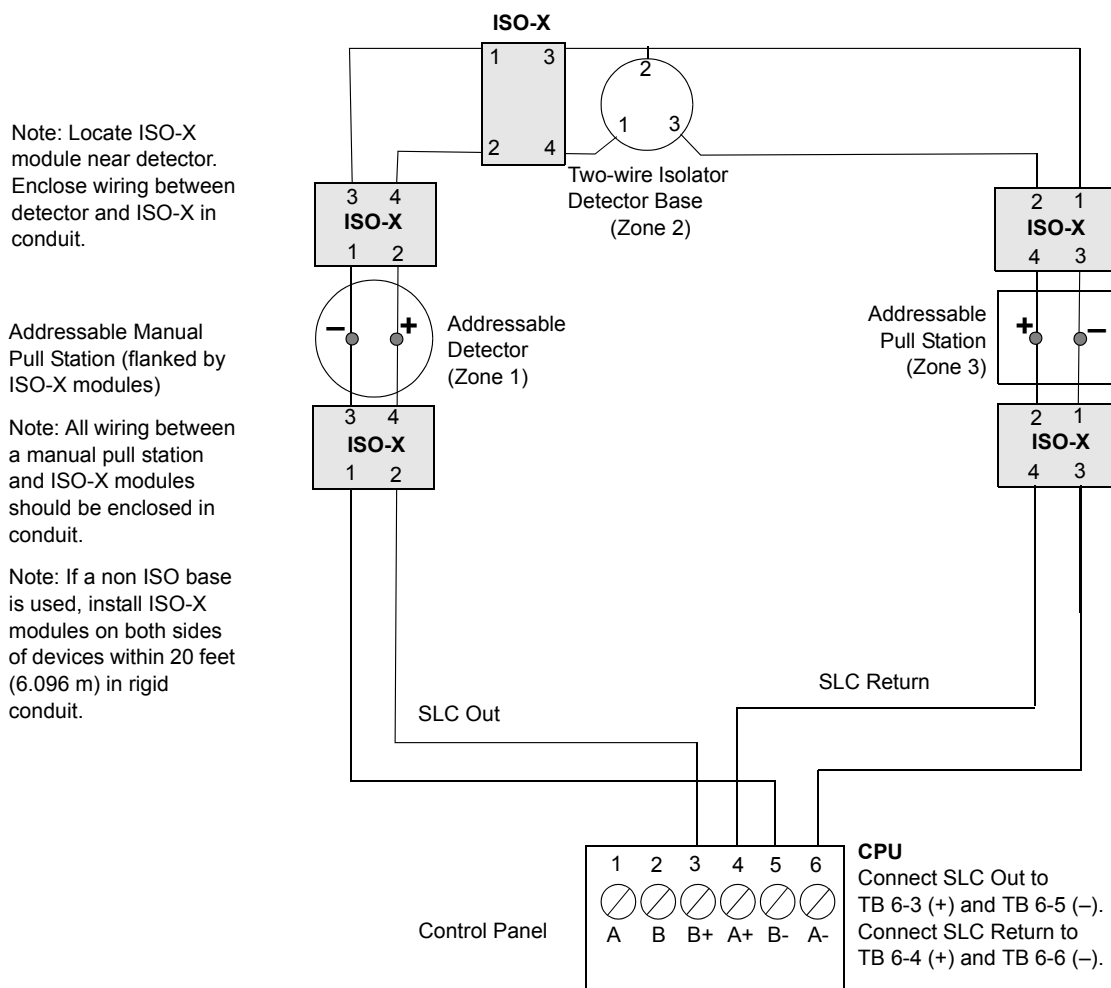

Figure 29 Four-wire SLC (Style 7)

2.9.9 Wiring an Isolator Module (ISO-X)

ISO-X Module Overview

You can connect a maximum of 25 devices between isolator modules. During a fault condition, the control panel registers a trouble condition for each addressable device which is isolated on the SLC segment or branch.

Refer to 2.9.6 “Setting an SLC Address for a Module” for instructions on addressing the modules.

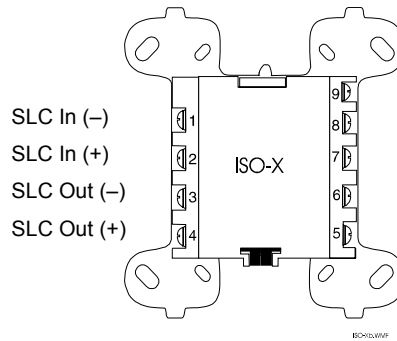

Figure 30 ISO-X Module Terminal Connections

Isolating a Branch of a Two-wire SLC

A short circuit on the SLC Style 4 branch (connected to ISO-X terminals 3 and 4) causes the branch to be disconnected and isolated from the remainder of the SLC. This prevents a communication problem with all other addressable devices on the branches (labeled “Continuation of the SLC” in Figure 31) and all addressable devices on the isolated branch will report a trouble condition at the CPU.

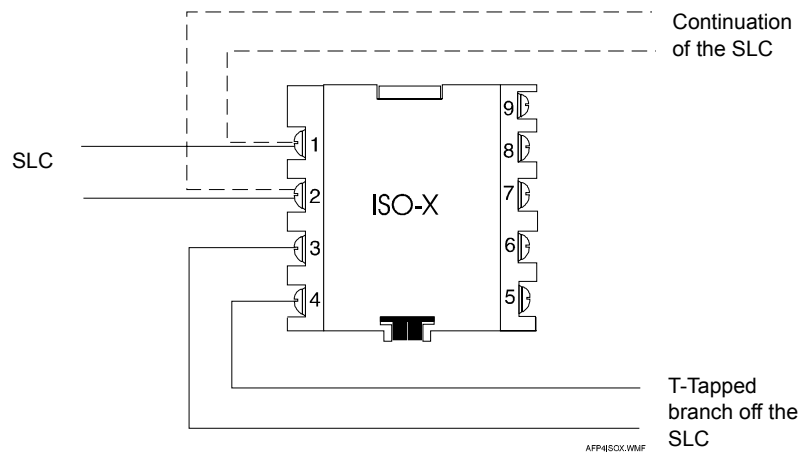

Figure 31 Wiring an ISO-X (Style 4)

2.9.10 Wiring an IDC with Monitor Modules

Overview of Monitor Modules

The FMM-1, FZM-1, and FMM-1 Monitor Modules are addressable modules that monitor conventional contact-type, alarm, supervisory, security, alert, or trouble initiating devices. You can wire a supervised monitor-module circuit as an NFPA Style B or Style D Initiating Device Circuit (refer to Figure 34 and Figure 35 for Style B; refer to Figure 36 and Figure 37 for Style D).

Refer to 2.9.6 “Setting an SLC Address for a Module” for instructions on addressing the modules.

- **FMM-1.** Use for wiring Style B and Style D IDCs.
- **FZM-1.** The FZM-1 Monitor Module is an addressable module used to monitor a single Initiating Device Circuit of smoke detectors. Use FZM-1 modules to monitor conventional, two-wire smoke detectors. The FZM-1 requires an

additional connection of 24 VDC filtered, low-noise and resettable power on FZM-1 Terminals 3 (-) and 4 (+).

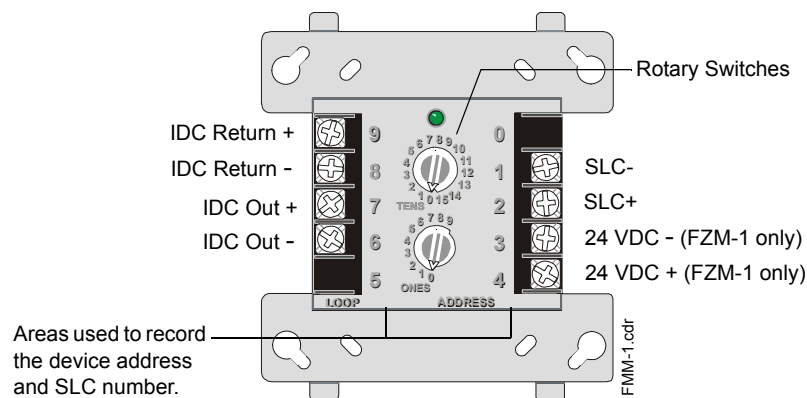

Figure 32 Standard Monitor Module (FMM-1) and Two-wire Detector Module (FZM-1)

- FMM-101 (Style B circuits only).** The FMM-101 is a miniature addressable module that is functionally and electrically identical to an FMM-1 module. Because of the smaller size, an FMM-101 is suitable for mounting directly in the electrical box of a monitored contact-type device.

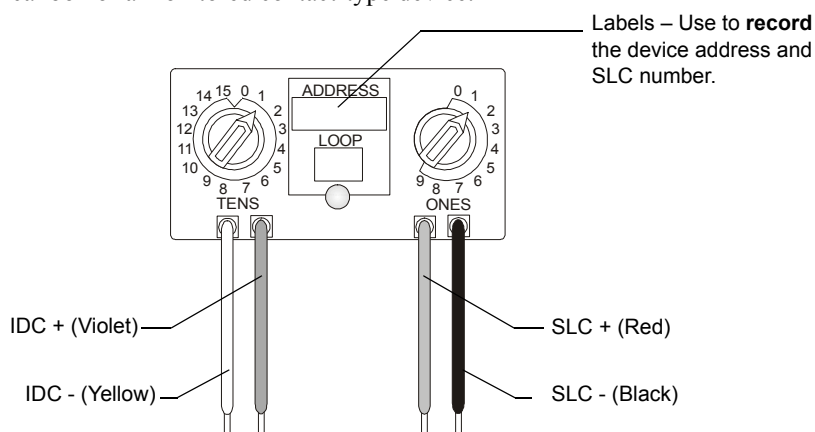

Figure 33 Miniature Monitor Module (FMM-101)

Wiring a Monitor Module

Connect the SLC wiring to terminals 1 (-) and 2 (+) of FMM-1 and/or FZM-1. SLC wiring on the FMM-101 are the red and black wires identified in Figure 33. The monitor module takes one module address on the SLC.

When installing FMM-1 and FMM-101 modules, note the following:

- With these modules, the IDC provides the following services (do not mix):
 - Fire Alarm Service.
 - Automatic/Manual Waterflow Alarm Service with normally open contact devices.
 - Sprinkler Supervision with normally open contact devices.
 - Security Service.
- Maximum IDC wiring resistance is 20 ohms.

Note: Refer to Installation Document shipped with each two-wire detector monitor module for specific installation notes for this variety of module.

Wiring an NFPA Style B IDC with Standard Monitor Modules

Figure 34 shows typical wiring using FMM-1 modules to wire a Style B IDC. Maximum IDC resistance is 20 ohms. Refer to Device Compatibility Document for detector and power supervision relays.

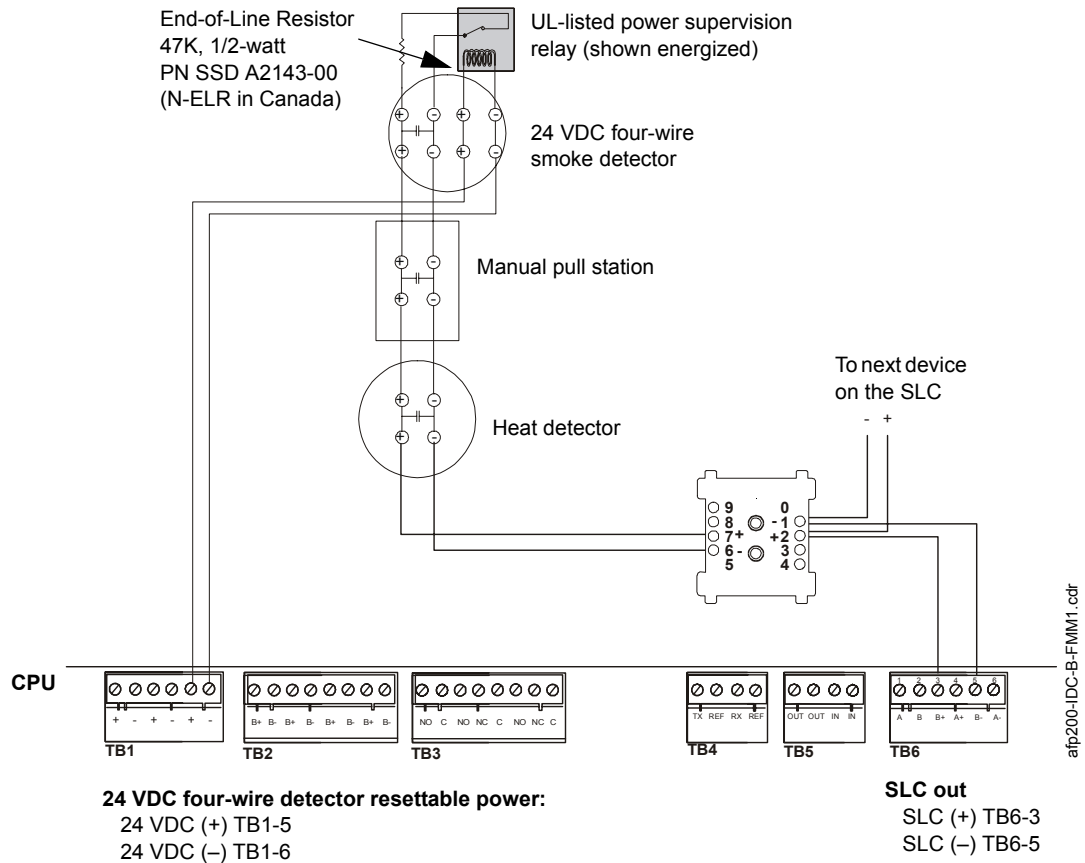

Figure 34 Typical Style B (Class B) IDC Wiring with FMM-1 Modules

Wiring an NFPA Style B IDC with Two-wire Detector Modules

Note: Figure 35 shows typical wiring for a supervised and power-limited NFPA Style B IDC using FZM-1 modules. Refer to Installation Document shipped with each two-wire detector monitor module for specific installation notes for this variety of module.

Wiring guidelines for this IDC are:

Refer to the Device Compatibility Document for detector and power supervision relays.

- Maximum Initiating Device Circuit (IDC) resistance is 25 ohms.
- Maximum alarm current is 90 mA.
- Maximum detector standby current is 2.4 mA.

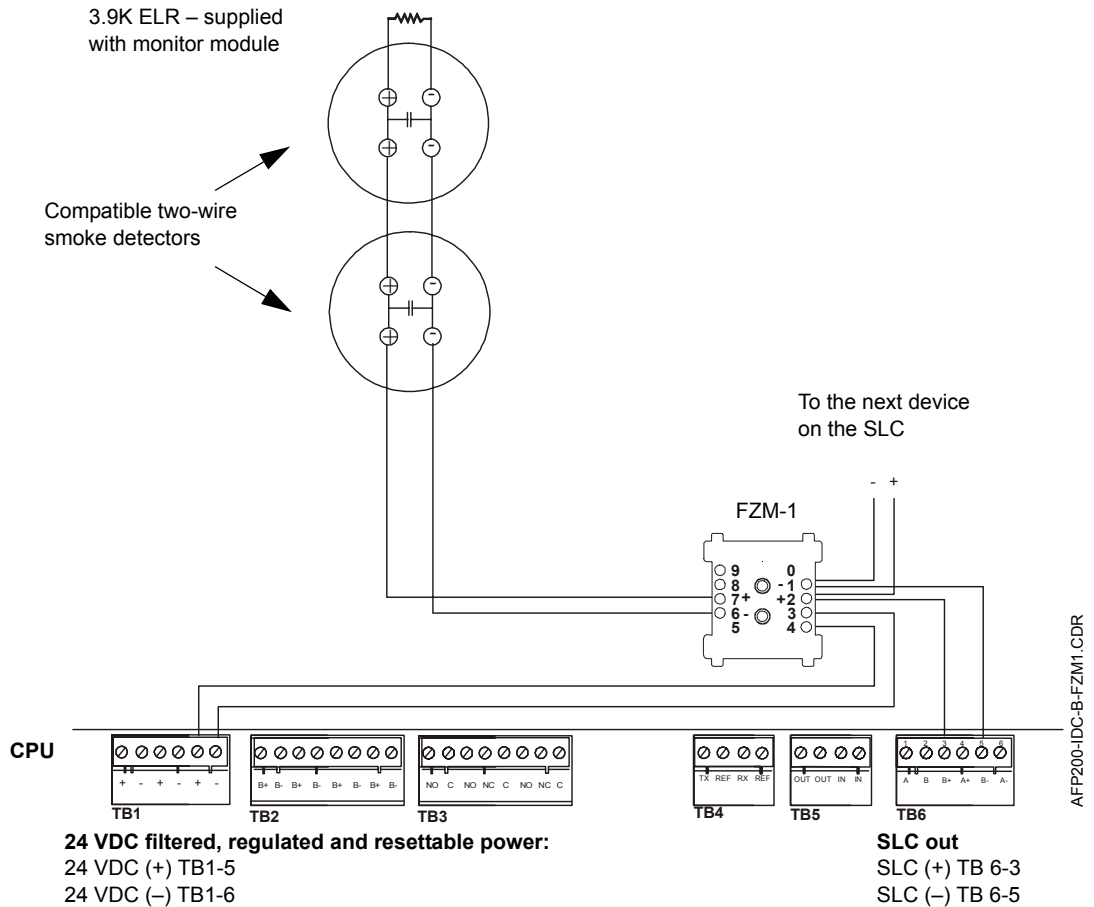

Figure 35 Typical Style B (Class B) IDC Wiring with FZM-1

Wiring an NFPA Style D IDC with Standard Monitor Modules

Figure 36 shows typical wiring for a supervised and power-limited NFPA Style D (Class A) IDC using monitor modules. Maximum IDC resistance is 20 ohms.

Refer to the Device Compatibility Document for detector and power supervision relays.

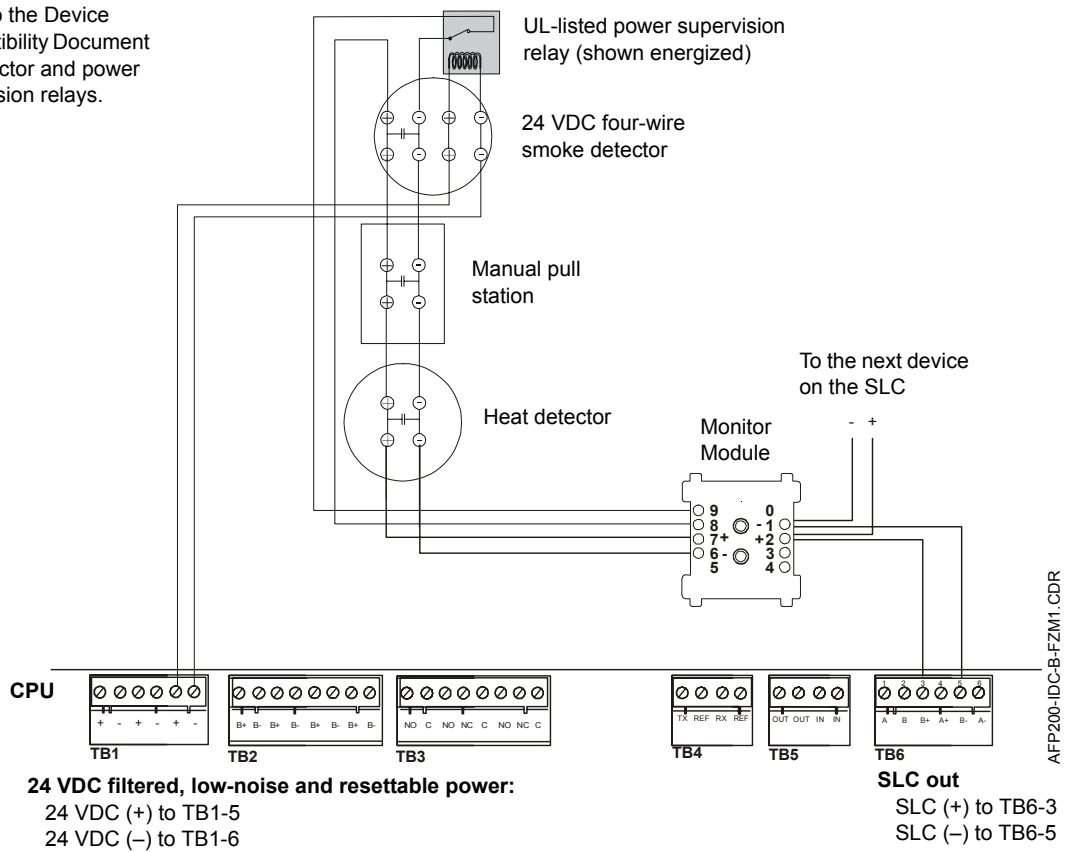

Figure 36 Typical Style D (Class A) IDC Wiring with FMM-1

Wiring an NFPA Style D IDC with FZM-1 Modules

Note: Figure 37 shows typical wiring for a supervised and power-limited NFPA Style D (Class A) IDC using FZM-1 modules. Refer to Installation Document shipped with each two-wire detector monitor module for specific installation notes for this variety of module.

Wiring guidelines for this IDC are:

Refer to the Device Compatibility Document for detector and power supervision relays.

- Maximum Initiating Device Circuit (IDC) resistance is 25 ohms.
- Maximum alarm current is 90 mA.
- Maximum detector standby current is 2.4 mA.

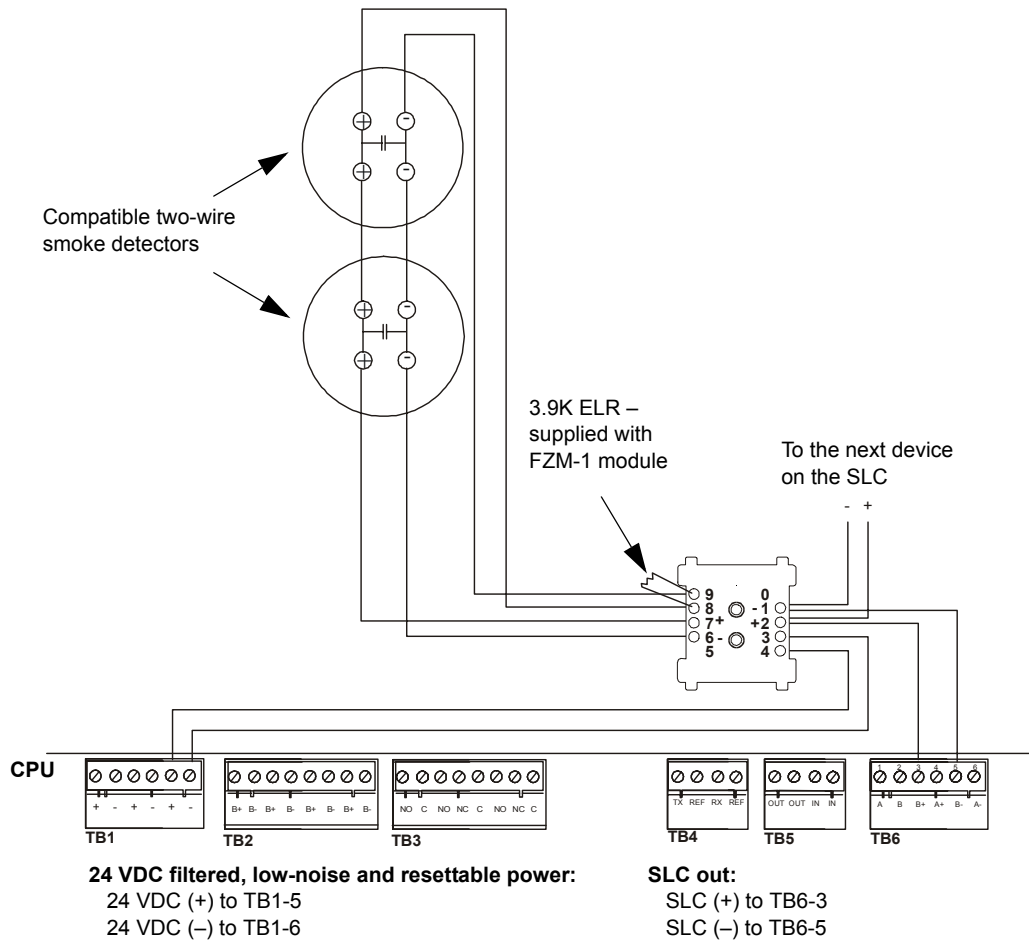

Figure 37 Typical Style D (Class A) IDC Wiring with FZM-1 Modules

2.9.11 Wiring a Notification Appliance Circuit (NAC) or Control Circuit

Control and Relay Module Overview

The FCM-1 is an addressable module that controls a Notification Appliance Circuit (NAC). Use the FCM-1 to route 24 VDC NAC Power for NFPA Style Y (Class B) and NFPA Style Z (Class A) notification circuits. Figure 38 shows control module connections.

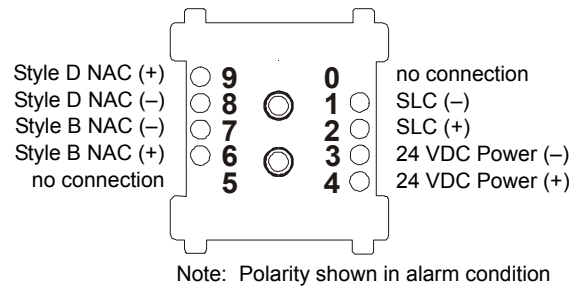

Figure 38 FCM-1 Control Module Connections

The FRM-1 is an addressable module which includes a Form-C dry contact relay which can be used to activate a variety of output circuits. Figure 39 shows relay module connections.

Refer to the installation instruction sheet supplied with the control module for additional information.

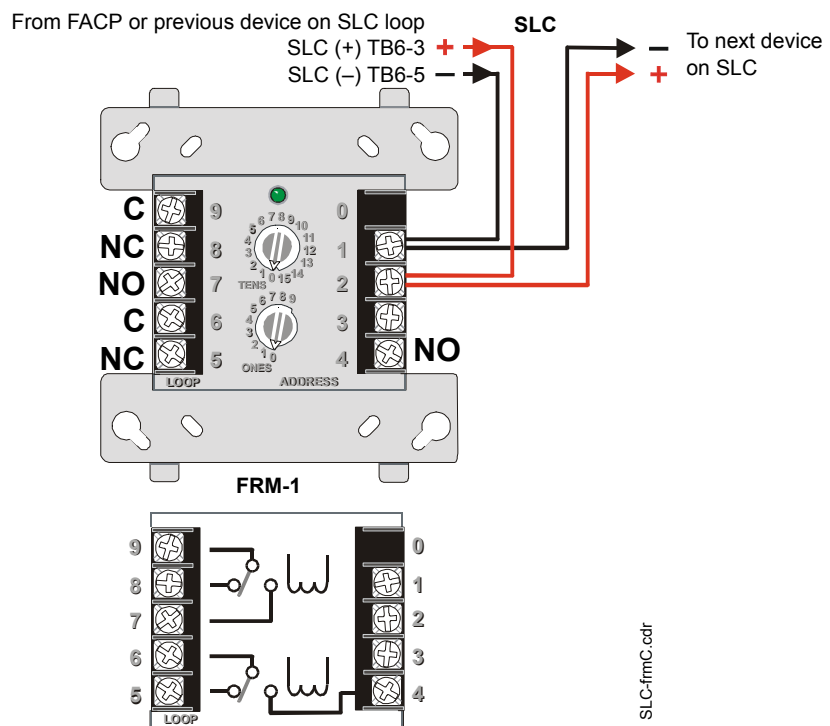

Figure 39 FRM-1 Relay Module Connections

Ratings for the dry contacts on a Form-C relay module are:

Resistive: 3.0 A @ 30 VDC max Non-coded application

Further rating information is available in the module document and data sheet.

Installing a Relay Module

Install a relay module by following the instructions below:

1. Connect the SLC from the CPU to relay module terminals 1 (-) and 2 (+) as shown in Figure 39.
2. Set the rotary switches on the relay module to the required SLC address. (The FRM-1 takes one module address on the SLC. Refer to 2.9.6 “Setting an SLC Address for a Module” for instructions on addressing the modules.)
3. Wire the common and the normally-open or normally-closed contacts to the relay module (Figure 39).

2.9.12 SLC Wiring with Control Modules

This section contains instructions and wiring diagrams for wiring a control module to polarized alarm notification appliances. Figure 40 provides a diagram for two-wire appliances wired according to NFPA Style Y NAC. Figure 41 provides a diagram for four-wire appliances wired according to NFPA Style Z.

Style Y NAC Circuits (Two-wire)

Figure 40 shows a supervised and power-limited NFPA Style Y NAC using a control module. This shows polarized alarm notification appliances connected to control modules in a two-wire configuration. A control module can control 3 A of resistive load (on non-coded electronic devices). Further rating information is available in the module document and data sheet. If installing more than one control module NAC, install the power supervision relay on the 24 VDC power bus after the last control module.

Refer to Device Compatibility Document for compatible notification appliances and relays.

- Do not T-Tap or branch a Style Y circuit.
- Terminate the circuit across the last device using a 47K, 1/2-watt ELR (PN ELR-47K).
- Do not run wiring under any terminals. To maintain supervision, break the wire run.

Wiring Diagram and Instructions

Connect the NAC as follows:

1. Connect the SLC to FCM-1 terminals 1 (-) and 2 (+).
2. Connect 24 VDC power (Figure 40).
3. Set the control module rotary switches to the required SLC address. (The control module takes one module address on the SLC.) Refer to 2.9.6 “Setting an SLC

Address for a Module” for instructions on addressing the modules.

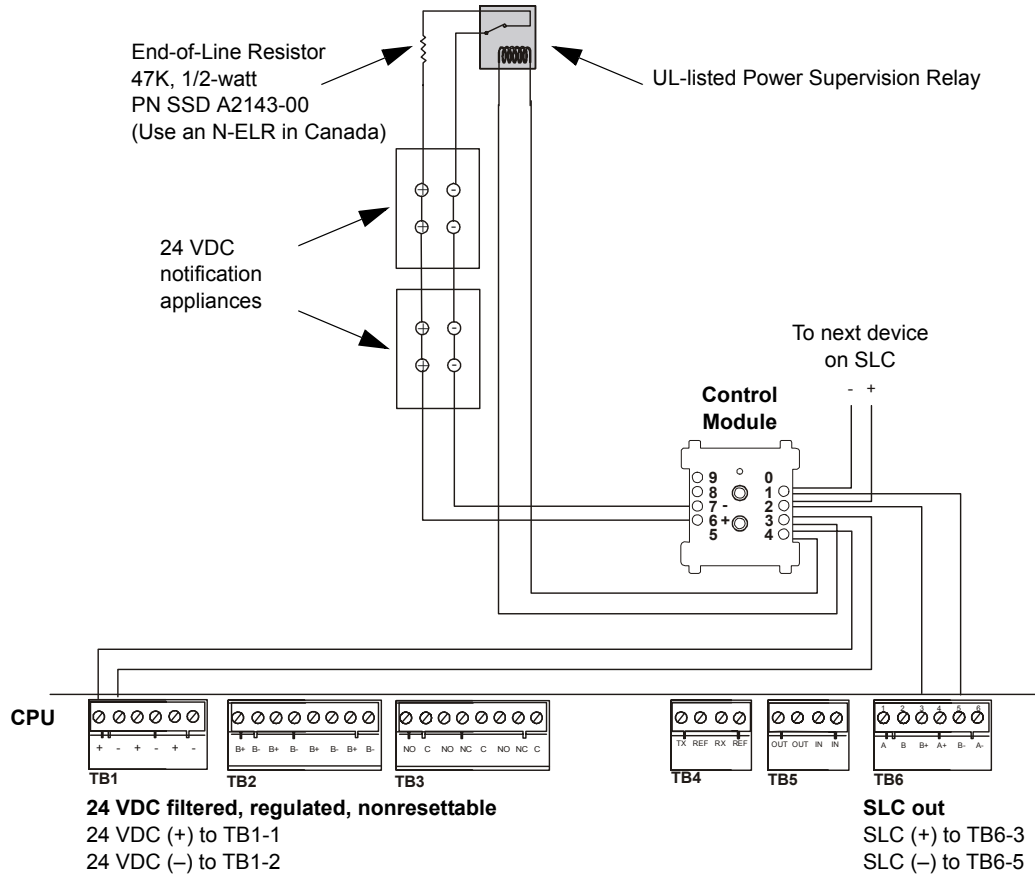

AFP200-NAC-Y-CMXa.cdr

Figure 40 Typical Wiring for an NFPA Style Y NAC

Style Z NAC

Figure 41 shows an NFPA Style Z NAC with notification appliances connected to a control module.

Refer to the Device Compatibility Document for compatible notification appliances.

Connect the NAC as follows:

1. Connect the SLC to control module terminals 1 (-) and 2 (+).
2. Connect 24 VDC power from TB1 to control module terminals 3 and 4.
3. Set the control module rotary switches to the required loop address. (The control module takes one module address on the SLC.) Refer to 2.9.6 “Setting an SLC Address for a Module” for instructions on addressing the modules.

Do not loop wiring under any terminals. Break wire run to maintain supervision. The NAC is supervised and power-limited.

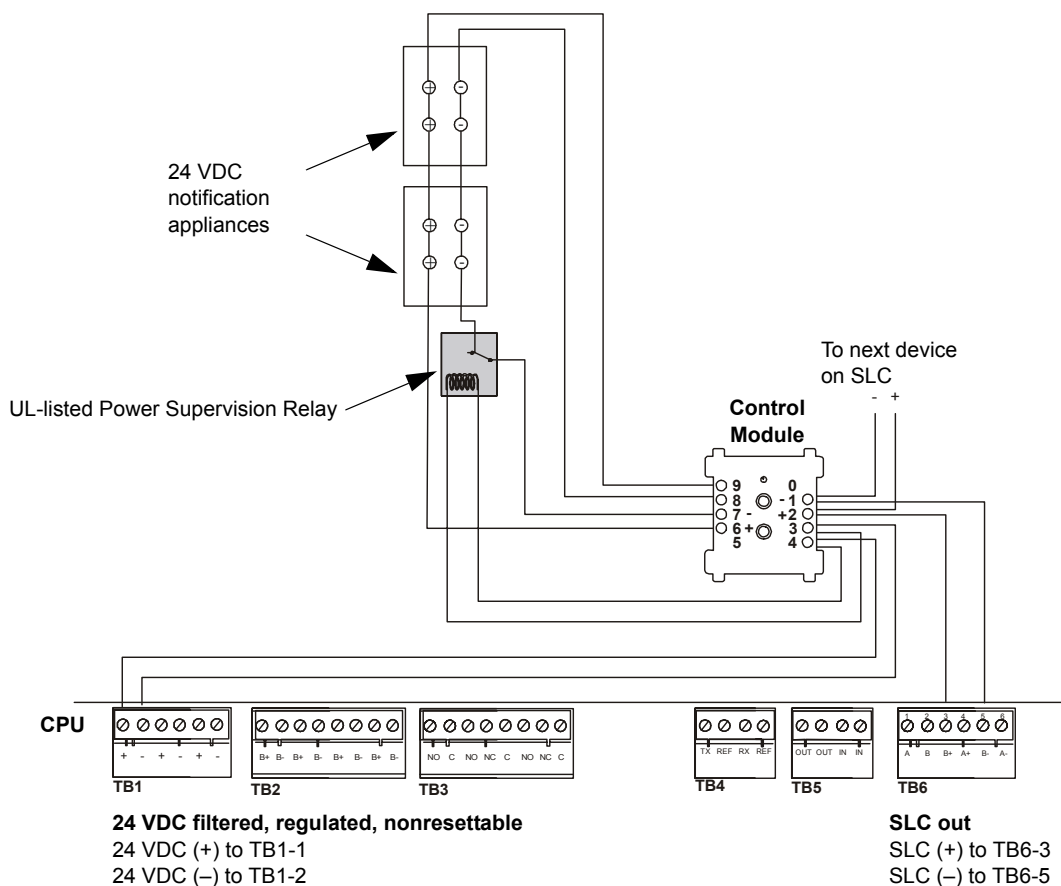

AFP200-NAC-Z-CMIXa.cdr

Figure 41 NFPA Style Z Notification Appliance Circuit

2.9.13 SLC Wiring with an Intelligent Detector

Overview for Wiring Intelligent Detectors

The B501 or B710LP base provides the connection between the SLC and the following intelligent detectors: FSP-751, FSI-751, FST-751, and FST-751R.

1. Connect the communications loop to terminal 1 (-) and terminal 2 (+) on the detector mounting base.
2. If using an RA400Z Remote LED Annunciator: (a) connect the RA400Z positive terminal to base terminal 3; and (b) connect the RA400Z negative terminal to base terminal 1.

3. Set the detector address on the head with a small, slotted screwdriver. Mark this address on the base and on the head.
4. Install the intelligent detector head.

Wiring an Intelligent Detector to an SLC

Figure 42 shows typical wiring of a detector (wired to a RA400Z remote annunciator) connected to an SLC:

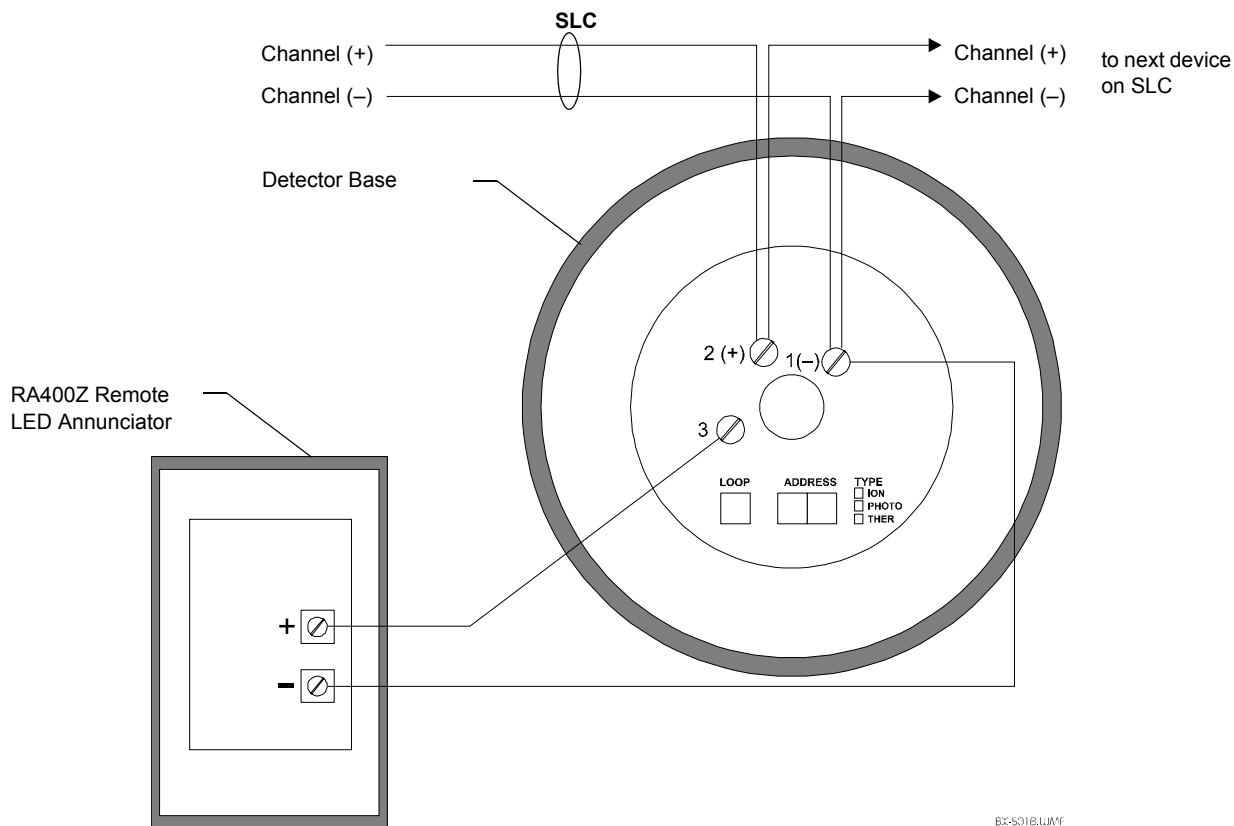

Figure 42 Typical Wiring of a Detector Base to an SLC

2.9.14 SLC Wiring with an NBG-12LX Addressable Manual Pull Station

The NBG-12LX is an addressable manual pull station with a key-lock reset feature. Figure 43 shows typical wiring and provides instructions for setting the SLC address.

1. Connect the SLC to terminal screws (+) and (-).
2. Connect the NBG-12LX to the CPU as shown in Figure 43.
3. Set the SLC address of the pull station. Rotary switches are located on the interior of the pull station, as shown in Figure 43. The address is set the same way as for control, monitor & relay modules (refer to “Setting an SLC Address for a Module” on page 44). Factory preset is address 00. Record the device address and SLC number on the label inside the pull station.

Note: In the sample shown below, the switches are set to address 12.

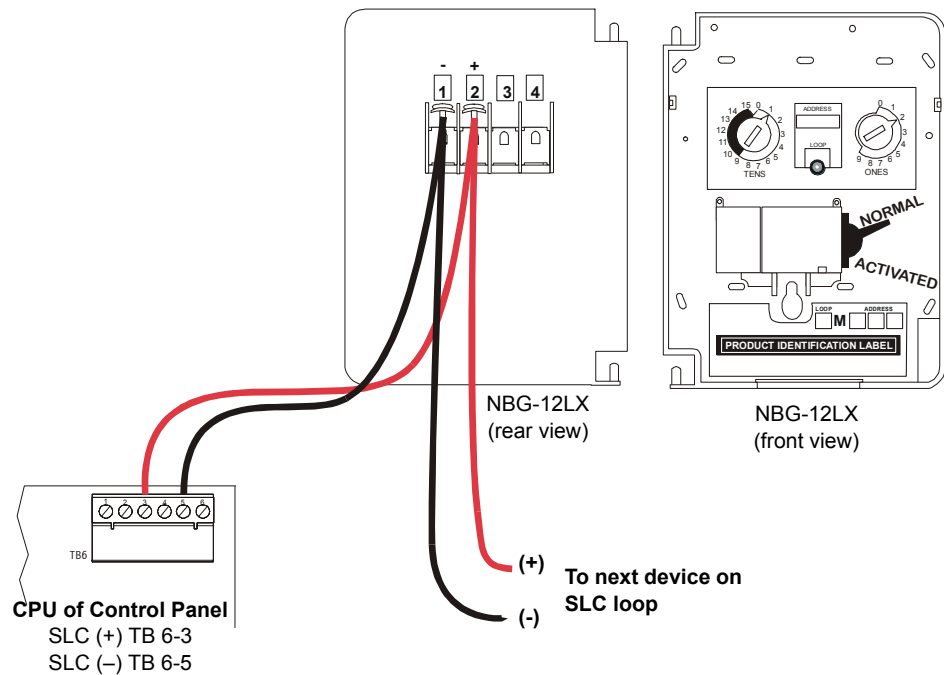

Figure 43 Typical SLC Wiring of an NBG-12LX Pull Station

2.10 Option Module Installation

2.10.1 Overview

The control panel has an option module slot, using connectors J6, J7, and J8 on the CPU board. Two optional modules are available for the control panel: the **4XTM** Transmitter Module and the **RTM-8** Relay Module. To enable module supervision, you must cut jumper JP5 before installing an option module. Figure 44 shows the location of the connectors and jumper JP5.

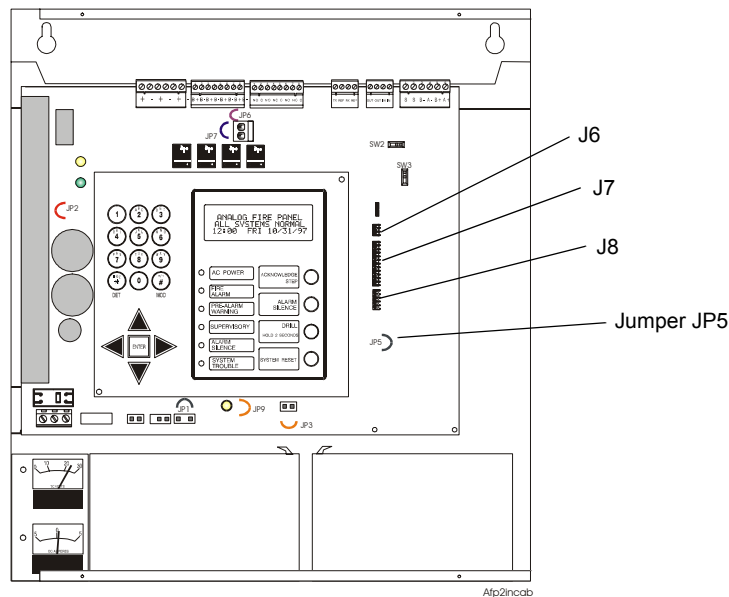
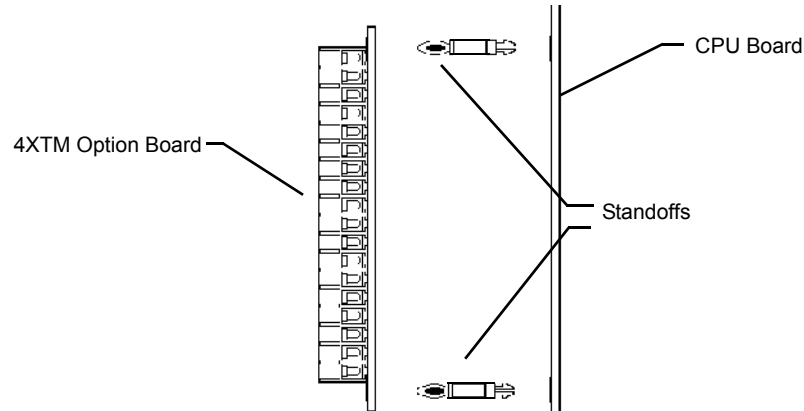

Figure 44 Optional Module Location

2.10.2 Installing a 4XTM Module

Install the 4XTM module onto the CPU board as follows:

1. Insert the two nylon standoffs (provided) into the holes located on the right-side edge of the main circuit board.
2. Carefully align the pins on the circuit board with the connector on the option board; then, press firmly on the option board until it locks in place on the standoffs.
3. Stick the provided labels on the 4XTM module.



4. Push the disconnect switch (Figure 45) down to prevent unwanted activation of the municipal box during testing of the control panel.

The Disconnect LED remains lighted while the municipal box is disconnected. The System Trouble LED will indicate disconnected and/or open circuit conditions on the municipal box. During trouble conditions, it is possible to obtain the circuit condition on the alarm reverse-polarity output. If this operation is desired, cut the TBL jumper (shown in Figure 45)

Figure 45 shows 4XTM module components with polarities shown in activated positions.

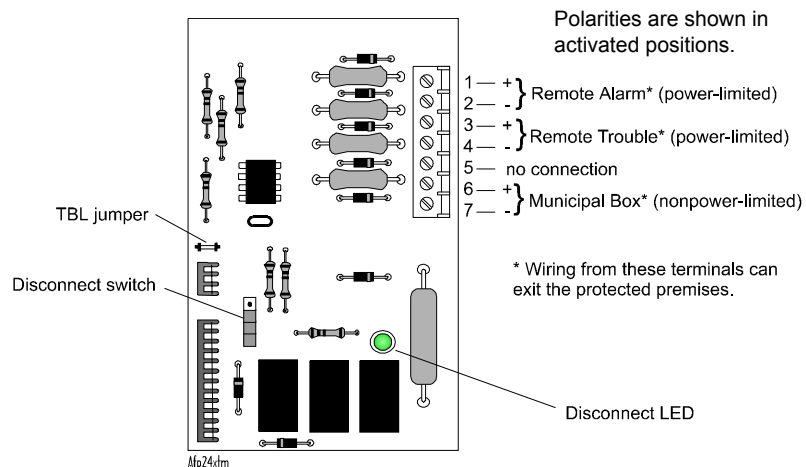

Figure 45 4XTM Module Connections and Components

2.10.3 Installing an RTM-8 Module

Install the RTM-8 module onto the CPU board according to the following directions. If the FACP is in a high vibration area where additional support is desired, install the RTM-8 with a DP-AFP200 Dress Panel, using every step in Figure 46 below. Steps 4 and 8 are not necessary if a dress panel is not installed.

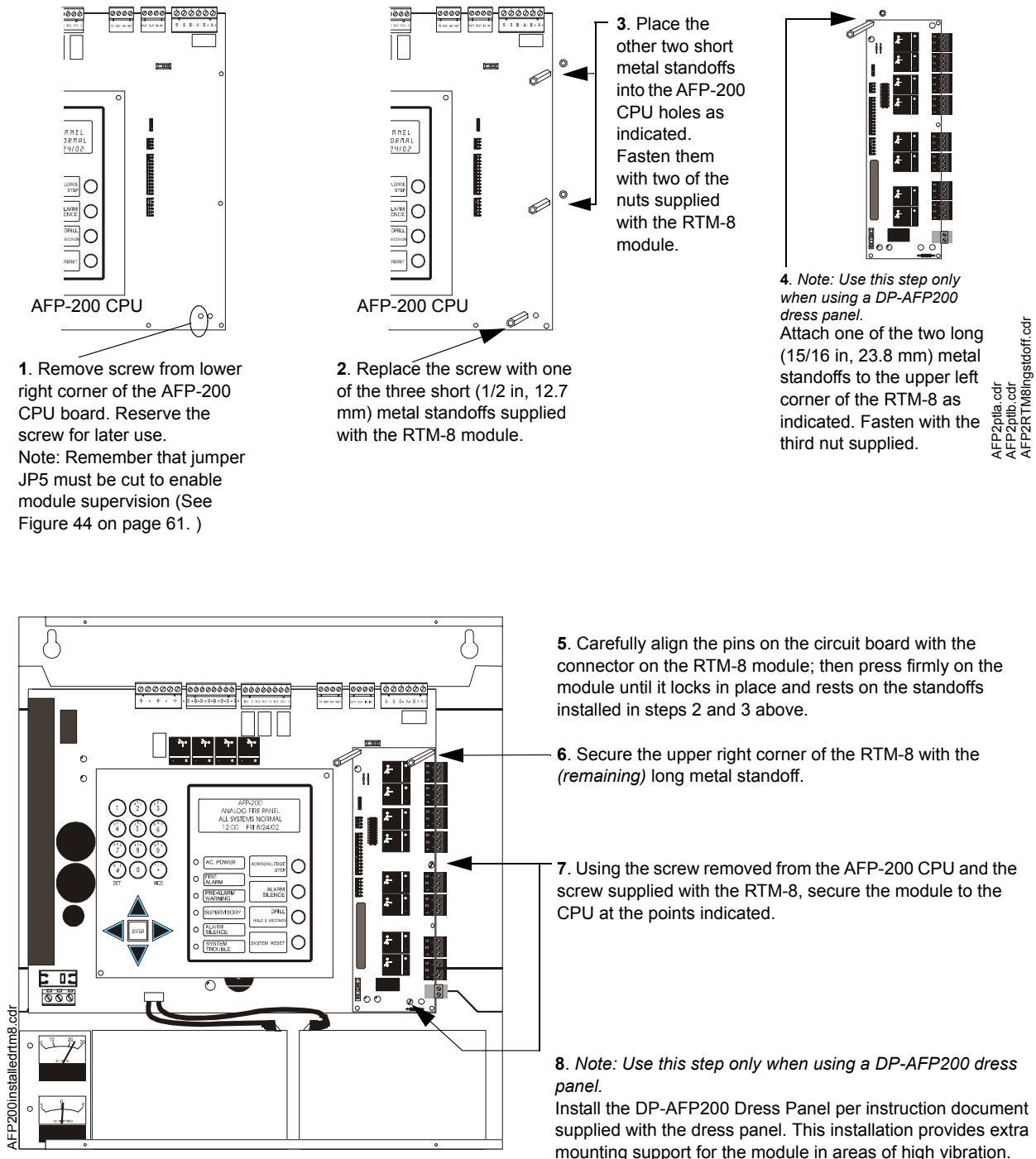

Figure 46 RTM-8 Relay Module Installation

Figure 47 shows electrical connections for the RTM-8 module.

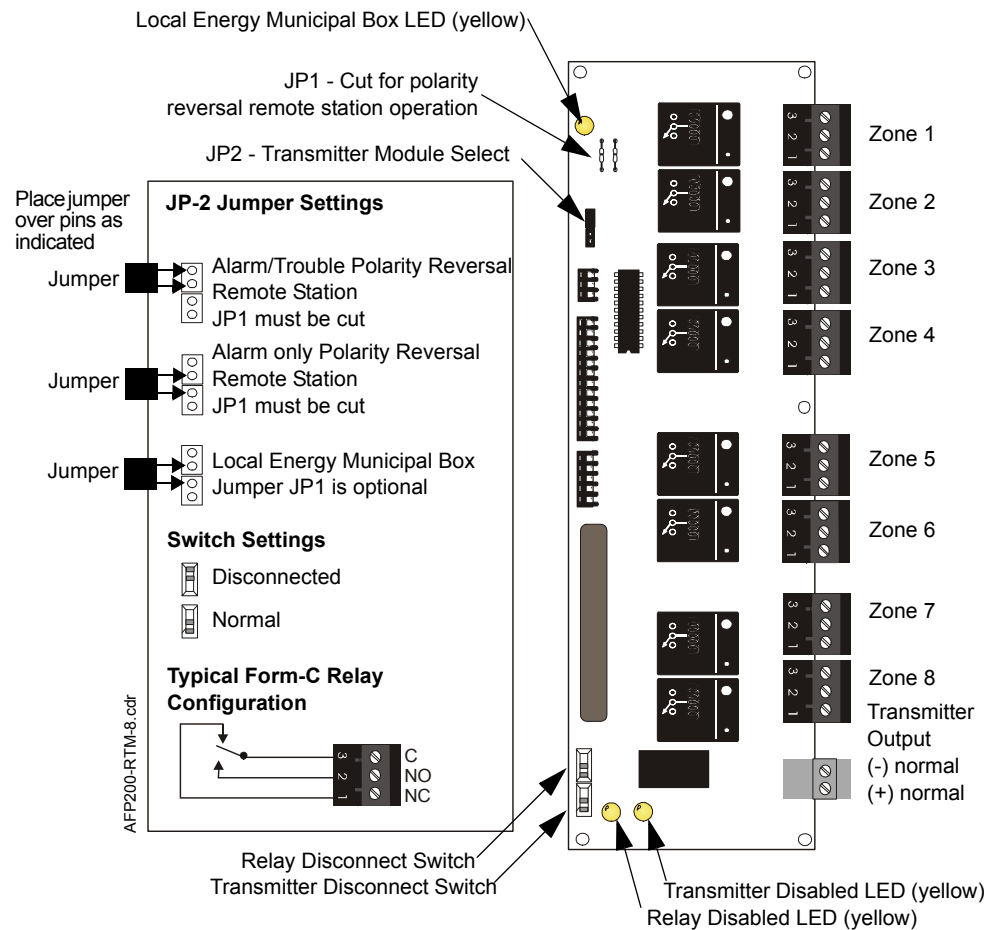

Figure 47 RTM-8 Module Connections

Notes on the RTM-8 module

1. Zone Relay Contact Ratings – 6 A @ 30 VDC or 300 VAC. Material: Silver Nickel.
2. Refer to the power-limited label located on the AFP-200 cabinet door. Make a notation on the label for each circuit used as a nonpower-limited circuit. (Refer to the example on the label).
3. Polarity Reversal Output – 24 VDC (nominal), 10 mA maximum rated current. Internal resistance: 1200 ohms (nominal). Intended for connection to the polarity reversal circuit of a remote station receiving circuit (Fire•Lite RS-82) having compatible ratings. Output is power-limited. Wiring can exit the protected premises.
4. Municipal Box output – Supervised for open circuit. Nonpower-limited. Maximum short current circuit: 0.6 A. Maximum open circuit voltage: 27.6 VDC. Maximum wire resistance: 3 ohms. Wiring can exit the protected premises.

The RTM-8 module is not suitable for separate transmission of both alarm and trouble signals to remote station.

Section 3 Programming

3.1 Overview

The AFP-200 is an intelligent, field-programmable Fire Alarm Control Panel. Field-programming the control panel lets you customize the fire alarm system by selecting and setting program options for addressable SLC devices (intelligent detectors, monitor modules, relay modules, and control modules), NACs, and Panel Circuits. There are two levels of programming—Program Change and Status Change. Each requires a password to restrict programming access to authorized personnel. For more details on Program Change and Status Change options, see Table 12.

3.1.1 Programming Methods

The control panel is completely field-programmable and requires no special software skills. You can program the control panel in one of two ways:

1. **Using the Autoprogram feature and the control panel keypad** is a convenient way to quickly bring the system on-line and to make changes to an existing system program. This chapter provides detailed instructions for programming the control panel using the keypad.
2. **Veri•Fire™** is an off-line programming utility that lets you create site-specific programming information using a Windows®-based computer. It is the preferred method for programs requiring a large amount of data entry. For detailed instructions, refer to Veri•Fire's on-line help program.

3.1.2 In This Section

For details on panel operation, refer to Section 4 "Operation".

This section provides information for programming the control panel, divided into the main sections that are listed in Table 12.

Section	Topic(s) covered	Refer to page
Getting Started	Programming Passwords	66
	How to Use the Programming Keypad	67
	Programming Shortcuts	68
	Upload and Download	68
Program Change Options	Instructions and sample screens for Program Change options used to configure and program operation of the control panel, such as: Autoprogramming, programming points, special zones, and system defaults; changing a program password; and checking the program for errors.	70
Status Change Options	Instructions and sample screens for Status Change options that do not affect configuration or basic operation of the control panel, such as: disabling/enabling points, setting system time/date, clearing counters, setting detector sensitivity, and walk-testing the system.	92

Table 12 Programming Topics

3.2 Getting Started

3.2.1 How to Access Programming Options

To enter Program Change mode or Status Change mode, follow these steps:



1. Press the ENTER key to enter programming mode and the LCD display shows the Programming Entry screen:

```

1=PROGRAMMING
2=READ STATUS ENTRY
<BACKSPACE TO ABORT>
  
```

Figure 48 Programming Entry Screen

2. Press the 1 key and the following screen appears in the LCD display:

```

ENTER PROG OR STATUS
PASSWORD, THEN ENTER.
<BACKSPACE TO ABORT>
  
```

Figure 49 Password Entry Screen

3. Enter the Program Change or Status Change password.

3.2.2 Programming Passwords

There are two programming passwords: Program Change and Status Change:

- Program Change password – The password used to access Program Change functions. The Program Change factory-set password is 00000.
- Status Change password – The password used to access Status Change functions. The Status Change factory-set password is 11111.

Passwords are user-definable (refer to “How to Change a Programming Password (3=passwd)” on page 85). If you enter an invalid password (or press the ENTER key without entering a password), the LCD display shows the Incorrect Password screen, like the one shown in Figure 50:

```

INCORRECT PASSWORD
PROGRAM: 0000000
STATUS: 0000000
BACKSPACE TO ABORT
  
```

Figure 50 Sample Incorrect Password Screen

From the Incorrect Password screen (Figure 50), press the BACKSPACE key and enter the correct Program Change or Status Change password or contact the manufacturer for assistance.

3.2.3 How to Use the Programming Keypad

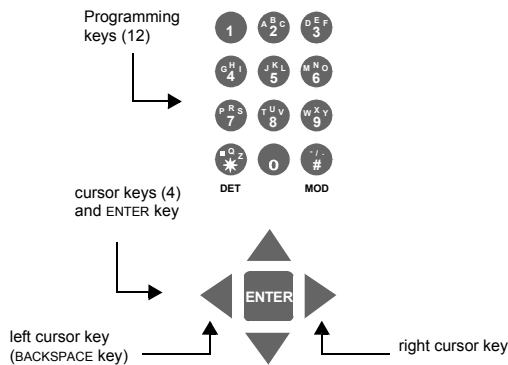

The programming keypad lets you enter numeric and alphabetic characters. Entering alphabetic characters is necessary for functions such as changing the LCD display message (“How to Change a System Message (4=message)” on page 86) and custom zone labels (“How to Change a Zone Label (5=zones)” on page 86). Table 13 shows examples of how to enter alphanumeric characters.

























To enter	Do this
10	1. Press  , then press  2. Press  , then press 
D16	1. Press  two times; then press  2. Press  , then press  3. Press  , then press 
Smoke 1	1. Press  four times, then press  2. Press  two times, then press  3. Press  four times, then press  4. Press  three times, then press  5. Press  three times, then press  6. Press  two times, then press  7. Press  , then press then press 

Table 13 Entering Alphanumeric Characters

During programming, the control panel automatically returns to normal operation after two minutes of inactivity.

3.2.4 Programming Shortcuts

“Programming Shortcuts” on page 68 lists shortcuts that you can use when programming the control panel.

To	Do this
To save a point's program into memory during Autoprogram or point programming	Press the ENTER key. After pressing the ENTER key, the autoprogram routine displays the next new detector or module.
To exit from Program Change or Status Change operations	Press the BACKSPACE key until the All Systems Normal screen appears, or press the SYSTEM RESET key.
To display the last 19-character label	When the blinking cursor is over the first letter of the label field, press the zero key twice to display the label entered for the previous point. If the last character of the label is a number, pressing the zero key a third time will increment this number. Once you recall the label, you can edit each character of the label.

Table 14 Programming Shortcuts

3.2.5 Upload and Download

An upload/download of the control panel may be done at any time by connecting a personal computer to the EIA-232 port and running the off-line programming routine. Refer to the Veri•Fire on-line help program for more information.

3.2.6 Key Programming Terms

Here is a list of terms that apply to control panel programming.

All Systems Normal message The message (up to 40 characters) in first two lines of the LCD display during normal system operation.

Autoprogram A control panel programming function that automatically detects new devices connected to the SLC, assigns default programming information, and also determines the total number of programmed devices.

CBE (Control-by-Event) A software function that provides a means to program a variety of output responses based on various initiating events.

Control module Addressable module that switches power to a Style Y or Style Z NAC.

CPU memory (Central Processing Unit) The nonvolatile element of the CPU that contains programming information for the control panel.

custom label A custom label is a user-defined message in an LCD display that identifies a device.

detector sensitivity A detector setting for an ionization or photoelectric detector that determines the level at which a detector will activate.

installed device An intelligent, addressable detector, control, monitor or relay module properly addressed and installed in a fire alarm system.

missing device A missing device is a detector or module removed from the SLC (TB6) that exists in the current program.

Monitor module An addressable monitor module that monitors conventional alarm-initiating devices.

NAC (Notification Appliance Circuit) A circuit or path directly connected to a notification appliance. (Notification appliances include bells, strobes, and horns that produce an audible signal, visual signal, or both.) You can use an NAC for coding functions (March Time, California Code, Temporal, and Two Stage).

new device New devices include detectors and modules connected to the SLC (TB6) that do not exist in the current program.

obscuration A smoke measurement, usually expressed in percent per foot (30.48 cm), that calculates reduction in the atmospheric transparency caused by smoke.

panel circuit One of four NACs (B01, B02, B03, or B04) available through TB2 on the control panel that connects to a notification appliance (such as a bell, strobe, horn, and so on). Each NAC can be programmed with CBE.

point A detector, module, or panel circuit properly installed, addressed, and programmed into the control panel.

Programming Keypad A set of keys on the membrane panel used for data entry and selection while programming the control panel.

Relay Module An addressable module that controls a Form-C relay.

SLC device An addressable detector, control, monitor or relay module connected to the control panel through TB6.

Type Code is a control panel software entity that defines the function of a detector, control, monitor or relay module, or panel circuit.

3.2.7 How to Avoid Programming Errors

You can avoid programming errors by making sure to follow these guidelines:

General Alarm (Z00)

If programming general alarm (Z00), note the following:

- Do not program a general alarm (Z00) to a releasing function.
- Do not program a general alarm (Z00) without an input point.

Releasing Zone (91–94)

If programming releasing zones (91–94), note the following:

- Do not program a releasing zone input (91–94) without at least one mapped RELEASE CKT output.
- Do not program a RELEASE CKT output without programming at least one releasing zone input (91–94).
- Do not program a releasing zone input (91–94) without programming at least one MAN. RELEASE zone.
- Do not program an Abort timer selected with Delay=00.

Cross Zones

If programming cross zones, a programming error will occur with any of the following conditions:

- A releasing zone, cross-zoned as type H, without at least one smoke detector and one heat detector mapped to the same releasing zone.
- A missing releasing input on cross-zoning function
- A missing different zone on releasing cross zone Z.
- A missing associated zone on releasing cross zoning.

Time Control (Z95, Z96)

- Do not program a time control function (Z95, Z96) as a releasing function.
- Do not program a heat detector to a time control zone (Z95, Z96).

3.3 Program Change Options

3.3.1 Overview

This section covers the following Program Change options:

Topic	Refer to
Clear programming memory	"How to Clear a Program from Memory (0=clr)" on page 73
Autoprogram the control panel	"How to Autoprogram the Control Panel (1=auto)" on page 73
Program a point for a: <ul style="list-style-type: none"> • detector • monitor module • control or relay module • panel circuit 	<ul style="list-style-type: none"> "How to Program an Intelligent Detector" on page 80 "How to Program a Monitor Module" on page 81 "How to a Program a Control or Relay Module" on page 83 "How to Program a Panel Circuit" on page 84
Change a programming password (Program Change or Status Change)	"How to Change a Programming Password (3=passwd)" on page 85
Create or change the system message on the display	"How to Change a System Message (4=message)" on page 86
Create or change a custom zone label	"How to Change a Zone Label (5=zones)" on page 86
Change the program for special Zones 90 through 99	"How to Edit a Special Zone (6=spl zones)" on page 87
Change system functions	"How to Edit System Functions (7=sys)" on page 89
Check the program for errors	"How to Check the Program (8=check)" on page 92

Table 15 Program Change Topics

3.4 How to Enter Program Change

To enter Program Change mode, follow these steps:



1. Press the ENTER key to enter programming mode and the LCD display shows the Programming Entry screen:

```

1=PROGRAMMING
2=READ STATUS ENTRY
<BACKSPACE TO ABORT>
  
```

Figure 51 Programming Entry Screen

2. Press the 1 key and the following screen appears in the LCD display:

```

ENTER PROG OR STATUS
PASSWORD, THEN ENTER.
<BACKSPACE TO ABORT>
  
```

Figure 52 Password Entry Screen

3. Enter your Program Change password. The control panel enters Program Change. The Program Change options appear in the LCD display as shown in Figure 53:

```

0=CLR 1=AUTO 2=POINT
3=PASSWD 4=MESSAGE
5=ZONES 6=SPL ZONES
7=SYS 8=CHECK PRG
  
```

Figure 53 Program Change Screen

In Program Change, the control panel trouble relay activates—but the panel sounder does not activate, and the System Trouble LED flashes.

The System Trouble LED remains flashing throughout all Program Change operations.

4. Select a Program Change option by pressing the numeric key (0-8) that matches the option. To exit Program Change and return to the Program Entry screen, press the BACKSPACE key.

3.4.1 Program Change Map

Figure 54 shows a map of the Program Change options. For each option (0-8) the map shows the main screen, a reference to the section, and a brief overview of the option.

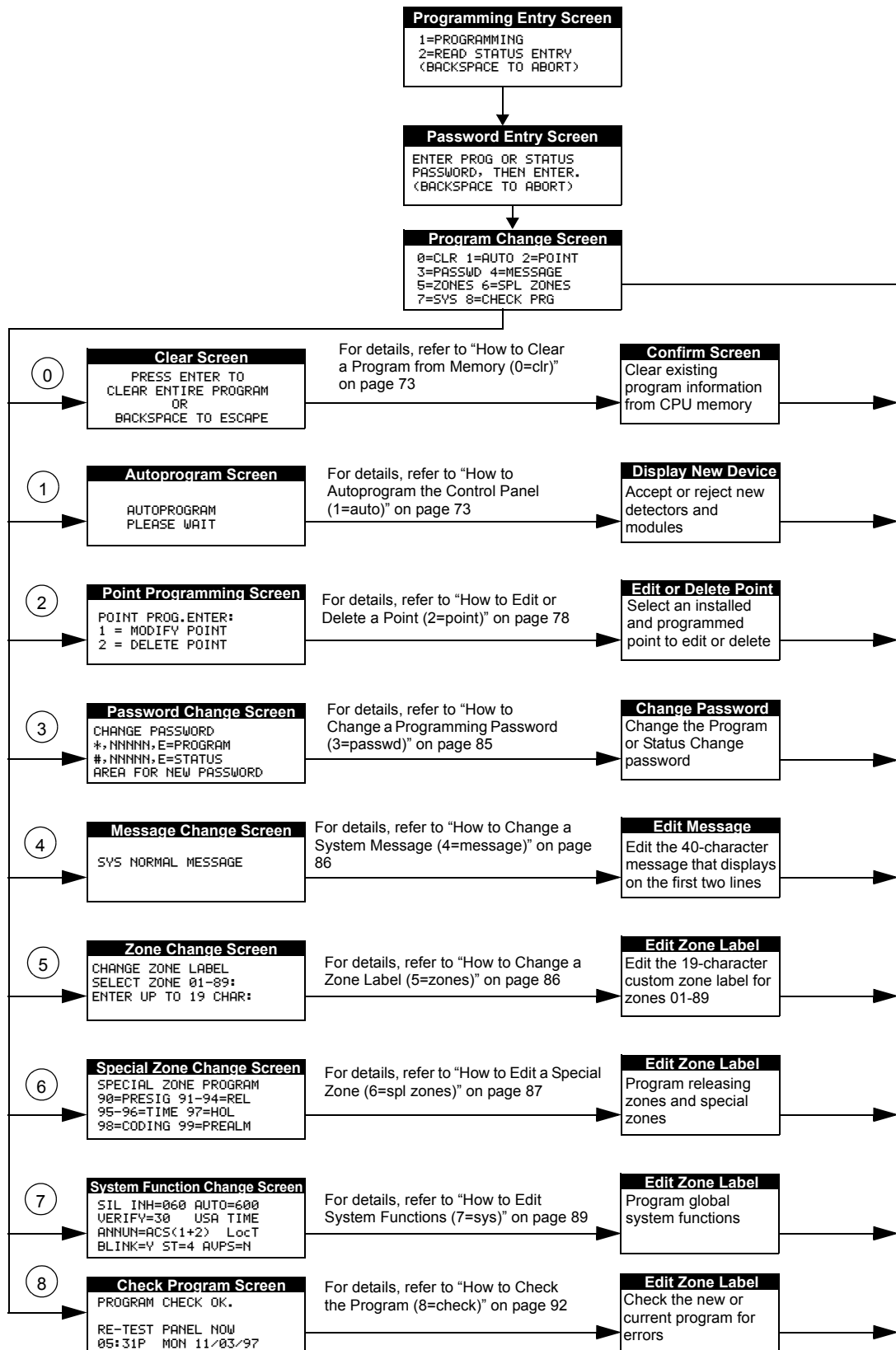

Figure 54 Map of Program Change Options



Program Change Password



3.4.2 How to Clear a Program from Memory (0=CLR)

The Clear option erases all programming information from the CPU memory of the control panel. You typically use the Clear function to erase data from the control before autoprogramming the control panel for the first time or if you remove one or more devices from the system. For more information on removing devices, refer to “How to Remove a Device from the Program” on page 76.

1. From the Program Change screen (Figure 53), press the 0 key. The Clear Program screen displays a verification prompt as shown in Figure 55:

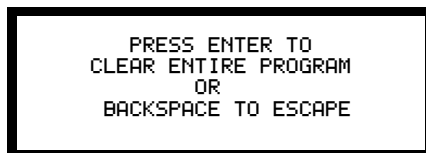

Figure 55 Clear Program Screen



CAUTION: Pressing the ENTER key causes the system to erase all existing programming data from CPU memory.

2. To erase existing programming data, press the ENTER key. To exit and return to the Program Change screen without erasing data, press the BACKSPACE key.

3.4.3 How to Autoprogram the Control Panel (1=AUTO)

Purpose

The Autoprogram option directs the control panel to identify all detectors and modules connected to the SLC. You can use the Autoprogram option to create a new program and add or delete addressable detectors and modules connected to the SLC. Table 16 contains a summary of the Autoprogram functions, when to use the functions, and where to find information on using the functions.



Program Change Password



Autoprogram Function	Control Panel Configuration	Refer to
Create a new program for the control panel	A new control panel or a control panel with no existing program in memory.	“Create a New Program for the Control Panel” on page 74
Add one or more SLC-connected detectors and modules to an existing program	A program exists in memory and you want to add a detector or module to the existing program—without modifying information for existing detectors and modules.	“How to Add a Device to the Program” on page 75
Remove one or more SLC-connected detectors and modules from an existing program	A program exists in memory and you want to remove an installed detector or module from the existing program—without modifying information for existing detectors and modules.	“How to Remove a Device from the Program” on page 76
View system defaults	A program exists in memory and you want to view system settings assigned during autoprogram, such as custom labels, passwords, and so on.	“How to Change Autoprogram System Defaults” on page 77

Table 16 Autoprogram Functions

Create a New Program for the Control Panel

This section covers how to use the Autoprogram option to create a new program for the control panel. The control panel will identify all addressable detectors and modules connected to the SLC then display default program information for each installed device.

Note: If your system includes a relay module, you must manually set this from “control” to “relay” after completing autoprogram. Refer to “How to a Program a Control or Relay Module” on page 83 for details.

To create a new program for the control panel, follow these steps:

1. Use the Clear option to clear program information from memory. For instructions on doing this, refer to “How to Clear a Program from Memory (0=clr)” on page 73.
2. From the Program Change screen, press the **1** key to start Autoprogram. The control panel scans the system to identify all detectors and modules connected to the SLC and displays the following screen:



Figure 56 Autoprogram Prompt

3. When finished identifying SLC devices, the LCD displays the first detector or module in the following order: detectors in address order (D01, D02, and so on), monitor modules in address order, and control or relay modules in address order. For example, Figure 57 shows a sample screen for a new device identified by the control program during autoprogram.

Default label for the device. To edit, refer to “How to Edit or Delete a Point (2=point)” on page 78.

Type Code for the device which you can only edit using the Point Programming option. For details, refer to “How to Edit or Delete a Point (2=point)” on page 78.

```

PROGRAM SMOKE<PHOTO>
DETECTOR ADDRESS 01
Z03 Z Z Z Z
2.0% *P* D01
    
```

Default Autoprogram information for the device. To edit this information, refer to “How to Edit or Delete a Point (2=point)” on page 78 for instructions.

Device address (detector at SLC address 01 shown)

Figure 57 Sample New Device Screen

- When a New Device screen displays, you can take one of the following actions:

You can	Do this
Accept default program information for the device	Press the ENTER key to save the default program information in memory for the device and display the next device.
Reject the device	Press the BACKSPACE key to reject the device (which prevents storing the device in memory) and display the next device.
Edit program information for the device	Use the programming keypad to edit program information for the device. For instructions on editing program information, refer to "How to Edit or Delete a Point (2=point)" on page 78). When finished editing device information, press the ENTER key to save the program information in memory for the device and display the next device.

Table 17 Autoprogram Options for New Devices

- Continue displaying and acting on each device. When the control panel completes displaying new devices, the Autoprogram Summary screen is displayed. The Autoprogram Summary screen—see Figure 58—displays the total number of detectors, modules, and panel circuits connected to the control panel.

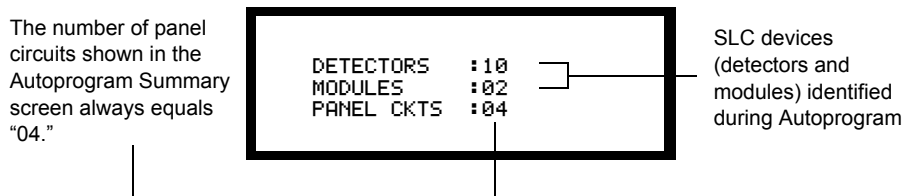

Figure 58 Sample Autoprogram Summary Screen

- Press the ENTER key, then press the BACKSPACE key to save the program in memory and return to the Program Change screen (Figure 53 on page 71); **or**
 Press the BACKSPACE key to exit without saving and return to the Program Change screen (Figure 53 on page 71).

How to Add a Device to the Program

You can also use the Autoprogram option to add addressable detectors and modules to the existing control panel program.

When using the Autoprogram option with an existing program, the control panel does not change program information for installed and programmed devices.

The following steps describe how to add a new detector at SLC address 04 with 10 detectors in the existing program:

- Install the addressable detector to the SLC at address 04 (for instructions, refer to Section 2 "Installation").
- From the Program Change screen (Figure 53), press the **1** key to start autoprogram. The Autoprogram Prompt screen (Figure 56 on page 74) appears in the LCD display as the control panel identifies addressable devices connected to the SLC.
- When finished identifying SLC devices, the control panel displays information for the new detector at SLC address 04 on the LCD display as shown in Figure 59.

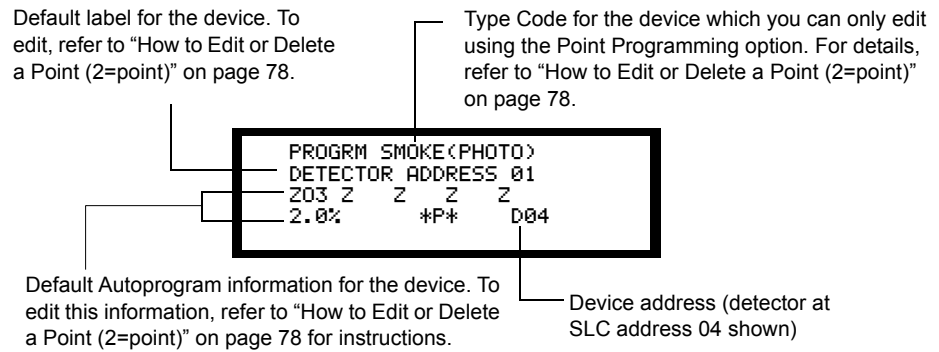

Figure 59 Sample New Device Screen

4. Press the ENTER key to add detector 04 to the program with the default program information. If you want to change the default information, use the programming keys to do so, then press the ENTER key to add detector 04 to the program. To reject the new device, press the BACKSPACE key to return to the Program Change screen.
5. The Autoprogram Summary screen appears. You can verify addition of the detector to the program by noting the new count of detectors as shown in Figure 60.

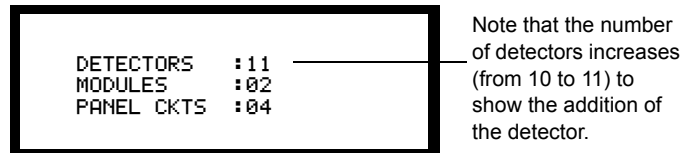

Figure 60 Sample Autoprogram Summary Screen

6. Press the ENTER key, then press the BACKSPACE key to save the program in memory and return to the Program Change screen (Figure 53 on page 71).

How to Remove a Device from the Program

You can also use the Autoprogram option to remove addressable detectors and modules from the control panel program.

The following steps describe how to delete a detector at SLC address 04 with 10 detectors in the existing program:

When using the Autoprogram option with an existing program, the control panel does not change program information for installed and programmed devices.

1. Disconnect and remove the detector from the SLC at address 04.
2. From the Program Change screen (Figure 53), press the 1 key to start Autoprogram. The Autoprogram Prompt screen (Figure 56 on page 74) while the control panel identifies addressable devices connected to the SLC.
3. When finished identifying SLC devices, the control panel displays a screen, indicating a missing detector at SLC address 04 as shown in Figure 61.

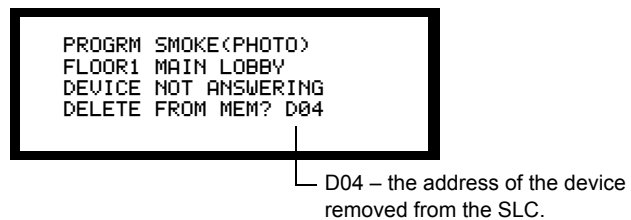
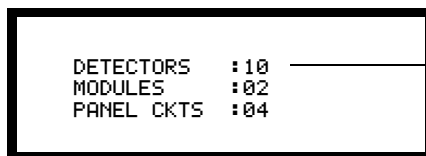

Figure 61 Sample Missing Device Screen

4. Press the ENTER key to delete detector 04 from the program and return to the Program Change screen (Figure 53 on page 71).

The Autoprogram Summary screen appears. You can verify removal of the detector from the program by noting the new count of detectors as shown in Figure 60.



Note that the number of detectors decreases (from 11 to 10) to show the removal of the detector.

Figure 62 Sample Autoprogram Summary Screen

5. Press the ENTER key, then press the BACKSPACE key to save the program in memory and return to the Program Change screen (Figure 53 on page 71).

How to Change Autoprogram System Defaults

The Autoprogram option automatically selects default system functions during initial programming of the control panel. You can change the default system functions. If you change any system default, then autoprogram the control panel, any new system values that you enter, do not change. For example, if you change a Program Change password, install new devices, and run the Autoprogram option, the new Program Change password remains unchanged. Table 18 contains default system functions and value.

System Function	Default Value	For more information, refer to
Zone 00	Custom label = GENERAL ALARM ZONE	"How to Edit or Delete a Point (2=point)" on page 78
Zones 01 through 89	Custom label is blank	"How to Change a Zone Label (5=zones)" on page 86
Zone 90	Label = PRESIGNAL/PAS DELAY, DELAY=180, PAS=N	"Programming a Presignal Zone (Z90)" on page 87
Zones 91-94	Label = RELEASE ZONE 91 DELAY=00, ABORT-ULI CROSS=N SOAK=00	"Releasing Control Zones (Zones 91-94)" on page 88
Zones 95 and 96	Label = TIME CONTROL ZONE 96, ON=00:00, OFF=00:00, DAYS=SMTWTFSH	"Time Control Change (Zones 95, 96)" on page 88
Zone 97	Label = HOLIDAY ZONE 97, all days are 00/00	"Holiday Change (Zone 97)" on page 88
Zone 98	Label = all blanks, CODE TYPE=MARCH TIME	"Code Type (Zone 98)" on page 89
Zone 99	Label = PRE-ALARM ZONE 99, ALERT=70% OF ALARM, ACTION=00% OF ALARM	"Pre-Alarm (Zone 99)" on page 89
System Parameters	SIL INH=000, AUTO=000, VERIFY=00, USA TIME, ANNUN=NON SUPV, LocT BLINK=Y, ST=4, AVPS=N	"How to Edit System Functions (7=sys)" on page 89
Programming Passwords	Program Change 00000 Status Change 11111	"Programming Passwords" on page 66 "How to Change a Programming Password (3=passwd)" on page 85
All Systems Normal Custom Message	Custom message label = 40 blanks	"How to Change a System Message (4=message)" on page 86

Table 18 Default Parameters for System Functions

3.4.4 How to Edit or Delete a Point (2=POINT)

Purpose

A *point* is a detector or module connected to the SLC or a device connected to one of the four panel circuits. The Point Programming (Point) option lets you do the following:

- Modify program information for a detector, module, or panel circuit point
- Delete a detector or module point from the program

This section contains instructions using the Point Programming option to do the following tasks:



Program Change Password



Task	Covers the following	Refer to page
How to Select a Point to modify or delete ^a	How to display a detector, module, or panel circuit point so you can modify or delete it	75
How to Program an Intelligent Detector ^a	How to modify program information for an addressable, intelligent detector	80
How to Program a Monitor Module ^a	How to modify program information for a monitor module	81
How to Program a Control or Relay Module ^a	How to modify program information for a control or relay module	83
How to Program a Panel Circuit	How to modify program information for any of the four NAC or Panel Circuits	84
How to Delete a Detector or Module Point ^b	How delete a detector or module point from the program	84

- To do this task, the device must be installed and programmed using the Autoprogram option.
- Deleting a point only deletes the point from program memory—not the device. For instructions on removing a device, refer to “How to Remove a Device from the Program” on page 76.

Table 19 Point Programming Topics

How to Select a Point

To select a point, follow these steps:

1. From the Program Change screen (Figure 53 on page 71), press the 2 key (Point) to display the Point Programming Entry screen (Figure 64).



Figure 63 Point Programming Screen

- From the Point Programming screen, press the **1** key to display the Modify Point Selection screen or press the **2** key to display the Delete Point Selection screen (Figure 64).

```
POINT PROG. ENTER:
DETECTOR=#, AA, E
MODULE=#, AA, E
BELLCKT=##, A, E
```

Modify Point screen

```
DELETE POINT. ENTER:
DETECTOR=#, AA, E
MODULE=#, AA, E
```

Delete Point screen

Figure 64 Modify and Delete Point Selection Screen

- From the Modify Point screen or the Delete Point screen, use the programming keys to display a device as shown in Table 20.

To Display a	Do this	Refer to
Detector	Press the * key, press the numeric keys that represent the detector SLC address (01-99), then press the ENTER key.	<ul style="list-style-type: none"> “How to Program an Intelligent Detector” on page 80 or “How to Delete a Detector or Module Point” on page 84
monitor, relay, or control module	Press the # key, press the numeric keys that represent the module SLC address (01-99), then press the ENTER key.	<ul style="list-style-type: none"> “How to Program a Control or Relay Module” on page 83 or “How to Program a Monitor Module” on page 81 “How to Delete a Detector or Module Point” on page 84
Panel circuit	Press the * key, press the # key, press the numeric key which represents the circuit address (01-04), then press the ENTER key.	“How to Program a Panel Circuit” on page 84
Notes: <ul style="list-style-type: none"> If you enter the address of a detector or module that is not installed, the control panel displays the point with the next highest address. Press the Up arrow key to display the point at the previous address or press the Down arrow key to select the point at the next address. You cannot delete a panel circuit. 		

Table 20 How to Display a Point

How to Program an Intelligent Detector

You can change program information for an addressable detector that is installed and programmed using the Autoprogram option. Figure 65 shows a sample display for a programmed detector. If editing the detector while using the Point: Modify option, you can modify all fields as shown in Figure 65.

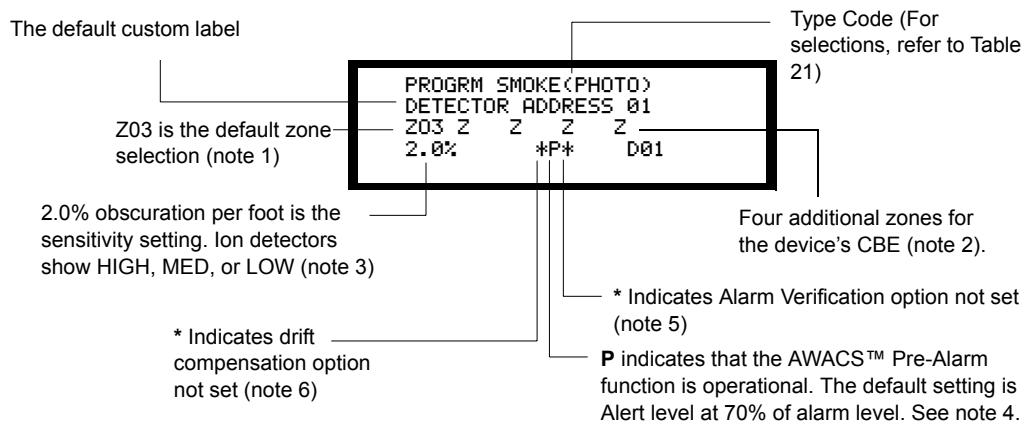

Figure 65 Typical Detector Point: Modify Screen

Notes for Figure 65:

1. **Default Zone Selection** Default zones are: Zone 01 (heat detectors), Zone 02 (ionization detectors), and Zone 03 (photo detectors).
2. **CBE selection** Four additional zones can be selected for the device’s CBE.
3. **Detector Sensitivity** If this is an FSI-751 ionization detector used in a duct application, the sensitivity must be set to HIGH. Refer to Section 4 “Operation” for details on selecting detector sensitivity.
4. **Pre-Alarm** To deselect Pre-Alarm, press the * key. For more information on selecting Pre-Alarm, refer to “Pre-Alarm (Zone 99)” on page 89 and Appendix G.
5. **Alarm Verification** Make sure to record detectors programmed for Alarm Verification on the Protected Premises Label located inside the cabinet door. To select Alarm Verification, replace the * with the a “V”. For more information on Alarm Verification, refer to Section 4 “Operation”.
6. **Drift Compensation** To select Drift Compensation, position the cursor over the first * and press the D (3) key. For more information on Drift Compensation, refer to Section 4 “Operation”

A Type Code defines the function of the detector. Table 21 contains a list of detector Type Codes:

Type Code	Detector Type
SMOKE (ION)	Ionization smoke detector (FSI-751)
SMOKE (PHOTO)	Intelligent smoke detector (FSP-751)
HEAT (ANALOG)	Intelligent thermal detector (FST-751)

Table 21 Detector Type Codes

How to Program a Monitor Module

Figure 66 shows a sample display of a typical monitor module Point: Modify screen. If editing the module while using the Point: Modify option, you can modify all fields as shown in Figure 65.

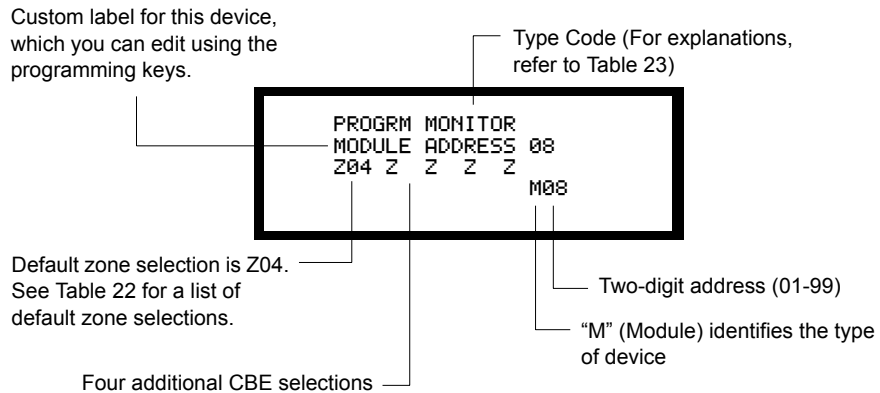

Figure 66 Sample Monitor Module Programming Display

Edit any field in the LCD display by following these steps:

1. Move the blinking cursor with the right cursor key to the field you want to edit.
2. Change the blinking fields by pressing the up cursor key, or by pressing a numeric key.

The primary programming task for editing monitor modules is selecting the Type Code. To do so, move the cursor to the Type Code field (the Type Code field blinks when selected). Select a Type Code by pressing the **up** cursor key until your Type Code selection appears (Table 23 contains a list of monitor module Type Codes).

Selection of a Type Code may change the functional operation of the monitor module point. For example, selecting the Type Code "Tamper" can define the monitor module to indicate an alarm for a security application

You can change the default zone (listed in **Table 22**) and add up to four zones for the CBE of each monitor module. **Table 22** contains the Autoprogram default zone selection for monitor modules.

Monitor module Address	Zone Default
01 through 19	Z04
20 through 39	Z05
40 through 59	Z06
60 through 79	Z07
80 through 99	Z08

Table 22 Monitor Module Default Zone Selection

Table 23 contains a list of monitor module Type Codes:

Type Code	Special function when activated	Nonlatching or Latching	Activate CBE?
MONITOR (default)	Monitor module used to monitor normally open contact, shorting-type devices.	latching	yes
PULL STATION	NBG-12LX addressable manual pull station	latching	yes
SMOKE DETECT	None	latching	yes
HEAT DETECT	None	latching	yes
Blank	None, select when no other Type Code applies.	latching	yes
WATERFLOW	Causes a non-silenceable alarm.	latching	yes
SUPERVISORY	Becomes a supervisory point (Refer to Section 4 "Operation").	latching	yes
TAMPER	Becomes a supervisory point (Refer to Section 4 "Operation").	latching	yes
NON FIRE	A special non-alarm point used for energy management or other non-fire situations (Refer to Section 4 "Operation")	nonlatching	yes
HAZARD ALERT	A special non-alarm point used for monitoring hazardous situations, such as a tornado (Refer to Section 4 "Operation").	latching	yes
FIRE CONTROL	A special non-alarm point used for air handler shutdown and are intended to override normal operating automatic functions (Refer to Section 4 "Operation").	nonlatching	yes
ABORT SWITCH	Aborts activation of a releasing zone (Refer to Appendix D "Releasing Applications.")	nonlatching	yes
MAN. RELEASE	Provide a manual release function and overrides the abort switch (Refer to Appendix D "Releasing Applications.")	latching	yes
SILENCE	Functions like the Alarm Silence switch.	latching	no
SYSTEM RESET	Functions like the System Reset switch.	nonlatching	no
EVACUATE	Functions like the Drill switch	latching	yes
PAS INHIBIT	Overrides a Presignal selection (Refer to Appendix H "Special Zones.")	nonlatching	no
TROUBLE MON	Short = Trouble (Refer to Section 3 "Programming" & Section 4 "Operation").	latching	yes
BURGLAR ALA	Causes Security Alarm on open or short (Refer to Appendix E "Combination Fire/Burglary Applications.")	latching	yes

Table 23 Monitor Module Type Codes

How to a Program a Control or Relay Module

A sample display of a typical control module Modify Point screen appears in Figure 67. If editing the module while using the Modify Point option, you can modify all fields as shown in Figure 67.

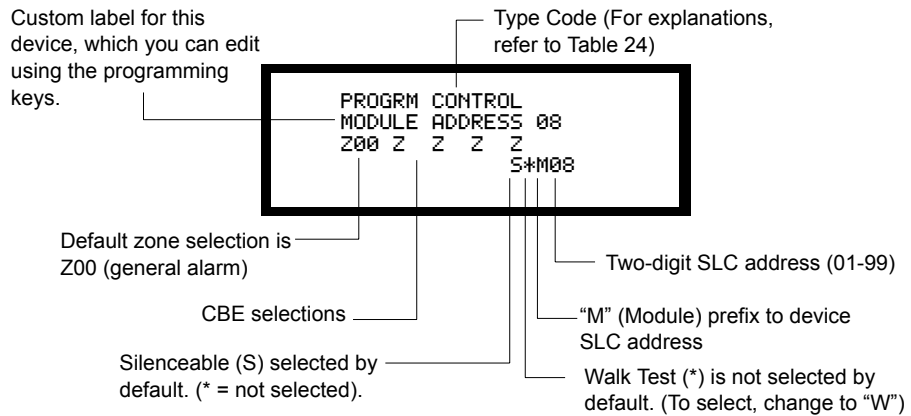

Figure 67 Sample Control or Relay Module Programming Screen

Press the ENTER key to accept default program information or press the BACKSPACE key to reject the default autoprogram information. Edit any field in the LCD display by following these steps:

1. Move the blinking cursor with the right cursor key to the field you want to edit.
2. Change blinking fields by pressing the up cursor key, or by pressing a numeric key.

Selection of control or relay module Type Code may change their function. Table 24 contains descriptions of the control or relay module Type Codes.

Type Code Label	Special Function
CONTROL	None (default)
RELAY	Ignore open circuit
STROBE CKT	None
BELL	None
HORN CIRCUIT	None
AUDIBLE CKT	None
BLANK	None, select when no other Type Code applies
RELEASE CKT	Short = Normal (nonpower-limited, see Appendix D)
REL CKT ULC	Short = Trouble (supervised and power-limited, see Appendix D)
RELEASE FORM_C	Contacts operated upon release
Note: A releasing circuit is always non-silenceable.	

Table 24 Control or Relay Module Type Codes

How to Program a Panel Circuit

Panel circuit program functions and Type Codes are similar to control modules, with the exception that they can not be used for agent release applications.

Because the four Panel Circuits are always installed, the autoprogram feature does not display Panel Circuits. Figure 68 shows a sample edit screen for Panel Circuit point programming:

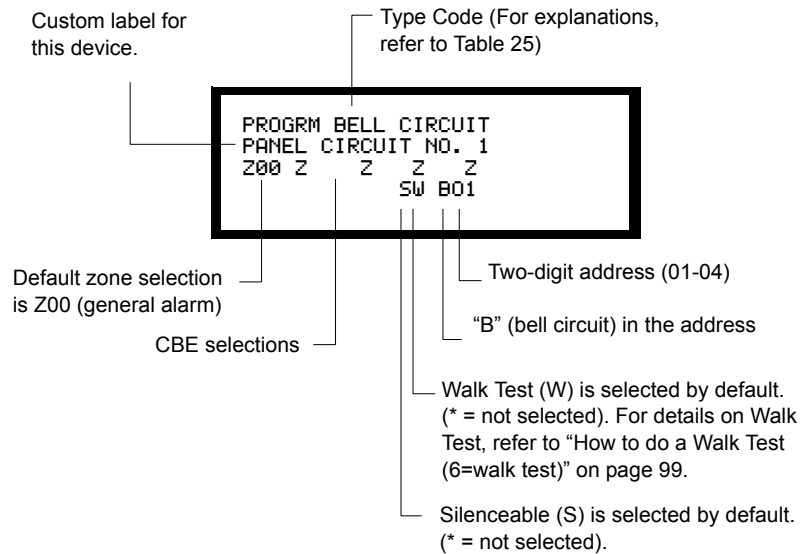

Figure 68 Sample Panel Circuit Edit Screen

To edit a Panel Circuit point select the Type Code. To do so, move the cursor to the Type Code field (the Type code field will blink when selected). Select a Type Code by pressing the up key until your desired Type Code appears. Table 25 contains a list of the Notification Appliance Circuits (NACs) Type Codes.

Table 25 contains Type Code selections for the four Notification Appliance Circuits:

Type Code Label	Special Function
BELL CIRCUIT	None (default)
STROBE CKT	None
HORN CIRCUIT	None
AUDIBLE CKT	None
blank	Use when no other Type Code applies

Table 25 Notification Appliance Circuit Type Codes

How to Delete a Detector or Module Point

You can use the Delete Point option to temporarily delete an intelligent detector or module point from program memory. Selecting option 2 from the Point Programming screen (Figure 63) lets you choose a detector or module point to delete. Figure 69 shows the Delete Point Selection screen and contains instructions for accessing a point.

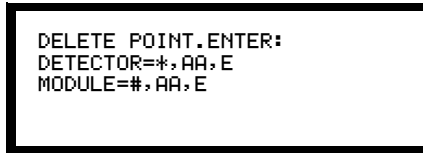

Figure 69 Delete Point Selection Screen

Instead of reentering the next point number or if you do not know the SLC address, you can press the up or down key to display the next lower or higher point.

From the Delete Point Selection screen, select a detector or module SLC address. If the selected point number is not installed, the control panel displays the next higher installed point.

Figure 70 shows a sample Delete Point screen for a smoke detector at SLC address 38:

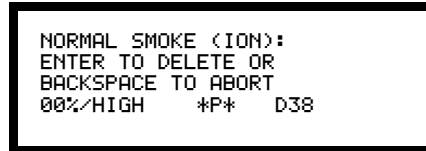

Figure 70 Sample Delete Point Screen

From the Delete Point screen, you can do the following:

- Press the ENTER key to delete the point and return to the Delete Point Selection screen; **or**
- Press the left cursor (backspace) key to keep the point in memory and return to the Delete Point Selection screen.

3.4.5 How to Change a Programming Password (3=PASSWD)

The Password Change function lets you enter the Program Change and Status Change passwords. A password must contain at least five numeric characters, no spaces allowed. To change a password, follow these steps:

1. From the Program Change screen (Figure 53 on page 71), select option 3 (Password). The LCD display shows the Password Change screen (Figure 71).



To change the Program Change password, press *, key in the new password, then press the ENTER key.



To change the Status Change password, press #, key in the new password, then press the ENTER key.

As the new Program Change or Status Change password is entered it displays on the fourth line.

Figure 71 Password Change Screen

2. Follow the instructions in Figure 71. To return to the Program Change screen without changing the password, press the left cursor (backspace) key. When finished changing the password, press the ENTER key to return to the Program Change screen.

3.4.6 How to Change a System Message (4=MESSAGE)

The Message Change screen lets you change the 40-character “All Systems Normal” message.



Program Change Password



1. From the Program Change screen (Figure 53 on page 71), select option 4 (Message) to display the Message Change screen (Figure 72).



Message entry area for entering up to 40 characters. Type a blank space in character position 20 or 21 so the words do not run together on an 80-character printer.

The first character on the third line blinks and may be changed to any alphabetic character by using the keypad, then pressing the right cursor to move to the next position.

Figure 72 Message Change Screen

For instructions on using the programming key, refer to “How to Use the Programming Keypad” on page 67.

2. Use the programming keypad to enter or edit the system message (up to 40 characters).
3. When finished entering characters, press the ENTER key to save the new message and return to the Program Change screen.

3.4.7 How to Change a Zone Label (5=ZONES)

The Zone Change function lets you add or modify a zone label. A zone label is a text entry that you can key in to describe a zone between 01–89. To change a zone label, follow these instructions:



Program Change Password



1. From the Program Change screen (Figure 53 on page 71), select option (5=Zones) to display the Change Zone Label screen. Figure 73 shows the Change Zone Label screen:

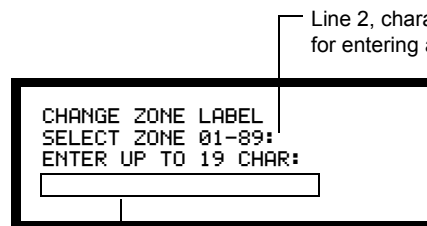

Line 2, character positions 19 and 20, for entering a zone number.

Line 4 – display area for existing zone label.

Figure 73 Zone Change Label Screen

For instructions on using the programming keys, refer to “How to Use the Programming Keypad” on page 67.

2. Select a zone to change by entering the zone number (01-89) in character positions 19 and 20 on the second line. For single-digit numbers, enter a leading zero before the digit (for example, enter “07” for zone 7).
3. The existing (if any) zone label displays on line 4 of the LCD display, characters 2 through 20. Character 1 on line 4 is blank to force a space between the device and zone labels when they are linked on the printer.
4. Add or change the zone label, then press the ENTER key. The zone label changes in memory and the LCD display returns to the Change Zone Label screen.
5. If the zone is out of range, the software ignores the ENTER key. To return to the Program Change screen, press the BACKSPACE key.

3.4.8 How to Edit a Special Zone (6=SPL ZONES)

Purpose of Special Zones (90-99)

Special zones include ten special software zones that you can program to do the following:



Special Zone	Description
90	A software zone used to select Presignal options.
91-94	Four software zones used to control releasing applications.
95, 96	Two software zones used to assign time control functions.
97	A software zone used to select holiday time controls.
98	A software zone used to select the type of coding for Panel Circuits.
99	A zone used to select the Pre-Alarm function.

Table 26 Special Software Zones 90-99

How to Select Special Zones

The Special Zone Change option you change the program for special Zones 90 through 99. From the Program Change screen (Figure 53 on page 71), select **6=SPL ZONES** to display the Special Zone Change screen. Figure 74 shows the Special Zone Change screen:

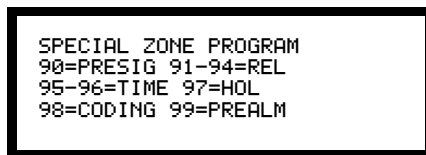

Figure 74 Special Zone Change Screen

From the Special Zone Change screen, you can select one of the options listed in Table 26. To select an option from the Special Zone Change screen, key in the number of the option. For example, to select the coding software zone, key in “98”; to select the releasing software zone 92, key in “92”. The following subsections show each screen that can be selected from the Special Zone Change screen (Figure 74).

Programming a Presignal Zone (Z90)

■ **What is a Presignal Zone?** You can use Presignal zone 90 when you want to delay control points for human verification. If zone 90 is included in a control or relay module or Notification Appliance Circuit CBE list, it inhibits all other CBE. Detectors and monitor modules must call out Zone 90 in their program to be included in the pre-signal/PAS operation.

When any alarm occurs and no PAS inhibit type monitor module is activated, Zone 90 activates. If a second alarm activates, or the Drill switch is pressed, Zone 90 goes false. If PAS is selected, and the Acknowledge switch is not pressed within 15 seconds, Zone 90 goes false. At the first alarm, a programmable 0–180 second timer starts. If an Alarm Silence occurs, the timer stops. If the delay timer expires, manual activation will activate outputs mapped to zone F0. The System Alarm relay, the 4XTM Polarity Reversal Alarm Output, and the 4XTM Municipal Box Output delay if PAS is selected, but do not delay for Presignal operations.

From the Special Zone Change screen (Figure 74), key in “90” to display the Presignal screen. Figure 75 shows a typical Presignal screen.

```

PRG SOFTWARE ZONE
PRESIGNAL DELAY
DELAY=180
PAS=YES          Z90
  
```

Figure 75 Presignal Screen

From the Presignal screen, you can change the delay time or the PAS selection. Refer to Appendix H for a detailed explanation of Presignal and PAS.

Releasing Control Zones (Zones 91-94)

From the Special Zone Change screen (Figure 74), you can key in 91, 92, 93, or 94 to display the Release Control screen (Figure 76). You can change delay times (0-60 seconds), abort type (ULI, IRI, NYC or AHJ), cross zoning (N, Y, H, or Z) or soak time (00, 10-15 minutes). Figure 76 shows a typical display:

```

PRG SOFTWARE ZONE
RELEASE CONTROL
DELAY=00 ABORT=ULI
CROSS=Y  SOAK=00 Z91
  
```

Figure 76 Release Control Screen

For descriptions and options for releasing zones, refer to Appendix D “Releasing Applications”.

Time Control Change (Zones 95, 96)

Time Control lets you change the start time, stop time, or days of the week. From the Special Zone Change screen (Figure 74), you can key in 95 or 96 to display the Time Control Change screen. Figure 77 shows a typical screen for changing the time using software zone 95:

```

PRG SOFTWARE ZONE
TIME CONTROL
ON=08:00 OFF=17:00
DAYS=SMTWTFSH    Z95
  
```

Figure 77 Time Control Change Screen

For descriptions and options for Time Control zones, refer to Appendix H “Special Zones”.

Holiday Change (Zone 97)

Software zone 97 (Holiday Change) lets you select up to nine holiday dates. Any device programmed to Software Zone 97 will be active on the holiday dates listed. From the Special Zone Change screen (Figure 74), key in 97 to display the Holiday Change screen. Figure 78 shows a typical Holiday Change screen:

```

PRG HOLIDAY ZONE 97
01/01 04/10 05/26
07/04 09/07 11/26
11/27 12/24 12/25
  
```

Figure 78 Holiday Change Screen

For descriptions and options for Holiday Zones, refer to Appendix H “Special Zones”.

Code Type (Zone 98)

Software zone 98 (code type), lets you select one of four code types: March Time, Temporal, California, or Two Stage. Selection of coding only has an effect if one or more Notification Appliance Circuits call out zone 98. From the Special Zone Change screen (Figure 74), you key in 98, to display the Code Type screen. Figure 79 shows a sample Code Type screen with a code type of March Time.

```

PRG SOFTWARE ZONE
CODE TYPE:
MARCH TIME
                Z98
  
```

Figure 79 Code Type Screen

For descriptions and options for Code Types, refer to Appendix H “Special Zones”.

Pre-Alarm (Zone 99)

Use software zone 99 to program the Alert or Action Pre-Alarm. From the Special Zone Change screen (Figure 74), enter 99 to display the Pre-Alarm screen. Figure 80 shows a sample Pre-Alarm screen.

```

PRG PRE-ALARM ZONE
ALERT=70% OF ALARM
ACTION=00% OF ALARM
                Z99
  
```

Figure 80 Pre-Alarm Screen

For descriptions and options for Pre-Alarm, refer to Appendix G “Pre-Alarm (AWACST™) Applications”.

3.4.9 How to Edit System Functions (7=sys)

Purpose

You can select global settings for nine system functions, which appear in the System Function Selection screen. Figure 81 shows a System Function Selection screen with default values in each system function field. The next section contains descriptions of each field and contains instructions for editing system functions.



Program Change
Password



```

SIL INH=000 AUTO=000
VERIFY=00 USA TIME
ANNUN=NON SUPV REMT
BLINK=Y ST=4 AUPS=N
  
```

Figure 81 System Function Default Values

Understanding System Functions

This section contains descriptions of the nine system functions, with the field name in parentheses, and the selections for each function.

- **SIL INH=** Lets you program a Silence Inhibit Timer that disables the Alarm Silence switch function when a fire alarm occurs. You can enter a timer value between 0-300 seconds or enter 000 for no timer. The timer starts at the first alarm and restarts with each new alarm.

An Alarm Verification Timer can reduce the amount of nuisance alarms caused by dirt and dust in a detector

■ **AUTO**= Lets you program an Auto Silence Timer that functions like pressing the Alarm Silence switch. For example, select 600. When the timer reaches 600 seconds (10 minutes), the control panel turns all active outputs that are programmed as silenceable.

■ **VERIFY**= Lets you program an Alarm Verification timer that tells the control panel to ignore a smoke detector alarm while the timer is counting. (The control panel ignores the Alarm Verification Timer if it detects another alarm during the alarm verification period.) If the time elapses and a smoke detector alarm still exists, the control panel performs all standard functions. If the timer expires and a smoke detector alarm no longer exists, the control panel increments the verification counter (up to 99) for the device and returns to normal operation.

■ **USA TIME** Lets you specify the format for system time and date that appears on the LCD display, terminal mode LCD-80s, and printouts. USA Time displays 12 hour clock with month/day/year. EUR displays a 24 hour clock with day/month/year and changes TROUBL to FAULT, and DISABL to ISOLAT in the Display Status field.

■ **ANNUN**= The Annunciation field lets you select the type of remote annunciation: No Supv, LCD-80, ACS Addr 1, ACS (1+2), or UDACT. Table 27 contains descriptions of each type:

Selection	Specifies
NO SUPV (default)	Terminal mode on; no annunciation used.
LCD 80 (T)	Select terminal mode interface (TB5 on the CPU; set SW2 to TERM) to annunciate all point information to a remote LCD-80.
ACS ADDR 1	Select ACS mode (TB5 on the CPU; set SW2 to ACS) to communicate with ACS mode devices, on Annunciator Address 1, which displays software zones 1-64
ACS (1+2)	EIA-485 port (TB5 on CPU-200) programmed for point annunciation (SW2 set to ACS) to communicate with ACS mode devices, on Annunciator Address 1, which displays the eight system points and software zones 1-64 and Annunciator Address 2, which displays software zones 57-99.
UDACT	Annunciate panel status to a UDACT which is connected and programmed to the control panel.

Table 27 Annunciation Selections

You cannot program an AVPS-24 or APS-6R for a combination Fire/Burglary application because the AVPS-24 Trouble input is also used to monitor the door tamper switch.

■ **AVPS**= You can program the control panel to supervise an installed AVPS-24 or APS-6R expansion power supply. For details on programming and installation of an AVPS-24/AVPS-24E or APS-6R, refer to Appendix J “Expansion Power Supplies”.

■ **Blink**= You can program the blink function of SLC-connected device LEDs during normal operation (selecting “Y” means devices blink and selecting “N” means devices do not blink). An SLC-addressable detector only blinks when the detector is tested (every three to four hours) but does not blink each time the control panel polls the detector.

■ **ST**= You can specify the wiring style used on the SLC: Style 4 (default) or Style 6 operation. Wiring and programming the SLC for Style 6 and a single fault occurs, the control panel detects a fault and drives both ends of the line, fully recovering from the fault. The control panel latches the trouble and displays the trouble until System Reset. Style 7 operation is the same as Style 6—but requires using ISO-X modules for isolating faults.

■ **LocT** You can specify the operating mode for a computer or terminal connected through the EIA-232 port (TB4) on the control panel. For detailed information configuring the control panel with a computer or terminal, refer to Appendix I “Terminal Interface Protocol”. Table 28 lists the operating mode selections.

Selection	Specifies
LocT (default)	A local CRT terminal or computer in the same room as the control panel that provides Read Status, Alter Status, Acknowledge, Silence, Drill, and System Reset functions.
LocM	Functions in the same manner as LocT except that it requires a password to execute the Acknowledge, Silence, Drill, and System Reset functions.
RemT	A remote terminal located away from the control panel that only allows the user to execute the Read Status function.

Table 28 EIA-232 Operating Mode Selections

How To Edit System Functions

This section contains instructions for editing system function fields. To do so, follow these steps:

1. From the Program Change screen (Figure 53 on page 71), select **7=SYSTEM** to display the System Function screen. Figure 82 shows a System Function screen with default system values.
2. Edit the system function values as shown in Figure 82. For additional information on each value, refer to “Understanding System Functions” on page 89.
3. When finished editing, press the **ENTER** key to return to the Program Change screen.

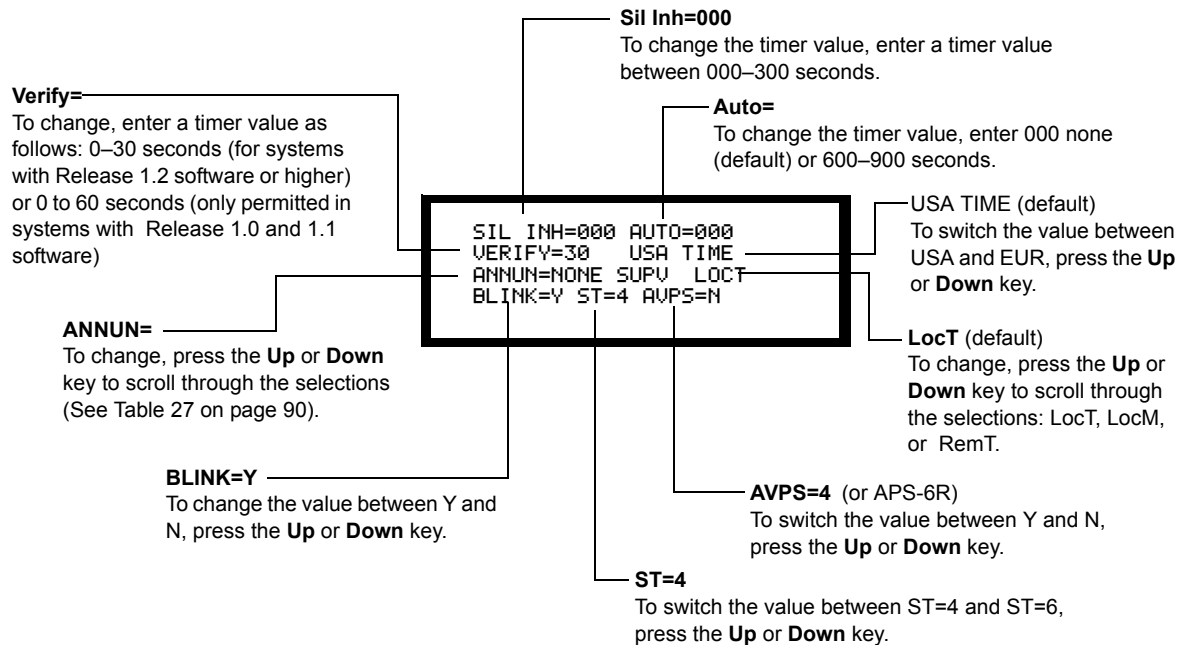

Figure 82 Editing System Functions



Program Change Password



3.4.10 How to Check the Program (8=CHECK)

When finished programming the control panel, use the Check option to search program entries for possible errors. From the Program Change screen (Figure 53 on page 71), select option 8, (Check). The control panel software searches the program for the following conditions:

- Output points mapped to a zone with no inputs mapped.
- A zone with programmed input point(s) without programmed output point(s), including Z00 (general alarm) outputs.
- Releasing zone inputs (91, 92, 93, and 94) with no RELEASE CKT outputs programmed to them; or RELEASE CKT outputs with no releasing zone (91-94) inputs programmed to them.
- RELEASE CKT inputs not mapped to MAN RELEASE.

If multiple devices fail the check, use the up or down keys to step through the devices. To correct any errors detected by the Check routine, return to point programming and correct the program errors.

Figure 83 shows a sample screen that appears when the system successfully completes a Program Check.



Figure 83 Program Check Screen

3.5 Status Change Options

Even though control program parameters may display in Status Change, the operator cannot access functions that affect basic operation of the control panel.

3.5.1 Overview

Status Change provides a second set of options accessed using the Status Change password (“Programming Passwords” on page 66). The Status Change options only allow change of operating parameters (listed in Table 29) that do not affect the basic configuration or control program. For instance, assign the Status Change password to persons who do not need to program applications or use the Autoprogram option.

This section covers the following Status Change topics:

Topic	Refer to
Disable or enable a detector, module, or Panel Circuit point.	“How to Disable or Enable a Point (1=disable)” on page 95
Change detector sensitivity for an intelligent photo or ion detector	“How to Set Detector Selections (2=sens/comp)” on page 96
Clear verification counters used with the Alarm Verification feature	“How to Clear Alarm Verification Counters (3=clr ver)” on page 97
Clear history from memory	“How to Clear the History Buffer (4=clr hist)” on page 98
Set system time and date	“How to Set the System Time and Date (5=time)” on page 98
Walk test the system	“How to do a Walk Test (6=walk test)” on page 99

Table 29 Status Change Topics

3.5.2 Entering Status Change

For more information on programming passwords, refer to "Programming Passwords" on page 66.

You access all Status Change options from the Status Change screen (Figure 84). From the Program Entry screen (Figure 48 on page 66), enter your Status Change password to display the Status Change screen (Figure 84).

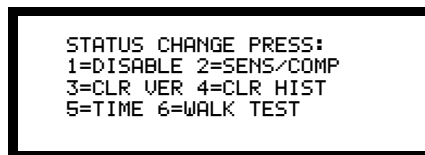

```
STATUS CHANGE PRESS:  
1=DISABLE 2=SENS/COMP  
3=CLR VER 4=CLR HIST  
5=TIME 6=WALK TEST
```

Figure 84 Status Change Screen

Status Change operations (except for Walk Test) have a two-minute timer. (The Walk Test feature has a 1-hour timer.) If no keys are pressed for two minutes, the control panel exits Status Change and returns to normal operation.

3.5.3 Status Change Programming Map

Figure 85 shows a map of the Status Change programming options. For each programming option (1-6) the map shows the main screen, a reference to the section with the instructions, and a brief overview of the option

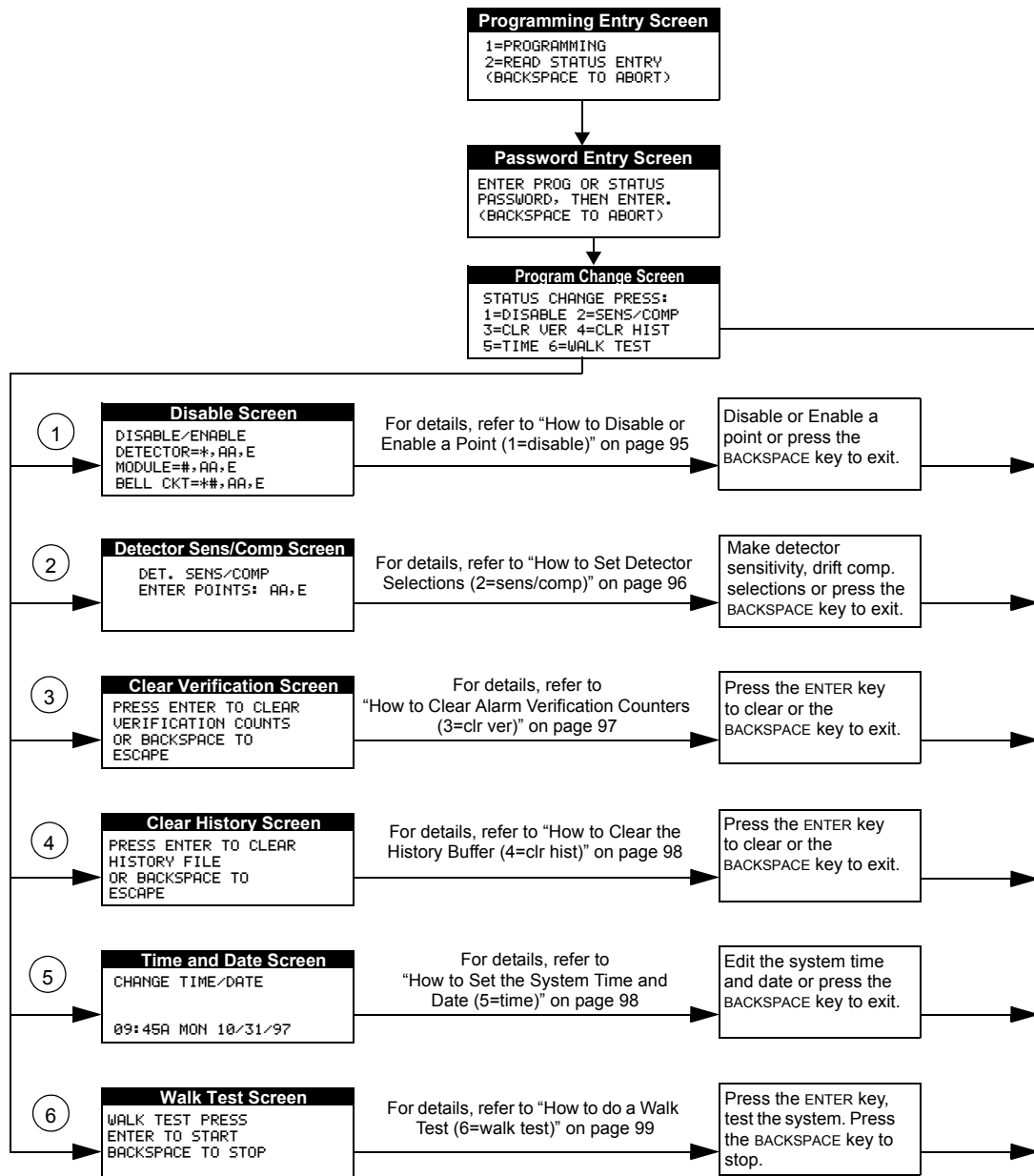

Figure 85 Map of Status Change Programming Options

3.5.4 How to Disable or Enable a Point (1=DISABLE)



WARNING:
Disable is a software function.
Do not use as a lockout in releasing applications.



Status Change
 Password



The Disable/Enable option lets you disable or enable a programmed SLC point or panel circuit—except for an initiating device in alarm or a output/control point that is on. To disable or enable a programmed point or panel circuit, follow these instructions:

1. From the Status Change screen (Figure 84 on page 93), press the **1** key to display the Disable/Enable screen as shown in Figure 86.

To select a **module**: a) press the # key, press the numeric keys that represent the module SLC address (01-99), then press the ENTER key.

To select a **detector**: a) press the * key, press the numeric keys that represent the detector SLC address (01-99), then press the ENTER key.

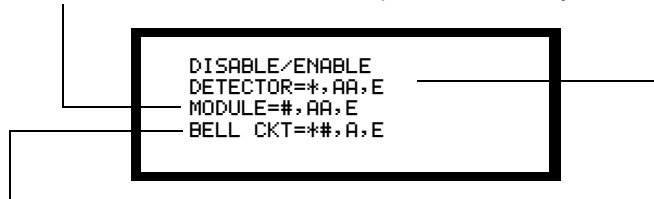

To select a **panel circuit**: a) press the * key, press the # key, then enter the address of the panel circuit (1, 2, 3, or 4), then press the ENTER key.

Figure 86 Disable/Enable Screen

2. Enter the type of point to be disabled or enabled (* for detectors, # for modules, or * and # for panel circuits), enter the two-digit SLC address of the point or the panel circuit number; then press the ENTER key. The control panel displays an edit screen for the point. For example, Figure 87 shows an edit screen for the NAC at address B01.

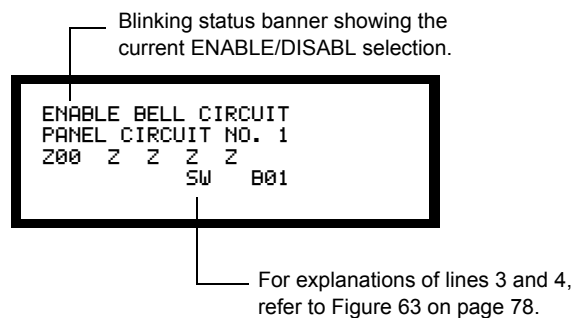

Figure 87 Sample Edit Screen for Disabling or Enabling a Point

3. Toggle the status banner to DISABL or ENABLE by pressing the **up** or **down** key.
4. When finished selecting the Enable/Disable status banner, press the ENTER key. The control panel updates memory to the selected status and returns to the Disable/Enable screen (Figure 86).
5. To continue with the Enable/Disable option, you can select another point. Do so by entering a new point number or pressing the **up** key to go to the next address point, or press the **down** key to go to the previous address point.
6. When finished selecting Enable/Disable selections, press the BACKSPACE key to return to the Status Change screen (Figure 84 on page 93).

3.5.5 How to Set Detector Selections (2=SENS/COMP)

Purpose

The Sens/Comp option lets you select detector sensitivity and drift compensation for photoelectric and ionization detectors.

You can select drift compensation for any intelligent detector on the SLC. Drift compensation provides accurate and stable readings of smoke, counteracting long-term drift caused by dust contamination and other long-term environmental factors. Drift compensation quickly detects true fires, rejects false signals—while allowing a detector to remain within performance specifications throughout its life span. Table 30 lists the three drift compensation measurements performed for each ionization or photoelectric detector.

Feature	Description
long-term measurement of location's clear air	An average reading which adjusts to gradual buildup of dust contamination, unaffected by true smoke, even from smoldering fires.
alarm test level measurement	A periodic detector test that commands each detector to simulate an alarm level reading from the sensing chamber.
current chamber reading	Under normal conditions, this reading is close to the stored air clear value. If smoke occurs, the reading moves toward the alarm test level.

Table 30 Drift Compensation Measurement

The control panel converts the present reading to percent per foot obscuration or percent of alarm, based on its position between the known clean air and test values. The accuracy of this measurement method is sufficient to meet the NFPA 72 requirements as a calibrated smoke test instrument.

What are Detector Sensitivity Selections?

You can set the sensitivity level for an ionization or a photoelectric detector. Table 31 contains a list of UL-approved detector sensitivity settings for intelligent detectors.

Type of Detector	Sensitivity Selection
Ionization (FSI series)	H (high) M (medium), or L (low) Note: If using older (DH500 series) ionization detectors for duct applications, set the detector sensitivity to "H".
Photoelectric (FSP series)	2.0 , 1.5 , of 1.0 percent obscuration per foot

Table 31 Ionization and Photoelectric Detector Sensitivity Selections

How to Select Detector Sensitivity and Drift Compensation

To change detector sensitivity, drift compensation both, follow these steps:

1. From the Status Change screen (Figure 84 on page 93), press the **2** key to display the Detector Sensitivity/Comp screen (Figure 88).



Status Change
Password

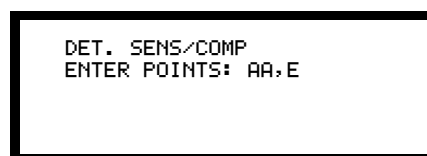

Figure 88 Detector Sensitivity/Comp Screen

If you enter an address for an analog heat detector (FST) or other invalid address, the LCD display returns to Detector Sensitivity/Comp screen.

2. Enter a valid detector SLC address and the control panel displays information for the detector on a screen similar to sample screen shown in Figure 89 with the current detector sensitivity selection blinking.

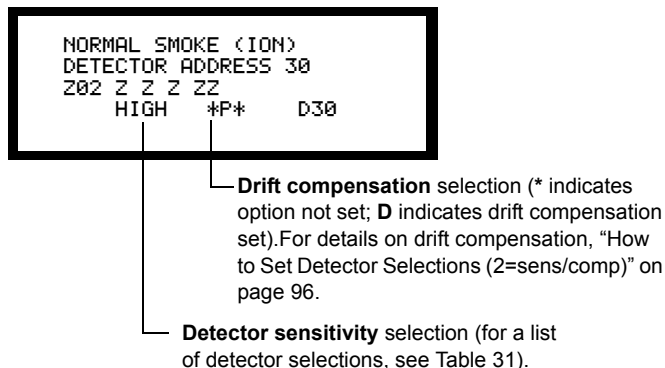

Figure 89 Sample Screen for Changing Detector Selections

To exit the screen and return to the Detector Sensitivity/Comp screen, press the BACKSPACE key from the Detector Sensitivity selection.

3. To change the **detector sensitivity**, move the cursor to the current detector selection. Press the **Up** or **Down** key to change the detector sensitivity. For selections, see Table 31 on page 96.
4. To enable or disable **drift compensation**, move the cursor to the drift compensation selection. Press the **Up** or **Down** key to toggle the detector sensitivity between **D** (enabled) or ***** (disabled).
5. When finished making selections, press the ENTER key to return to the Detector Sensitivity/Comp screen.
6. To change selections for another detector, press the **up** key to display the installed detector at the next highest SLC address or press the **down** key to display the installed detector at the next lowest SLC address.

3.5.6 How to Clear Alarm Verification Counters (3=CLR VER)

Purpose

The control panel provides a verification counter for each photoelectric and ionization detector programmed for Alarm Verification. (Alarm Verification time is a global program selection, covered in “How to Edit System Functions (7=sys)” on page 89.) The verification counter displays the number of times that a detector entered Alarm Verification but did not time out to alarm. The verification counter increments to 99 and holds. For instructions on viewing the verification counter, refer to 4.9 “Read Status”.

Clearing the Alarm Verification Counters

The Clear Verification Count screen (Figure 90) lets you clear all verification counters for detectors selected for Alarm Verification. To clear all verification counters, follow these steps:

1. From the Status Change screen (Figure 84 on page 93), press the **3** key to display the Verification Count Clear screen as shown in Figure 90:



Status Change Password

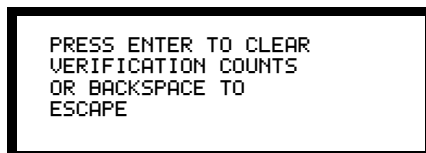

Figure 90 Verification Count Clear Screen

2. Press the ENTER key to clear the verification counters or press the BACKSPACE key to return to the Status Change screen (Figure 84) without clearing the verification

counters.

3.5.7 How to Clear the History Buffer (4=CLR HIST)

Purpose

The History buffer is an electronic record of the last 650 events recorded by the control panel. Events in the History buffer include all alarms, troubles, and operator actions, such as Acknowledge, System Reset, Signal Silence, Manual Evacuate (Drill), and Walk Test. The control panel also records each programming entry, which includes a number indicating the programming submenu (0-9). All events are time and date stamped. For information on reading or printing the History buffer, refer to 4.9.5 “Using the History Buffer”.

Clearing the History Buffer

The Clear History option lets you clear the entire contents of the History buffer from the control panel memory. For more details on the History buffer, refer to Section 4 “Operation”.

1. From the Status Change screen (Figure 84 on page 93), press the **4** key to display the Clear History as shown in Figure 91.

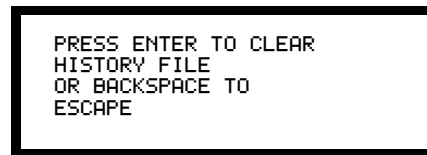

Figure 91 Clear History Screen

2. Press the ENTER key to clear the contents of the History buffer or press the BACKSPACE key to return to the Status Change screen (Figure 84) without clearing.

3.5.8 How to Set the System Time and Date (5=TIME)

Purpose

The Change Time and Date option lets you set the system time and date, which also appears on the LCD display. For instructions on selecting the time and date format (USA or European), refer to “How to Edit System Functions (7=sys)” on page 89.

Setting the System Time and Date

To set the system time and date, follow these instructions:

1. From the Status Change screen (Figure 84 on page 93), press the **5** key to display the Time and Date screen. Figure 92 shows a sample Time and Date screen:

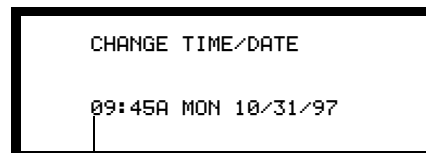

The first digit of the hours flashes. Change digits by keying in digits with the programming keys. Pressing the right cursor moves to the next digit, and so on.

Figure 92 Time and Date Screen (USA time format shown)

2. Use the programming keypad to change the time and date, using the cursor keys to move the cursor as needed.
3. When finished entering the time and date, press the ENTER key to change the time and date in system memory and return to the Status Change screen.

3.5.9 How to do a Walk Test (6=WALK TEST)



WARNING: A Walk Test can deactivate fire protection. When conducting a Walk Test, make sure to do the following:

- **Secure all protected buildings, and notify the building owner/operator, fire department, and other persons that testing of the system is in progress.**
- **When finished doing a Walk Test, exit Walk Test immediately and return the system to normal operation.**
- **Notify the building owner/operator, fire department, and other persons that testing is complete and the system is operating normally.**

Purpose

The Walk Test option lets one person test the entire system without returning to the control panel. Typically, you do a Walk Test by activating a set of devices in a planned sequence. When you finish a Walk Test, you can compare the History buffer against the planned test sequence.

There are two types of Walk Test, Standard and Silent, which are determined by the way the outputs are programmed:

- A Standard Walk Test is a test that sounds each output programmed for Walk Test for 3 seconds. Program outputs for Walk Test.
- A Silent Walk Test is a test that sends test information to a printer but does not sound outputs. Do not program any outputs for Walk Test.

Figure 93 shows a sample programming screen with a control module selected for a Standard Walk Test. For more information on selecting outputs for Walk Test, refer to “How to a Program a Control or Relay Module” on page 83 or “How to Program a Panel Circuit” on page 84.

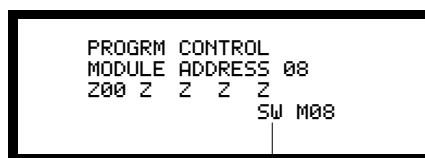

Walk Test selected for the module.
(To select for Silent Walk Test,
change the “W” to an asterisk (*))

Figure 93 Sample Control Module Programmed for Silent Walk Test

The Control Panel in Walk Test

When in Walk Test, the control panel does the following:

- Accepts each new alarm and activates its programmed outputs for approximately 3 seconds. For details on programming points for Walk Test activation, refer to “How to Edit or Delete a Point (2=point)” on page 78).
- Saves and stores each test in the History buffer.
- Sends a TEST Axx (xx is the number of tests for a detector with this SLC address) status banner for each alarm to the printer.
The “TEST Axx” message may be used to find installation errors. After walk-testing the entire system and setting each device into alarm once, if two devices are set to the same SLC address, a “TEST 02” will be reported for that SLC address. The installer should verify that no “TEST 02” or higher entries exist in the History buffer.
- Turns on the System Trouble LED and the System Trouble relay. If a new trouble occurs, all control modules programmed for Walk Test activate for 8 seconds and

the control panel sends a trouble banner (“TEST Txx”) to the History buffer and optional printer.

- Turns off the System Alarm relay.

Doing a Walk Test

This section contains instructions for performing a Standard and Silent Walk Test. Follow these procedures for doing both types of Walk Test. The difference between a Standard and Silent Walk Test is the programming of the outputs as shown in “How to Edit or Delete a Point (2=point)” on page 78.

To do a Standard Walk Test, follow these steps:

1. From the Status Change screen (Figure 84 on page 93), press the **6** key to display the Walk Test Entry screen as shown in Figure 94:

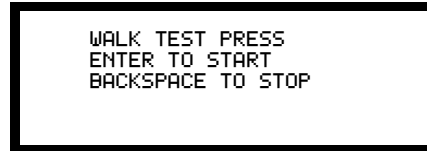

Figure 94 Walk Test Entry Screen



To stop Walk Test at any time, press the BACKSPACE key and the control panel returns to the Status Change screen. A 1-hour timer automatically returns the control panel to normal operation after 1 hour of inactivity.

2. From the Walk Test Entry screen, press the ENTER key. The control panel goes into Walk Test and the Walk Test screen appears as shown in Figure 95:



Figure 95 The LCD Display in Walk Test

3. Test your output devices.
4. When finished with the Walk Test, press the BACKSPACE key to return the control panel to normal operation as shown in the sample screen in Figure 96.

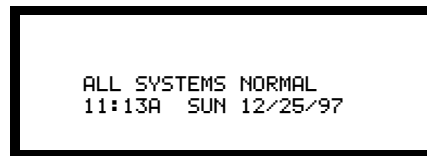

Figure 96 Sample LCD Display in Normal Operation

5. View the History buffer and printer output (if installed) to check the results of the Walk Test.

WARNING: When finished doing a Walk Test:



- Exit Walk Test immediately and return the system to normal operation.
 - Notify the building owner/operator, fire department, and other persons that testing is complete and the system is operating normally.
-

Section 4 Operation

4.1 Overview

This section provides information for operating the control panel, divided into the main sections that are listed in Table 32.

Section	Topic(s) covered	Refer to page
The Membrane Panel	How to Use the Programming Keypad	102
	How to Use the Enter Key and Cursor Keys	103
	How to Use the Operator Keys	103
	How to Read System Status LED Indicators	105
How to Operate the Control Panel	How to Operate the Panel in Normal Operation	107
	How to Operate a Panel with a Trouble Condition	107
	How to Operate a Panel with a Trouble Monitor Point	109
	How to Operate a Panel with a Fire Alarm	109
	How to Operate a Panel with a Supervisory Condition	110
	How to Operate a Panel with a Non-Alarm Condition	111
How to Operate the Panel with an Output Circuit Trouble	111	
Control-By-Event Operation	Control-By-Event Operation	112
Releasing Functions	Releasing Functions	113
Time Functions	Time Functions	116
Read Status	Read Status	118

Table 32 Operation Topics

4.2 The Membrane Panel

4.2.1 Overview

Figure 97 shows the Membrane Panel, which contains the Programming Keypad, the Enter and Cursor keys, the Operator Keys, and the System Status LED Indicators.

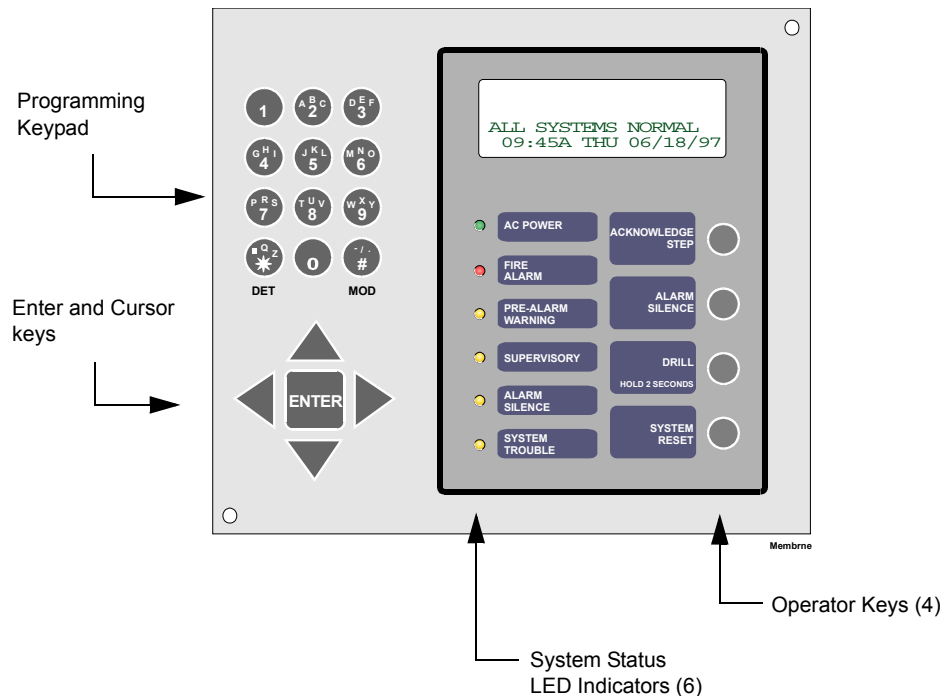

Figure 97 The Membrane Panel

4.2.2 How to Use the Programming Keypad

The programming keypad lets you enter numeric and alphabetic characters. Entering alphabetic characters is necessary for functions such as entering custom labels and system messages. Figure 98 contains an illustration of the Programming Keypad.

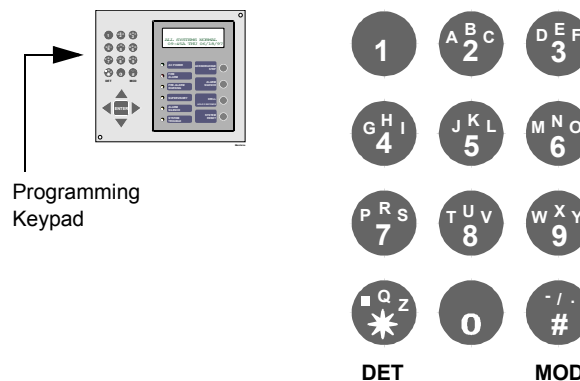

Figure 98 Programming Keypad

To learn how to enter alphanumeric characters on the Programming Keypad, “How to Use the Programming Keypad” on page 67.

4.2.3 How to Use the Enter Key and Cursor Keys

The Enter key and Cursor keys provide key functions such as: the cursor movement, scrolling, and backspace. Figure 99 contains an illustration of the Programming Keypad.

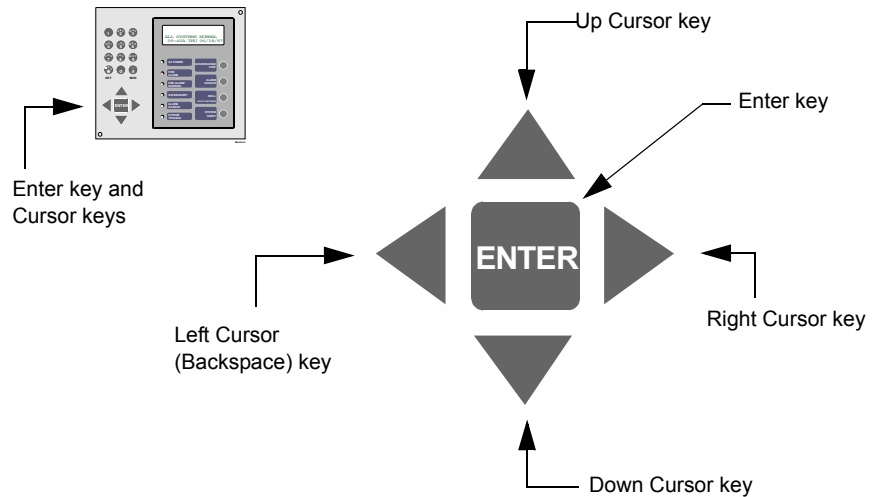

Figure 99 Enter Key and Cursor Keys

The Enter keys and Cursor keys can perform different functions, depending on the type of operation involved. Table 33 lists functions of the Enter key and the Cursor keys, with the alternate function of the cursor key in parentheses.

Key	Functions
Enter	<ul style="list-style-type: none"> When the control panel is in normal operation, press the Enter key to display the Programming Entry screen (Figure 112 on page 119). Use to complete a programming function, such as entering data, to save data to memory and return to a previous screen.
Left Cursor (backspace)	The left cursor key can do the following: <ul style="list-style-type: none"> Move the cursor – Press to move the blinking cursor one place to the left. Backspace – Press to return to a previous screen.
Up Cursor (scroll up)	<ul style="list-style-type: none"> Press to move the blinking cursor up one line; or Press to step back through a list of choices, such as selecting a type code during point programming.
Right Cursor	Press to move the blinking cursor one place to the right.
Down Cursor (scroll down)	<ul style="list-style-type: none"> Press to move the blinking cursor down one line; or Scroll – Press to step forward through a list of choices, such as selecting a type code during point programming.

Table 33 Functions of the Enter Key and Cursor Keys

4.2.4 How to Use the Operator Keys

The Membrane Panel (see Figure 97 on page 102) contains four Operator Keys: ACKNOWLEDGE/STEP, ALARM SILENCE, DRILL, and SYSTEM RESET. This section provides the purpose and operation of each operator key.

Acknowledge/Step



■ **Purpose.** Pressing the ACKNOWLEDGE/STEP key silences the panel sounder and changes all flashing alarm, trouble, and supervisory LEDs to steady.

■ **Operation** Press the ACKNOWLEDGE/STEP key once, no matter how many new alarm, trouble, or supervisory signals exist. If the panel sounder is silenced, the control panel sends an acknowledge message to the History buffer and any printers installed. Pressing the ACKNOWLEDGE/STEP key also automatically sends a command to silence the sounders on installed Terminal Mode LCD-80s and installed ACS annunciators.

If multiple alarms, troubles, and supervisory signals exist, pressing the ACKNOWLEDGE/STEP key will silence all signals. This is called a "block acknowledge"

Use the STEP function if more than one event exists as follows:

1. Press the ACKNOWLEDGE/STEP key to step the LCD display to the next event. The control panel displays the event for 20 seconds or until the ACKNOWLEDGE/STEP key is pressed again.
2. Continue pressing the ACKNOWLEDGE/STEP key to step through each event.

Alarm Silence



■ **Purpose** Press the ALARM SILENCE key to turn off all silenceable circuits and audio visual devices connected to NAC/Panel Circuits when an alarm sounds.

■ **Operation** Pressing the ALARM SILENCE key does the following:

- Silences the panel sounder
- Lights the ALARM SILENCE LED
- Turns off all silenceable audio and visual devices (such as bells and horns) connected to NAC/Panel Circuits
- Sends an Alarm Silenced message to the History buffer, installed Terminal Mode LCD-80s, and installed printers

A subsequent new alarm will resound the system.

Drill

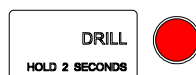

■ **Purpose** Press the DRILL key to manually test notification appliances.

■ **Operation** Press the DRILL key for at least two seconds (to prevent accidental activations), to activate notification appliances. The control panel does the following:

- Turns on all silenceable circuits (all control modules and NAC/Panel Circuits programmed as silenceable)
- Turns off the ALARM SILENCE LED
- Sends a "Manual Evacuate" message to the LCD display, the History buffer, installed Terminal Mode LCD-80s, and installed printers

System Reset



■ **Purpose** Press the SYSTEM RESET key to reset the control panel to normal operation (refer to “How to Operate the Panel in Normal Operation” on page 107).

■ **Operation** Pressing the SYSTEM RESET key resets the control panel by doing the following:

- Turns off all alarm-activated control or relay modules and NAC/Panel Circuits;
- Breaks resettable power to four-wire detectors;
- Sends an “All Systems Normal” message to the LCD display, History buffer, installed Terminal Mode LCD-80s, and installed printers; and
- Turns on all LEDs, the panel sounder, and LCD display segments for as long as the SYSTEM RESET key is held (lamp test).

Note: Any alarm or trouble that exists after System Reset will resound the system.

4.2.5 How to Read System Status LED Indicators

The Membrane Switch Panel (see Figure 97 on page 102) contains six System Status LED Indicators. The following provides the functions of each LED, the conditions that cause each LED to light (steady and flashing), and how to turn off each LED.

AC Power

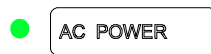

■ **Function** The AC POWER green LED lights **steady** if AC power is applied to the control panel.

■ **When it lights** When you apply AC power to the control panel.

■ **To turn off** Disconnect AC power to the control panel.

Fire Alarm



■ **Function** The FIRE ALARM LED indicates the non-acknowledged fire alarm exists in the system.

■ **When it lights** The FIRE ALARM LED **flashes** when one or more non-acknowledged fire alarms occur. The FIRE ALARM LED lights **steady** when you press the ACKNOWLEDGE/STEP key.

■ **To turn off** Press the SYSTEM RESET key.

Pre-Alarm Warning



■ **Function** The PRE-ALARM WARNING LED indicates that a programmed Pre-Alarm level is reached. For details on Pre-Alarm, refer to Appendix G “Pre-Alarm (AWACSTM) Applications”.

■ **When it lights** The PRE-ALARM WARNING yellow LED **flashes** when a non-acknowledged fire Pre-Alarm threshold is reached. The LCD display indicates if it is an Alert or Action Pre-Alarm.

■ **To turn off** To turn off the PRE-ALARM WARNING LED, clear the pre-alarm condition. Clearing an Action Pre-Alarm requires a system reset.

Supervisory Security



■ **Function** The SUPERVISORY SECURITY LED indicates one or more security conditions in a combination fire/security protective signaling application. (For more details on security applications, refer to Appendix E.)

■ **When it lights** The SUPERVISORY SECURITY yellow LED **flashes** when one or more non-acknowledged supervisory alarm (such as a sprinkler valve tamper condition) occurs. The SUPERVISORY SECURITY LED also lights **steady** when you press the ACKNOWLEDGE/STEP key.

■ **To turn off** Press the SYSTEM RESET key.

Alarm Silence



■ **Function** The ALARM SILENCE LED indicates that the ALARM SILENCE key is pressed.

■ **When it lights** The ALARM SILENCE yellow LED lights **steady** when an alarm condition occurs **and** the ALARM SILENCE key is pressed.

■ **To turn off** The ALARM SILENCE LED turns off when you press the DRILL key or the SYSTEM RESET key.

System Trouble



■ **Function** The SYSTEM TROUBLE LED indicates one or more trouble conditions in the system.

■ **When it lights** The SYSTEM TROUBLE yellow LED flashes when one or more troubles occur and goes steady when you press the ACKNOWLEDGE/STEP key. This LED also lights (flash or steady) if the microprocessor watchdog timer fails (CPU FAIL).

■ **To turn off** Clear all trouble conditions.

4.3 How to Operate the Control Panel

This section contains instructions for operating the control panel under the following operating conditions:

- Normal Operation
- Fire Alarm Operation
- Trouble Operation
- Supervisory Operation

4.3.1 How to Operate the Panel in Normal Operation

“Normal operation” refers to a control panel that is operating normally—no alarms or troubles in the system and the “All Systems Normal” message appears in the LCD display. Figure 100 shows a typical screen that appears with the control panel in normal operation:

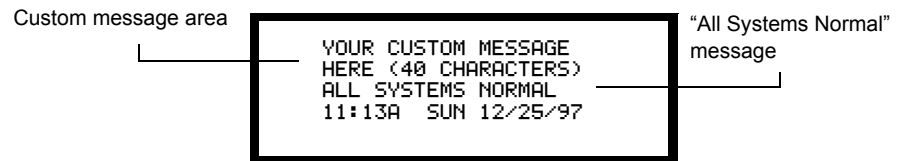
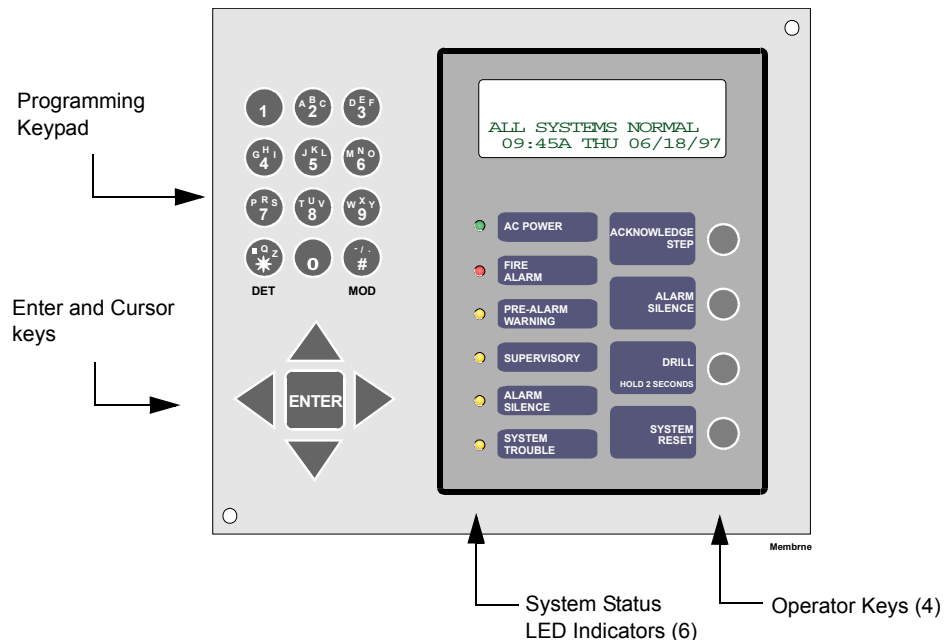

Figure 100 Typical Display Message During Normal Operation

The control panel does the following functions at regular intervals when in normal operation:

- Polls all devices connected to the SLC and the four NAC/Panel Circuits for valid replies, alarms, supervisory, and trouble signals
- Checks for power supply troubles and batteries every 10 seconds
- Sends a supervisory query on the LCD-80 interface and verifies proper response
- Refreshes the LCD display and Terminal Mode LCD-80 display and updates time
- Scans the programming keypad for System Reset or Enter
- Auto tests detectors
- Tests system memory



4.3.2 How to Operate a Panel with a Trouble Condition

What is a Trouble Condition?

A control panel indicates a trouble condition when a trouble—for example, a short circuit or ground fault—exists in the fire alarm system. If all troubles clear and no supervisory or fire alarms exist in the system, the control panel returns to a normal operation, and sends an “All Systems Normal” message to the LCD display, LCD-80, History buffer, and printer. This trouble restore occurs even if the troubles were never acknowledged (auto restore).

During a Trouble operation the control panel does the following:

- Sounds a pulsed tone.
- Flashes the SYSTEM TROUBLE LED.
- Activates the trouble relay.
- Sends a trouble message (see Figure 101 for a sample message) to the History buffer, to installed Terminal Mode LCD-80s, and to installed printers.

How the Panel Displays a Trouble

Figure 101 shows a sample trouble message for a module in trouble that appears on LCD display during trouble operation.

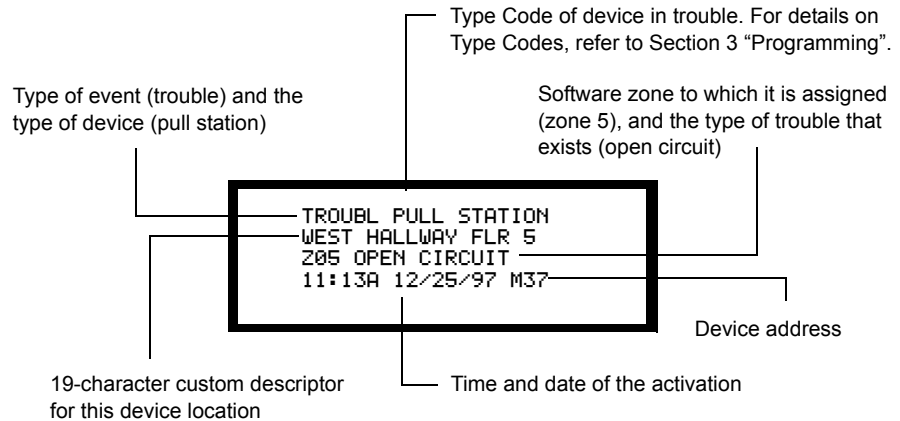

Figure 101 Sample Display of a Trouble Message

For example, in Figure 101, the M37 address represents module number 37. If the device in trouble was a detector, the “M” of address M37 is replaced with a “D”.

To Respond to a Trouble

If a trouble occurs, press the ACKNOWLEDGE/STEP key to silence the panel sounder and change the System Trouble LED from flashing to steady. If multiple troubles exist, pressing the ACKNOWLEDGE/STEP key silences all signals (block acknowledge). When pressing the ACKNOWLEDGE/STEP key and at least one new alarm or trouble exists in the system, an Acknowledge message is sent to the History buffer, installed printers, and installed Terminal Mode LCD-80s.

If the trouble clears before or after an acknowledge, the clear trouble message is sent to the printer. Figure 102 shows an example of a clear trouble message sent to the printer:

```
CLR TB PULL STATION WEST HALLWAY FLR 5 Z05 OPEN CIRCUIT 11:13A 12/25/97 M37
```

Figure 102 Sample Clear Trouble Message

If all troubles clear and no supervisory or fire conditions exist in the system, the control panel returns to a normal operation, and sends an “All Systems Normal” message to the LCD display, LCD-80, History buffer, and printer. This trouble restore occurs even if the troubles were never acknowledged (auto restore).

Pressing the ALARM SILENCE key when only troubles exist, produces the same effect as pressing the ACKNOWLEDGE/STEP key. The ALARM SILENCE LED does not light unless an alarm also exists in the system. For details on Alarm Silence, refer to “Alarm Silence” on page 106.

If multiple trouble conditions exist in the system, the LCD display and installed Terminal Mode LCD-80 display steps through each trouble automatically at a two-second rate. If you press the ACKNOWLEDGE/STEP key, the LCD display stops on the current trouble for 1 minute, then begins to automatically step through events in the following order:

1. Alarms, in order of address.
2. Supervisory, in order of address, or security alarms.

Control modules report both open and short circuit messages for their NAC.

3. Troubles, in order of address.

To manually step through events, press the ACKNOWLEDGE/STEP key.

4.3.3 How to Operate a Panel with a Trouble Monitor Point

Trouble Monitor points are monitor modules that monitor remote power supplies or other external equipment for short circuits. These types of monitor modules operate like monitored system functions that can produce troubles, but with the following differences:

- The display status banner is ACTIVE.
- The type code is TROUBLE MON. For more information on monitor module Type Codes, refer to Section 3 “Programming”.
- The monitor modules latch until the trouble condition(s) is cleared to normal operation and the system is reset.
- The monitor modules can have Control-by-Event (CBE).

Figure 103 shows a sample message for a monitor module with a Trouble Monitor Point Type Code that appears on LCD display during trouble operation.

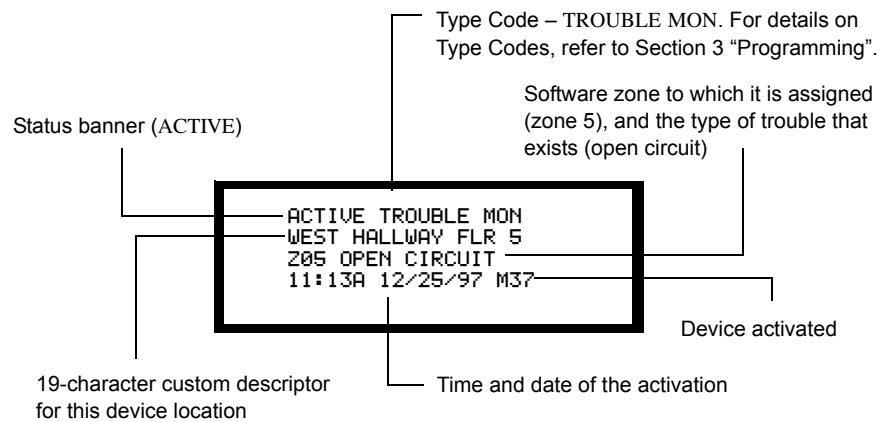

Figure 103 Sample Display of a Message for a Trouble Monitor Point

4.3.4 How to Operate a Panel with a Fire Alarm

What is a Fire Alarm?

A fire alarm is a signal indicating an emergency condition that requires immediate attention. Fire alarms result from sources such as a manual pull stations and smoke detectors.

How the Panel indicates a Fire Alarm

When a fire alarm occurs, the control panel goes into a fire alarm condition. Figure 104 shows a sample LCD display for a control panel when a detector goes into alarm:

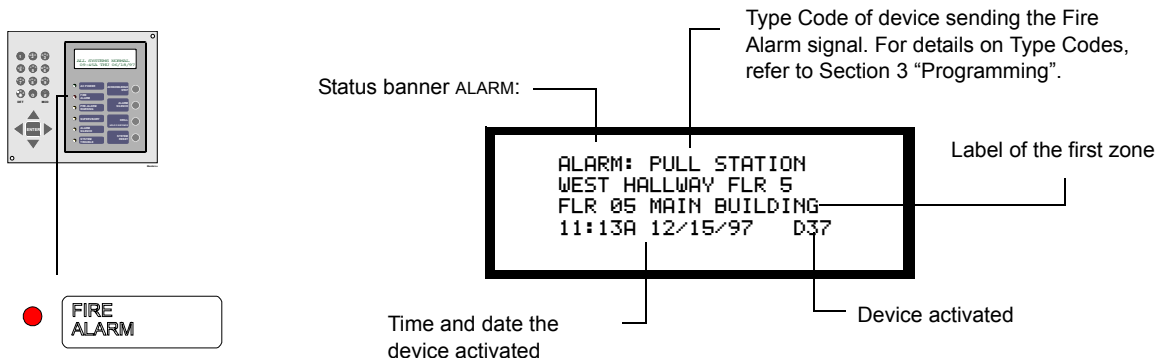

Figure 104 Sample Display for an Fire Alarm

A control panel in Fire Alarm operation does the following:

- Activates the panel sounder with a steady sound.
- Flashes the FIRE ALARM LED.
- Displays a status banner of ALARM along with specific information about the activated device as shown in Figure 104.
- Latches the device in alarm until the alarm condition is cleared and the system is reset. Refer to “System Reset” on page 105.
- Recalculates all Control-by-Event.
- Starts all timers, such as Silence Inhibit and Auto Silence.
- Activates the general alarm relay and general alarm zone Z00.

4.3.5 How to Operate a Panel with a Supervisory Condition

What is a Supervisory Condition?

A **Supervisory** is a signal indicating a need to respond to events such as supervision of a guard tour, a sprinkler, and so on.

How the Panel Indicates a Supervisory

When a supervisory signal occurs, the control panel indicates a supervisory condition. Figure 104 shows a sample LCD display for a control panel with a supervisory signal.

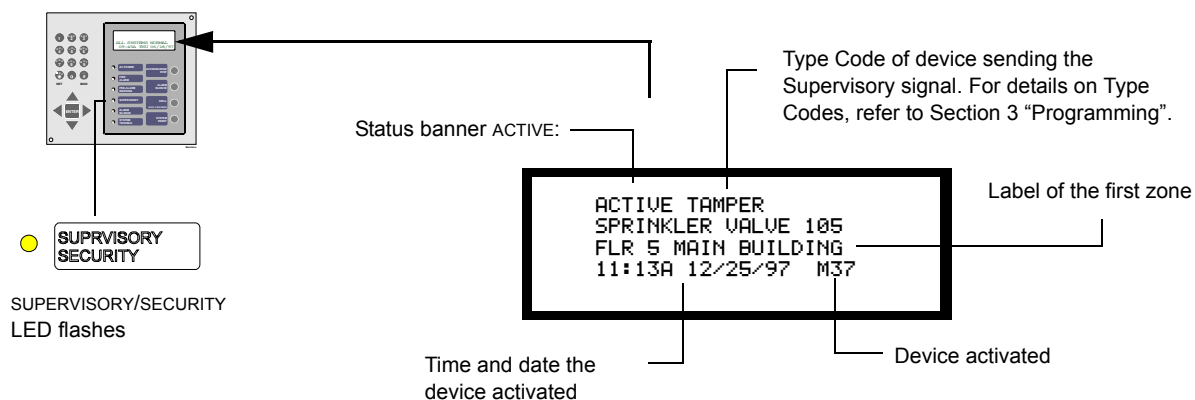

Figure 105 Sample Display for a Supervisory Signal

A control panel in Supervisory operation does the following:

- Activates the panel sounder with a warbling tone.
- Flashes the SUPERVISORY LED.
- Displays a status banner of ACTIVE along with specific information about the activated device as shown in Figure 106.
- Activates the Supervisory relay.
- Latches the device until the Supervisory signal is cleared and the system is reset.

Note: In Supervisory operation, the Alarm relay does not activate, silenced alarms do not resound nor do they reactivate silenced alarm CBE, and timers do not start.

Supervisory signals track and may have their own Control-by-Event. They do not cause resound of alarms or reactivation of silenced alarm CBE. Supervisory circuits may also report open circuit troubles, which operate like any other trouble. If the event is a security point activation, this LED will operate the same as a supervisory, but the LCD display will show the security type code. Refer to Appendix E for further information on security alarms.

4.3.6 How to Operate a Panel with a Non-Alarm Condition

What is a Non-Alarm Condition?

A **Non-Alarm** condition results when a monitor module programmed with one of the three Non-Alarm type codes (see Table 34) activates. Non-Alarm points activate their programmed CBE—but do not activate the SYSTEM ALARM LED or the panel sounder.

How the Panel indicates a Non-Alarm Condition

When a Non-Alarm signal occurs, the control panel changes the status banner to ACTIVE. Figure 106 shows a sample LCD display for a control panel with a Non-Alarm condition.

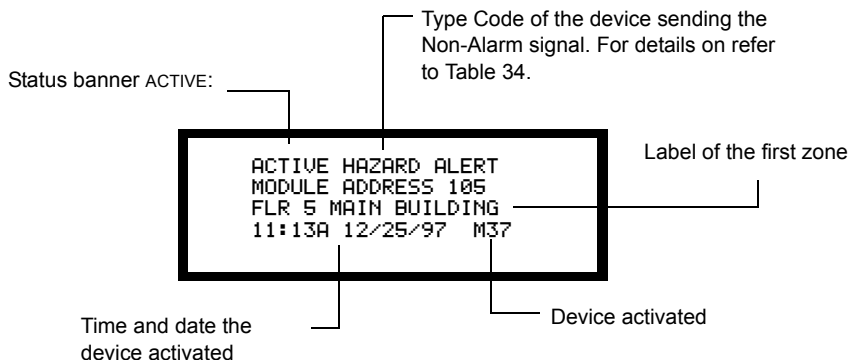

Figure 106 Sample Display for an Non-Alarm Condition

Table 34 contains descriptions of Non-Alarm Type Codes:

If the LCD Display shows this Type Code	The control panel does the following
NON FIRE	Does not send a message to the LCD display, the History buffer, installed printer, or installed Terminal Mode LCD-80.
HAZARD ALERT	<ul style="list-style-type: none"> Sends a message to the LCD display, History buffer, installed printer, and LCD-80 (status is ACTIVE) and Activates the four NACs steadily—regardless of the coding selection in Zone 98. For more information on coding, refer to “Coding Operation (NAC only)” on page 117. Sounds the local piezo and lights the supervisory LED.
FIRE CONTROL	Send messages to the LCD display, History buffer, installed printers and installed Terminal Mode LCD 80s—regardless of the state of the control panel.

Table 34 Non-Alarm Point Type Codes

4.3.7 How to Operate the Panel with an Output Circuit Trouble

Output circuits include the four Panel Circuits connected through TB2 and control or relay modules connected through the SLC via TB6. Output circuits have Control-by-Event and trouble functions. Panel Circuits differ from control or relay modules in the following ways:

- Addresses (last three digits in LCD field) are B01, B02, B03 or B04.
- The default Type Code field is BELL CIRCUIT.
- They may be used for March Time, California Code, Temporal, and Two Stage coded functions.

4.3.8 How the Control Panel Indicates a Panel Circuit Trouble

- The SYSTEM TROUBLE LED flashes
- Trouble relay turns on
- A message is sent to the LCD display, History buffer, and installed printers, terminal mode LCD-80s, and CRT-2s
- A TROUBL status banner and a BELL CIRCUIT Type Code is displayed on the LCD display, along with information specific to the device, as shown in Figure 107.

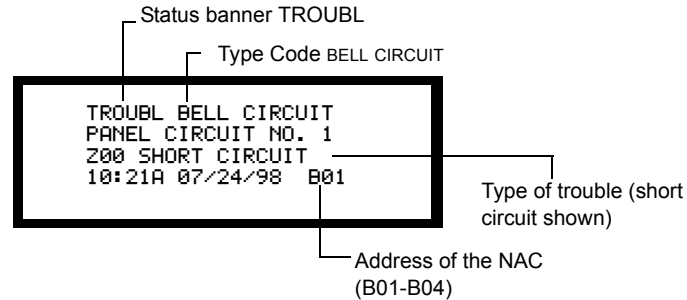

Figure 107 Sample Display of a Panel Circuit in Trouble

4.4 Control-By-Event Operation

Control-by-event (CBE) is done through 99 software zones. Each system point (detector, control module, monitor module, relay module, or NAC) may list up to five zones in its program information. A general alarm zone (Z00) may be listed for output (control) points, but is not necessary to list for input points. Z00 is not activated by non-alarm or supervisory points.

If any input device (detector or monitor module) becomes active and it is not disabled, it activates all software zones in its list. An output device (control or relay module, or NAC) that is not disabled is turned on if any of the software zones in its list are active. This is basically an “or” functionality. Zones 90 through 99 are reserved for special functions such as releasing (Refer to Section 3 “Programming”).

Control-by-event (CBE) control is done through 99 software zones. Each input point (detector, monitor module) and output point (control or relay module, NAC/Panel Circuit) can be programmed to list up to five software zones. Non-Alarm or Supervisory points do not activate software zone Z00 (general alarm).

Zones 90-99 are reserved for special functions such as releasing (refer to Section 3 “Programming”).

Input and output devices with listed software zones work as follows:

- Inputs – When an input device (detector or monitor module) activates, so do all software zones listed to the input device.
- Outputs – When a software zone activates, the output device (control or relay module, NAC/Panel Circuit) turns on.

Figure 108 shows an illustration of simple CBE for Zone 04.

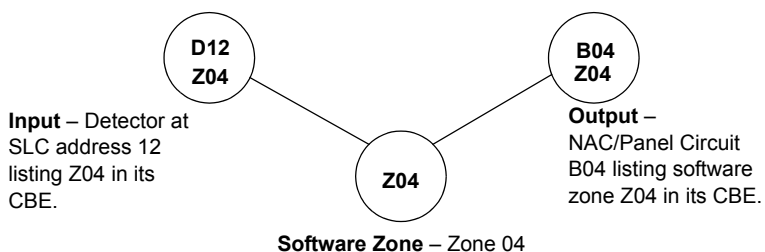

Figure 108 CBE Example

In Figure 108, the input device (detector D12) lists zone Z04 and the output device (B04) both lists zone Z04 in their CBE. If Detector D12 activates: Zone Z04 activates, which causes the device connected to B04 to activate.

4.5 Releasing Functions

4.5.1 Overview

Zones 91-94 are reserved for releasing zones—providing up to four independent releasing operations. Each releasing zone includes the following options:

Option	Description
Cross-zoning	Select one of three types of cross-zoning. Refer to Table 36.
Delay Timer	Select a 0–60 second delay before activating a zone.
Abort	An abort switch-type code used to abort activation of a zone.
Manual Release	Allows immediate zone activation by overriding the abort function, cross-zone function, and delay timer.
Soak Timer	Automatically shuts off the releasing device. Select 10-15 minutes for a Soak Timer or zero for no Soak Timer.

Table 35 Cross Zoning Options



WARNING: When used for CO₂ releasing applications, observe proper precautions as stated in NFPA 12. Do not enter the protected space unless physical lockout and other safety procedures are fully completed. Do not use software disable functions in the panel as lockout.



WARNING: Use only SLC control module outputs for agent releasing applications.

4.5.2 How to Select Cross Zone Options

The Cross Zone options lets you program the control panel to activate a releasing zone after two initiating devices activate. (If not using Cross Zoning, set CROSS= to N as shown in Figure 141 on page 148.) Table 36 contains a summary of the types of cross zoning and the conditions for activating a releasing zone.

Type	Activates when
N	Cross zoning not selected.
Y	Two or more detectors, all mapped to one of the four releasing zones (91-94) activate.
Z	Two or more detectors, mapped to two different software zones and one of the four releasing zones (91-94) activate.
H	At least one smoke detector and at least one heat detector, all mapped to one of the four releasing zones (91-94) activate.

Table 36 Cross Zoning Types

Figure 109 shows an example of one heat detector, three smoke detectors, and an SLC control module connected to a releasing circuit mapped as a releasing zone, using cross zoning:

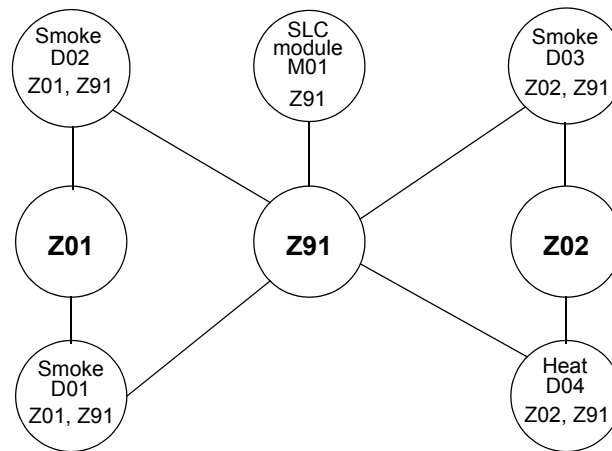

Figure 109 Cross Zoning Example

Only the first non-special zone listed in the zone map is used to determine Cross=Z.

■ **Cross Zoning Example** Table 36 lists examples of devices mapped to releasing zones.

The following explanations apply to the examples shown in Figure 109:

- **Cross=N** An alarm from any detector activates the releasing module circuit.
- **Cross=Y** An alarm from any two detectors activates the releasing module circuit.
- **Cross=Z** Release requires the activation of two detectors mapped to different zones: D01 and D02 cannot activate the releasing module circuit because both detectors are mapped to Z01; D01 and D03 can activate the releasing module circuit because they are mapped to different zones.
- **Cross=H** Release requires activation of heat detector D04 and one smoke detector (D01, D02, or D03).

4.6 Releasing Functions

Zones 91, 92, 93, and 94 are reserved for special releasing functions. This allows for up to four simultaneous release operations (quad hazard). Each zone includes the following:

- **Cross Zone** will activate only if two or more fire type input points are activated that list this zone. In addition, there are two other types of cross-zones: one cross zone requires that the two devices reside in different zones; and the other requires that the two devices are a smoke detector plus a heat detector.
- **Delay timer** – A timer that allows the selection of a 0 to 60 second delay before the zone can activate.
- **Abort switch** – type code in a given zone is used to abort activation of the zone.
- **Manual Release** – overrides the abort function, cross-zone function, and delay timer, and activates the zone immediately.
- **Soak** – a Soak timer automatically shuts off the releasing device. Select 10 through 15 minutes (or zero for no timer).

A hazard is protected by assigning one of the four zones to each initiating device, abort switch, manual release switch, and release solenoid. Refer to Appendix D for detailed information about releasing applications.

4.7 Intelligent Detector Functions

4.7.1 Summary of Detector Functions

Table 37 contains a summary of functions for intelligent detectors used with the control panel.

Function	Description
Analog Display	The control panel reads and displays analog information from the 99 analog detectors. The display shows the percent of the alarm threshold for each detector.
Day/Night Sensitivity Operation	You can program the system to automatically force smoke detectors to minimum sensitivity during the day. For more information, refer to "Time Functions" on page 116.
Maintenance Alert	When compensation reaches the limit of the amount of drift compensation that can be safely applied, the control panel reports a special trouble condition, per national fire code standards. This condition also activates if the detector remains at very high or very low levels for an extended time.
Automatic Test Operation	The control panel performs an automatic test of each detector every 256 minutes. Failure to meet the test limits causes an "Detector Test Fail" trouble.
Type Code Supervision	The control panel monitors hardware device type codes (FSI, FSP, FST, monitor module, control module, and relay module) for each installed device at regular intervals (an interval can take up to 30 minutes for full capacity system). If a mismatch of type compared to the program occurs, the control panel generates a point trouble labelled INVALID TYPE.
LED Control Operation	A global program selection to prevent detector LEDs from blinking during normal operation. A typical application is in a sleeping area where a blinking light can distract people. As a standard function, the control panel allows all LEDs to turn on in alarm.
Alarm Verification and Counter Operation	The control panel performs alarm verification on programmed FSI and FSP intelligent smoke detectors. The verification time is a global program selection of 0–30 seconds. Each detector includes a verification counter, which displays the number of times that a detector entered verification but did not time-out to alarm. The counter increments to 99 and holds.

Table 37 Intelligent Detector Functions

4.7.2 Pre-Alarm Operation/Advanced Warning Addressable Combustion Sensing (AWACS™)

If a photo or ionization detector exceeds the programmed Pre-Alarm level, a Pre-Alarm condition occurs: the panel sounder and zone 99 activate; and the PRE-ALARM WARNING LED lights. Figure 110 shows a typical message that is sent to the control panel LCD, LCD-80, printer and History buffer.

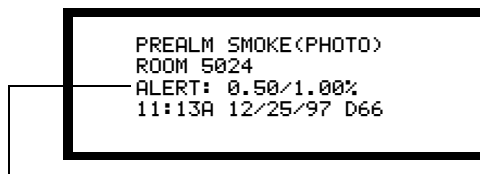

This example shows a detector programmed for alarm at 1.00% per foot (30.48 cm) of obscuration (High level). The 50% indicates that the detector is at the Alert level programmed for 50% of that, or 0.50% per foot (30.48 cm). The 50% is a real-time display and may change. Alert Pre-Alarms automatically restore.

Figure 110 Typical Display for a Pre-Alarm Alert Event

An Action Pre-Alarm is indicated if a detector exceeds the Action level threshold. When this occurs, all functions of the Alert level occur, plus a special Action software zone (5th zone) may be activated if programmed. Action Pre-Alarms latch until reset. Figure 111 shows a typical Action Pre-Alarm display:

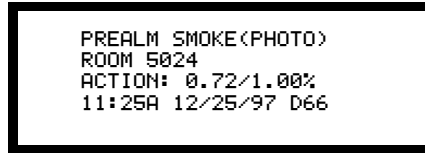

Figure 111 Typical Display for a Pre-Alarm Action Event

4.8 Time Functions

4.8.1 Overview

The control panel includes a real-time clock that provides time-of-day, date, and day-of-week. The clock includes a lithium battery backup. Time normally displays in a 12-hour time format with month/day/year. Table 38 contains descriptions and typical uses for time functions.

Time Function	Description	Typical Uses
Time Control Command	ZONES 95 and 96 are reserved for control-by-time special functions, intended for ancillary (non-fire) applications (such as lighting control, setting a thermostat, and so forth).	For example, program ZONES 95 and 96 to activate at one time of day and deactivate at another time, on certain days of the week. You can turn a non-fire control point on and off, by using ZONE 95 or 96.
Day/Night Sensitivity Adjust	If an FSI or FSP detector CBE lists ZONE 95 or 96, the control panel sets the detector sensitivity to the minimum (low) setting when ZONE 95 or 96 is activated by the programmed date/time in its CBE. When ZONE 95 or 96 deactivates, the detector sensitivity returns to the programmed setting.	For day/night sensitivity use, consider ZONES 95 and 96 as Day ZONES.
Holiday	The control panel reserves ZONE 97 for setting holiday dates (up to 9 days). When the current date matches any of the nine holiday dates, the control panel activates ZONE 97.	Other uses for zone 97 include: a special day-of-year control; or an 8th day in programming ZONES 95 and 96.

Table 38 Control Time Functions

4.8.2 Coding Operation (NAC only)

Zone 98—reserved for NAC coding functions—is only used by NACs listing zone 98. You can select one of the four code types listed in Table 39:

Code	Signal
March Time (default)	120 PPM (Pulses Per Minute)
Two-Stage	Alert signal – 20 PPM; General alarm signal: Temporal
Two-Stage Canada 3	Alert signal – 20 PPM; Drill Switch: Temporal Timer: 3 minutes
Two-Stage Canada 5	Alert signal – 20 PPM; Drill Switch: Temporal Timer: 5 minutes
California	10 sec. on, 5 sec. off, repeats
Temporal	0.5 on, 0.5 off, 0.5 on, 0.5 off, 0.5 on, 1.5 off, repeats

Table 39 Zone 8 Type Codes

Notes on using coding functions:

- **Control Modules.** Zone 98 does not work if listed in the CBE of control modules.
- **Two-Stage.** When an alarm occurs, an NAC programmed for two-stage, and not activated by another zone, pulses at 20 PPM. After 5 minutes, the NAC changes to Temporal unless you press the ACKNOWLEDGE/STEP key. Pressing the DRILL key on the control panel changes the NAC pulse to Temporal pattern.
- **Two-Stage Canada.** Functions like standard Two-Stage except only the Manual Evacuate will cause NAC to go to second stage. If acknowledge is pressed on first stage, timer will not time out. Subsequent alarm will restart timer.

4.8.3 Presignal/PAS Operation

Zone 90 is reserved for pre-signal functions and is used to delay control points for human verification. If zone 90 is included in a control or relay module or Notification Appliance Circuit's CBE list, it inhibits all other CBE. Detectors and Monitor Modules must call out Zone 90 in their program to be included in the pre-signal/PAS operation.

When any alarm occurs and no PAS inhibit type monitor module is activated, Zone 90 activates. If a second alarm activates, or the DRILL key is pressed, Zone 90 goes false. If PAS is selected, and the Acknowledge key is not pressed within 15 seconds, Zone 90 goes false. At the first alarm, a programmable 0–180 second timer starts. If an Alarm Silence occurs, the timer stops. If the delay timer expires, manual activation will activate outputs mapped to Zone 90. The System Alarm relay, the 4XTM Polarity Reversal Alarm Output, and the 4XTM Municipal Box Output delay if PAS is selected, but do not delay for Presignal operations.

4.8.4 Special System Timers

The control panel can operate with special system timers: Silence Inhibit, Auto Silence, and Alarm Verification. Table 40 contains descriptions of how each timer works.

Timer	Duration	If selected
Silence Inhibit	0-300 seconds	Starts at first alarm and restarts with each new alarm. Disables the ALARM SILENCE key.
Auto Silence	600-900 seconds(0=no timer selected)	Automatically shuts off outputs selected as silenceable after the programmed time elapses. To restart the timer, press the DRILL key.
Alarm Verification	0-30 seconds	The control panel ignores an FSI or FSP smoke detector for the Alarm Verification time. If another point alarm occurs during the Alarm Verification time, the control panel dumps the timer and activates the alarm. If a time-out and an alarm exist, the initiating device CBE executes all standard functions. If at time-out an alarm no longer exists in the alarm initiating device, the control panel increments a verification counter (1-99) for the device and returns to normal operation.

Table 40 Special System Timers

4.8.5 Waterflow Circuits Operation

If an alarm exists from a monitor module point that has a Waterflow type code, the ALARM SILENCE key will not function.

4.8.6 Disable/Enable Operation

Disabled input points do not cause an alarm or any Control-by-Event activity. The control panel does the following:

- Holds all disabled output points in the off-state
- Handles all disabled points as troubles, but displays DISABL in the status banner.

4.8.7 Style 6 Operation

The control panel will detect a trouble in an SLC wired and programmed for Style 6 or Style 7 and drive both ends of the line to maintain communication over the SLC. The trouble latches and displays on the control panel as a Style 6 trouble type until you press the SYSTEM RESET key on the control panel. Style 7 requires use of ISO-X modules.

4.9 Read Status

4.9.1 Overview

Read Status functions do not require a password. The control panel continues to provide fire protection while in Read Status. You can enter Read Status while in Fire Alarm or Trouble mode. If a new alarm or trouble occurs during Read Status functions, the control panel automatically exits Read Status.

4.9.2 How to Enter Read Status



Press the ENTER key. The control panel displays the Program Entry screen as shown in Figure 112:

```
1=PROGRAM
2=READ STATUS
<BACKSPACE TO ABORT>
```

Figure 112 Program Entry Screen



From the Program Entry Screen, press the 2 key. The control panel displays the Read Status screen as shown in Figure 113:

```
READ POINT=*/#,AA,E
PRINT POINTS=1,E
READ HISTORY=2,E
PRINT HISTORY=3,E
```

Figure 113 Read Status Screen

4.9.3 Read Status Options

If attempting to read a point that is not installed, the control panel displays NOT INSTALLED.

To do a Read Status, follow the instructions in Table 41. For explanation of history operation, refer to “Using the History Buffer” on page 124.

To	Do this
Read Point	<ul style="list-style-type: none"> Select the type of point to read: * for a detector, # for a module, or *# for a bell circuit. Enter the two-digit address of the point; then press the ENTER key.
Print Points	Press the 1 key; then press the ENTER key.
Read History	Press the 2 key; then press the ENTER key.
Print History	Press the 3 key; then press the ENTER key.

Table 41 Read Status Options

During all Read Status operations (except print operations) the control panel starts a two-minute timer each time you press a key. If the control panel does not detect a key press for two minutes, the control panel leaves the current operation and returns to the previous display.

- Press the Left cursor (Backspace) key to delete the previous entry.
- Press the left cursor (backspace) again to exit Read Status.

4.9.4 Read Point

Read Point operations display point status on the LCD display and on the terminal mode LCD-80s, but the status is not sent to the serial ports or the History buffer. After a point read, you can press the **down** key to read the next point in sequence, or press the **up** key read the previous point in sequence. The sequence of points is:

- Detector points 01-99
- Module points 01-99
- Panel Circuits 01-04
- System parameters
- Software Zones 01-89
- Special Zones 90-99

Read Point Status

Figure 114 shows an example of read point for a detector and Figure 115 shows an example of read point for a module.

■ **Detector Example** For example, to read the status of a photoelectric detector at address 13: press *, enter the address (13), then press the ENTER key. The control panel displays information about the detector as shown in Figure 114:

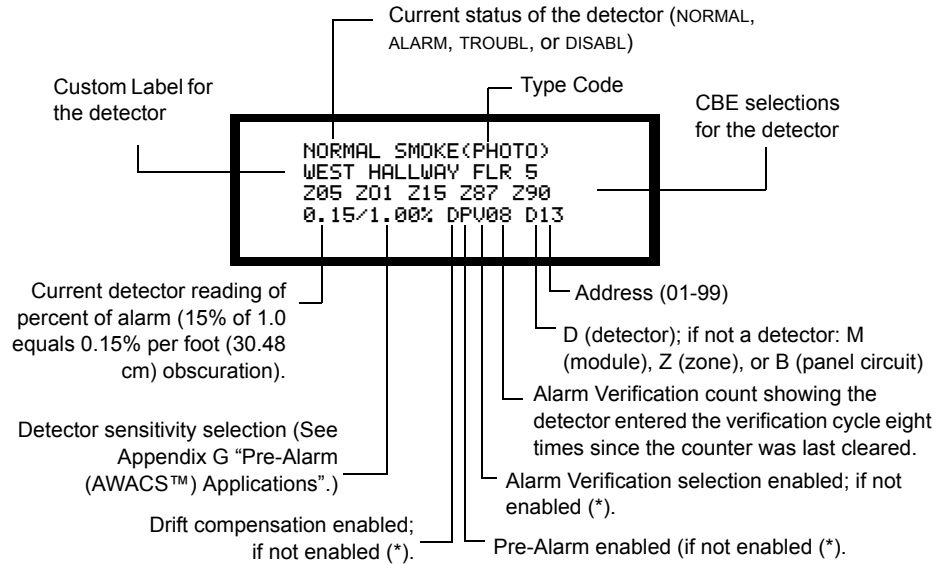
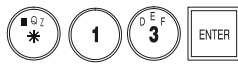

Figure 114 Detector Read Status Sample Screen

■ **Module Example** For example, to read the status of a monitor module at address 08: press #, enter the address (08), then press the ENTER key. The control panel displays information about the module as shown in Figure 115:

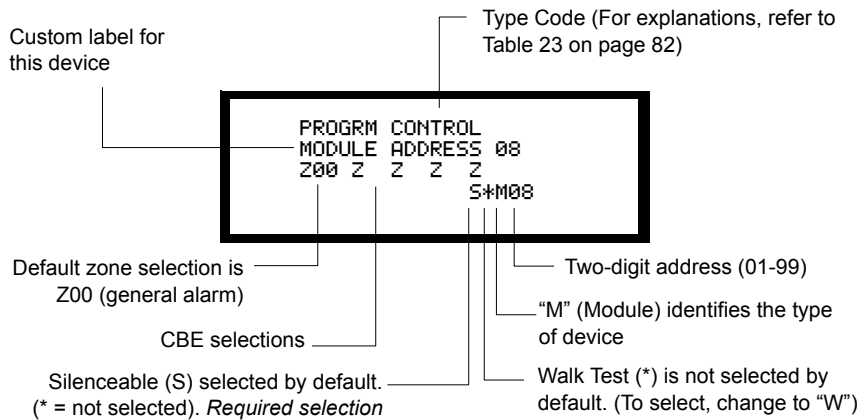

Figure 115 Module Read Status Sample Screen

Software Zones 01-89

To read the status of a zone directly, press *, press * again, then enter the two-digit zone number and press the ENTER key. Figure 116 contains a typical display that shows the status of zone 20:

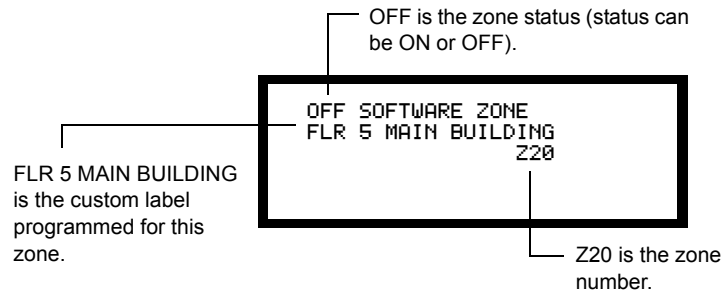
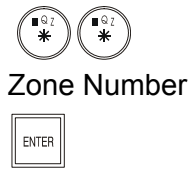

Figure 116 Typical Zone Read Status Screen

Software Zone 90

Figure 117 contains a typical display that shows the status of software zone 90 (Presignal delay control).

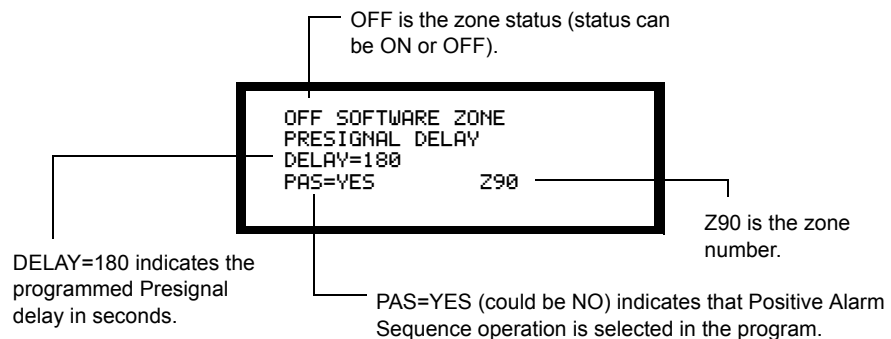
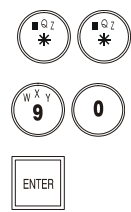

Figure 117 Typical Presignal Delay Screen

Software Zones 91, 92, 93, and 94

Figure 118 shows a typical display for the status of a releasing control zone (software zones 91, 92, 93, or 94):

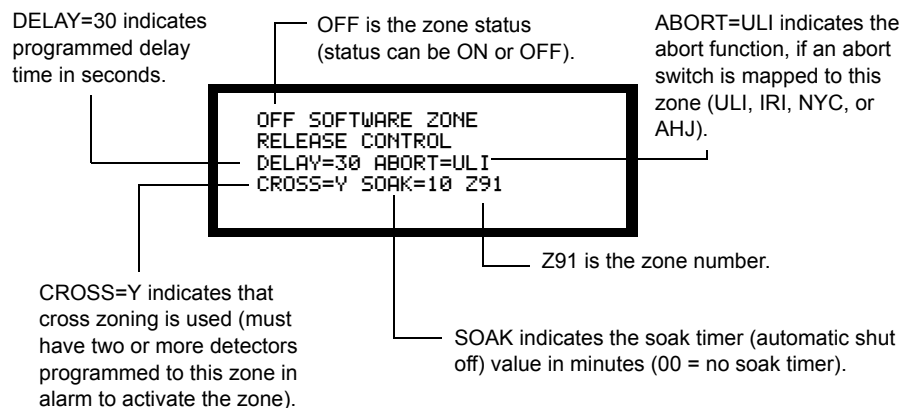
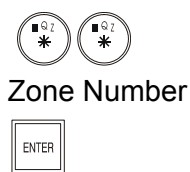

Figure 118 Typical Display for a Releasing Control Zone



Time Control – Software Zones 95 or 96

Figure 119 shows a typical display for the status of time control zone 95. In addition to automatic activation of non fire control points, this zone may be used for detector day/night sensitivity select. If day/night sensitivity is desired for a smoke detector, it must call out Zone 95 or 96 in its program. When the fire control is active, it forces the detector sensitivity to the low setting (2.0% per foot (30.48 cm) obscuration for photoelectric detector).

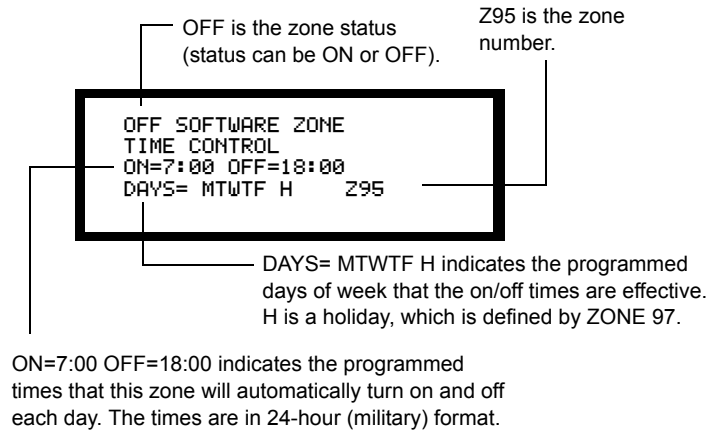
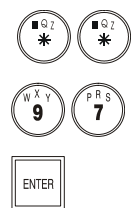

Figure 119 Typical Display for a Time Control Zone



Holiday – Software Zone 97

Figure 120 contains a typical display that shows the status of software zone 97 (Holiday zone). The day/month numbers are user-programmed holidays of the year.

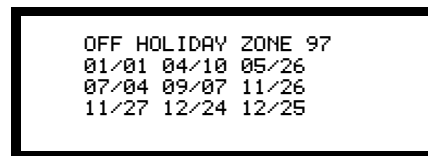
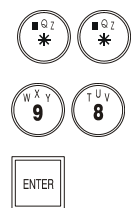

Figure 120 Typical Display for a Holiday Zone



NAC Coding – Software Zone 98

Figure 121 contains a typical display that shows the status of software zone 98 (NAC coding):

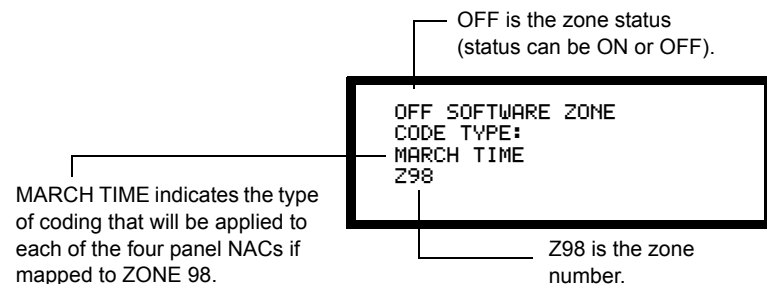

Figure 121 Typical Display for a NAC Coding Zone

Figure 121 shows NAC coding of March Time. Other possible program selections are Temporal, California, and Two-stage. For more information on coding, refer to “Coding Operation (NAC only)” on page 117.

Software Zone 99 (Pre-Alarm)

Figure 122 contains a typical display that shows the status of software zone 99 (Pre-Alarm). Zone 99 turns on if any detector reaches its Pre-Alarm threshold to indicate an incipient alarm, or the need for detector maintenance. Zone 99 can be mapped to any control point.

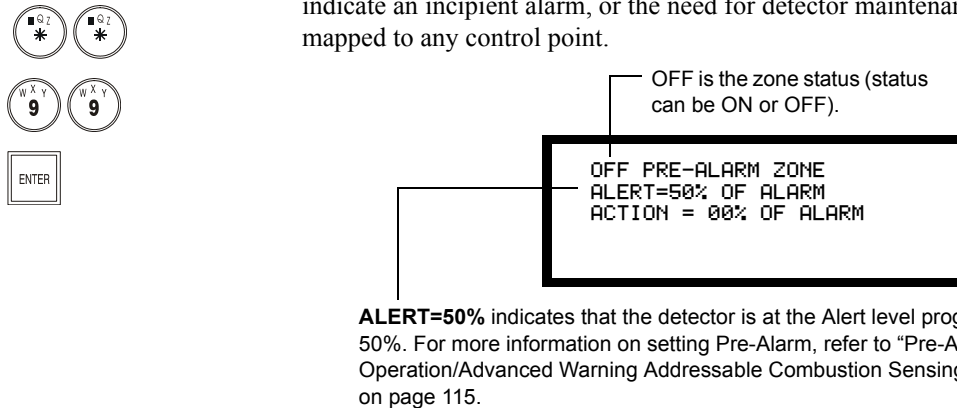

Figure 122 Typical Display of a Pre-Alarm

System Parameters

Figure 123 contains a typical display that shows System Parameters. To read the System Parameters directly, press the * key two times, then press the ENTER key.

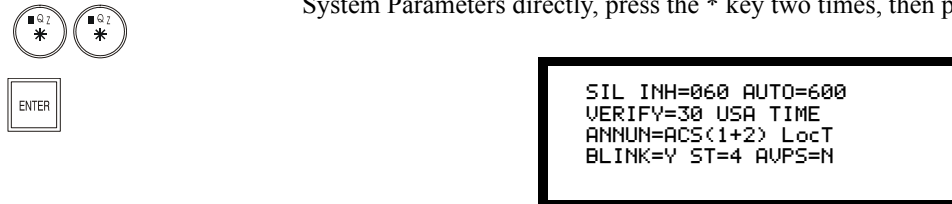

Figure 123 Typical Display of the System Parameters Screen

The following describes the items in Figure 123. For explanations of system parameters, refer to "How to Edit System Functions (7=sys)" on page 89.

- **SIL INH=060** is the Silence Inhibit time in seconds, required in Canada and some areas of the United States (SIL INH=000 indicates the timer is not selected).
- **AUTO=600** is the automatic silence timer in seconds (000=not selected).
- **VERIFY=30** is the Alarm Verification timer in seconds (00=not selected).
- **USA TIME** may be EUR TIME if European time/date display format is selected.
- **ANNUN=ACS(1+2)** indicates that the EIA-485 port (TB5) is programmed to use point annunciation (ACS family) and that both Addresses 1 and 2 are used. Other selections include ANNUN=ACS(ADDR 1), ANNUN=LCD80 (T), ANNUN=NON SUPV and ANNUN=UDACT. NON SUPV is terminal mode and is selected if no ACS annunciation is needed.
- **LocT** indicates that a local terminal (CRT-2) is connected and can be used for Acknowledge, Signal Silence, Drill, and Reset functions.
- **BLINK=Y** refers to the LEDs on intelligent devices. The blink may be suppressed for certain applications.
- **ST=4** refers to the NFPA wiring style desired for the communications loop. It can be set to Style 4 or Style 6. The ST=6 setting is used for both Style 6 and Style 7 operation.
- **AVPS=N** indicates that there is no AVPS-24/AVPS-24E or APS-6R expansion power supply installed (refer to Appendix J).

For LocT, the terminal must be in the same room as the control panel.

4.9.5 Using the History Buffer

What is a History Buffer?

The History buffer is an electronic record of the last 650 events recorded by the control panel. For information on reading or printing the History buffer, refer to “Read Status Options” on page 119. All events are time and date stamped. Events in the History buffer include the following:

For instructions on how to clear the contents of the History buffer, refer to “How to Clear the History Buffer (4=clr hist)” on page 98.

- All alarms, troubles and operator actions, such as Acknowledge, System Reset, Signal Silence, Manual Evacuate (Drill), and Walk Test.
- Each programming entry, which includes a number indicating the programming submenu (0-9).

Figure 124 shows the first display when you read history:

```

EVENT HISTORY START
<BACKSPACE TO ABORT>
EVENTS IN HISTORY : 067
*****
    
```

Figure 124 Sample Display History Buffer

When you enter Read History, the most recent event appears in the LCD display. Figure 125 shows a sequence of the first three events that appear in the LCD display:

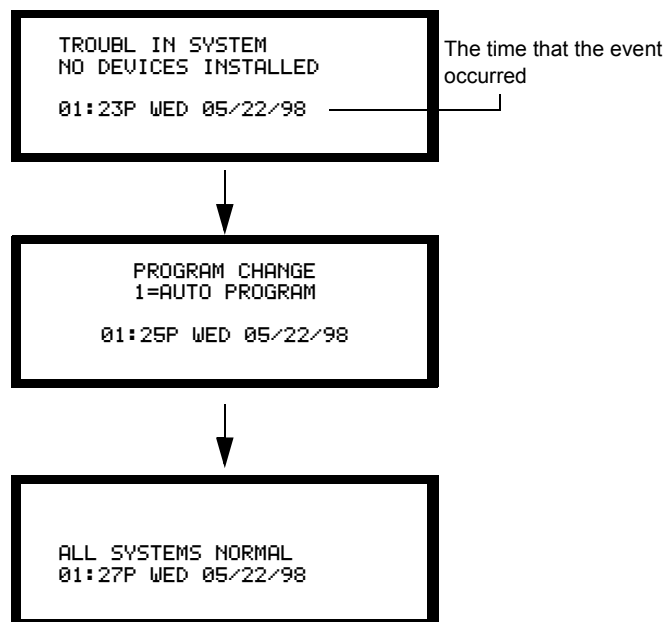

Figure 125 Sample Read History Display

Table 42 contains instructions for moving around the History buffer.



To	Press
Display earlier events	
Display later events	
Exit and return to the Read Status screen	 or the SYSTEM RESET key

Table 42 Read History Navigation Keys

What is a Shadow History Buffer?

The control panel also has a non-erasable shadow History buffer that always contains the last 650 events in time. Table 43 contains instructions for reading and printing the shadow History buffer.





To	Press
Read the shadow History buffer	 
Print the shadow History buffer	 

Table 43 How to Read and Print the Shadow History Buffer

During all Read Status operations—except print operations—a two-minute timer starts. If no key is pressed during the two-minute timer, the LCD returns to the previous display. Each key press restarts the two-minute timer.

Appendix A Power Supply Calculations

A.1 Overview

This appendix contains instructions and tables for calculating power supply currents in alarm and standby conditions. This is a four-step process, consisting of the following:

1. Calculating the total amount of AC branch circuit current required to operate the system.
2. Calculating the power supply load current for non-fire and fire alarm conditions and calculating the secondary (battery) load.
3. Calculating the size of batteries required to support the system if an AC power loss occurs.
4. Selecting the proper batteries for your system.

A.2 Calculating the AC Branch Circuit

The control panel requires connection to a separate, dedicated AC branch circuit (120 VAC for AFP-200 and 220/240 VAC for AFP-200E), which must be labeled FIRE ALARM. This branch circuit must connect to the line side of the main power feed of the protected premises. No other equipment may be powered from the fire alarm branch circuit. The branch circuit wire must run continuously, without any disconnect devices, from the power source to the fire alarm control panel. Overcurrent protection for this circuit must comply with Article 760 of the National Electrical Codes as well as local codes. Use 14 AWG wire with 600-volt insulation for this branch circuit.

Use Table 44 and Table 45 to determine the total amount of current, in AC amperes (A), that must be supplied to the system.

Device Type (amps)	Number of Devices		Current Draw	=	Total Current per Device	
AFP-200	1	X	3.0	=	3.0	
AVPS-24	[]	X	1.0	=		
APS-6R	[]	X	2.5	=		
Sum Column for AC Branch Current Required					=	A

Table 44 S120 VAC Branch Circuit Requirements

Device Type (amps)	Number of Devices		Current Draw	=	Total Current per Device	
AFP-200E	1	X	1.5	=	1.5	
AVPS-24E	[]	X	0.5	=		
APS-6R	[]	X	1.2	=		
Sum Column for AC Branch Current Required					=	A

Table 45 220/240 VAC Branch Circuit Requirements

A.3 The Main Power Supply

The control panel's main power supply can supply a total of 5.0 A in alarm and 1.0 A in standby (Non-Alarm condition). The current available for powering external devices, however, is subject to lower limits as shown in Figure 126 and Figure 127.

A.3.1 Current Limitations in Standby

Current for operating an external device in standby (Non-Alarm) is subject to the following limitations:

1. Non-resettable power (TB1, terminals 3 and 4) and resettable power (TB1, terminals 5 and 6) are limited to a combined total of 0.5 A. Using Table 47, Calculation Column 1, verify that the combined subtotal of rows 4 and 5 is less than 0.5 A.
2. The total power supply load is limited to 1.0 A. Using Table 47, verify that the total of Calculation Column 1 is less than 1.0 A.

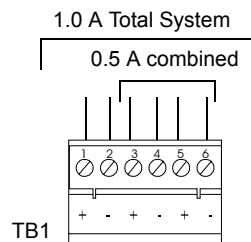

Figure 126 TB1 Standby Current Limitations

A.3.2 Current Limitations in Alarm – System Operation on Primary Power

Current for operating external devices in alarm is subject to the following limitations:

1. High ripple power (TB1, terminals 1 and 2) is limited to 1.5 A. Using Table 47 Calculation Column 2, verify that the subtotal of row 4 is less than 1.5 A.
2. Non-resettable power (TB1, terminals 3 and 4) and resettable power (TB1, terminals 5 and 6) are limited to a combined total of 0.5 A. Using Table 47 Calculation Column 2, verify that the subtotal of rows 5 and 6 combined is less than 0.5 A.
3. The maximum load on NAC 1 (TB1, terminals 1 and 2) cannot exceed 2.5 A. Using Table 47 Calculation Column 2, verify that the subtotal of row 7 is less than 2.5 A.
4. The maximum combined load on NAC 2, NAC 3, and NAC 4 (TB2, terminals 3-8) cannot exceed 2.5 A. Using Table 47 Calculation Column 2, verify that the subtotal of row 8, 9, and 10 is less than 2.5 A.
5. The total power supply load is limited to 5.0 A. Using Table 47, verify that the subtotal for Calculation Column 2 is less than 5.0 A.

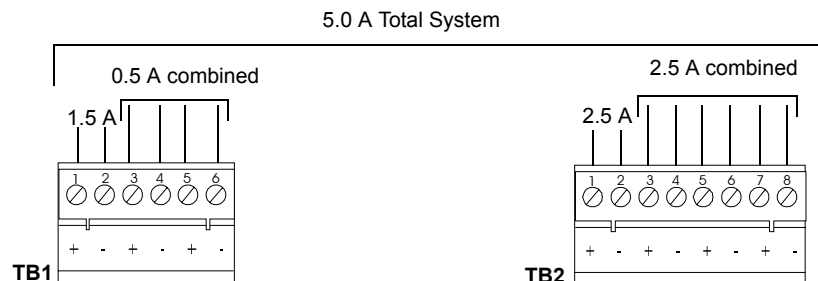

Figure 127 TB1 and TB2 Alarm Current Limitations

A.4 Calculating the System Current Draw

A.4.1 Overview

The control panel must be able to power all internal and external devices continuously during the non-fire alarm condition. To calculate the non-fire alarm load on the system power supply when primary power is applied, use Calculation Column 1 in Table 47. The control panel must support a larger load current during a fire alarm condition. To calculate the fire alarm load on the power supply, use Calculation Column 2 in Table 47. The secondary power source (batteries) must be able to power the system during a primary power loss. To calculate the non-fire alarm load on the secondary power source, use Calculation Column 3 in Table 47.

When calculating current draw and the battery size, note the following:

- “Primary” refers to the main power source for the control panel.
- “Secondary” refers to the control panel's backup batteries.
- All currents are given in amperes (A). Table 46 shows how to convert milliamperes and microamperes to full amperes.

To convert....	Multiply	Example
Milliamperes (mA) to amperes (A)	mA x 0.001	3 mA x 0.001= 0.003 A
Microamperes (µA) to amperes (A)	µA x 0.000001	300 µA x 0.000001= 0.0003 A

Table 46 Converting to Full Amperes

A.4.2 How to Use Table 47 to Calculate System Current Draws

Use Table 47 to calculate current draws as follows.

1. Enter the quantity of devices in all three columns.
2. Enter the current draw where required. Refer to the Notifier Device Compatibility Document for compatible devices and their current draw.
3. Calculate the current draws for each in all columns.
4. Sum the total current for each column.
5. Copy the totals from column 2 and column 3 to Table 48 on page 131.

Figure 128 shows the types of current that you enter into Table 47:

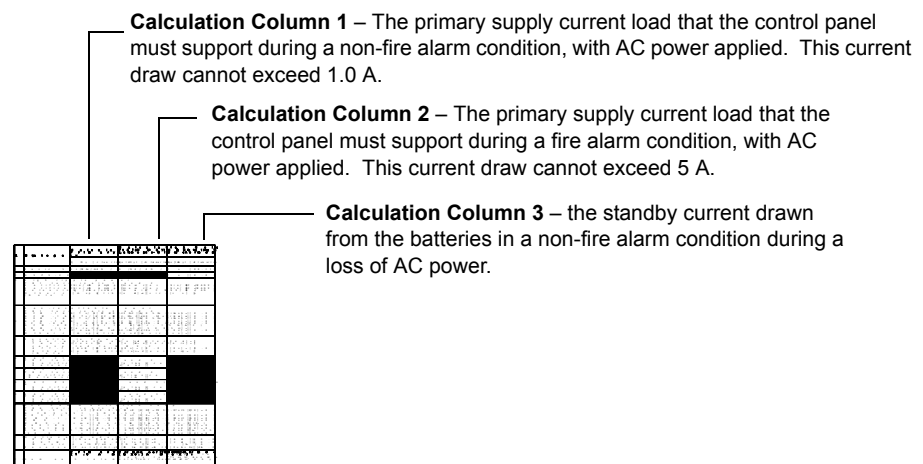

Figure 128 Calculating the System Current Draws

Table 47 contains three columns for calculating current draws. For each column, calculate the current and enter the total (in amps) in the bottom row. When finished, copy the totals from Calculation Column 2 and Calculation Column 3 to Table 48 on page 131.

Notes for Table 47:

1. Refer to the Notifier Device Compatibility Document for compatible devices and their current draws.
2. For non-English language systems, the LCD-80TM (Terminal Mode) standby current is 0.100 A.
3. Do not enter current for NAC #3 and NAC #4 in Table 47 if powering these circuits from an AVPS-24 or APS-6R. For more information on the AVPS-24 and APS-6R, refer to Appendix J.
4. The RTM-8 alarm current is based on all eight alarm relays being activated. The alarm current can be reduced by 0.019 A for each zone (between zone 1 and zone 8) that is not used by the system.
5. Enter in Column 2: "number of MMX-2 plus FZM-1" multiplied by 0.090

Row	Category	Calculation Column 1 Primary, Non-Fire Alarm Current (amps)			Calculation Column 2 Primary, Fire Alarm Current (amps)			Calculation Column 3 Secondary, Non-Fire Alarm Current (amps)		
		Qty	X [current draw]=	total	Qty	X [current draw]=	total	Qty	X [current draw]=	total
1	Basic System	N/A	N/A	N/A	1	X [0.240]=	0.240	1	x [0.10]	0.10
2	APS-6R							[]	x [0.025]=	
3	AVPS-24							[]	x [0.009]=	
4	High ripple power TB1 terminals 1 and 2 Notification apps. via control module Notification apps. via control module Releasing devices via control module Other compatible devices (Note 1)	N/A	N/A	N/A	[]	x [] =		[]	x [] =	
		N/A	N/A	N/A	[]	x [] =		[]	x [] =	
		N/A	N/A	N/A	[]	x [] =		[]	x [] =	
		[]	[]	[]	[]	x [] =		[]	x [] =	
5	Non-resettable power TB1 terminals 3 and 4 AFM-16AT/AFM-32A Series ACM-16AT/ACM-32A Series AEM-16AT/AEM-32A Series AFM-16A LCD-80, LCD-80TM (Note 2) ACM-8R (refer to Doc. 15342) LDM (refer to Doc. 15885) UDACT Communicator Other compatible devices (Note 1)	[]	x [0.040]=		[]	x [0.056]=		[]	x [0.040]=	
		[]	x [0.040]=		[]	x [0.056]=		[]	x [0.040]=	
		[]	x [0.002]=		[]	x [0.018]=		[]	x [0.002]=	
		[]	x [0.025]=		[]	x [0.065]=		[]	x [0.025]=	
		[]	x [0.100]=		[]	x [0.100]=		[]	x [0.050]=	
		[]	x [] =		[]	x [] =		[]	x [] =	
		[]	x [] =		[]	x [] =		[]	x [] =	
		[]	x [0.040]=		[]	x [0.100]=		[]	x [0.040]=	
		[]	x [] =		[]	x [] =		[]	x [] =	
6	Resettable Power Four-wire smoke detector Two-wire smoke detector connected to MMX-2/FZM-1 (Note 5) A77-716B Relay Other compatible devices (Note 1)	[]	x [] =		[]	x [] =		[]	x [] =	
		[]	x [] =		[]	x [] =		[]	x [] =	
		[]	x [0.020]=		[]	x [0.020]=		[]	x [0.020]=	
		[]	x [] =		[]	x [] =		[]	x [] =	
7	NAC #1 (Note 1) TB2 terminals 1 and 2 Notification Appliance Releasing Solenoid				[]	x [] =				
					[]	x [] =				
8	NAC #2 (Note 1) TB2 terminals 3 and 4 Notification Appliance Releasing Solenoid				[]	x [] =				
					[]	x [] =				
9	NAC #3 (Notes 1 and 3) TB2 terminals 5 and 6 Notification Appliance Releasing Solenoid				[]	x [] =				
					[]	x [] =				
10	NAC #4 (Notes 1 and 3) TB2 terminals 7 and 8 Notification Appliance Releasing Solenoid				[]	x [] =				
					[]	x [] =				
Subtotals (carry to top line of Part 2)										

**Table 47 System Current Draw Calculations
(Part 1)**

Row	Category	Calculation Column 1 Primary, Non-Fire Alarm Current (amps)			Calculation Column 2 Primary, Fire Alarm Current (amps)			Calculation Column 3 Secondary, Non-Fire Alarm Current (amps)		
		Qty	X [current draw]=	total	Qty	X [current draw]=	total	Qty	X [current draw]=	total
SUBTOTALS FROM PREVIOUS PAGE										
11	SLC Communication Loop									
	B501BH (Horn in base)	[]	x [0.00100]=		[]	x [0.01500]=		[]	x [0.00100]=	
	CMX-2 (relay/NAC)	[]	X 0.00030		[]	X 0.00030		[]	X 0.00030	
	FCM-1 (Supervised NAC)	[]	X 0.00030		[]	X 0.00030		[]	X 0.00030	
	DHX-501	[]	X 0.00020		[]	X 0.00020		[]	X 0.00020	
	DHX-502	[]	X 0.00020		[]	X 0.00020		[]	X 0.00020	
	FZM-1 (IDC) (SLC Current)	[]	X 0.00020		[]	X 0.00020		[]	X 0.00020	
	CPX-551	[]	X 0.00020		[]	X 0.00020		[]	X 0.00020	
	CPX-751	[]	X 0.00020		[]	X 0.00020		[]	X 0.00020	
	FSI-751	[]	X 0.00027		[]	X 0.00027		[]	X 0.00027	
	ISO-X	[]	X 0.00045		[]	X 0.00045		[]	X 0.00045	
	NBG-12LX (with FSM-101)	[]	X 0.00030		[]	X 0.00030		[]	X 0.00030	
	BGX-101L (with MMX-101)	[]	X 0.00030		[]	X 0.00030		[]	X 0.00030	
	FMM-1 (IDC)	[]	X 0.00030		[]	X 0.00030		[]	X 0.00030	
	FMM-101 (IDC)	[]	X 0.00030		[]	X 0.00030		[]	X 0.00030	
	MMX-1 (IDC)	[]	X 0.00030		[]	X 0.00030		[]	X 0.00030	
	MMX-2 (IDC)(SLC current)	[]	X 0.00020		[]	X 0.00020		[]	X 0.00020	
	MMX-101 (IDC)	[]	X 0.00030		[]	X 0.00030		[]	X 0.00030	
	IPX-751	[]	X 0.00035		[]	X 0.00035		[]	X 0.00035	
	FSP-751T	[]	X 0.00027		[]	X 0.00027		[]	X 0.00027	
	FSP-751	[]	X 0.00027		[]	X 0.00027		[]	X 0.00027	
	HPX-751	[]	X 0.00029		[]	X 0.00029		[]	X 0.00029	
	SDX-551	[]	X 0.00020		[]	X 0.00020		[]	X 0.00020	
	SDX-751	[]	X 0.00029		[]	X 0.00029		[]	X 0.00029	
	SDX-551TH	[]	X 0.00020		[]	X 0.00020		[]	X 0.00020	
	SDX-751TH	[]	X 0.00029		[]	X 0.00029		[]	X 0.00029	
	FRM-1	[]	X 0.00020		[]	X 0.00020		[]	X 0.00020	
	FDX-551 and FDX-551R	[]	X 0.00020		[]	X 0.00020		[]	X 0.00020	
	XP5-M	[]	X 0.001651		[]	X 0.003000		[]	X 0.001651	
	XP5-C (Relay)	[]	X 0.000840		[]	X 0.000840		[]	X 0.000840	
	XP5-C (NAC/Telephone)	[]	X 0.001481		[]	X 0.001481		[]	X 0.001481	
	FST-751	[]	X 0.00027		[]	X 0.00027		[]	X 0.00027	
	B524RB	[]	X 0.00050		[]	X 0.00050		[]	X 0.00050	
	B524BI	[]	X 0.00050		[]	X 0.00050		[]	X 0.00050	
12	CHG-120							[]	x [0.060]=	
13	Optional modules									
	RTM-8 (Note 4)	[]	x [0.0010]=		[]	x [0.160]=		[]	x [0.0010]=	
	4XTM	[]	x [0.0110]=		[]	x [0.020]=		[]	x [0.0110]=	
	Municipal Box (Note 5)		N/A			x []=			N/A	
	Reverse Polarity Outputs used	[]	x [0.0050]=		[]	x [0.0050]=		[]	x [0.0050]=	
14	Compatible Devices not listed above (Note 3)	[]	x []=		[]	x []=		[]	x []=	
		[]	x []=		[]	x []=		[]	x []=	
15	Sum each column for totals	Primary non-alarm: (1.0 A max.):			Primary alarm (5.0 A max): Copy to Table 48 "Secondary Alarm Load"			Secondary alarm: Copy to Table 48 "Secondary Standby load"		

**Table 47 System Current Draw Calculations
(Part 2)**

A.5 Calculating the Battery Size

Use Table 48 to calculate the total Standby and Alarm load in ampere hours (AH). This total load determines the battery size (in AH), required to support the control panel under the loss of AC power. Complete Table 48 as follows:

1. Enter the totals from Table 47 Calculation Columns 2 and 3 where shown.
2. Enter the NFPA Standby and Alarm times (refer to "NFPA Battery Requirements" below.)
3. Calculate the ampere hours for Standby and Alarm; then, sum the Standby and Alarm ampere hours.
4. Multiply the sum by the derating factor of 1.2 to get the proper battery size (in ampere hours).
5. Write the ampere-hour requirements on the Protected Premises label located inside

the cabinet door.

Secondary Standby Load (total from Table 47 Calculation Column 3) []	Required Standby Time (24 or 60 hours) x []	=	AH
Primary Alarm Load (total from Table 47 Calculation Column 2) []	Required Alarm Time (For 5 min., enter 0.084, for 10 min., enter 0.168) x []	=	AH
AVPS-24/APS-6R Alarm Load (if using AVPS-24, enter 3.0 A, if using APS-6R enter 6.0 A) []	Required Alarm Time (For 5 min., enter 0.084, for 10 min., enter 0.168) x []	=	AH
Sum of Standby and Alarm Ampere Hours		=	AH
Multiply by the Derating Factor		x 1.2	
Battery Size, Total Ampere Hours Required		=	AH

Table 48 Total Secondary Power Requirements at 24 VDC

A.6 Selecting and Locating Batteries

Select batteries that meet or exceed the total ampere hours calculated (Table 47 on pages 129-130). The control panel can charge batteries in the 7 AH to 18 AH range. Table 49 contains information, such as the battery size and location, for the batteries required to power the control panel if an AC power loss occurs.

Note: 15 AH to 18 AH batteries require the BB-17 or other UL-listed external battery cabinet.

Battery Size	Voltage Rating	Number Required	Part Number	Location
7 AH *	12 volts	two	PS-1270	In control panel
12 AH	12 volts	two	PS-12120	backbox
18 AH	12 volts	two	PS-12180	BB-17 Battery Box
* Maximum alarm load on 7 AH battery is 2.5 Amps				

Table 49 Battery Size and Location

A.7 NFPA Battery Requirements

- NFPA 72 Local and NFPA 72 Remote Station Fire Alarm Systems require 24 hours of standby power followed by 5 minutes in alarm.
- NFPA 72 Central Station, NFPA 72 Auxiliary, and NFPA 72 Remote Station require 60 hours of standby power followed by 5 minutes in alarm. Batteries installed in a system powered by a generator need to provide at least 4 hours of standby power. If sizing battery for 4 hour standby use a derating factor of 1.5
- NFPA 12, 12A, 12B require 24 hours plus 5 minutes activation. The total ampere hours required cannot exceed 18 AH with an internal charger.

Appendix B NFPA Applications

B.1 Section Overview

B.1.1 Specific Requirements

The control panel is designed for use in commercial, industrial, and institutional applications and meets the requirements for service under the National Fire Protection Association (NFPA) Standards outlined in this appendix. The minimum system components required for compliance with the appropriate NFPA standard are listed below.

- AFP-200 control panel containing the main circuit board, cabinet (backbox and door), main supply transformer and power supply.
- Batteries (refer to Appendix A for standby power requirements).
- Initiating devices connected to the control panel's signaling line circuit.
- Notification appliances connected to the control panel's Notification Appliance Circuit or via a control module.

B.1.2 Additional Requirements

Table 50 contains additional equipment that is needed for compliance with the NFPA standards listed below:

NFPA Standard	Application	Refer to
NFPA 72 Central Station Fire Alarm Systems (Protected Premises Unit)	DACT Universal Digital Alarm Communicator/Transmitter or Notifier 911AC DACT for connection to a compatible UL-listed Central Station DACR or Protected Premises Receiving Unit.	"Central Station Fire Alarm Systems (Protected Premises)" on page 133
NFPA 72 Auxiliary Fire Alarm System	RTM-8 Relay Transmitter Module or 4XTM Transmitter Module for connection to a compatible UL-listed Local Energy Municipal Box.	"NFPA 72 Auxiliary Fire Alarm System" on page 135
NFPA 72 Remote Station Fire Alarm System	RTM-8 Relay Transmitter Module or 4XTM Transmitter Module for connection to the Fire•Lite RS-82 Remote Station Receiver. or UDACT Universal Digital Alarm Communicator/Transmitter or Notifier 911AC DACT for connection to a compatible UL-listed remote station DACR.	"Wiring a Remote Station Fire Alarm System" on page 136 "Installing a UDACT" on page 134 and "Installing a Notifier 911AC" on page 133.
NFPA 72 Proprietary Fire Alarm System	NIB-96 Network Interface Board. The NIB-96 must be installed in the receiving system.	"NFPA 72 Proprietary Fire Alarm Systems" on page 138 and the NIB-96 Manual, Document 15666.

Table 50 Additional Equipment for NFPA Applications

B.2 Central Station Fire Alarm Systems (Protected Premises)

B.2.1 Installing a Notifier 911AC

The Notifier 911AC for connection to a Central Station Receiver or Protected Premises Receiving Unit must be installed as shown in Figure 129. For additional information on the 911AC, refer to Document 74-06200-005. The 911AC communicator comes in a separate cabinet. All connections from the 911AC cabinet must be in conduit, less than 20 feet (6.096 m) in length in the same room.

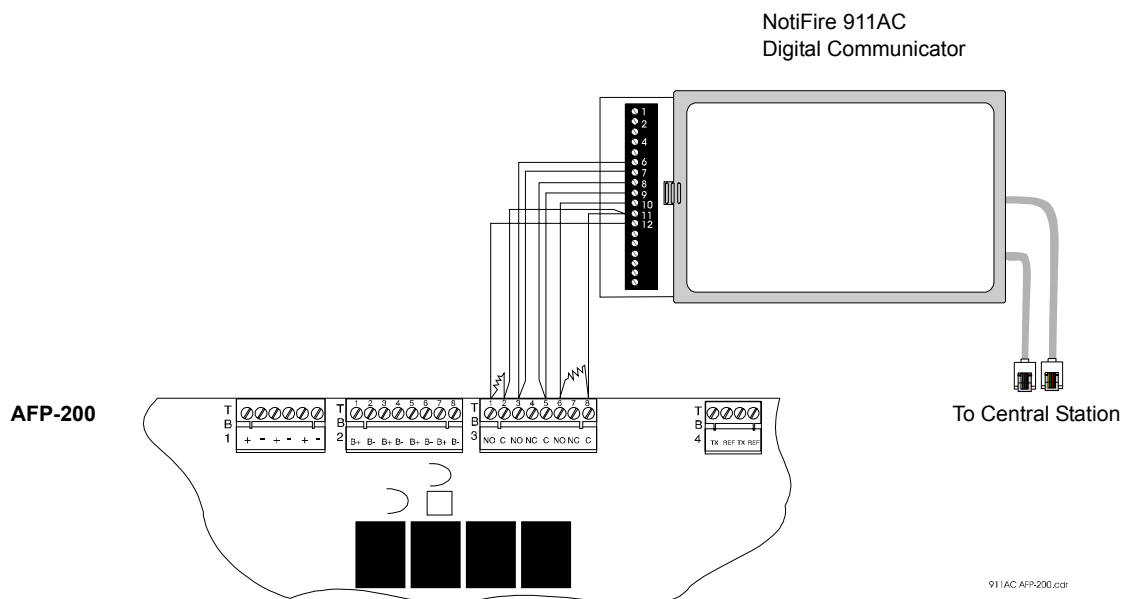

	AFP-200	911AC
Alarm normally open contacts	TB3 Term. 3	6 and 7
	TB3 Term. 5	8 and 9
Trouble normally open contacts	TB3 Term. 6	10
	TB3 Term. 8	11
Supervisory normally open contacts	TB3 Term. 1	12
	TB3 Term. 2	11

Figure 129 911AC Installation

Note:

1. Set SW3 on the control panel circuit board to “TBL LESS AC” (downward) position. This delays the reporting of an AC fail condition for approximately 8 hours to comply with the 1993 UL standards. SW3 is located on the right center of the CPU board (Figure 3 on page 17).
2. All input and output connections are inherently low voltage and power-limited. Use UL-listed, power-limited cable only.

B.2.2 Installing a UDACT

Figure 130 shows typical connections for wiring a UDACT to the control panel. For detailed wiring, configuration, and programming instructions for the UDACT, refer to the UDACT manual. When finished installation, review the checklist below.

Note: This application requires compatible system software—the UDACT must have software PN 73624 or higher and the control panel must have software PN 73609 or higher. Also, add the UDACT current into the control panel power supply calculations (refer to Appendix A “Power Supply Calculations”).

Note: If this is the last or only device on the line, install a 120 ohm end-of-line resistor (PN 71244) on TB1 terminals 3 and 4 as shown.

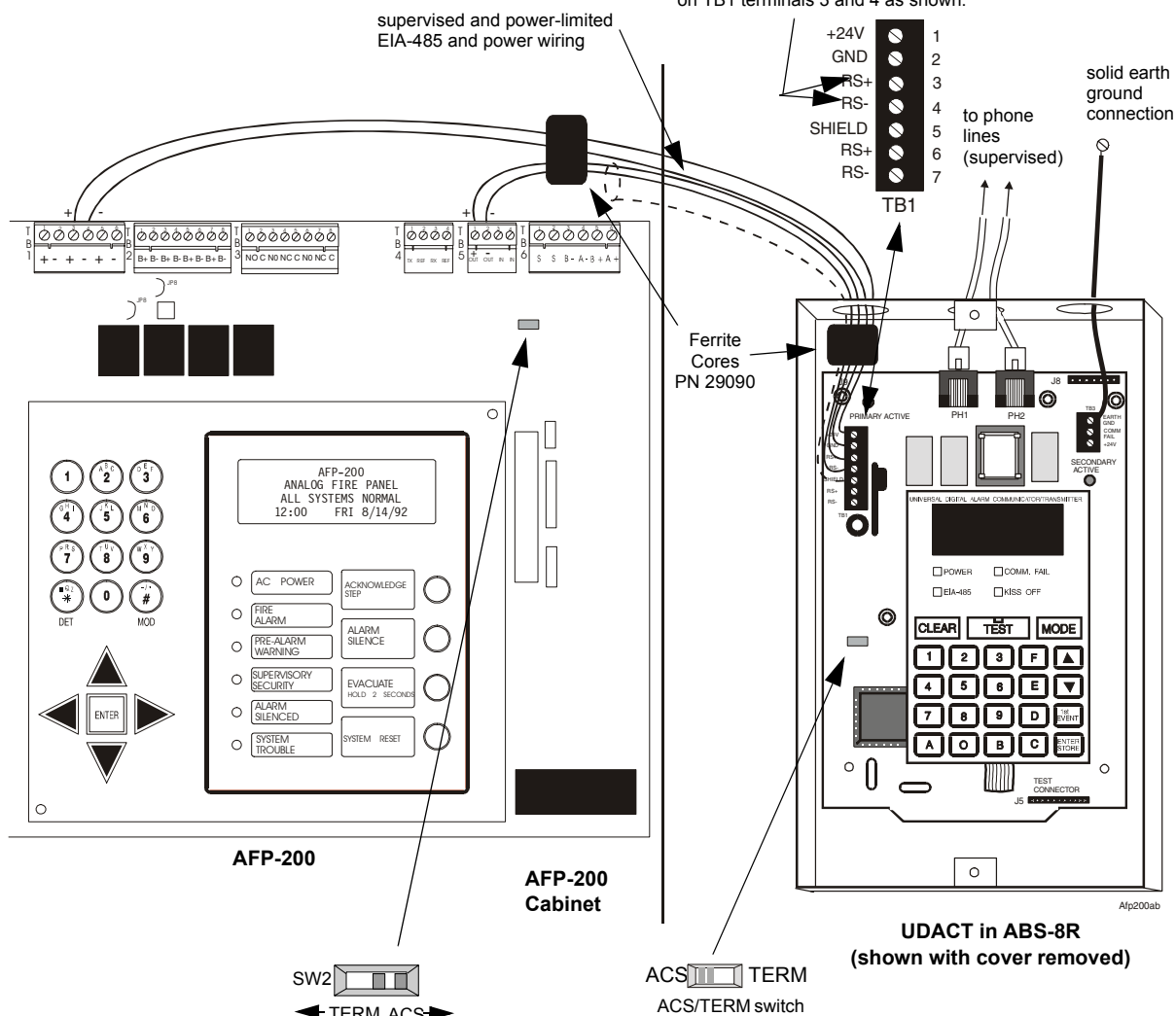

Figure 130 NFPA 72 Central Station Fire Alarm System – UDACT (Protected Premises Unit)

To install a UDACT to the control panel, follow these steps. Check that all items are answered before powering the UDACT or control panel:

1. Is the UDACT connected to non-resettable 24 VDC power on the control panel [TB1, terminal 3 (+) and terminal 4 (-)] with correct polarity (Figure 130)?
2. Is the UDACT connected to the EIA-485 port on the control panel, [TB5, terminal 1 (+) and terminal 2 (-)] with correct polarity (Figure 130)?
3. Is the UDACT ACS/TERM switch set to the ACS (left) position (Figure 130)?
4. Is the UDACT Start Monitor Address set to 1 and is the Stop Monitor Address set

to 2 (refer to the UDACT manual)?

5. Is the ACS/ TERM switch (SW2) on the control panel set to the ACS position?
6. Is the control panel programmed for “ANNUN=UDACT”?
7. Is the control panel configured for proper supervision? Supervise the UDACT via the COMM FAIL output (refer to Monitoring for UDACT Trouble in the UDACT Manual)?
 - For a system without an annunciator – configure the UDACT for *Receive/Transmit*.
 - For a system with an annunciator – configure the UDACT for *Receive Only* and the annunciator for *Receive/Transmit*.

Note: If the annunciator does not require remote control capabilities (Reset, Acknowledge, Silence, etc.), 'COMM FAIL' monitoring is not required if the following conditions are met: the UDACT is configured for “Receive/Transmit” **and** the annunciator is configured for “Receive Only”.

B.3 NFPA 72 Auxiliary Fire Alarm System

Figure 131 and 131 show typical connections (all connections are nonpower-limited and supervised) for wiring the control panel to a municipal box. Maximum loop resistance allowed for wiring from control panel to Municipal Box is 5 ohms. Cut JP5 on control panel circuit board. This application is not suitable for separate transmission of sprinkler supervisory or trouble conditions.

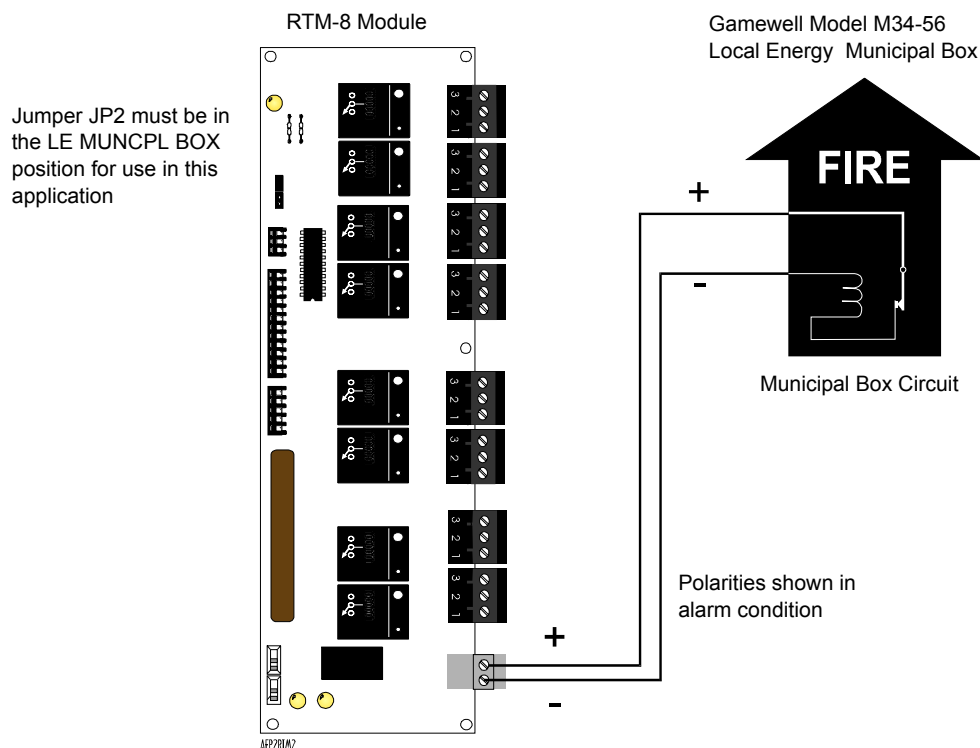

Figure 131 Wiring a Municipal Box Connected to a RTM-8

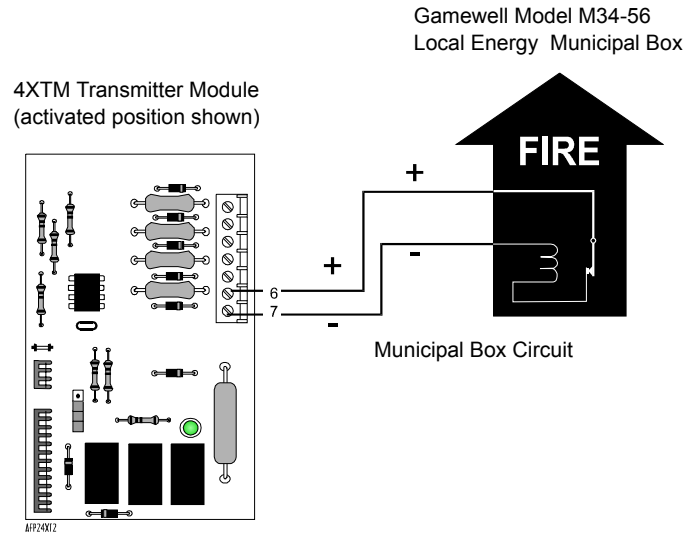

Figure 132 Wiring a Municipal Box Connected to a 4XTM

B.4 Wiring a Remote Station Fire Alarm System

B.4.1 Overview

The NFPA Remote Station Fire Alarm System standard is intended for connection to a polarity reversal circuit of a remote station receiving unit having compatible ratings. All connections are power-limited and supervised with the exception of the reverse polarity loop (loop supervision is the responsibility of the receiver unit). This section shows typical applications for wiring a remote station fire alarm system (a Fire•Lite RS-82 Remote Station Receiver Unit) using a 4XTM module (Figure 133) and using an RTM-8 (Figure 134).

Note: For remote station fire alarm systems, cut Jumper JP5 on the control panel CPU board. For additional information on the RS-82 Remote Station Receiver Unit, refer to the Fire•Lite Alarms, Inc. RS-82 Instruction Manual.

B.4.2 Using a 4XTM Module

Figure 133 shows typical connections for wiring the control panel to remote station fire alarm system using a 4XTM module.

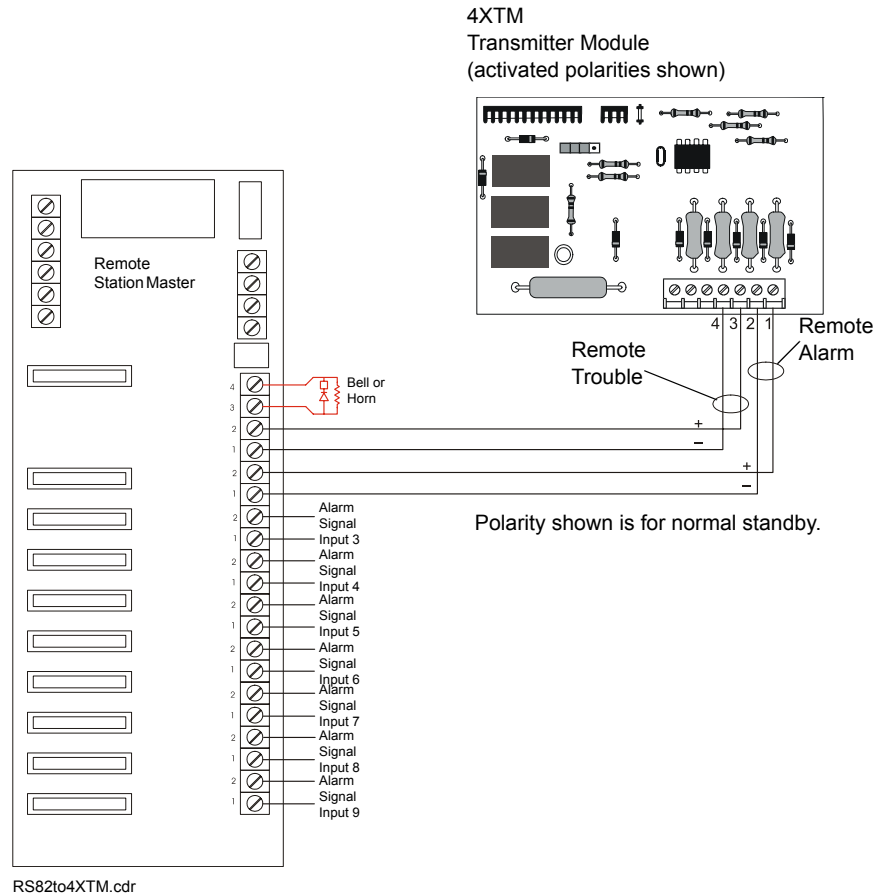

Figure 133 NFPA 72 Remote Station Fire Alarm System

B.4.3 Using an RTM-8 Module

Figure 134 shows typical wiring for an RTM-8 module to a UL-listed Fire•Lite RS-82 Remote Station Receiver. For this application, note the following:

- RTM-8 jumper JP2 must be in position AL/TR REV. POL. for use in alarm and trouble transmission **or** AL ONLY for alarm transmission only.
- For additional information on the RS-82, refer to the Fire•Lite Alarms, Inc. RS-82 Instruction Manual.
- The RTM-8 is not suitable for separate transmission of both alarm and trouble signals to a remote station.
- Cut jumper JP5 on control panel CPU board.

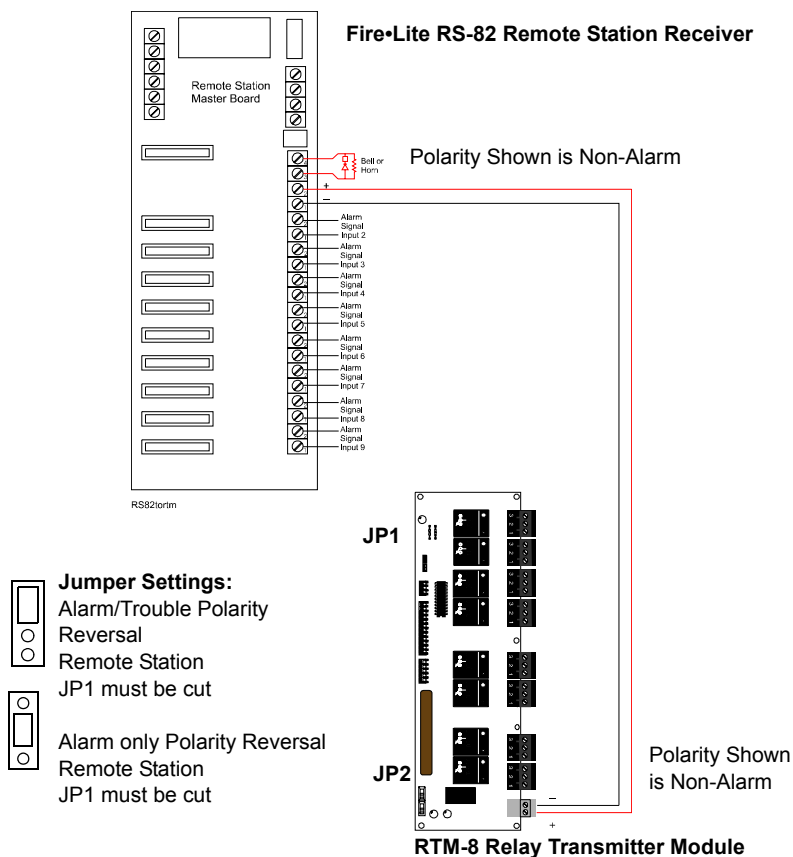

Figure 134 Remote Station Connections Using an RTM-8 Module

B.5 NFPA 72 Proprietary Fire Alarm Systems

Figure 135 shows typical connections between an AFP-200 control panel and receiving unit (NIB-96 in an AM2020) for a proprietary fire alarm application. Table 51 lists wiring connections for the NIB-96, AM2020, and AFP-200.

- Program the AFP-200 for ACS annunciation mode and set switch (SW2) on the CPU board for ACS mode. The ACS interface will automatically transmit General Alarm, General Trouble and General Supervisory signals and will receive Acknowledge, Silence, and Reset commands automatically from the AM2020/AFP1010 control panel. Zone alarm and zone trouble information may be transmitted by programming the AFP-200 points to software zones 1 through 88.
- Up to ten AFP-200 Protected Premises Units may be monitored by one AM2020/AFP1010 Receiving Unit using ten SLC loops and ten NIB-96 modules.
- Disable the ground fault circuit on the AFP-200 by cutting jumper JP9 because the

- AM2020/AFP1010 performs ground fault protection for the control panel circuits.
- If connecting an RPT-485W isolating repeater module between the AM2020/AFP1010 and the control panel, a common connection between the two panels is not needed. However—a system common connection must be made from the AFP-200 to RPT-485W, **and** the AFP-200 ground fault jumper JP9 should not be cut.
- For Receiving Unit installation and programming, refer to the AM2020/AFP1010 manual and the NIB-96 manual.

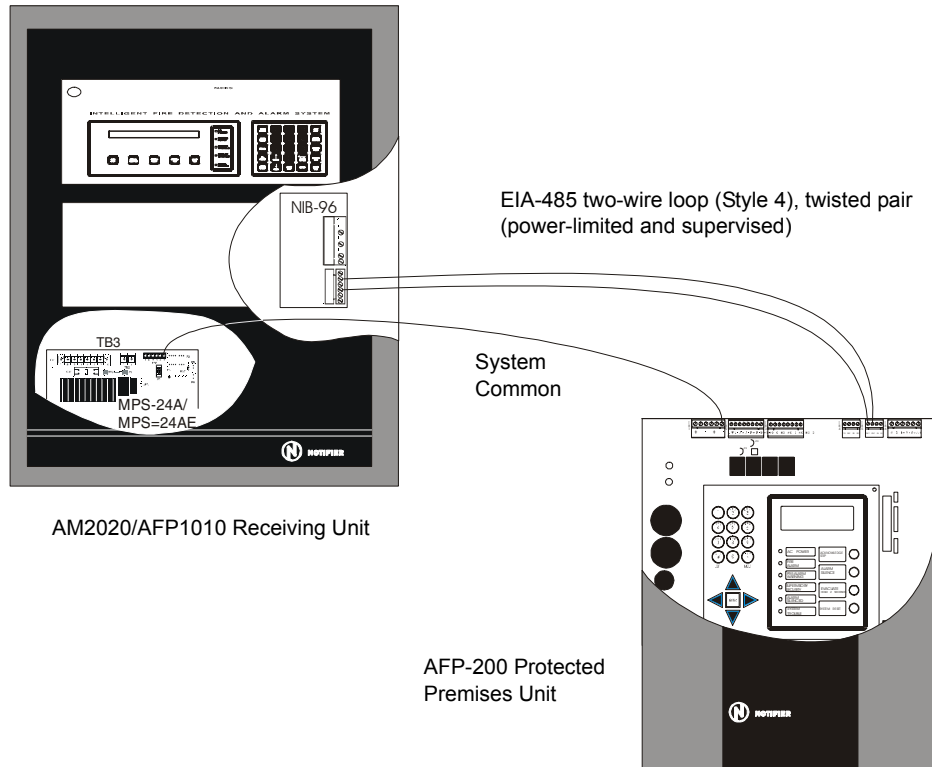

Figure 135 NFPA 72 Proprietary Fire Alarm Systems

	NIB-96	AFP-200	MPS-24A
EIA-485 (+)	P4 Term. 5	TB5 Term. 1	
EIA-485 (-)	P4 Term. 3	TB5 Term. 2	
System Common		TB1 Term. 6	TB3 Term. 6

Table 51 Proprietary Fire Alarm Systems Wiring Connections

Appendix C Annunciators

C.1 LCD-80 Display

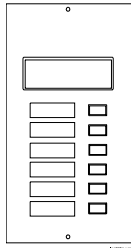

The LCD-80 alphanumeric display module is an AFP-200 ancillary device that provides two modes of operation: Terminal Mode, where the LCD-80 acts as a display repeater; and ACS Mode, where the LCD-80 acts as an alphanumeric annunciator. To select the operation mode, use switch SW2 on the CPU (Figure 3 on page 17). The LCD-80 features the following:

- 80-character LCD display that backlights under normal and alarm conditions
- Control switches for Acknowledge, Alarm Silence, and System Reset, all made operational by an optional AKS-1 switch
- Time and date display field
- Annunciator backbox ABF-1 package with optional AKS-1 key switch and phone jack options
- Remote operation (mounts up to 6,000 feet (1828.8 m) from the control panel)
- Local panel sounder with alarm/trouble resound

C.1.1 ACS Mode

ACS Mode, which requires programming the LCD-80, provides a remote or local digital display and a printer interface for the control panel and provides the following features:

- | | |
|---|--|
| <ul style="list-style-type: none"> • General status banner • 40 character custom label • Step Display and Time/Date/Set switches • Custom “normal” message • Alarm and trouble count • First alarm/last alarm/alarm count (European option) | <ul style="list-style-type: none"> • Field-programmable messages (available in English and all foreign language versions) • Field programmable, nonvolatile memory in two options (128 points, 40-character labels or 256 points, 20-character labels) • Internal nonvolatile clock |
|---|--|

C.1.2 Terminal Mode

Terminal Mode, which does not require any programming, offers the following features: Device type identifiers from control panel; device and zone custom alphanumeric labels from control panel, and time/date and device address from control panel.

C.2 Terminal Mode (LCD-80) Annunciation Interface (TB5 on CPU)

In Terminal mode, the control panel annunciates all point information to remote LCD-80 displays. Each LCD-80 mirrors the control panel LCD display and includes Acknowledge, Silence, and Reset switches. An LCD-80 will display all 198 intelligent points without being programmed. Switch SW2 on the CPU board must be set for TERM and the control panel must be programmed for Terminal mode.

C.3 ACS Annunciation Interface (TB5 on CPU)

In ACS mode, the control panel annunciates its 99 software zones. The use of software zones lets you map any number of modules or detectors to a single LED. The ACS connection uses a standard EIA-485 interface, capable of two-way, high speed communications with multiple annunciators located up to 6,000 ft. from the control panel.

Canadian Requirement: The ACM Series annunciator modules must be used to annunciate the fire alarm input points/zones only. For Canadian applications, the following LED colors must be employed:

- Red must be used to indicate active alarm inputs
- Yellow must be used to indicate supervisory, burglary or trouble signals
- Green must be used to indicate the presence of power or an activated output

C.3.1 Supported Modules

When programmed for ACS mode, the control panel will support the following ACS-compatible modules:

- Point annunciators

ACM-16AT, AEM-16AT	ACM-32A, AEM-32A
AFM-16A, AFM-32A, AFM-16AT	LDM-32, LDM-E32, LDM-R32

- **ACM-8R** – This module may be used to increase the relay capacity of the control panel by providing mappable dry contact relays. The control panel can support 99 detectors, 99 modules, four Notification Appliance Circuits, eight internal relays, and 99 external relays, for a total of over 300 points. The ACM-8R may be powered by the regulated/high-ripple notification appliance power from the control panel. For detailed information, refer to ACM-8R manual.

Note: Similar point capacity extension is possible using the LDM-R32, but the LDM-32 series must use filtered, regulated power and is therefore more limited than the ACM-8R.

- **LCD-80** – The LCD-80 must be set to ACS mode (refer to the LCD-80 manual).

C.4 Annunciator Capacity

ACS annunciation displays the 99 software zones of the control panel plus 8 system points, for a total of 107. Information is transmitted using annunciator addresses 1 and 2. The EIA-485 interface will allow up to 32 annunciators (all but two must be in receive-only mode), over distances of up to 6,000 feet (1828.8 m) subject to system power limitations.

C.4.1 Data Formats for Annunciator Address 1

Table 52 contains the data formats available at annunciator address 1. Note the following:

1. The use of a UDACT Universal Digital Alarm Communicator/Transmitter and an ACM, AFM or LDM Series Annunciator on the same control panel alters the assignments of the yellow LEDs on ACS Points 3, 4, 5, 6, 7 and 8.
2. Assignments with the UDACT are Point 3=Program Mode, Point 4=Supervisory, Point 5=Bell Trouble, Point 6=Prealarm/Maintenance Alert, Point 7=Low Battery and Point 8=AC Fail.

C.4.2 Data Formats at Annunciator Address 2

Table 53 contains the data formats for annunciator address 2. Note the following:

1. The National Standard of Canada (CAN/ULC-5527) requires a dedicated display to use yellow visual indicators to show the status of supervisory inputs. Notifier annunciators intended for Canadian Supervisory Service are: ACM-16ATCS4, ACM-16ATCS, ACM-16ATY, ACM-32ACS8, ACM-32ACS, and ACM-32AY.
2. On address 2, LED number = point number – 56

ACS Point no.	I/O	Red LED	Yellow LED	Yellow LED with UDACT	Switch	Comments
1	Input	System Alarm	System Trouble ¹	System Trouble ¹	Acknowledge	
2	Output	Not used	Signals Silenced	Signals Silenced	Signal Silence	
3	Output	Not used	Not used	Program Mode	System Reset	See Note 1
4	Output	Not used	Not used	Supervisory	Drill	
5	Input	Not used	Supervisory	Bell Trouble	Not used	Panel Supervisory LED on
6	Input	Not used	Pre-Alarm	Pre-Alarm/Maint. Alert	Not used	Trouble
7	Input	Not used	Panel trouble	Low Battery	Not used	Trouble
8	Input	Not used	AC Fail	AC Fail	Not used	Battery/Earth Trouble
9	Input	Z1 Active	Z1 Trouble		Not used	
10	Input	Z2 Active	Z2 Trouble		Not used	
11	Input	Z3 Active	Z3 Trouble		Not used	
12	Input	Z4 Active	Z4 Trouble		Not used	
13	Input	Z5 Active	Z5 Trouble		Not used	
14	Input	Z6 Active	Z6 Trouble		Not used	
15	Input	Z7 Active	Z7 Trouble		Not used	
16	Input	Z8 Active	Z8 Trouble		Not used	
17	Input	Z9 Active	Z9 Trouble		Not used	
18	Input	Z10 Active	Z10 Trouble		Not used	
19	Input	Z11 Active	Z11 Trouble		Not used	
20	Input	Z12 Active	Z12 Trouble		Not used	
21	Input	Z13 Active	Z13 Trouble		Not used	
22	Input	Z14 Active	Z14 Trouble		Not used	
23	Input	Z15 Active	Z15 Trouble		Not used	
24	Input	Z16 Active	Z16 Trouble		Not used	
25	Input	Z17 Active	Z17 Trouble		Not used	
26	Input	Z18 Active	Z18 Trouble		Not used	
27	Input	Z19 Active	Z19 Trouble		Not used	
28	Input	Z20 Active	Z20 Trouble		Not used	
29	Input	Z21 Active	Z21 Trouble		Not used	
30	Input	Z22 Active	Z22 Trouble		Not used	
31	Input	Z23 Active	Z23 Trouble		Not used	
32	Input	Z24 Active	Z24 Trouble		Not used	
33	Input	Z25 Active	Z25 Trouble		Not used	
34	Input	Z26 Active	Z26 Trouble		Not used	
35	Input	Z27 Active	Z27 Trouble		Not used	
36	Input	Z28 Active	Z28 Trouble		Not used	
37	Input	Z29 Active	Z29 Trouble		Not used	
38	Input	Z30 Active	Z30 Trouble		Not used	
39	Input	Z31 Active	Z31 Trouble		Not used	
40	Input	Z32 Active	Z32 Trouble		Not used	
41	Input	Z33 Active	Z33 Trouble		Not used	
42	Input	Z34 Active	Z34 Trouble		Not used	
43	Input	Z35 Active	Z35 Trouble		Not used	
44	Input	Z36 Active	Z36 Trouble		Not used	
45	Input	Z37 Active	Z37 Trouble		Not used	
46	Input	Z38 Active	Z38 Trouble		Not used	
47	Input	Z39 Active	Z39 Trouble		Not used	
48	Input	Z40 Active	Z40 Trouble		Not used	
49	Input	Z41 Active	Z41 Trouble		Not used	
50	Input	Z42 Active	Z42 Trouble		Not used	
51	Input	Z43 Active	Z43 Trouble		Not used	
52	Input	Z44 Active	Z44 Trouble		Not used	
53	Input	Z45 Active	Z45 Trouble		Not used	
54	Input	Z46 Active	Z46 Trouble		Not used	
55	Input	Z47 Active	Z47 Trouble		Not used	
56	Input	Z48 Active	Z48 Trouble		Not used	
57	Input	Z49 Active	Z49 Trouble		Not used	
58	Input	Z50 Active	Z50 Trouble		Not used	
59	Input	Z51 Active	Z51 Trouble		Not used	
60	Input	Z52 Active	Z52 Trouble		Not used	
61	Input	Z53 Active	Z53 Trouble		Not used	
62	Input	Z54 Active	Z54 Trouble		Not used	
63	Input	Z55 Active	Z55 Trouble		Not used	
64	Input	Z56 Active	Z56 Trouble		Not used	

Note: 1 System Trouble excludes AC Power Fail.

Table 52 Data Formats at Annunciator Address 1

ACS Point #	I/O	Red LED	Yellow LED	Switch	Comments
1	Input	Z57 Active	Z57 Trouble	Not used	
2	Input	Z58 Active	Z58 Trouble	Not used	
3	Input	Z59 Active	Z59 Trouble	Not used	
4	Input	Z60 Active	Z60 Trouble	Not used	
5	Input	Z61 Active	Z61 Trouble	Not used	
6	Input	Z62 Active	Z62 Trouble	Not used	
7	Input	Z63 Active	Z63 Trouble	Not used	
8	Input	Z64 Active	Z64 Trouble	Not used	
9	Input	Z65 Active	Z65 Trouble	Not used	
10	Input	Z66 Active	Z66 Trouble	Not used	
11	Input	Z67 Active	Z67 Trouble	Not used	
12	Input	Z68 Active	Z68 Trouble	Not used	
13	Input	Z69 Active	Z69 Trouble	Not used	
14	Input	Z70 Active	Z70 Trouble	Not used	
15	Input	Z71 Active	Z71 Trouble	Not used	
16	Input	Z72 Active	Z72 Trouble	Not used	
17	Input	Z73 Active	Z73 Trouble	Not used	
18	Input	Z74 Active	Z74 Trouble	Not used	
19	Input	Z75 Active	Z75 Trouble	Not used	
20	Input	Z76 Active	Z76 Trouble	Not used	
21	Input	Z77 Active	Z77 Trouble	Not used	
22	Input	Z78 Active	Z78 Trouble	Not used	
23	Input	Z79 Active	Z79 Trouble	Not used	
24	Input	Z80 Active	Z80 Trouble	Not used	
25	Input	Z81 Active	Z81 Trouble	Not used	
26	Input	Z82 Active	Z82 Trouble	Not used	
27	Input	Z83 Active	Z83 Trouble	Not used	
28	Input	Z84 Active	Z84 Trouble	Not used	
29	Input	Z85 Active	Z85 Trouble	Not used	
30	Input	Z86 Active	Z86 Trouble	Not used	
31	Input	Z87 Active	Z87 Trouble	Not used	
32	Input	Z88 Active	Z88 Trouble	Not used	
33	Input	Z89 Active	Z89 Trouble	Not used	
34	Input	Z90 Active	Z90 Trouble	Not used	Presignal Time Run Time
35	Input	Z91 Active	Z91 Trouble	Not used	Started/Release Time
36	Input	Z92 Active	Z92 Trouble	Not used	Started/Release Time
37	Input	Z93 Active	Z93 Trouble	Not used	Started/Release Time
38	Input	Z94 Active	Z94 Trouble	Not used	Started/Release Time
39	Input	Z95 Active	Z95 Trouble	Not used	Time Control Active
40	Input	Z96 Active	Z96 Trouble	Not used	Time Control Active
41	Input	Z97 Active	Z97 Trouble	Not used	Holiday Active
42	Input	Z98 Active	Z98 Trouble	Not used	Tornado Active
43	Input	Z99 Active	Z99 Trouble	Not used	Pre-Alarm Active
44	Input	Not used	Not used	Not used	
45	Input	Not used	Not used	Not used	
46	Input	Not used	Not used	Not used	
47	Input	Not used	Not used	Not used	
48	Input	Not used	Not used	Not used	
49	Input	Not used	Not used	Not used	
50	Input	Not used	Not used	Not used	
51	Input	Not used	Not used	Not used	
52	Input	Not used	Not used	Not used	
53	Input	Not used	Not used	Not used	
54	Input	Not used	Not used	Not used	
55	Input	Not used	Not used	Not used	
56	Input	Not used	Not used	Not used	
57	Input	Not used	Not used	Not used	
58	Input	Not used	Not used	Not used	
59	Input	Not used	Not used	Not used	
60	Input	Not used	Not used	Not used	
61	Input	Not used	Not used	Not used	
62	Input	Not used	Not used	Not used	
63	Input	Not used	Not used	Not used	
64	Input	Not used	Not used	Not used	

Table 53 Data Formats at Annunciator Address 2

C.5 Terminal Mode EIA-485 Connections (TB5)

Refer to the LCD-80 Manual for additional information.

This section shows how to install LCD-80s set for Terminal Mode to the control panel, subject to the following:

- **Maximum number of LCD-80s allowed** – A maximum of four LCD-80s may be connected when powered by the control panel. If, however, the LCD-80s are powered by a separate UL-listed power supply, up to 32 may be connected.
- **Maximum distance** – There is a 6,000 foot (1828.8 m) maximum distance (16 AWG) between the control panel and the first or last LCD-80 and between each LCD-80.
- **Cable** – Use overall foil/braided-shield twisted-pair cable suitable for EIA-485 applications.
- **Circuit rating** – The EIA-485 circuit is rated 5.5 VDC max., 60 mA max. For non-English language systems, LCD-80 standby current is the same as the alarm current (100 mA).

Connect the EIA-485 circuit as follows:

1. Connect each LCD-80 to 24 VDC operating power (power-limited and supervised) to the AFP-200 as shown in Figure 139 on page 146.
2. Set SW2 on the control panel to the TERM position (left position).
3. Set SW4 and SW5 on the LCD-80 to the TERM position: SW1-7 ON.
4. Install R-120 resistors across the in and out terminals of each LCD-80 as shown in Figure 136.

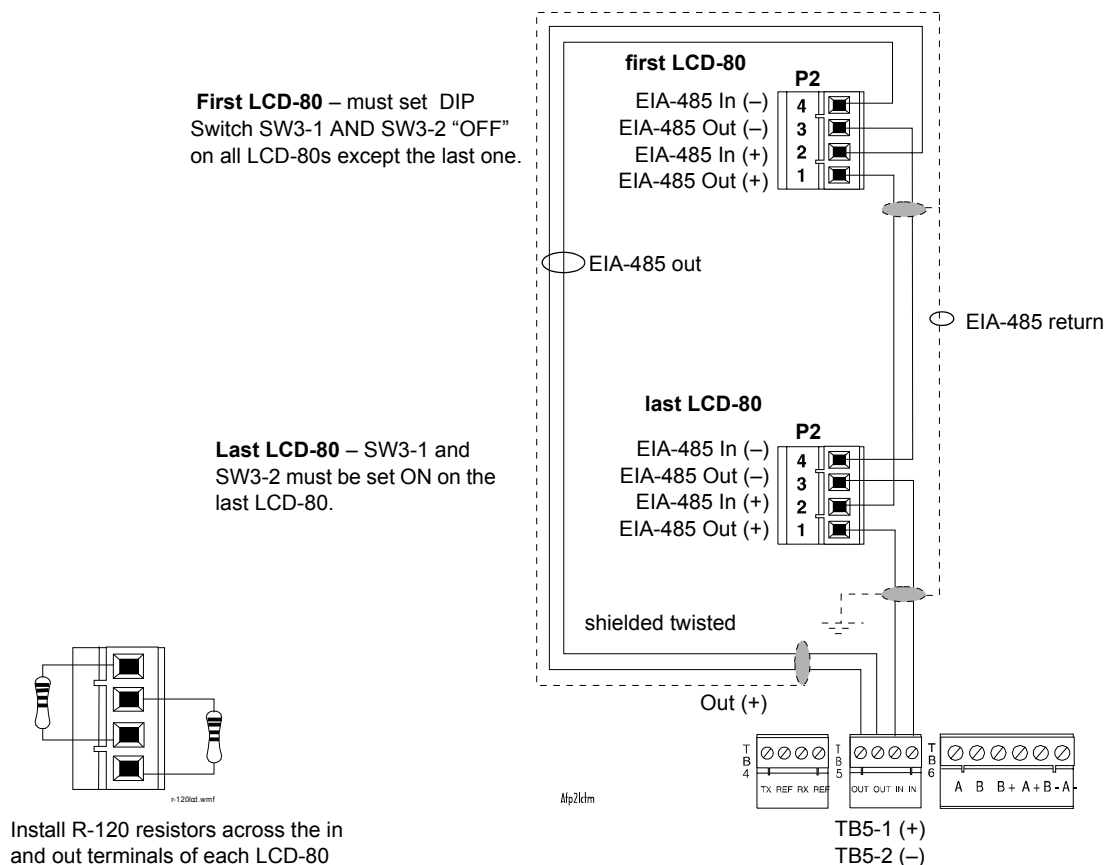

C.6 LCD-80 ACS Mode EIA-485 Connections

Refer to the LCD-80 Manual for additional information.

This section shows how to install LCD-80s set to ACS Mode to the control panel, subject to the following:

- **Maximum number of LCD-80s allowed** – A maximum of four LCD-80s may be connected when powered by the control panel. If, however, the LCD-80s are powered by a separate UL-listed power supply, up to 32 may be connected.
- **Maximum distance** – There is a 6,000 foot (1828.8 m) maximum distance (16 AWG) between the control panel and the first or last LCD-80 and between each LCD-80.
- **Cable** – Use overall foil/braided-shield twisted pair cable with a characteristic impedance of approximately 120 ohms.
- **Circuit rating** – The EIA-485 circuit is rated 5.5 VDC max., 60 mA max.
- **Connections** – All connections are power-limited and supervised.

This section shows how to install LCD-80s set to ACS Mode to the control panel, subject to the following:

Connect the EIA-485 circuit as follows:

1. Connect each LCD-80 to 24 VDC operating power (power-limited and supervised) to the AFP-200 as shown in Figure 139 on page 146.
2. Set SW2 on the control panel to the “ACS” position (right position).
3. Set the LCD-80 start address to 01.
4. On the LCD-80, set switch SW2 to “1”, and set SW3-1 and SW3-2 to “OFF”.
5. Set the LCD-80 to a size of 128 points.
6. To use a 40-character display; set SW5 OFF and SW6 ON. To use a 20-character display; set SW5 ON and SW6 OFF.

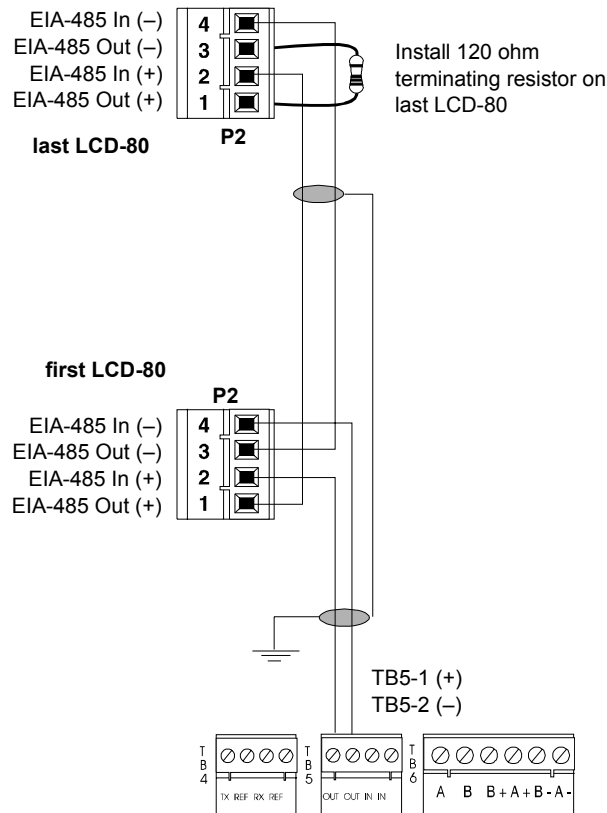

Figure 137 LCD-80 ACS Mode EIA-485 Connection

C.7 Power Connections for LCD and ACS Series Annunciators

This section shows how to wire power connections for ACS and LCD series annunciators. Note the following when making power connections:

- All connections are power-limited.
- The power run to the LCD-80 or ACS annunciator does not require a Power Supervision Relay because the loss of power is inherently supervised through communication loss.
- The maximum LCD-80 current draw from power supply is 500 mA.

Figure 139 shows typical power wiring for ACS and LDM series annunciators:

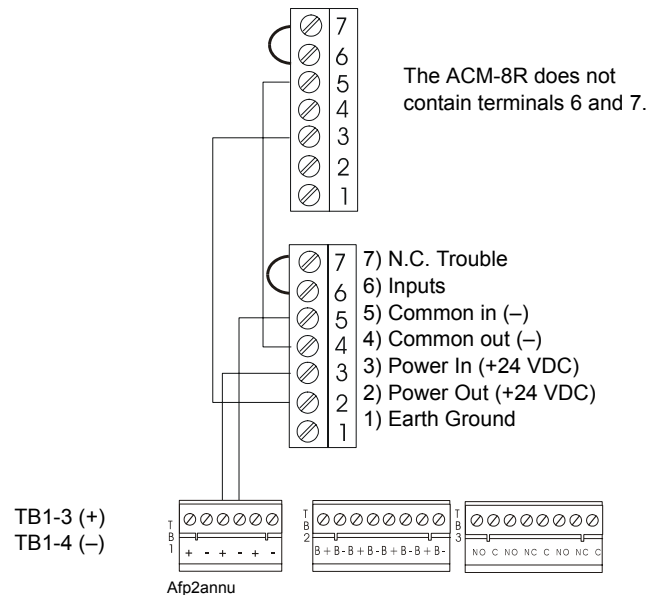

Figure 138 Power Connections for LDM and ACS Series Annunciators

Figure 140 shows typical power wiring for LCD-80 series annunciators:

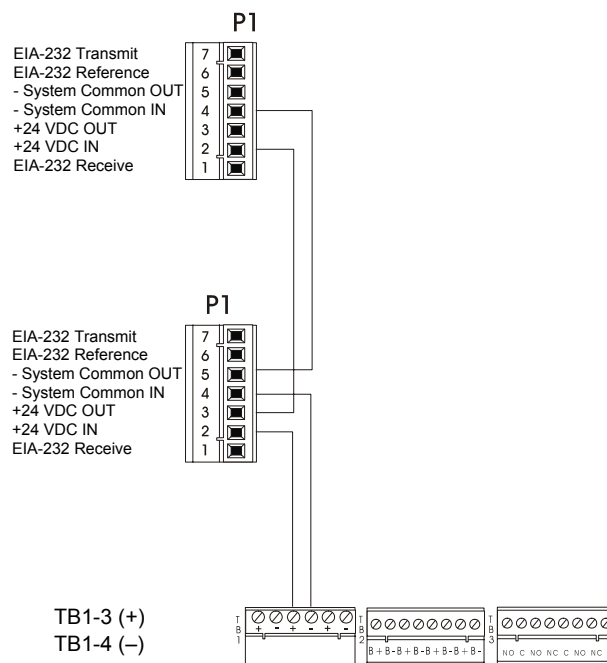

Figure 139 Power Connections for LCD-80 Series Annunciators

C.8 ACS and LDM Series EIA-485 Connections

Refer to the LDM and ACS manuals for additional information.

This section shows how to connect ACS and LDM series annunciators to the control panel, subject to the following:

- **Maximum number allowed** – A maximum of 10 point annunciators (such as ACM, LDM, AFM) can be connected to this circuit when powered by the control panel.
- **Maximum distance** – There is a 6,000 foot (1828.8 m) maximum distance (16 AWG) between the control panel and the furthest annunciator.
- **Cable** – Use twisted pair cable with a characteristic impedance of approximately 120 ohms.
- **Circuit rating** – The EIA-485 circuit is rated 5.5 VDC max., 60 mA max.
- **Connections** – All connections are power-limited and supervised.

Connect the EIA-485 circuit as follows:

1. Connect each annunciator to 24 VDC operating power (power-limited and supervised) to the AFP-200 as shown in Figure 139 on page 146.
2. Set SW2 on the control panel to the “ACS” position (right position).

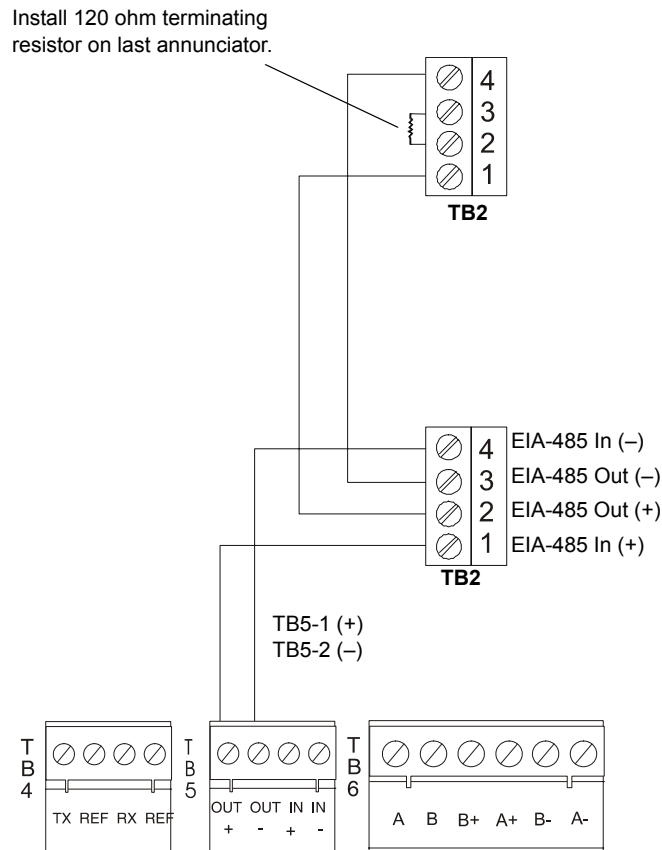

Figure 140 ACS and LDM Series EIA-485 Connection

Appendix D Releasing Applications

D.1 NFPA Standards

The control panel can be used for agent release or preaction/deluge control applications. When used with compatible, UL-listed actuating and initiating devices, the control panel meets the requirements of the NFPA standards listed in Table 54:



WARNING: When used for CO₂ releasing applications, observe proper precautions as stated in NFPA12. Do not enter the protected space unless physical lockout and other safety procedures are fully completed. Do not use software disable functions in the panel as lockout.



WARNING: Use only SLC control module outputs for agent releasing applications.

NFPA 12	CO ₂ Extinguishing Systems (high pressure only)
NFPA 12A	Halon 1301 Extinguishing Systems
NFPA 12B	Halon 1211 Extinguishing Systems
NFPA 13	Sprinkler Systems
NFPA 15	Water Spray Systems
NFPA 16	Foam-water Deluge and Foam-water Spray Systems
NFPA 17	Dry Chemical Extinguishing systems
NFPA 17A	Wet Chemical Extinguishing systems
NFPA 2001	Clean Agent Extinguishing systems

Table 54 NFPA Standards for Releasing Applications

D.2 Programming Releasing Zones

The control panel includes four software releasing zones (zones 91, 92, 93 and 94) used to control releasing functions. Each releasing zone operates independently, and is fully programmable. Program releasing zones from the Releasing Zone screen (Figure 141). To display the Release Control screen, select 91-94 from the Special Zone Program Change screen.

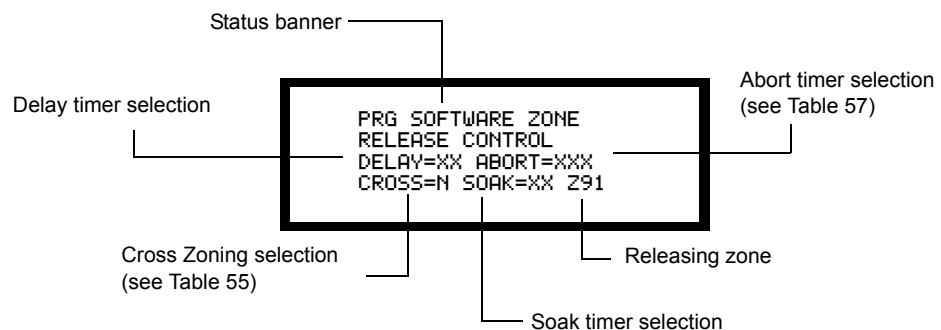

Figure 141 Release Control Screen

D.2.1 Releasing Zone Functions

Releasing zone functions include the following:

- Delay Timer
- Abort Timer
- Cross Zone
- Soak Timer

D.2.2 Delay Timer

A Delay Timer lets you program a delay time (0-60 seconds; 00=no delay timer) for output devices mapped to a releasing zone. In Figure 142 for example, SLC control modules M01 and M02 are mapped to releasing zone Z91. If Z91 is programmed for a delay time of 30 seconds, M01 and M02 do not activate until 30 seconds after Z91 activates.

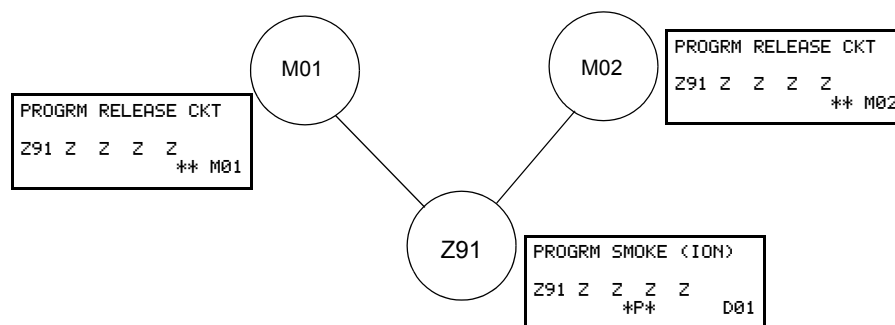

Figure 142 Mapped Devices to a Releasing Zone

When using a Delay Timer, note the following:

- If cross-zoning is selected for the releasing zone, the delay timer starts when two or more devices are in alarm (for more information, refer to “Cross Zoning”).
- If abort or manual release type monitor modules are mapped to this zone they affect the timer operation as described in “Abort Timer”.

D.2.3 Cross Zoning

Cross Zoning lets you program the control panel to activate a releasing zone and any output mapped to the releasing zone. (If not using Cross Zoning, set CROSS= to N.) Table 55 summarizes the types of cross zoning and the conditions for activating a releasing zone and Table 56 shows an example of a cross zoning application.

Type	Activates when...
Y	Two or more detectors are alarmed that are mapped to one of the four releasing zones (Z91-Z94).
Z	Two or more detectors are alarmed that are mapped to two different software zones and mapped to one of the four releasing zones (Z91-Z94).
H	At least one smoke detector mapped to one of the four releasing zones (Z91-Z94) is alarmed and at least one heat detector mapped to one of the four releasing zones (Z91-Z94) is alarmed.

Table 55 Cross Zoning Types

Note: Only the first non-special zone listed in the zone map is used to determine Cross=Z.

Table 56 contains examples of devices mapped to releasing zones:

Device Address	Device Type	Zone Mapping
D01	Detector Smoke	Z91 Z02
D02	Detector Smoke	Z91 Z02
D03	Detector Smoke	Z91 Z03
D04	Detector Heat	Z91 Z03
M01	SLC Control Module connected to a releasing circuit (Rel Ckt)	Z91

Table 56 Example: Devices Mapped to Releasing Zones

The following explanations apply to the examples listed in Table 56:

- **Cross=N** – An alarm from any detector activates the releasing module circuit.
- **Cross=Y** – An alarm from any two detectors in the system activates the releasing module circuit.
- **Cross=Z** – Release requires the activation of two detectors mapped to different zones: D01 and D02 cannot activate the releasing module circuit because both detectors are mapped to the same zones; D01 and D03 can activate the releasing module circuit because they are mapped to different zones.
- **Cross=H** – Release requires activation of heat detector D04 and one smoke detector (D01, D02, or D03).

D.2.4 Soak Timer (NFPA 16 Applications Only)

The Soak Timer specifies the length of time (10 to 15 minutes) to dump release agents when a releasing zone activates. When the Soak Timer elapses, the control panel automatically shuts off the releasing solenoids for the active releasing zone. To program a Soak Timer, follow these instructions:

1. Select Soak on the Release Control Screen, move the cursor to the Soak value as shown in Figure 143:

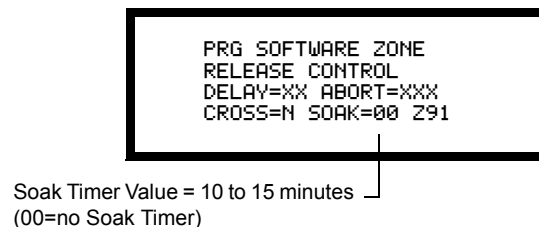

Figure 143 Soak Timer Selection

2. Enter a value for the Soak Timer: 00=no Soak Timer; or 10-15 minutes to select the amount of time for the Soak Timer.

D.2.5 Abort Timer

Description:

Abort is the type of abort algorithm used by the releasing zone. There are four types of Abort Timers: ULI, IRI, NYC or AHJ. Table 57 contains descriptions of each Abort Timer:

Type of Abort Timer	Description
ULI	This is a standard UL-type delay timer which continues to count down upon ABORT, and stops and holds at 10 seconds until release of the Abort switch. Upon release of the Abort switch, the delay timer resumes the countdown at 10 seconds.
IRI	This is an IRI-type delay timer that provides all functions of a ULI timer — except the Abort switch only functions if you press and hold the Abort switch before the second zone goes into alarm.
NYC	This is a NYC-type delay timer. Pressing ABORT, once an alarm exists, changes the timer value to the time selected plus 90 seconds. The timer will not start as long as the abort switch is held.
AHJ	This is a Local Jurisdiction delay timer that works as follows: Once the timer starts, pressing Abort restores the timer to its full time. The timer will not start while the Abort switch is held. Releasing the Abort switch continues the countdown, while pressing the Abort switch again restores the timer to its full value.
Notes:	
<ul style="list-style-type: none"> • An Abort timer does not operate when timer is set for “NO DELAY”. • ULI and IRI are the only abort timers that comply with UL Standard 864. 	

Table 57 Types of Abort Timers

D.2.6 Special Module Type Codes

You can program special releasing functions using four module type codes: ABORT SWITCH, MAN. RELEASE, REL CKT ULC, and RELEASE CKT. Special releasing device type codes are listed below.

D.2.7 Abort Switch

Description: *Abort Switch* is a type code assigned to a monitor module which performs the abort functions described in Table 57.

Installation: The monitor module connects to a UL-listed abort station, such as the full-time, permanent. All wiring is fully supervised, following the wiring instructions for the monitor modules (refer to Section 2 “Installation”). You can also install multiple Abort Switch modules, which provide a logical “or” function, similar to multiple conventional abort switches on a single conventional zone.

D.2.8 Man. Release

Description: *Man Release* is a type code assigned to a monitor module which performs a manual release function.

Installation: The monitor module connects to a UL-listed manual station, such as the NBG-12LRA. A monitor module programmed for *Man. Release* overrides all *Abort Switch* modules that are active and programmed to the same releasing zone.

All wiring is fully supervised, when connected according to the wiring instructions for the monitor modules in Section 2 “Installation”. You can also install multiple *Man. Release* modules, which provide a logical “or” function, similar to multiple conventional abort switches on a single conventional zone.

D.2.9 Rel Ckt ULC

Description: *Rel Ckt ULC* is a type code assigned to an SLC control module. A device programmed with this type code activates a releasing solenoid or other releasing device as follows:

- when an initiating device programmed to the same zone activates (two devices if cross-zoning selected); **and**
- when the delay timer (if used) expires; **and**
- when no Abort Switch (if used) is active.

Installation: All wiring to the releasing device, and the releasing device itself, is fully supervised and suitable for use with limited energy cable. You can program multiple *Release CKT* type codes to the same releasing zone so all devices activate when the same releasing zone becomes active.

D.2.10 Release Ckt

Description: *Release Ckt* is a type code that operates similar to *Rel Ckt ULC*—except a *Release Ckt* device is only supervised for open circuits and ground faults. A device programmed for Release Ckt is not supervised for short circuits.

Installation: All wiring to the releasing device, and the releasing device itself, is fully supervised. You can program multiple *Release CKT* type codes to the same releasing zone so all devices activate when the same releasing zone becomes active.

Restrictions: Do not use this type code with the following:

- Applications requiring ULC listing or with limited energy cable.
- REL-47K (control module) with a Release Ckt type code.

D.2.11 Initiating Devices

Initiating devices include the following:

- FST intelligent heat detectors, FSP or FSI intelligent smoke detectors, or
- Conventional detection devices which are UL-listed for initiating applications and connected to monitor modules.

Multiple initiating devices can be used for the same releasing hazard by mapping them to the same releasing zone. Factory Mutual and certain local authorities having jurisdiction (LAHJ) require use of redundant wiring (NFPA 72 Style 6 or Style D) for the initiating devices in releasing applications.

D.2.12 Warning Sounders

Warning sounders are audible devices (such as bell and horns) that connect to Notification Appliance Circuits or to control module circuits. Multiple Notification Appliance Circuits may be activated by the same releasing hazard.

Note: If your application requires coded signals (such as Temporal, March Time, and so on), connect the warning sander through one of the four panel Notification Appliance Circuits—not a control module circuit.

Program a warning sander to activate as follows:

- To activate when the delay timer starts, when the releasing device activates, or both: map the control module to the releasing zone (Z91, Z92, Z93, or Z94). If also selecting the releasing zone for cross zoning, a warning sander only activates when two releasing zones go into alarm (refer to Table 55 on page 149). Unlike releasing solenoids, however, warning sounders do not wait for the delay timer.
- To activate when any of the initiating devices activate: map the control module to a separate zone (not Z91, Z92, Z93, or Z94) that is also mapped to all initiating devices of the hazard.

D.2.13 Auxiliary Control Relay Functions

You can also use control relays for releasing applications. To do so, set control modules for dry contact operation (refer to Table 24 on page 83). Control relays can be programmed for different functions, just like warning sounders as described above. Also, you can map RTM-8 modules or ACM-8Rs to control panel software zones to provide control functions.

D.2.14 ACS Annunciation

ACS point annunciation of releasing functions can be done by annunciating any of the software zones described above, including zones Z91, Z92, Z93, and Z94. To set ACS annunciation of individual detectors, assign each detector to a separate software zone and annunciate the zone.

D.2.15 Deluge/Pre-Action Release

Installing Deluge and/or Pre-Action applications requires a wiring configuration that maintains a minimum voltage on releasing circuits. To calculate maximum allowable resistance, use the formula shown in Figure 144:

$$R_{\max} = \frac{V_D}{I_S}$$

Where:

R_{\max} = maximum allowable resistance of wiring

V_D = allowable voltage drop

I_S = solenoid current

Figure 144 Formula for Calculating Maximum Resistance

Note:

- Factory Mutual requires 90 hours of standby power, Style D (Class A) wiring on all Initiating Device Circuits and $V_D = 0.2$ VDC.
- For NFPA 13 and 15 applications, the soak timer must be disabled.
- For NFPA 16 applications, the soak timer may be set to 10 or 15 minutes.
- For UL-listed and FM-approved Solenoid Release Valves, refer to the Device Compatibility Document.
- Do not program an abort switch for deluge/pre-action applications.

D.3 Connecting Releasing Devices

This section contains typical wiring diagrams for the following releasing applications:

- Connecting a releasing device to a control panel through a control module (Figure 145 on page 154)
- Connecting the control panel to an agent release abort station (Figure 146 on page 155)

D.3.1 Connecting a Releasing Device to a Control Panel through an SLC Control or Relay Module

Figure 145 shows typical connections of releasing device to the control panel to a via a control or relay module.

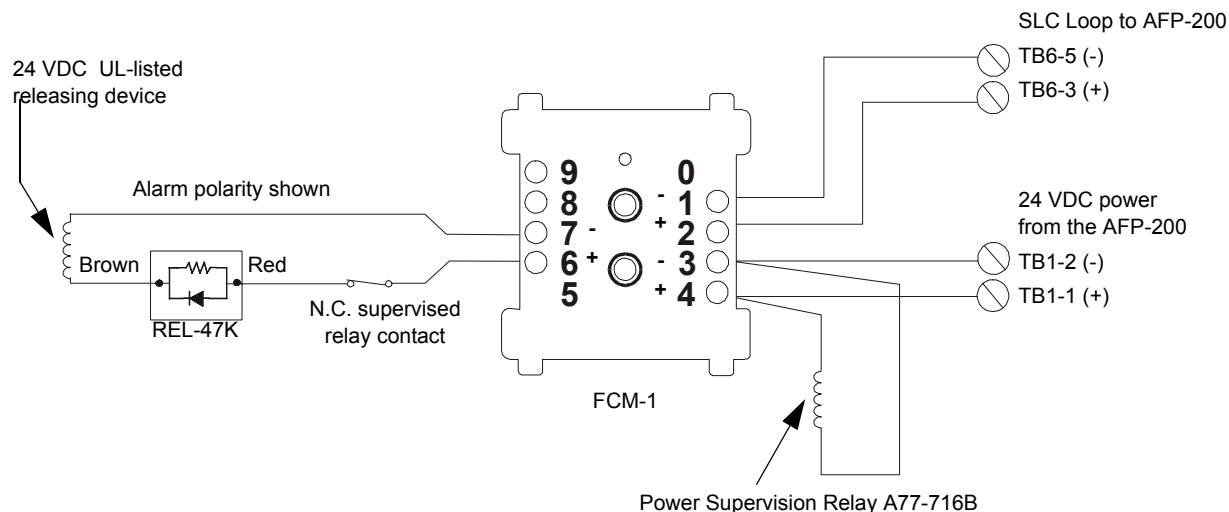

Figure 145 Typical Connection of Releasing Device to Control Module

D.3.2 Connecting an NBG-12LRA Agent Releasing Abort Station

Figure 146 shows typical connections for wiring an NBG-12LRA Agent Releasing Abort Station to the AFP-200. All wiring for releasing circuits is supervised against opens and shorts.

When connecting this type of circuit, follow these instructions:

1. For releasing applications, use an end-of-line device (part number REL-47K) with the control module.
2. Connect the end-of-line device as shown in Figure 146.
3. Program the control module or NAC for a *Rel Ckt ULC* type code.

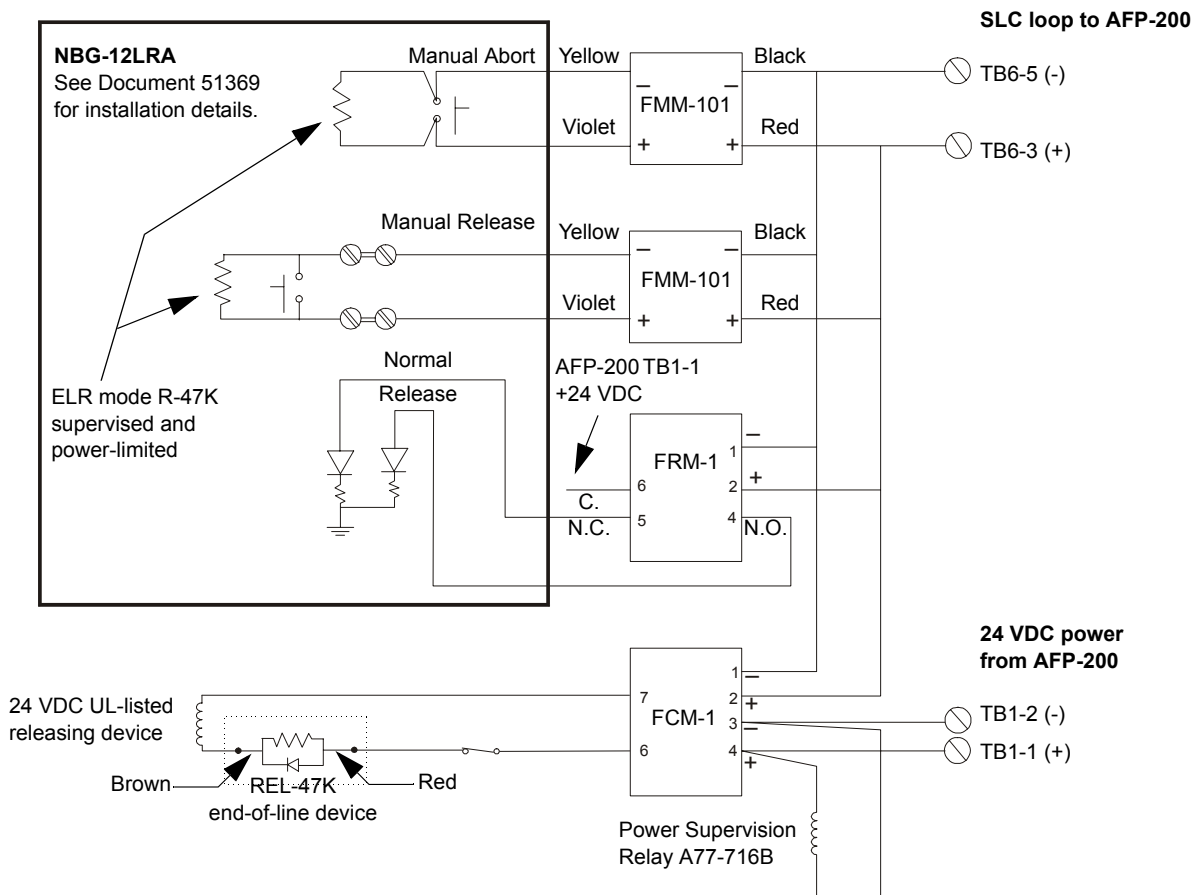

Figure 146 Typical Connections for an Agent Release-Abort Station

Note:

- For releasing applications use an end-of-line device (part number REL-47K) with the control module.
- All wiring for releasing circuits is supervised against open and shorts.
- Connect the end-of-line device as shown in Figure 146.
- Program the module or NAC for REL CKT ULC type code.

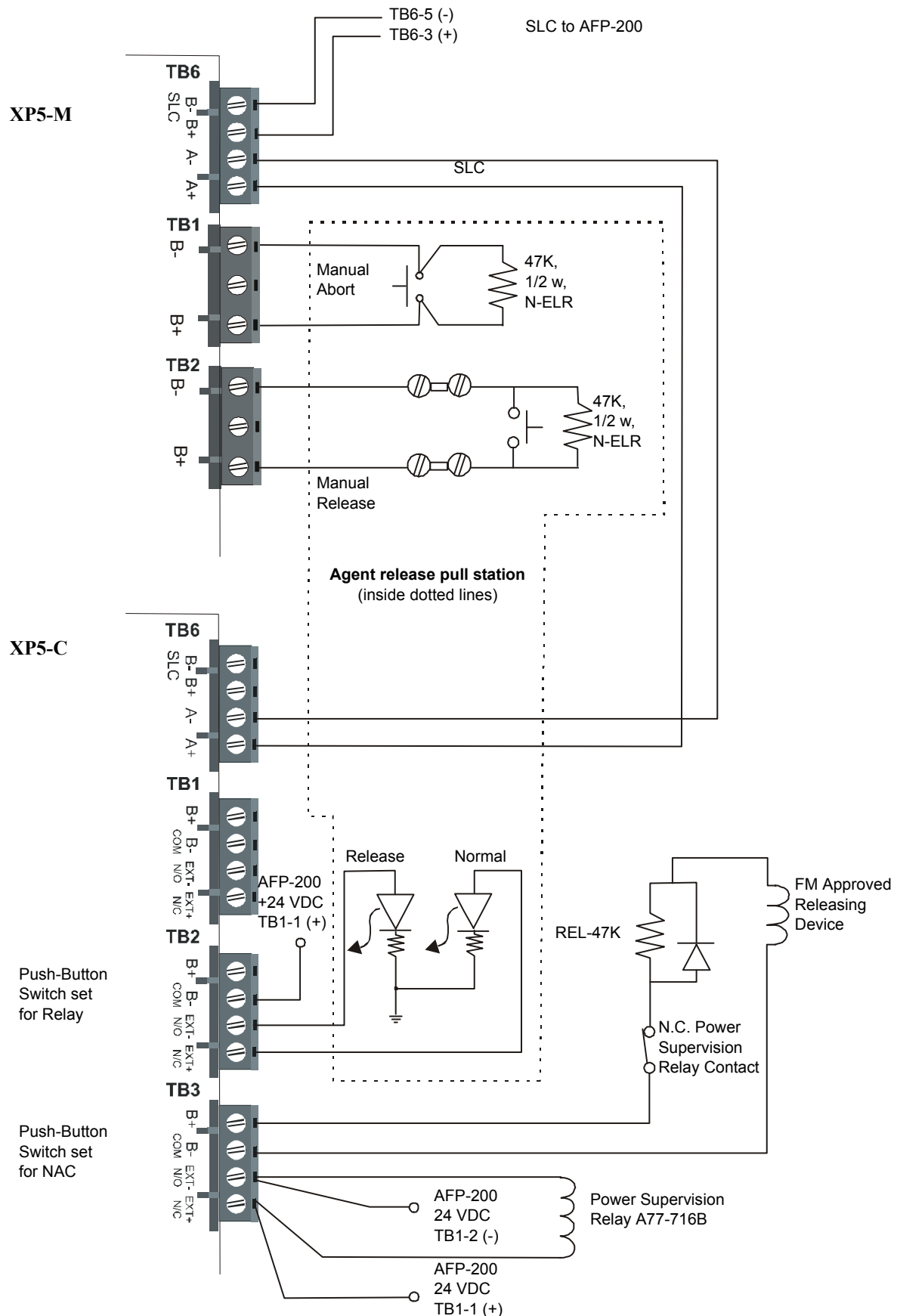

Figure 147 Employing NBG-12LRA Agent Release-Abort Station with XP5 Modules

Appendix E Combination Fire/Burglary Applications

E.1 Overview

The control panel can be used as a combination Fire/Burglary and Burglary system when installed, programmed, and operated according to the following:

Task	Refer to
Install an STS-200 Door Tamper Switch	Figure 148 on page 158
Wire the control panel for a security application	Figure 149 on page 159
Program a Monitor Module for a security application	Figure 150 on page 160
Configure the control panel keypad for a security application	Figure 150 on page 160

Table 58 Security Application Requirements

Notes for Table 58:

1. The control panel uses the same trouble input connector for the door tamper switch (STS-200), the APS-6R, and the AVPS-24. If an APS-6R or AVPS-24 is installed and programmed, therefore, do not use the control panel in Fire/Burglary applications.
2. A Combination fire/burglary listing does not include supervisory service.
3. A security type circuit is designed to indicate an alarm on an open or short circuit, or a resistance change of 50% (plus or minus) from the end-of-line resistor value. A tamper switch installed in the cabinet will also indicate a security alarm whenever the door is opened.

E.2 Installation

E.2.1 Installation Overview

Installing a combination Fire/Burglary application includes the following tasks:

- Installing a Tamper Switch.
- Wiring for Proprietary Security Alarm Applications.
- Connecting to an AM2020/AFP1010 Receiving Unit.

E.2.2 Installing a Tamper Switch

Wire the control panel with the STS-200 security tamper switch kit. To do so, follow these instructions:

1. Mount the STS-200 to the cabinet (Figure 148).
2. Run the wiring behind the CPU board (Figure 148).
3. Cut Jumper JP3.

4. Plug connector from STS-200 into J11

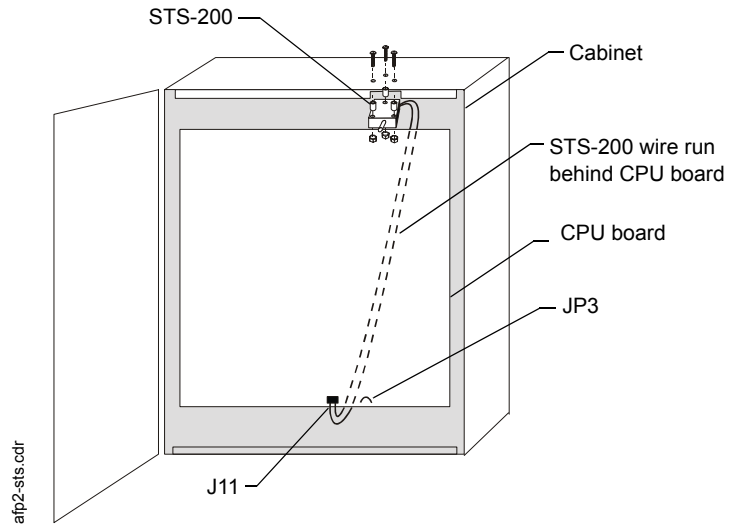

Figure 148 Typical Installation of an STS-200 Tamper Switch

E.2.3 Wiring for Proprietary Security Alarm Applications

Figure 149 shows typical wiring for proprietary security alarm applications with a control module configured as a Notification Appliance Circuit. Note the following:

1. The control module is configured as a Notification Appliance Circuit and programmed in the Protected Premises Unit.
2. Supplementary use only applies to UL-listed systems.

Refer to Device Compatibility Document 15378 for compatible Notification Appliance Circuits.

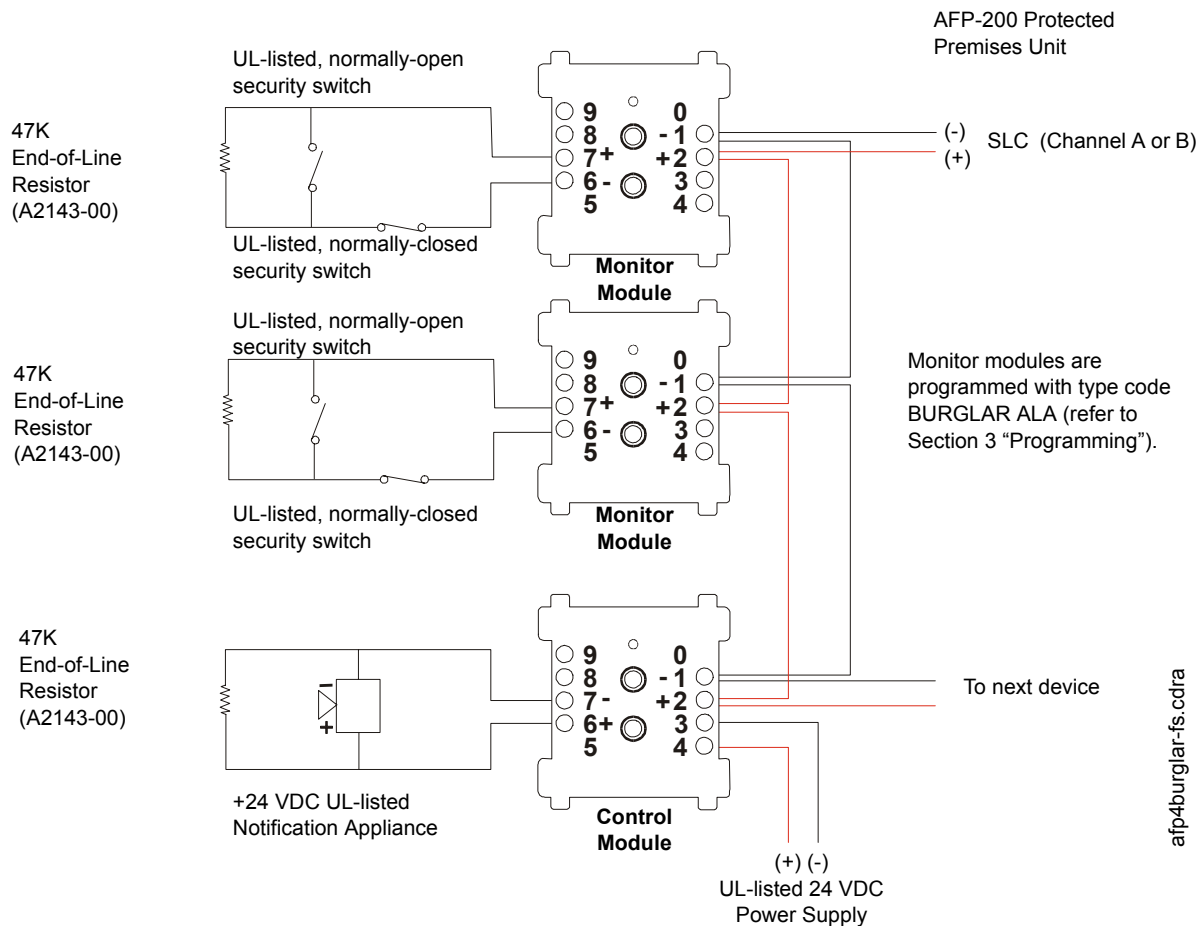

Figure 149 Wiring Diagram for Proprietary Security Alarm Applications

E.2.4 Connecting to an AM2020/AFP1010 Receiving Unit

For applications requiring transmission of burglary alarm information to a central receiving unit, do the following:

1. Connect the control panel to an AM2020 or AFP1010 provided with a NIB-96 network interface board. Burglar alarm zones are reported to the AM2020/AFP1010 through the NIB-96 Network Interface Board (for installation instructions, refer to Appendix B).
2. Configure the AM2020/AFP1010 for Combination Fire/Security applications. For instructions, refer to the installation section of the AM2020/AFP1010 manual.
3. Program the AM2020/AFP1010 networked monitor points as SARM type code (security alarm).

E.3 Programming

Program the control panel to select any number of Burglar Alarm type code devices (refer to Section 3 “Programming”). To program a point used for security, follow these instructions:

1. Select the address of a monitor module used for security.
2. Set the monitor module type code to BURGLAR ALA.

3. If needed, program additional sounders or output devices to activate when a security condition occurs.

Repeat steps 1–3 for each monitor module security device. You can also use the Disable/Enable function to bypass security zones for burglar applications.

E.4 Operation

E.4.1 Overview

A security type circuit indicates an alarm on an open or short circuit, or a resistance change of $\pm 50\%$ from the end-of-line resistor value. Security signals latch and may have their own Control-by-Event. They do not cause resound of alarms or reactivation of silenced alarm CBE. Supervisory circuits may also report open circuit troubles, which operate like any other trouble. The security LED reports the same as a supervisory LED, but the LCD display will show the BURGLAR ALA type code.

E.4.2 Configuring the Keypad for a Security LED Indicator

The control panel is supplied with a unique security keypad slide-in label for combination fire/burglary applications. This security label is identical to the standard slide-in label, except the fourth label position shows “Security” in place of “Supervisory”. On any burglar alarm, the Supervisory LED, as well as normally-open contacts on TB3 terminal 1 and TB3 terminal 2, will activate.

Note: A combination fire/burglary listing does not include supervisory service.

E.4.3 Control Panel Operation in a Security Condition

A security condition, activated by a monitor module programmed as BURGLAR ALA, causes the following to occur:

- The yellow Security LED lights.
- The panel LCD display indicates a burglar alarm or door tamper condition (Figure 150).

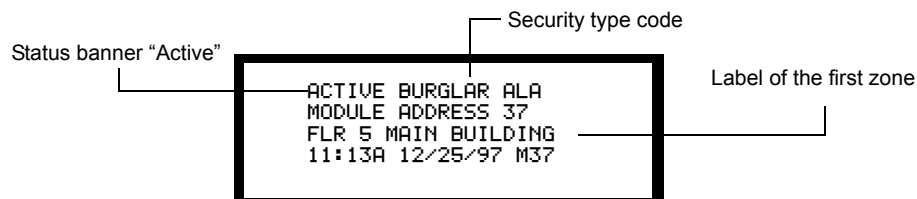

Figure 150 Typical Panel LCD Display in a Security Condition

- The panel sounder pulses until acknowledged.
- Additional sounders or output devices programmed to activate on security condition.

When the system is reset a 30-second exit timer starts. During this time, the tamper switch and all burglar alarm type alarms are ignored. There is no entrance delay timer.

Appendix F Wire Requirements

Each type of circuit within the fire alarm control system must use a specific type of wire to ensure proper operation. Also, the wire gauge of a particular circuit depends on the length of that circuit. Use the table below to determine the specific wiring requirements for each circuit.

Note: If running the SLC loop in conduit with Notification Appliance Circuits, you can reduce the risk of encountering problems by exclusively using electronic sounders (such as the MA/SS-24I) instead of more electronically noisy notification appliances (such as electromechanical bells or horns).

Circuit Type	Circuit Function	Wire Requirements	Distance	Typical Wire Size
SLC Loop (power-limited)	Connects to intelligent and addressable modules	Twisted-shielded pair, 12 to 18 AWG. 40 ohms maximum per length of Style 6 and 7 loops. 40 ohms per branch maximum for Style 4 loops	<ul style="list-style-type: none"> • 10,000 ft (3048 m) • 8,000 ft. (2438.4m) • 4,875 ft. (1485.9 m) • 3,225 ft. (982.98 m) 	<ul style="list-style-type: none"> • 12 AWG • 14 AWG • 16 AWG • 18 AWG
		Untwisted, unshielded wire, in conduit or outside of conduit Note: Maximum total capacitance of all SLC wiring (both between conductors and from any conductor to earth) should not exceed 0.5 microfarads.	<ul style="list-style-type: none"> • 1,000 ft. (304.8 m) 	<ul style="list-style-type: none"> • 18-12 AWG
EIA-485 (power limited)	Connects to LCD-80 or to Annunciator Control System modules	Twisted-shielded pair with a characteristic impedance of 120 ohms, 18 AWG minimum	<ul style="list-style-type: none"> • 6,000 ft. (1828.8 m) (max) 	<ul style="list-style-type: none"> • 16 AWG
EIA-232 (power-limited)	Connects to PRN or P40 Remote Printers and to a DOS-based personal computer	Twisted-shielded pair 18 AWG minimum	<ul style="list-style-type: none"> • 50 ft. (15.24 m) (without modem) 	<ul style="list-style-type: none"> • 16 AWG
Monitor Modules (power-limited)	Initiating Device Circuit (IDC)	12-18 AWG Maximum loop wire resistance is 20 ohms	<ul style="list-style-type: none"> • To meet 20 ohms 	<ul style="list-style-type: none"> • 12-18 AWG
Control Module (power-limited)	Notification Appliance Circuit (NAC)	12-18 AWG At alarm current level, no more than a 1.2 V drop at the end of the circuit	<ul style="list-style-type: none"> • To meet 1.2 V drop 	<ul style="list-style-type: none"> • 12-18 AWG
	To annunciators and control modules	12-18 AWG Size wire so that no more than 1.2 V drop across wire run from supply source to end of any branch	<ul style="list-style-type: none"> • To meet 1.2 V drop 	<ul style="list-style-type: none"> • 12-18 AWG
NR45-24	Remote secondary power source	12 AWG in conduit	<ul style="list-style-type: none"> • 20 ft. (6.096 m) (max) 	<ul style="list-style-type: none"> • 12 AWG

Table 59 Wiring Requirements

Appendix G Pre-Alarm (AWACS™) Applications

G.1 Overview

The control panel includes a facility to give early warning of incipient or potential fire conditions (U.S. Patent Pending). This is a two-level (Alert and Action) Pre-Alarm function called AWACS™ (Advance Warning Addressable Combustion Sensing).

G.2 Pre-Alarm Applications

G.2.1 Pre-Alarm Alert Level

The control panel software, in addition to checking for alarm levels, checks for Pre-Alarm thresholds for each ionization or photo smoke detector (not analog thermal detectors). If a Pre-Alarm level is reached that exceeds the programmed Alert or Action threshold, the appropriate condition appears on the panel display.

Alert Level Functions

The system performs the following functions when a detector reaches an Alert level:

- The Pre-Alarm LED flashes and the panel sounder pulses until acknowledged.
- An Alert message is sent to the history file and to installed peripheral devices, such as the LCD-80 and printer. The Alert message is also time-stamped (with the time that the Alert occurred) to provide historical data about the progress of a fire.
- Zone 99 activates. No other zones or relays activate.
- The Pre-Alarm indication automatically restores to normal if its sensitivity drops below Alert level. Zone 99 clears automatically when no Pre-Alarm conditions exist.
- A subsequent alarm, or an Action level condition for this detector will clear the Alert indication.

Example of a Pre-Alarm Alert Condition

Figure 151 shows a sample panel display of a photoelectric detector that reaches the Pre-Alarm Alert condition. In this example, zone 99 is programmed to Alert= 40% of Alarm. An Alert will occur at measured smoke levels that exceed $0.40 \times 2.0\%$ per foot (30.48 cm) obscuration (low) = 0.80% per foot (30.48 cm) obscuration.

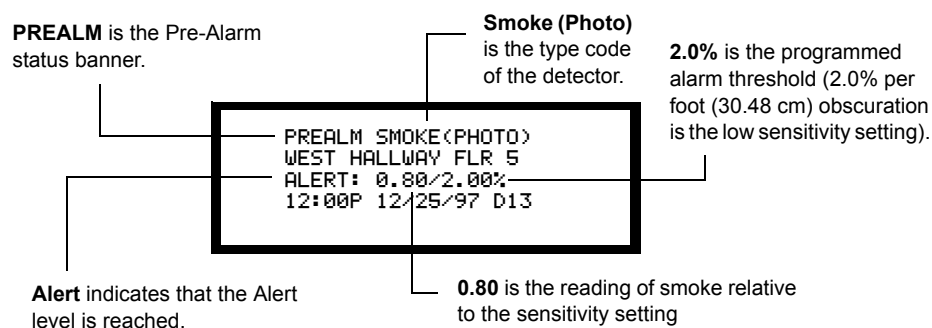

Figure 151 Sample Screen in Alert Condition

0.80 is a real-time display, updated every few seconds, to show the current reading of this detector. In this example, the reading equals 40% of alarm, which puts the control panel into Alert condition.

G.2.2 Action Level Pre-Alarm Function

Action Level Functions

If a detector reaches a level that exceeds the programmed Action threshold, an Action condition is indicated. The following functions are performed at Action level:

- The message is sent history file and to installed peripheral devices, such as the LCD-80 and printer.
- The Pre-Alarm LED and panel sounder pulse until acknowledged.
- Zone 99 activates. No other zones or relays activate.
- The fifth zone programmed (not the first four) for this detector is activated. The fifth zone is the right-most entry on line three of the point programming screen. This zone may be used to control functions of a detector or group of detectors on Action level. The fifth zone activations will also allow ACS annunciation by a detector or group of detectors in Action Pre-Alarm state.
- The Pre-Alarm condition and the zone programmed latch until System Reset, even if the sensitivity drops below the Action or Alert level.
- A subsequent alarm condition for this detector clears the Action indication from the panel LCD display and Pre-Alarm LED, but will not reset the fifth zone (the fifth zone is also on the alarm list).

Example of a Pre-Alarm Action Condition

Figure 152 shows a sample panel display that appears if a detector is in Action level. In this example, zone 99 is programmed for Action = 60% of Alarm. Any measurement that exceeds 1.20% (0.60 X 2.00%) causes an Action Pre-Alarm condition.

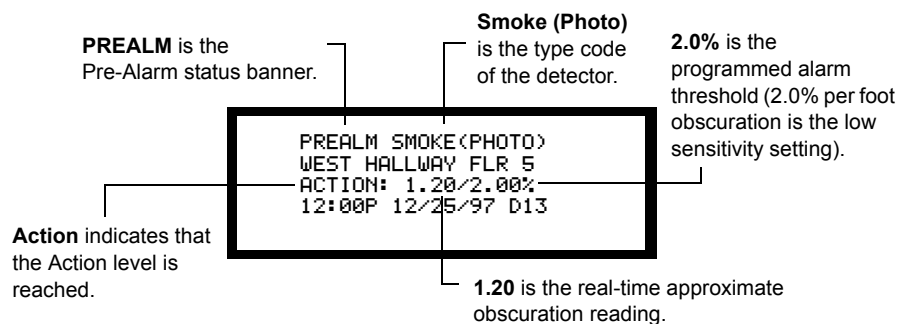

Figure 152 Sample Screen of an Action Level

G.3 Pre-Alarm Programming

G.3.1 Pre-Alarm Programming Screen

You can adjust the setting of the two Action and Alert levels (from 00% to 99%) to suit your application. From the Special Zone Change screen (Figure 74 on page 87), select

99=Prealm. Figure 153 shows a sample panel display of the Pre-Alarm screen with default Alert and Action Pre-Alarm levels:

Alert=70% of Alarm means that every photo and ion detector will give an Alert indication when its sensitivity reaches 70% of its alarm level (default setting).

Status banner for Pre-Alarm Zone 99

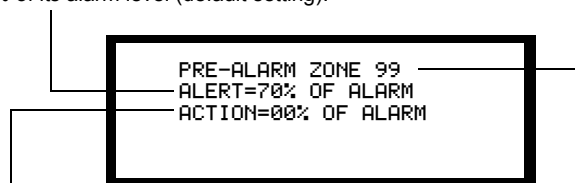

Action=00% of Alarm – no Pre-Alarm Action level selected in the system (default setting)

Figure 153 Sample Display of Pre-Alarm Screen with Default Values

When programming Pre-Alarm settings, note the following:

- The Alert default is 70%.
- The default value for Action is 00%. ACTION=00% means no Pre-Alarm, therefore the default is no Action level.
- Allowable settings for Alert and Action are 00% to 99%.
- The control panel software ensures that the Action level is higher than the Alert level (or the Action level is zero) and that both are below 100%.

G.3.2 Selecting Pre-Alarm Application Levels

Alert and Action Pre-Alarm levels are global settings, meaning they apply to all photoelectric or ionization detectors. You can, however, select different Action levels as detailed below. Figure 154 shows typical AWACS™ application threshold levels:

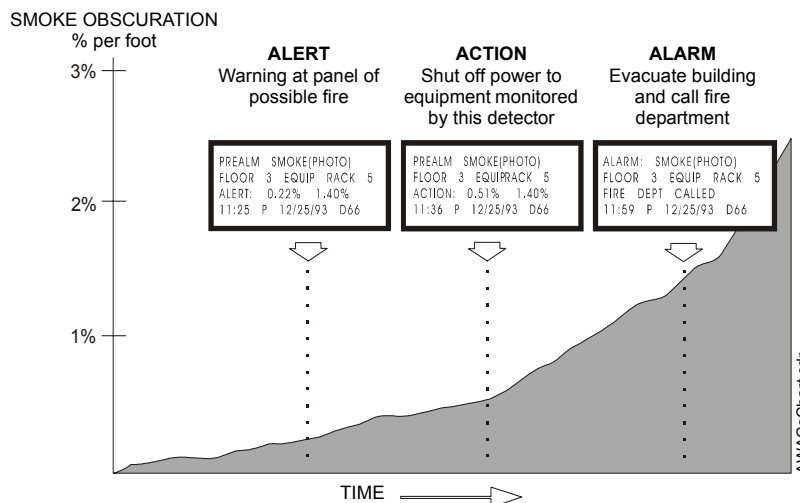

Figure 154 Typical AWACS™ Application Threshold Levels

Selecting Different Action Levels

You can select different Pre-Alarm Action levels for each detector by selecting different alarm levels. For example, two detectors, D13 and D14, are connected to a control panel with a global Alert level set to 50% of alarm. Select different Pre-Alarm levels as follows:

- Detector D13 – Set to alarm at 2.00%, D13 so it will Pre-Alarm at 1.00% per foot (30.48 cm) obscuration.
- Detector D14 – Set to alarm at 1.00%, so it will Pre-Alarm at 0.50% per foot (30.48 cm) obscuration.

Latching and Non-Latching Pre-Alarm Levels

Some applications only require one level of Pre-Alarm, but the Pre-Alarm must be latching. To program a **latching** (non-restoring) Pre-Alarm, select ALERT=00% and select an Action level. To program a **non-latching** (self-restoring) Pre-Alarm, select ACTION=00% and only select an Alert level.

Note: Only the Action level will provide ACS point annunciation.

G.3.3 Self-Optimizing Pre-Alarm Function

Note: Self-Optimizing Pre-Alarm mode only operates with FSP-751 photoelectric detectors. Self-Optimizing Pre-Alarm does not function when selected for ionization detectors.

Description

The control panel software (PN 73609 or higher) includes a Self-Optimizing Pre-Alarm selection, where the control panel automatically sets the optimal Pre-Alarm sensitivity for each photoelectric detector (FSP-751). When a detector senses smoke above the calculated optimal Pre-Alarm level, the control panel latches into an Action Level Pre-Alarm (refer to Figure 155 on page 165). The software compensates for electrical noise transients, dust buildup, and other environmental factors.

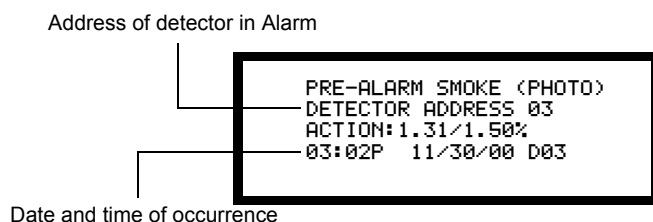

Figure 155 Sample of Action Level Pre-Alarm

Applications include computer rooms, electrical equipment rooms, and telecommunication facilities where environments are clean and stable and early warning is essential. Self-Optimizing mode is not recommended for applications (such as cigarette smoking areas) where false smoke indications are present.

Programming

You can select Self-Optimizing for a photoelectric detector as follows:

1. From the Special Zone Change screen, select the 99=PREALM to display the Pre-Alarm screen as shown in Figure 156.

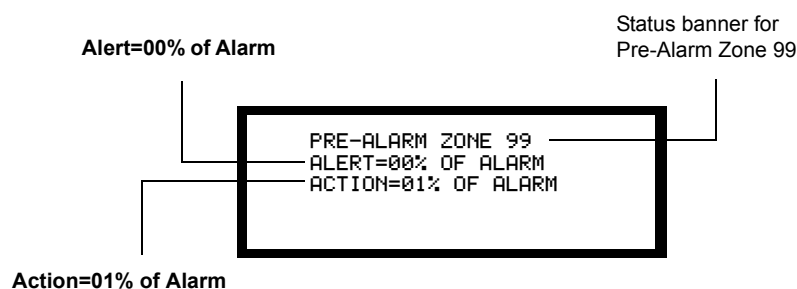

Figure 156 Sample Pre-Alarm Screen with Self-Optimizing Settings

2. Set Pre-Alarm settings: ALERT=00 and ACTION=01 as shown in Figure 156.
3. Program each detector for which Pre-Alarm is desired. Figure 157 shows a sample screen for a detector selected for Pre-Alarm. For detailed information on point

programming, refer to Section 3 “Programming”.

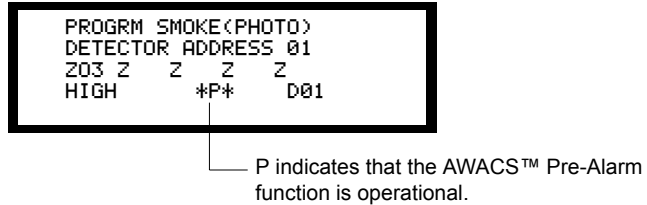

Figure 157 Point Programming Screen with Pre-Alarm Selected

The control panel will determine the optimal Pre-Alarm Action Level sensitivity for each detector selected, after approximately 10 minutes of data sampling.

G.3.4 Audible Warning Applications for AWACS™

A sounder base may be used with AWACS™ to give a local audible warning before general evacuation. This may be used to reduce the impact of false alarms from cooking, smoking, etc. in a multiple unit housing application. An individual in the apartment would receive advanced audible warning and could eliminate the source of the pending false alarm.

The control panel will activate the LEDs on the photoelectric or ionization detectors on a Pre-Alarm condition (Alert level or Action level). The detectors LEDs are used to drive the sounder base. When the LEDs on the detector light steadily for 10 seconds the sounder base will activate. If latching operation of the sounder base is desired, program the control panel for Action Pre-Alarm. If non-latching (self-restoring) operation is desired, program the system for Alert Pre-Alarm operation. If all sounder-bases are to activate on alarm, wire the power for these bases through two relay-module relay contacts that will reverse the polarity to the sounder bases on alarm.

Appendix H Special Zones

H.1 Overview

This appendix provides descriptions and options for the following Special Zones:

Special Zones	Used to define...
Z90	Presignal and PAS selections
Z95, Z96, Z97	Time Control selection, Holiday selections
Z98	NAC Code Types

Table 60 Special Zones

Note: Special Zones 91–94 are covered in Appendix D “Releasing Applications”. Special Zone 99 is covered in Appendix G “Pre-Alarm (AWACSTM) Applications”.

H.2 Presignal and Positive Alarm Sequence (PAS)

The control panel delays activation of outputs containing Z90 in their Control-By-Event (CBE) equation for all alarm initiating devices that contain Z90 in their Control-By-Event equation. A subsequent alarm will abort the delay and execute CBE equations. If using Z90, note the following:

- Do not include Z90 in the CBE equation for a releasing device.
- Z90 must be mapped to all participating outputs.
- Abort circuit activation by pressing Alarm Silence before the delay expires.

H.2.1 Presignal

You can set Presignal delay time between 60 and 180 seconds. Presignal delay does not apply to the following:

- the System Alarm relay;
- the 4XTM polarity reversal alarm output;
- the 4XTM municipal box output; and
- the RTM-8 output.

H.2.2 Positive Alarm Sequence (PAS)

Do not include Z90 in the CBE equation for any monitor module that connects to a device other than an automatic fire detector. NFPA 72 requires installation of a PAS Inhibit switch. To do this, use a monitor module with type code “PAS Inhibit.”.

Selected outputs (set to PAS=Y) delay for 15 seconds. Pressing Acknowledge within the 15-second delay increases the delay to the full programmed value (60–180 seconds). When an alarm comes from an initiating device with a CBE equation that includes Z90, the control panel delays the following outputs:

- the System Alarm relay;
- the 4XTM Polarity Reversal Alarm output; and
- the 4XTM Municipal Box output.

Note: PAS will not delay RTM-8 relay outputs.

H.3 Time Control

Note: All active Time Control outputs will turn off temporarily while resetting or programming the control panel.

All outputs with a CBE equation containing Z95 or Z96 activate within the times specified for the days of the week listed in Z95 or Z96. All smoke detectors with a CBE equation containing Z95 or Z96 switch to their lowest sensitivity (2.0%) within the times specified for the days of the week listed in Z95 or Z96.

Time Control is active for all days of the week listed in Z95 or Z96. Holidays listed in Z97 are excluded unless you list Holidays (H) in the day-of-week selection. Enter the time in a 24-hour format with the OFF time later than the ON time. After changing programming using Time Control, always reset the control panel.

H.4 NAC Code Types

Control panel Notification Appliance Circuits with a CBE equation that includes Z98 are coded when activated by a fire alarm. These circuits are steady when activated exclusively by an initiating device with a Hazard Alert Type Code. If using these NACs for releasing or zone coding, do not include Z98 in the CBE equation. Select the code type on a system basis, through special zone Z98. Table 61 contains coding selections:

Code Type	Signal
March Time (default)	120 PPM (Pulses Per Minute)
Two-Stage	Alert signal – 20 PPM; General alarm signal: Temporal (see Note below).
Two-Stage Canada 3	Alert signal – 20 PPM; Drill Switch: Temporal Timer: 3 minutes
Two-Stage Canada 5	Alert signal – 20 PPM; Drill Switch: Temporal Timer: 5 minutes
California	10 sec. on, 5 sec. off, repeats
Temporal	0.5 sec. on, 0.5 off, 0.5 on, 0.5 off, 0.5 on, 1.5 off, repeats

Table 61 NAC Code Type Selections

Note: The control panel automatically sends an alert signal to any of the four Notification Appliance Circuits mapped to Z00 and Z98, but not mapped to the alarm signal. After 5 minutes without an Acknowledge or Silence, the alert signal becomes Temporal pattern.

Two-stage Canada functions like standard Two-Stage except only the Manual Evacuate will cause NAC to go to second stage. If acknowledge is pressed on first stage, timer will not time out. Subsequent alarm will restart timer.

Appendix I Terminal Interface Protocol

I.1 General Description

The control panel can communicate with a remote terminal or computer connected to the CPU EIA-232 port. (Refer to Section 2 “Installation” for installation information.) Set up the EIA-232 port for interactive operation or for monitoring only. Interactive operation requires that all equipment be UL-listed under UL Standard for Safety UL864 and be installed and set up as directed under Local Terminal Mode (LocT) or Local Monitor Mode (LocM). EDP listed equipment is allowed for ancillary system monitoring when the system is installed and set up as directed under Remote Monitor Mode (RemM). You can also use EDP-listed equipment for system servicing or programming.

The EIA-232 ports on some terminals/computers, including the CRT-2, are not isolated from earth ground. These devices should be connected to the control panel through isolation modems, because direct connection can cause a ground fault.

I.2 Operating Modes

The control panel provides three operating modes for the EIA-232 port, Local Terminal (LocT), Local Monitor (LocM), and Remote Monitor (RemM). You select the operating mode during control panel programming (system parameters). For more information, refer to Section 3 “Programming”.

The following subsections outline the functions, password requirements, and additional information for each operating mode.

I.2.1 Local Terminal Mode (LocT)

Functions, passwords, and special requirements of Local Terminal Mode (LocT) are:

- Functions:** Read Status, Alter Status, and Control Functions.
- Passwords:** User-defined password for Alter Status functions.
- Requirements:** The terminal must be mounted in a UL-864 listed enclosure, a Notifier Rack-51, Rack-67, or positioned to provide equivalent protection against unauthorized use.

Table 62 below summarizes the functions available with the Local Terminal mode:

Function	Lets you...
Read Status	<ul style="list-style-type: none"> • Display the status of an individual point (detector, module, panel circuit, or zone) • Display a list of all the points in alarm or trouble • Display a list of all programmed points in the system • Step through the history buffer event by event • Display the entire history buffer
Alter Status	<ul style="list-style-type: none"> • Disable/Enable an individual point • Change the sensitivity of a detector • Clear the verification counter of all detectors • Clear the entire history buffer • Set the AWACS™ alert and action levels
Control Functions	<ul style="list-style-type: none"> • Acknowledge • Alarm Silence • System Reset • Drill

Table 62 LocT Functions

I.2.2 Local Monitor Mode (LocM)

Functions, passwords, and special requirements of Local Monitor Mode (LocM) are:

Functions: Read Status, Alter Status, and Control Functions.

Passwords: User-defined password for Alter Status and Control functions.

Requirements: Password security feature for Control Functions eliminates the need for mounting the CRT-2 in an enclosure.

Table 63 summarizes the functions available with the Local Monitor mode:

Function	Lets you...
Read Status	<ul style="list-style-type: none"> • Display the status of an individual point (detector, module, panel circuit, or zone) • Display a list of all the points in alarm or trouble. • Display a list of all programmed points in the system • Step through the history buffer event by event • Display the entire history buffer
Alter Status*	<ul style="list-style-type: none"> • Disable/Enable an individual point • Change the sensitivity of a detector • Clear the verification counter of all detectors • Clear the entire history buffer • Set the AWACS™ alert and action levels
Control Functions*	<ul style="list-style-type: none"> • Acknowledge • Alarm Silence • System Reset • Drill
*Requires the user defined password for access.	

Table 63 LocM Functions

I.2.3 Remote Terminal Mode (RemT)

Functions, passwords, and special requirements of Remote Terminal Mode (RemT) are:

Functions: Read Status only. See Table 64.

Passwords: None

Requirements: Use with UL EDP-listed terminals, including personal computers with Veri•Fire™ Upload/Download software or terminal emulation software. Intended for terminals connected through modems, including Notifier TPI modems connected through a public switched telephone network.

Table 64 summarizes the functions available with the RemT mode:

Functions	Lets you...
Read Status	<ul style="list-style-type: none"> • Display the status of an individual point (detector, module, panel circuit, or zone) • Display a list of all the points in Alarm or trouble • Display a list of all programmed points in the system • Step through the history buffer event by event • Display the entire history buffer
Alter Status	N/A
Control Functions	N/A

Table 64 RemT Functions

I.3 Using the CRT-2 for Read Status

I.3.1 Overview

This section shows how to perform the Read Status functions from a CRT-2.

Function	Lets you...
Read Point	Read the status of any point in the system (detectors, modules, bell circuits, software zones, and system parameters).
Alm/Tbl Status	Display a list of all devices in the system that are in Alarm or trouble.
Read All Points	Display a list of all points programmed in the system. This list will display the status of all addressable detectors, modules, NACs, system parameters and software zones.
History Step	Step through the history buffer one event at a time.
History-All	Send the entire history buffer to the CRT, from the most recent event to the oldest event.

Table 65 Read Status Functions

I.3.2 Accessing Read Status Options

Access the Read Status function from the CRT-2 by following these steps.

1. Turn on the CRT-2, which is connected to the control panel.
2. Press the Read Status function key – F1. The control panel displays the Read Status menu options:

Press



Read Point=1 Alm/Tbl Status=2 Read All Points=3 History Step=4/All=5

From the Read Status menu, you can select options 1-5.

I.3.3 Read Point

From the Read Status menu, select Read Point, option 1. The CRT-2 displays the following:

Press



```

Enter D(Det.) / M(Mod.) / B(Bell) / Z(Zone),AA or S(System params.)
  
```

Enter the following:

1. Enter the first letter of the device.

- **D**etector
- **M**odule
- **B**ell circuit
- **Z**one or
- **S**ystem Parameter.

2. Enter the address or number of the device.

3. Press <Enter>.

Example Read the point for detector at address 29:

```

NORMAL SMOKE(PHOTO) DETECTOR ADDRESS 29 Z91 Z Z Z Z 0.00/2.00% *P* D29
  
```

```

TROUBL SMOKE(PHOTO) DETECTOR ADDRESS 30 Z91 Z Z Z Z 0.00/1.50% *P* D30
  
```

Press  to scroll forward through a list of devices.

Press  to scroll back through a list of devices.

Press

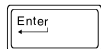

I.3.4 Display Devices in Alarm or Trouble

From the Read Status menu, select Alm/Tbl status, option 2:

Press



```

TROUBL HEAT(ANALOG) DETECTOR ADDRESS 06 Z91 INVALID REPLY 08:10A 08/20/97 D06
TROUBL SMOKE(PHOTO)DETECTOR ADDRESS 29 Z12 DEVICE DISABLED 08:10A 08/20/97 D29
TROUBL CONTROL          MODULE ADDRESS 21 Z00 OPEN CIRCUIT 08:10A 08/20/97 M21
  
```

I.3.5 Display the Status of all Programmed Points

From the Read Status menu, select Read All Points, option 3. The CRT-2 displays a list of the status of all addressable detectors, modules, bell circuits, system parameters and software zones:

Press

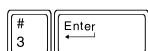

```

NORMAL HEAT(ANALOG) DETECTOR ADDRESS 32 Z32 Z Z Z Z 08:10A 08/20/97 D06
NORMAL MONITOR          MODULE ADDRESS 02 Z01 Z Z Z Z 08:10A 08/20/97 M02
OFF BELL CIRCUIT PANEL CIRCUIT NO.3 Z00 Z Z Z Z 08:10A 08/20/97 M02
  
```

I.3.6 View the History Buffer

From the Read Status menu, select History-Step, option 4. This option lets you step through the history buffer one event at a time:

Press



The first line that appears displays the most recent event in the history buffer.



Step through the history buffer one event at a time by pressing the Next (F5) or Prior (F6) function keys.

Press  to scroll forward through the history buffer.

Press  to scroll back through the history buffer.

I.3.7 Send the History Buffer to the CRT-2

From the Read Status menu, select History-All, option 5. This option sends the entire history buffer to the CRT-2, from most recent event to oldest event:

Press



Most recent event

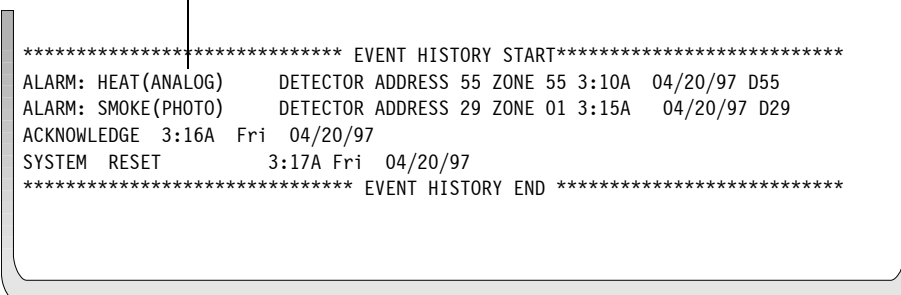

I.4 Using the CRT-2 for Alter Status

I.4.1 Overview

This section shows how to do Alter Status functions, Table 66, from a CRT-2.

Function	Lets you...
Disable	Enable or disable detectors, modules, or NACs.
Sensitivity	Change the sensitivity of any addressable detector in the system.
Clear Verification	Clear the verification counter for all the addressable detectors in the system.
Clear History	Clear the contents of the history buffer.
Set Action/Alert	Set the Pre-Alarm for the Alert or Action level.

Table 66 Alter Status Functions

I.4.2 Accessing Alter Status Options

Access the Alter Status function from the CRT-2 by following these steps.

1. Turn on the CRT-2 connected to the control panel.
2. Press the Alter Status function key. The control panel displays the Alter Status menu options:

Press



Enter Status Change Password or Escape to Abort

3. Enter the Status Change Password. The factory default Status Change Password is 11111. The password does not display on the CRT-2. Five asterisks will appear in place of the password:

Press

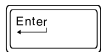
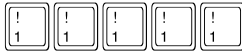

The Alter Status Options menu appears:

1=Disable 2=Sensitivity 3=Clear Verification 4=Clear History 5=Set Action/Alert

From the Alter Status Options menu, you can select options 1-5.

I.4.3 Enable or Disable Detectors, Modules, or Bell Circuits

From the Alter Status menu, select Disable, option 1. Disable lets you enable or disable detectors, modules, or bell Circuits:

Press



Disable/Enable D(Det.) / M(Mod.) / B(Bell ckt.), AA

Address or number

Enter the following:

1. Enter the first letter to read one of the following:
 - **D**etector
 - **M**odule
 - **B**ell Circuit (NAC)
2. Enter the address or number of the device.
3. Press <Enter> and a display similar to the following will appear.

Example Disable the NAC at address 1:

Press

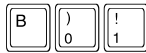

```
B01
```

4. Press <E> to Enable or press <D> to Disable; then press <Enter>:

Press

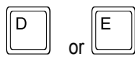

```
B01 Now Enabled, Enter E(Enable) / D(Disable) or Esc. to Abort
```

I.4.4 Change Detector Sensitivity Levels

This option lets you change the Alarm and Pre-Alarm levels of any addressable detector in the system. To do so, follow these steps.

5. From the Alter Status menu, select Sensitivity, option 2:

Press



```
Det. Sensitivity Enter point: AA, E
```

6. Enter the address of the detector you wish to change. For example, detector 57:

Press



```
D57 now Low sens. Enter H, M, or L to change, Esc. to Abort
```

I.4.5 Clear the Verification Counter

Clear Verification, option 3, lets you clear the verification counter for all the addressable detectors in the system:

Press

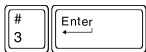

```
Press Enter to Clear Verification Counts or Esc. to Abort
```

I.4.6 Clear the Entire History Buffer

Clear History, option 4, lets you clear the entire history buffer:

Press



```
Press Enter to Clear History or Esc. to Abort
```

I.4.7 Set the Pre-Alarm for Alert or Action Level

Set Action/Alert, option 5, lets you set the Pre-Alarm for Alert or Action. For example, set Alert level=50% and the Action level=70% as follows:

Press



Set % of Alarm: Alert(T) and Action(N) Format: TxxNxx then Enter

Press



T50N70

I.4.8 CRT-2 Configuration

The CRT-2 must be set up to communicate with the control panel using the proper protocol. To enter the setup menu on the CRT-2, hold down the CTRL button while pressing the SCROLL LOCK key. There are thirteen groups of parameters that must be set. Each of these thirteen groups is reached by pressing the corresponding function key (F1 - F13). Use the arrow key to move through each setup group and use the space bar to view the options for each parameter.

Appendix J Expansion Power Supplies

J.1 Overview

Expansion power supplies provide additional power for notification appliances connected to NAC 3 and NAC 4 on the control panel. You can install one of the following expansion power supplies:

Expansion Power Supply	Description
Audio/Visual Power Supply (AVPS-24/AVPS-24E)	A 24 VDC unfiltered, unregulated power supply that supplies a maximum of 3.0 A to the notification appliances connected to NACs 3 and 4 combined. The maximum current from any one circuit, however, is limited to 2.5 A.
Auxiliary Power Supply (APS-6R)	An APS-6R (120 VAC or 240 VAC input) supplies power to NACs and provides two filtered, regulated, non-resettable 24 VDC outputs (3 A each, 6 A total, 4 A continuous).

Table 67 Expansion Power Supplies

An expansion power supply mounts in the battery compartment of the cabinet. Batteries must be relocated to the BB-17 Battery Box. This appendix contains instructions for mounting and wiring an AVPS-24 and APS-6R as well as instructions for programming the control panel.

WARNING: Because the AVPS-24/AVPS-24E supplies special purpose power that is unfiltered & unregulated, only compatible notification appliances listed in the Device Compatibility Document can be connected to NACs 3 and 4.

J.1.1 AVPS-24 Audio/Visual Power Supply

The AVPS-24 supplies power (unfiltered, unregulated, 3.0 A maximum) to Notification Appliance Circuits (NACs) and occupies one position on the CHS-4 chassis. A trouble cable is provided for connection to the control panel. The AVPS-24 mounts in the bottom of the AFP-200 cabinet. AC power required for the AVPS-24 is 120 VAC, 50/60 Hz, 1.0 A and AC power required for the AVPS-24E is 220/240 VAC, 50/60 Hz, 0.5 A. Figure 158 shows an AVPS-24 and the provided Power Cable

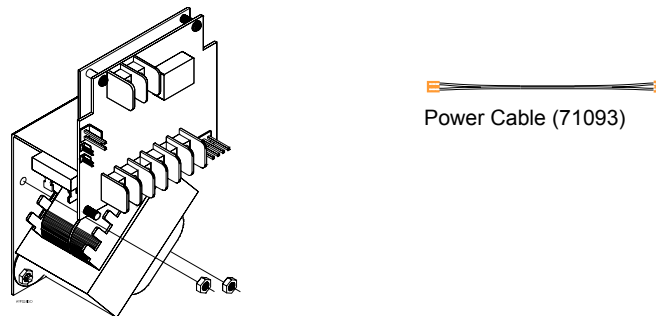

Figure 158 AVPS-24 Power Supply

J.1.2 APS-6R Auxiliary Power Supply

The APS-6R is a 150W cabinet-mounted power supply, designed to power devices that require filtered, regulated, non-resettable power, such as NACs and Control Modules. The APS-6R provides two 24 VDC (filtered) output circuits (3 A each, 6 A total, 4 A

continuous). The APS-6R mounts in the bottom of the AFP-200 cabinet. Figure 159 shows an APS-6R and the supplied Power Cable:

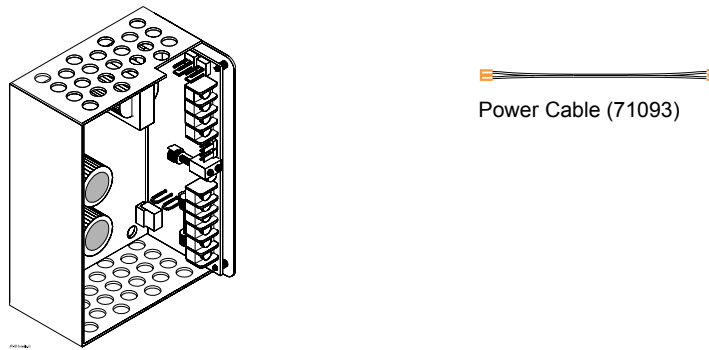

Figure 159 APS-6R Auxiliary Power Supply

Electrical Specifications

AC primary input power (TB1) Wire Size: #14 AWG with 600 VAC insulation

120 VAC, 60 Hz, 2.5 A
240 VAC, 50 Hz, 1.2 A

24 VDC Secondary input power (lead-acid batteries only)

TB3-1 (+) 25 mA DC standby current
TB3-2 (-) 16 mA DC standby current (with AC fail delay operating)

24 VDC output power (TB2) Total 6 A (4 A continuous)

Circuit 1 (TB2-1, TB2-2; or J1) 3 A @24 VDC power-limited (+10, -15%)
Circuit 2 (TB2-3, TB2-4; or J2) 3 A @24 VDC power-limited (+10, -15%)

Fuses

F1 (AC supervision) 250 VAC, 4A, 3 AG, slow blow
F2 (battery supervision) 32 VAC, 10 A, 3 AG, slow blow

Trouble supervision bus

J3 output Form A contact (open collector)
J4 input Form A contact (open collector)

Note: J3 and J4 can be interchanged.

Loss of AC Indication

Immediate indication (default)
8 hour delay (cut JP2)
16 hour delay (cut JP2 and JP3)

Size of APS-6R in enclosure

6.09 in. x 4.23 in. x 2.92 in.

J.2 Programming

Note: A control panel programmed for an AVPS-24/AVPS-24E/APS-6R cannot be used in a combination Fire/Burglary application, because the AVPS-24/AVPS-24E/APS-6R trouble input is the same input used to monitor the door tamper switch (STS-200).

The control panel must be programmed to supervise the AVPS-24/AVPS-24E or APS-6R. To program supervision for an AVPS-24/AVPS-24E or APS-6R, follow these steps:

1. Enter programming mode (refer to Section 3 “Programming”).
2. From the Program Change screen, select 7=SYSTEM (General System Functions) to display the System Function screen. Figure 82 shows a typical System Function screen.

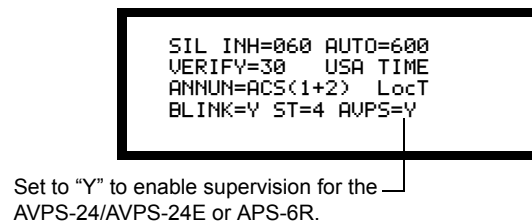

Figure 160 System Function Screen

3. Enter a “Y” after “AVPS=” as shown in Figure 82.
4. Press Enter to save changes; then, exit programming mode.

J.3 Supply Calculations

J.3.1 AVPS-24/AVPS-24E Calculations

Supply calculations for systems with an AVPS-24/AVPS-24E are as follows.

- Add 1.0 A for the AVPS-24 and 0.5 A for the AVPS-24E to the AC branch circuit current in Table 44 and Table 45.
- Do not include the load current on NAC circuits 3 and 4 in the 5.0 A limitation in Table 47 and notes.

System alarm current limitations with an AVPS-24/AVPS-24E installed follow:

- TB1, terminals 1 and 2 = 1.5 A
- TB1, terminals 3 and 4 = 0.5 A
- TB1, terminals 5 and 6 = 0.5 A
- TB1, terminals 3 and 4 combined with terminals 5 and 6 = 0.5 A
- All circuits on TB1 combined with TB2 terminals 1, 2, 3, and 4 = 5.0 A
- TB2, terminals 5, 6, 7 and 8 combined (NACs 3 and 4) = 3.0 A
- TB2, any one circuit = 2.5 A

J.3.2 APS-6R Calculations

Supply calculations for systems with an APS-6R follow:

- Add 2.5 A for the APS-6R and 1.2 A for the APS-6R to the AC branch circuit current in Table 44 and Table 45.
- Do not include the load current on NAC 3 and 4 in the 5.0 A limitation in Table 47 and notes.

System alarm current limitations with an APS-6R installed follow:

- TB2, terminal 1 and 2 or J1 = 3.0 A
- TB2, terminal 3 and 4 or J2 = 3.0 A
- TB2, terminals 1, 2, 3 and 4 combined = 6.0 A

J.4 Installation

This section contains instructions for installing an AVPS-24/AVPS-24E and an APS-6R.

J.4.1 Installing the AVPS-24/AVPS-24E

Mounting the AVPS-24/AVPS-24E

To mount the AVPS-24/AVPS-24E, follow these steps:

1. Place the AVPS-24/AVPS-24E into the cabinet as shown in Figure 161.
2. Insert mounting screws into cabinet; then tighten the screws until the AVPS-24/AVPS-24E is securely fastened to the cabinet.

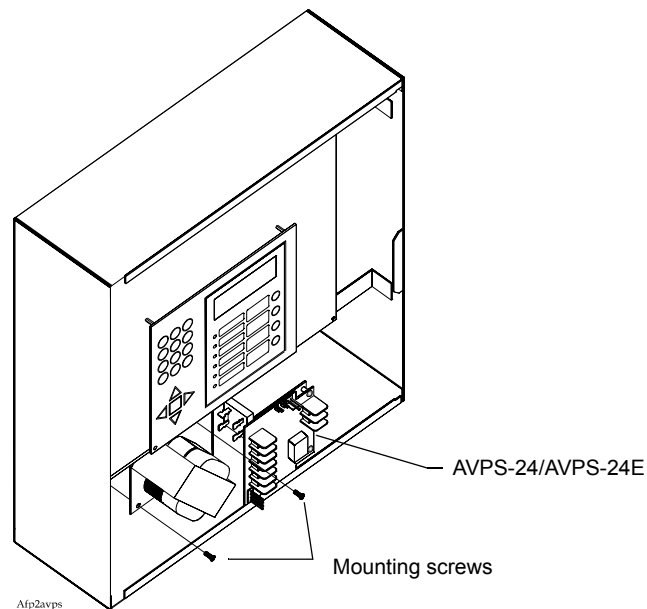

Figure 161 Mounting the AVPS-24/AVPS-24E

Wiring the AVPS-24/AVPS-24E

Wire the AVPS-24/AVPS-24E to the control panel according to the steps in Table 68 and the drawing in Figure 162.



WARNING: Use extreme caution when working with the AVPS-24 or APS-6R—high voltage and AC line-connected circuits are present in the AVPS-24 or APS-6R. Turn off and remove all power sources. To reduce the risk of electric shock—make sure to properly ground the AVPS-4R or APS-6R. Before connecting AC and DC power, install the APS-6R cover.

Step	Action												
1	<p>Connect AC power as follows</p> <table border="1"> <thead> <tr> <th>Wire and Color</th> <th>from AVPS-24/AVPS-24E</th> <th>to Control Panel</th> </tr> </thead> <tbody> <tr> <td>Earth Ground (green)</td> <td>TB1 terminal 6</td> <td>TB7 terminal 3</td> </tr> <tr> <td>AC Hot (black)</td> <td>TB1 terminal 5</td> <td>TB7 terminal 1</td> </tr> <tr> <td>AC Neutral (white)</td> <td>TB1 terminal 4</td> <td>TB7 terminal 2</td> </tr> </tbody> </table>	Wire and Color	from AVPS-24/AVPS-24E	to Control Panel	Earth Ground (green)	TB1 terminal 6	TB7 terminal 3	AC Hot (black)	TB1 terminal 5	TB7 terminal 1	AC Neutral (white)	TB1 terminal 4	TB7 terminal 2
Wire and Color	from AVPS-24/AVPS-24E	to Control Panel											
Earth Ground (green)	TB1 terminal 6	TB7 terminal 3											
AC Hot (black)	TB1 terminal 5	TB7 terminal 1											
AC Neutral (white)	TB1 terminal 4	TB7 terminal 2											
2	<p>Connect the battery as follows:</p> <table border="1"> <thead> <tr> <th>Wire and Color</th> <th>from AVPS-24/AVPS-24E</th> <th>to Control Panel</th> </tr> </thead> <tbody> <tr> <td>Battery – (black)</td> <td>TB1 terminal 3</td> <td>connector J3 (–)</td> </tr> <tr> <td>Battery + (red)</td> <td>TB1 terminal 2</td> <td>connector J3 (+)</td> </tr> </tbody> </table>	Wire and Color	from AVPS-24/AVPS-24E	to Control Panel	Battery – (black)	TB1 terminal 3	connector J3 (–)	Battery + (red)	TB1 terminal 2	connector J3 (+)			
Wire and Color	from AVPS-24/AVPS-24E	to Control Panel											
Battery – (black)	TB1 terminal 3	connector J3 (–)											
Battery + (red)	TB1 terminal 2	connector J3 (+)											
3	<p>Connect the Power Harness to control panel NACs 3 and 4 as follows:</p> <ul style="list-style-type: none"> • Cut jumpers JP6 and JP 7 on the CPU board (Figure 162). <p>Plug the Power Harness (PN 71093) into plug J10 on the CPU board (Figure 162) as follows:</p> <ul style="list-style-type: none"> • Connect J10 (–) to TB2 terminal 2 on the AVPS-24/AVPS-24E. • Connect J10 (+) to TB2 terminal 1 on the AVPS-24/AVPS-24E. 												
4	<p>Connect the Supervisory cable to the control panel as follows:</p> <ul style="list-style-type: none"> • Cut jumper JP3 on the CPU board (Figure 162) • Plug the gray Supervisory Cable (PN 71033) into J11 with the wires exiting the connector on top. Plug J11 is located in the bottom right center of the control panel circuit board. • Plug the other end of the Supervisory Cable into P1 on the AVPS-24 with the wires exiting from the bottom (Figure 162). 												

Table 68 AVPS-24/AVPS-24E Wiring Instructions

Figure 162 shows wiring connections between the AVPS-24/AVPS-24E and the control panel:

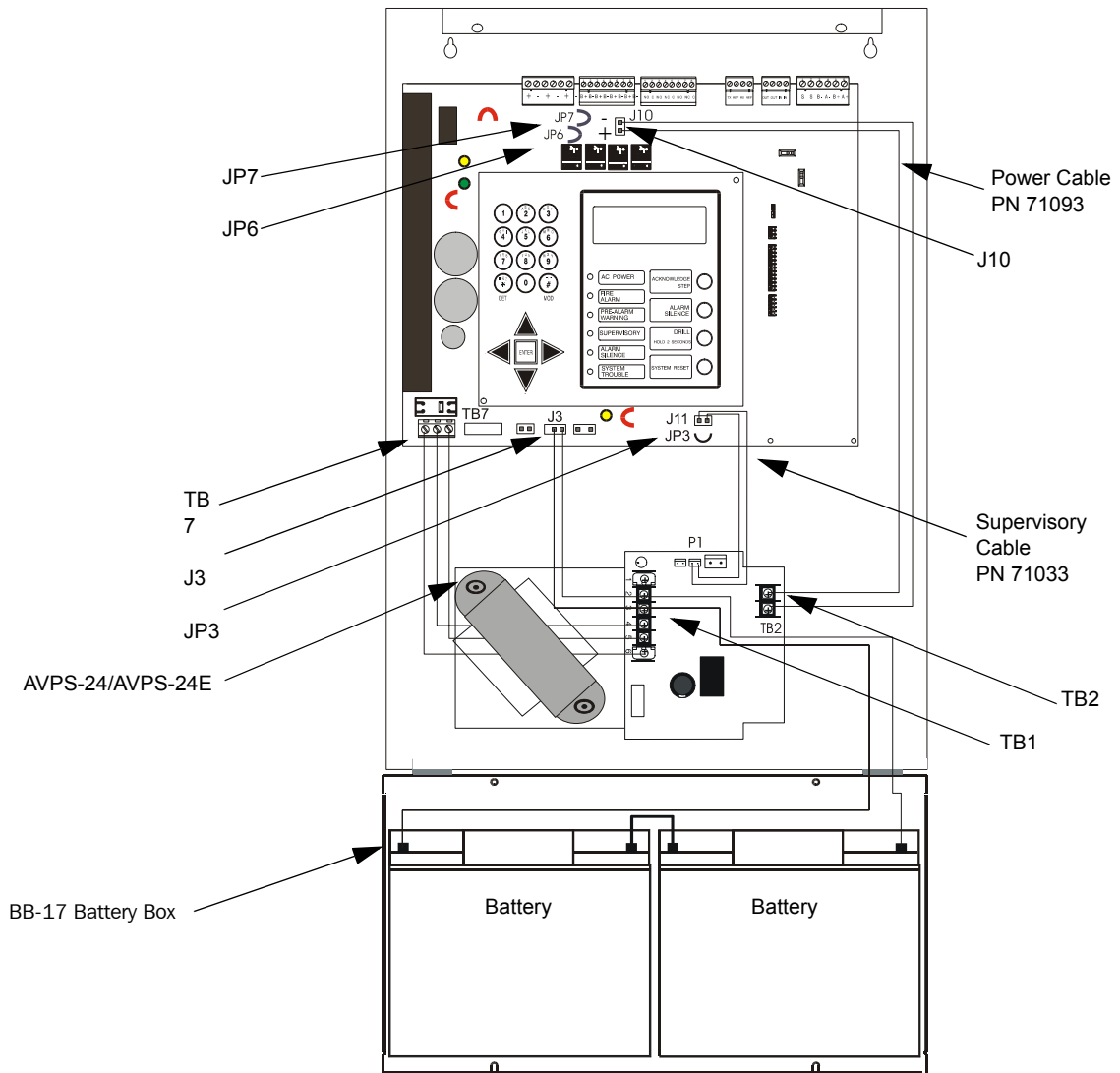

Figure 162 Wiring the AVPS-24 to the Control Panel

J.4.2 Installing the APS-6R

Mounting the APS-6R

To mount the APS-6R, follow these steps:

1. Place the APS-6R into the cabinet as shown in Figure 163.
2. Insert mounting screws into cabinet; then tighten the screws until the APS-6R is securely fastened to the cabinet.

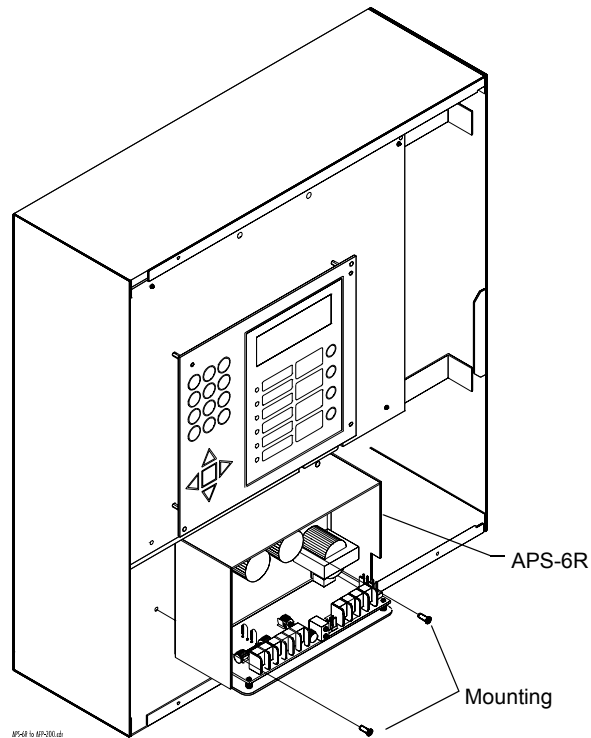

Figure 163 Mounting the APS-6R

Wiring the APS-6R

Wire the APS-6R to the control panel according to the steps in Table 69 and the drawing in Figure 164.



WARNING: Use extreme caution when working with the AVPS-24 or APS-6R—high voltage and AC line-connected circuits are present in the AVPS-24 or APS-6R. Turn off and remove all power sources. To reduce the risk of electric shock—make sure to properly ground the AVPS-4R or APS-6R. Before connecting AC and DC power, install the APS-6R cover.

Step	Action												
1	<p>Connect AC power:</p> <table border="1"> <thead> <tr> <th>Wire and Color</th> <th>from APS-6R...</th> <th>to Control Panel...</th> </tr> </thead> <tbody> <tr> <td>Earth Ground (green)</td> <td>TB1 terminal 3</td> <td>TB7 terminal 3</td> </tr> <tr> <td>AC Hot (black)</td> <td>TB1 terminal 1</td> <td>TB7 terminal 1</td> </tr> <tr> <td>AC Neutral (white)</td> <td>TB1 terminal 2</td> <td>TB7 terminal 2</td> </tr> </tbody> </table>	Wire and Color	from APS-6R...	to Control Panel...	Earth Ground (green)	TB1 terminal 3	TB7 terminal 3	AC Hot (black)	TB1 terminal 1	TB7 terminal 1	AC Neutral (white)	TB1 terminal 2	TB7 terminal 2
Wire and Color	from APS-6R...	to Control Panel...											
Earth Ground (green)	TB1 terminal 3	TB7 terminal 3											
AC Hot (black)	TB1 terminal 1	TB7 terminal 1											
AC Neutral (white)	TB1 terminal 2	TB7 terminal 2											
2	<p>Connect the battery:</p> <table border="1"> <thead> <tr> <th>Wire and Color</th> <th>from APS-6R...</th> <th>to Control Panel...</th> </tr> </thead> <tbody> <tr> <td>Battery – (black)</td> <td>TB3 terminal 2</td> <td>connector J3 (–)</td> </tr> <tr> <td>Battery + (red)</td> <td>TB3 terminal 1</td> <td>connector J3 (+)</td> </tr> </tbody> </table>	Wire and Color	from APS-6R...	to Control Panel...	Battery – (black)	TB3 terminal 2	connector J3 (–)	Battery + (red)	TB3 terminal 1	connector J3 (+)			
Wire and Color	from APS-6R...	to Control Panel...											
Battery – (black)	TB3 terminal 2	connector J3 (–)											
Battery + (red)	TB3 terminal 1	connector J3 (+)											
3	<p>Connect the Power Harness to control panel NACs 3 and 4 as follows:</p> <ul style="list-style-type: none"> • Cut jumpers JP6 and JP7 on the CPU board (Figure 164). <p>Plug the Power Harness (PN 71093) into plug J10 on the CPU board (Figure 164) as follows:</p> <ul style="list-style-type: none"> • Connect J10 (–) to TB2 terminal 2 on the APS-6R. • Connect J10 (+) to TB2 terminal 1 on the APS-6R. 												
4	<p>Connect the Supervisory cable to the control panel as follows:</p> <ul style="list-style-type: none"> • Cut jumper JP3 on the CPU board (Figure 164) • Plug the gray Supervisory Cable (PN 71033) into J11 on the CPU board (Figure 164) with the wires exiting the connector on top. • Plug the other end of the Supervisory Cable into J3 on the APS-6R (Figure 164). 												

Table 69 APS-6R Wiring Instructions

Figure 162 shows wiring connections between the APS-6R and the control panel:

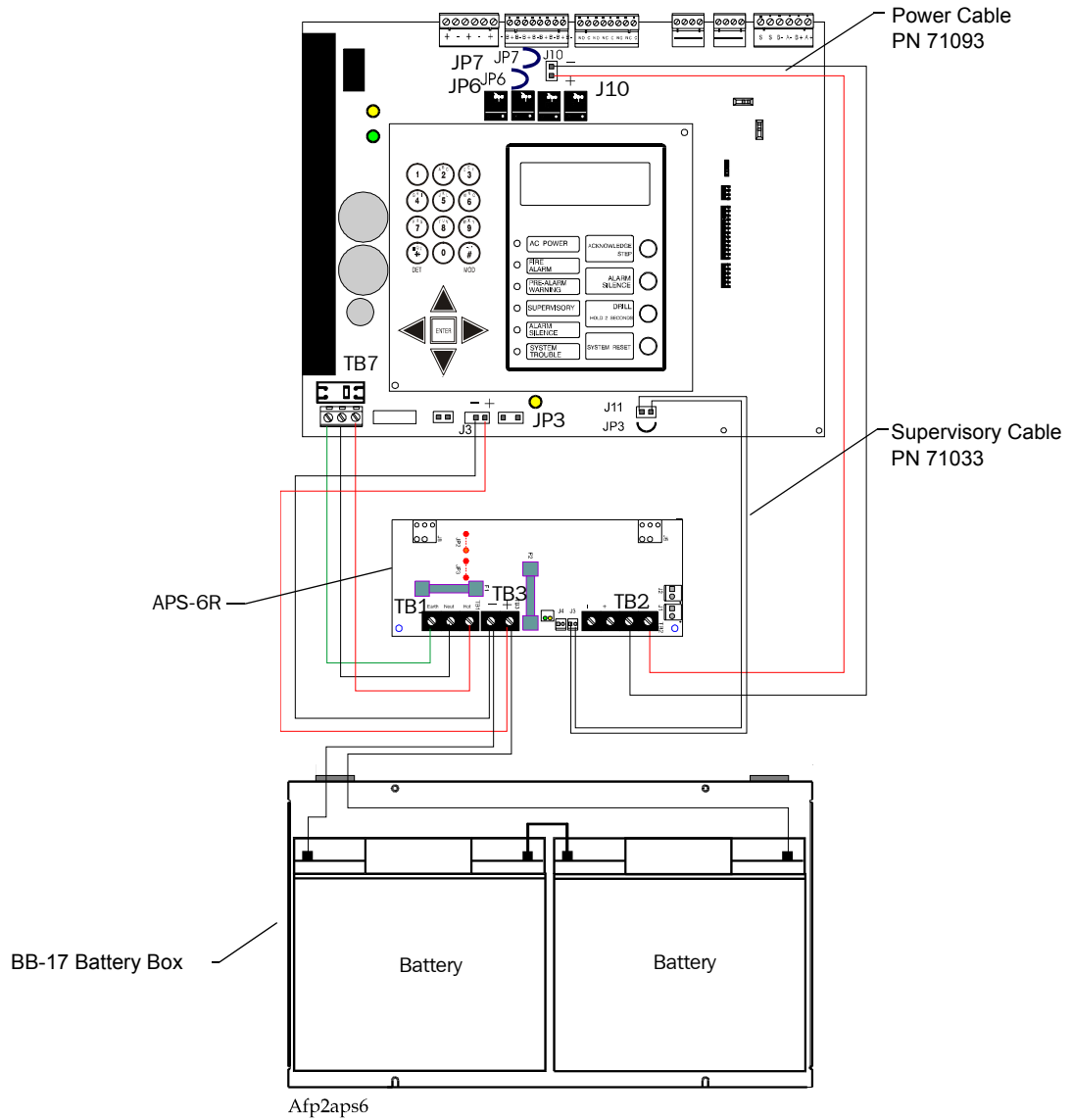

Figure 164 Wiring the APS-6R to the Control Panel

Appendix K UL Power-limited Wiring Requirements

K.1 Overview

This appendix provides guidelines for power-limited and nonpower-limited UL wiring requirements. Figure 165 shows typical wiring for a circuit with power-limited and nonpower-limited wiring that meets UL requirements, which are as follows:

- Power-limited and nonpower-limited circuit wiring must remain separated in the cabinet
- All power-limited circuit wiring must remain at least 0.25 inch (6.35 mm) away from any nonpower-limited circuit wiring.
- Power-limited and nonpower-limited circuit wiring cannot enter and exit the cabinet through the same knockout or conduits. Separate power-limited and nonpower-limited wiring as shown in Figure 165.

K.2 Typical Circuit with Nonpower-limited and Power-limited Wiring

Note: For complete information on wiring an RTM-8 module, refer to “Installing an RTM-8 Module” on page 63.

Figure 165 shows the RTM-8 module installed in the AFP-200 cabinet. Observe the following:

- Power-limited and nonpower-limited wiring maintain a minimum distance of 0.25 inch (6.35 mm) wire-to-wire.
- A 0.75 inch (19.05 mm) gap exists between relay 4 and relay 5. If using this module to drive both power-limited and nonpower-limited circuits, use relays 1-4 to drive power-limited circuits and relays 5-8 to drive nonpower-limited circuits. Using relays 5-8 for nonpower-limited circuits allows grouping them with the transmitter output nonpower-limited wiring.
- If using all relays as power-limited circuits, the 0.25 inch (6.35 mm) gap between relay 8 and the nonpower-limited transmitter output terminal meets UL power-limited wiring requirements.

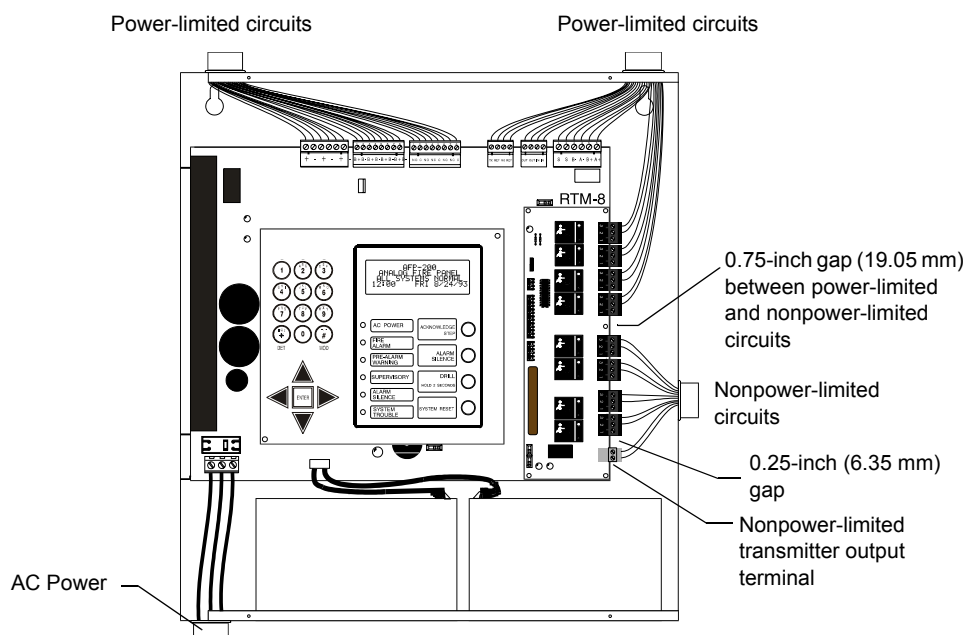

Figure 165 Typical Wiring Diagram for UL Power-limited Requirements

Appendix L U.S. Coast Guard & Lloyd's Register

USCG. Table 70 contains a list of equipment suitable for use in marine and shipyard applications as compatible with the AFP-200.

Notifier Equipment

29085 Ferrite Bead for I/O Lines
 29146 Ferrite Bead for AC input
 ABM-16AT Annunciator Blank Module
 ABM-32A Annunciator Blank Module
 ACM-16AT Annunciator Control Module
 ACM-32A Annunciator Control Module
 ACM-8R Annunciator Control Module (Relay)
 AEM-16AT Annunciator Expander Module
 AEM-32A Annunciator Expander Module
 AFM-16A Annunciator Fixed Module
 AFM-16AT Annunciator Fixed Module
 AFM-32A Annunciator Fixed Module
 AVPS-24 Audio/Visual Power Supply
 B224BI Intelligent isolator base
 B224RB Intelligent Relay base
 B401B Detector Base
 B402B Four-Wire Detector Base
 B501 Flangeless Base for Intelligent Detectors
 B501BH Sounder base with B501 base
 B501BH Sounder Base
 B501BHT Same as B501BH, but includes Temporal sounder
 B710LP Standard US Low-Profile base
 BGX-101L Addressable Manual Pull Station
 BX-501 Base for all Intelligent Detectors/Sensors
 CAB-AM Cabinet for Marine Applications
 CMX-1 Addressable Control Module
 CMX-2 Addressable Control Module
 CP-651 Ionization Detector
 CPX-551 Intelligent Ionization Smoke Detector
 CPX-751 Intelligent Ionization Smoke Detector
 CRT-2 Video Display Monitor with Keyboard
 DHX-501 Duct Housing
 DHX-502 Duct Housing
 Drip Shield Kit Alternate to CAB-AM
 FCM-1 Addressable Control Module
 FDX-551 Intelligent Thermal Sensor
 FMM-1 Addressable Monitor Module
 FMM-101 Addressable Mini Monitor Module
 FRM-1 Addressable Relay Module
 FSI-751 Addressable Low Profile Ion Detector
 FSP-751 Addressable Low Profile Photoelectric Detector
 FSP-751T Addressable Low Profile Photoelectric with Fixed thermal Detector
 FST-751R Addressable Low Profile Heat with Rate of Rise Sensor
 FZM-1 Addressable Zone Monitor Module
 HPX-751 Addressable Hostile-environment smoke detector
 ISO-X Loop Fault Isolator Module
 LCD-80 Liquid Crystal Display Module
 LDM-32 Lamp Driver Module
 LDM-E32 Lamp Driver Module
 LDM-R32 Lamp Driver Module
 LP-610 Smoke Detector Base

MMX-1 Addressable Monitor Module
 MMX-101 Addressable Mini Monitor Module
 MMX-2 Addressable Monitor Module
 N-ARA-10 Agent Release Pull Station
 NBG-12 Dull Action Manual Pull Station with Hex lock
 NBG-12L Dull Action Manual Pull Station with key lock
 NBG-12LX Addressable Pull Station
 NBG-12S Single Action Manual Pull Station with pigtail connections and hex lock
 NBG-12SP Same as NBG-12L with English and Spanish Labeling
 N-ELR Assortment Pack with Mounting Plate
 NIB-96 Network Interface Board
 NR45-24 Notifier Remote Battery Charger
 PRN-4 80-Column Printer
 R-120 120 ohm End-of-Line Resistor
 R-2.2K 2.2K End-of-Line Resistor
 R-27K 27K End-of-Line Resistor
 R-470K 470K End-of-Line Resistor
 R-47K 47K End-of-Line Resistor
 RTM-8 Relay Module
 SB-10 Surface Backbox
 SD-651 Photoelectric Detector
 SDX-551 Intelligent Photoelectric Detector
 SDX-751 Intelligent Photoelectric Detector
 SMB-500 Surface Mount Box
 WP-10 Weatherproof Backbox
System Sensor
 1400 Smoke Detector
 1451 Smoke Detector
 2400TH Smoke Detector with Thermal
 2451 Smoke Detector
 A2143-00 End-of-Line Resistor Assembly
 A77-16B End-of-Line Power Supervision Relay
 H24 (W) 24VDC Horn Red (White)
 H24K 24VDC Horn weather proof Red only
 MA-24 Electronic Sounder, 24 VDC
 MA-24D Sounder, 24 VDC
 MASS24110ADA 24 VDC Sounder/Strobe 110 CD
 MASS241575ADA 24 VDC Sounder/Strobe 15/75 CD
 MASS2415ADA 24 VDC Sounder/Strobe 15 CD
 MASS2475ADA 24 VDC Sounder/Strobe 15/75 CD
 MASS24LO 24V Red Sounder/Strobe
 MASS24LOC 24V Sounder/Strobe Ceiling
 P24110 w) 24VDC 110cd Horn / Strobe Red (White)
 P24110K 24VDC 110cd Horn / Strobe weather proof Red only
 P2415 (W) 24VDC 15cd Horn / Strobe Red (White)
 P241575 (W) 24VDC 15 / 75cd Horn / Strobe

Red (White)
 P241575AG 24VDC 15 / 75cd Horn / Strobe agent Red only
 P241575EV 24VDC 15 / 75cd Horn / Strobe evacuation Red only
 P241575K 24VDC 15 / 75cd Horn / Strobe weather proof Red only
 P241575P (W) 24VDC 15 / 75cd Horn / Strobe no lettering Red (White)
 P2430 (W) 24VDC 30cd Horn / Strobe Red (White)
 P2475 (W) 24VDC 75cd Horn / Strobe Red (White)
 P2475K 24VDC 75cd Horn / Strobe weather proof Red only
 PS24LO 24V Red Sounder Strobe
 RA-400/RA400Z Remote LED Assembly
 S24110 w) 24VDC 110cd Strobe Red (White)
 S24110K 24VDC 110cd Strobe weather proof Red only
 S2415 (W) 24VDC 15cd Strobe Red (White)
 S241575 (W) 24VDC 15 / 75cd Strobe Red (White)
 S241575AG 24VDC 15 / 75cd Strobe agent Red only
 S241575EV 24VDC 15 / 75cd Strobe evacuation Red only
 S241575K 24VDC 15 / 75cd Strobe weather proof Red only
 S241575P (W) 24VDC 15 / 75cd Strobe no lettering Red (White)
 S2430 (W) 24VDC 30cd Strobe Red (White)
 S2475 (W) 24VDC 75cd Strobe Red (White)
 S2475K 24VDC 75cd Strobe weather proof Red only
 SS-24 Strobe 24 VDC
 SS24110ADA 24 VDC Sounder/Strobe 110 CD
 SS241575ADA 24 VDC Sounder/Strobe 15/75 CD
 SS2415ADA 24 VDC Sounder/Strobe 15 CD
 SS2475ADA 24 VDC Sounder/Sounder 75 CD
 SS24LO 24 V Red Sounder Strobe
 SS24LOC 24V Sounder/Strobe Ceiling
 WBB Weatherproof Backbox
Hochiki
 HSC-200 Detector Base
 HSC-4R Four-Wire Detector Base
 SIH-24F Smoke Detector
 SLK-24F Smoke Detector
Wheelock
 7002T-24 Horn with Strobe, 24 VDC
 MB-G10-24-R Bell 10" Gong 24 VDC Red
 MB-G6-24-R Bell 6" Gong 24 VDC Red
Fenwal
 27121-0 140 Degree F. Thermal Detector
 27121-0 190 Degree F. Thermal Detector
 27121-0 225 Degree F. Thermal Detector

Table 70 Equipment Suitable for Marine Applications: US Coast Guard

Table 71 contains a list of equipment listed with Lloyd's Register as compatible with the AFP-200.

Notifier Equipment

29085 Ferrite Bead for I/O Lines
 29146 Ferrite Bead for AC input
 ABM-16AT Annunciator Blank Module
 ABM-32A Annunciator Module Blank
 ACM-16AT Annunciator Control Module
 ACM-32A Annunciator Control Module
 ADP-4 Annunciator Dress Panel
 AEM-16AT Annunciator Expander Module
 AEM-32A Annunciator Expander Module
 AVPS-24 Audio/Visual Power Supply
 B224BI Intelligent isolator base
 B224RB Intelligent Relay base
 B501 Flangeless Base
 B501BH Sounder base with B501 base
 B501BHT Same as B501BH, but includes Temporal sounder
 B710LP Standard US Low-Profile base
 BGX-101L Addressable Manual Pull Station
 BP-3 Battery Dress Panel
 CAB-AM Cabinet for Marine Applications
 CMX-1 Addressable Control Module
 CMX-2 Addressable Control Module
 CPX-551 Intelligent Ionization Smoke Detector
 CPX-751 Intelligent Ionization Smoke Detector
 FCM-1 Addressable Control Module
 FDX-551 Intelligent Thermal Sensor
 FMM-1 Addressable Monitor Module
 FMM-101 Addressable Mini Monitor Module
 FRM-1 Addressable Relay Module
 FSI-751 Addressable Low Profile Ion Detector
 FSP-751 Addressable Low Profile Photoelectric Detector
 FSP-751T Addressable Low Profile Photoelectric with Fixed thermal Detector
 FST-751R Addressable Low Profile Heat with Rate of Rise Sensor
 FZM-1 Addressable Zone Monitor Module

HPX-751 Addressable Hostile-environment smoke detector
 ISO-X Loop Fault Isolator Module
 LCD-80 Liquid Crystal Display Module
 MMX-1 Addressable Monitor Module
 MMX-2 Addressable Monitor Module
 NBG-12 Dull Action Manual Pull Station with Hex lock
 NBG-12L Dull Action Manual Pull Station with key lock
 NBG-12LX Addressable Pull Station
 NBG-12S Single Action Manual Pull Station with pigtail connections and hex lock
 NBG-12SP Same as NBG-12L with English and Spanish Labeling
 NIB-96 Network Interface Board
 PS-12250 Battery 12-volt, 25 amp-hour
 R-120 120 Ohm End-of-Line Resistor
 R-2.2K 2.2K End-of-Line Resistor
 R-27K 27K End-of-Line Resistor
 R-470K 470K End-of-Line Resistor
 R-47K 47K End-of-Line Resistor
 SB-10 Surface Backbox
 SDX-551 Intelligent Photoelectric Detector
 SDX-751 Intelligent Photoelectric Detector
 SMB-500 Surface Mount Box
 WP-10 Weatherproof Backbox

System Sensor

H24 (W) 24VDC Horn Red (White)
 H24K 24VDC Horn weather proof Red only
 MA/SS-24D Electronic Sounder/Strobe, 24 VDC
 P24110 (w) 24VDC 110cd Horn / Strobe Red (White)
 P24110K 24VDC 110cd Horn / Strobe weather proof Red only
 P2415 (W) 24VDC 15cd Horn / Strobe Red

(White)
 P241575 (W) 24VDC 15 / 75cd Horn / Strobe Red (White)
 P241575AG 24VDC 15 / 75cd Horn / Strobe agent Red only
 P241575EV 24VDC 15 / 75cd Horn / Strobe evacuation Red only
 P241575K 24VDC 15 / 75cd Horn / Strobe weather proof Red only
 P241575P (W) 24VDC 15 / 75cd Horn / Strobe no lettering Red (White)
 P2430 (W) 24VDC 30cd Horn / Strobe Red (White)
 P2475 (W) 24VDC 75cd Horn / Strobe Red (White)
 P2475K 24VDC 75cd Horn / Strobe weather proof Red only
 S24110 (w) 24VDC 110cd Strobe Red (White)
 S24110K 24VDC 110cd Strobe weather proof Red only
 S2415 (W) 24VDC 15cd Strobe Red (White)
 S241575 (W) 24VDC 15 / 75cd Strobe Red (White)
 S241575AG 24VDC 15 / 75cd Strobe agent Red only
 S241575EV 24VDC 15 / 75cd Strobe evacuation Red only
 S241575K 24VDC 15 / 75cd Strobe weather proof Red only
 S241575P (W) 24VDC 15 / 75cd Strobe no lettering Red (White)
 S2430 (W) 24VDC 30cd Strobe Red (White)
 S2475 (W) 24VDC 75cd Strobe Red (White)
 S2475K 24VDC 75cd Strobe weather proof Red only
 WBB Weatherproof Backbox

Table 71 Equipment Suitable for Marine Applications: Lloyd's Register

Appendix M CBE Programming

M.1 Purpose

Control-By-Event (CBE) is a programming method that lets you provide a variety of response based on various combinations of initiating events. CBE controls the interaction among the alarm initiating devices, software zones, and alarm notification appliances. Each addressable, intelligent detector monitor module, and control module contains an area for 1–5 CBE entries. For example, Figure 166 shows a sample programming screen that shows CBE entries for a module.



Figure 166 Sample Programming Screen with CBE Entries

M.2 Software Zones

A software zone is a software group in control panel memory. The control panel provides 99 software zones that you can use for CBE programming, and they are:

- Zone 00 (general alarm zone)
- Software zones (01-89)
- Special function zones (90, 95, 96, 97, 98, 99)
- Releasing zones (91–94)

Each input (detector and monitor) can be mapped to software zones 01-89, releasing zones 91-94, and time control zones (96 and 97). Each output (control module) can be mapped to all software zones 00-99.

M.3 How to Program CBE

You program CBE by programming input and output devices with a list of zones. You do this by editing devices in autoprogram (“How to Autoprogram the Control Panel (1=auto)” on page 73) or in point programming (“How to Edit or Delete a Point (2=point)” on page 78). The Autoprogram option creates a default CBE list, depending on the type of device. This section provides three examples of CBE programming.

M.3.1 CBE Example 1

Program a photoelectric detector (D01), to activate a control module (M08), when detector D01 goes into alarm. Edit the detector and module so they both list zone Z05,

which puts Z05 into the CBE of D01 and M08. When detector D01 goes into alarm, control module M08—and all devices and zones mapped to M08—also activate.

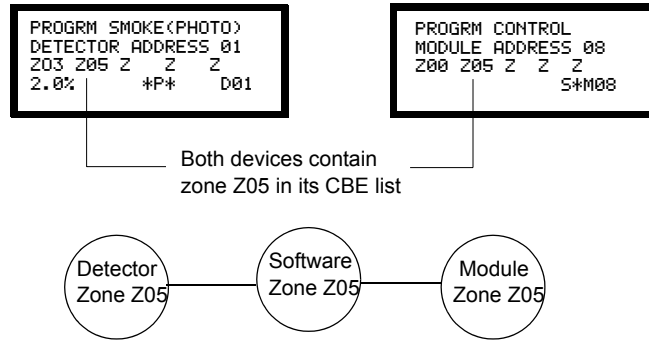

Figure 167 CBE Example 1

M.3.2 CBE Example 2

Program a Bell Circuit (B04) to activate a march time code.

1. Program Z98 (Code Type) to “March Time.” For instructions, refer to Section 3 “Programming”.
2. Program the Bell Circuit B04 to list Z98 in its CBE list.
3. When the Bell Circuit B04 activates, all devices connected to B04 will pulse with the March Time code.

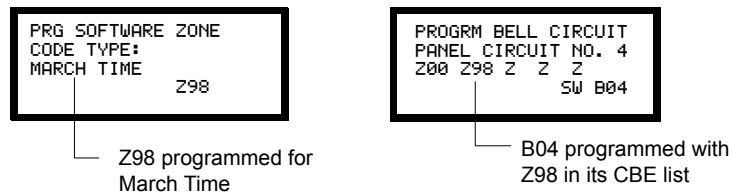

Figure 168 CBE Example 2

Appendix N External Battery Charger

N.1 Overview

The CHG-120 is capable of charging 25 AH to 120 AH batteries. You must install an external battery charger if the power supply must deliver more than 3.0 A of current when no fire alarm signal is present. To use the CHG-120 with the AFP-200, you must cut jumper JP2 on the main CPU board (see Figure 3 on page 17).

Refer to the CHG-120 Instruction Manual (PN 50641) for detailed information on CHG-120 specifications, connections, operation, and configuration.

N.2 Installation Requirements

Options for mounting batteries are as follows:

1. Cut jumper JP2 on the main circuit board.
2. Mount the CHG-120 in an external battery box
3. Locate the CHG-120 within 20 feet (6.096 m) of the control panel.

The CHG-120 battery charger is designed to charge lead-acid batteries that provide emergency standby power for a Fire Alarm Control Panel (FACP). Two 12-volt batteries are always used in series to supply 24 VDC nominal.

N.3 Mounting the CHG-120

N.3.1 Mounting the Charger into a CAB-X3 Series Cabinet

You can mount a charger into the bottom row of a CAB-X3 Series Cabinet, as long as the charger is within 20 feet (6.096 m) of the load. Typically, a charger mounts into the lower right corner of the CAB-X3—beside the power supply (Figure 169, position 2). If using an additional CAB-X3, you can mount the charger in the lower left corner (Figure 169, position 2).

Figure 169 shows the two mounting positions of a charger into a CAB-X3.

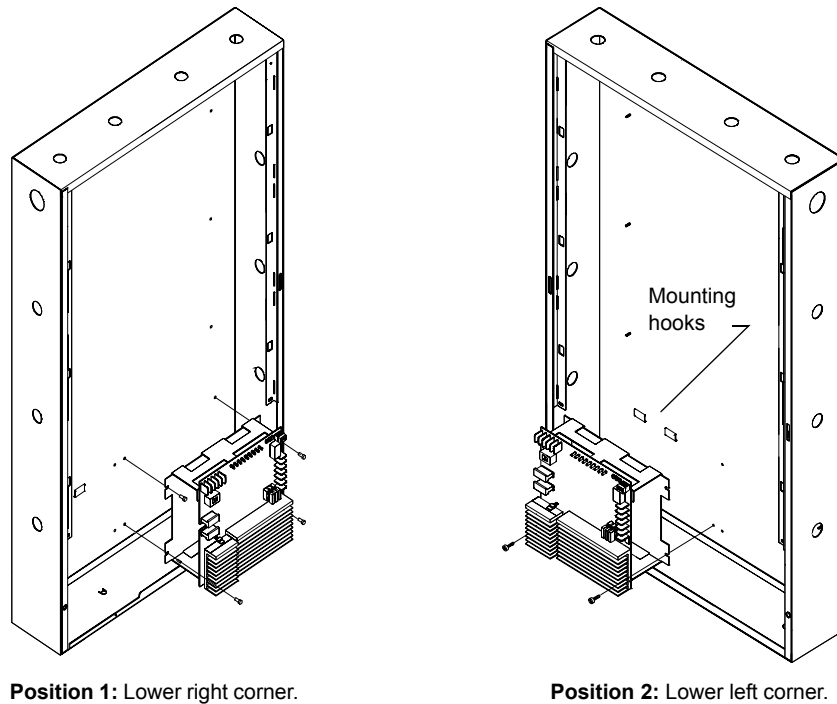
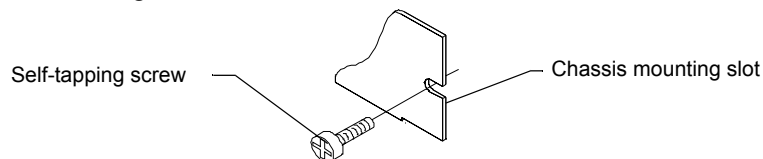

Figure 169 Mounting a Charger into a CAB-X3 (CAB-C3 shown)

To mount a charger into a CAB-X3 Series Cabinet, follow these instructions:

1. Place the charger chassis mounting slots in line with the mounting holes in the cabinet. If mounting in position 2, place the charger chassis onto the mounting hooks in the cabinet.
2. Insert the self-tapping screws through the charger chassis mounting slots and into the mounting holes in the cabinet.



3. Tighten the self-tapping screws.

N.3.2 Mounting the Charger into a Battery Box

You can also mount a charger into a BB-55 or NFS-LBB battery box, as long as the box is within 20 feet (6.096 m) of the load. Note that a charger takes up half the space of the

battery box. This means there is only room left for two 25 AH batteries in the BB-55 or NFS-LBB. Figure 170 shows the mounting position.

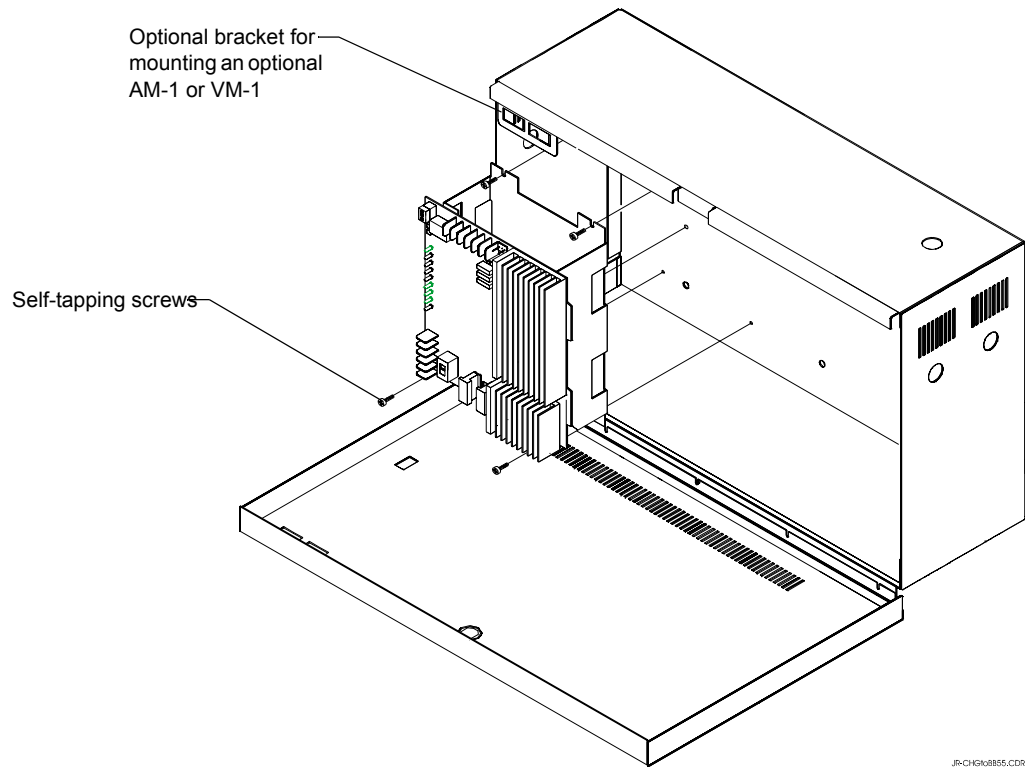
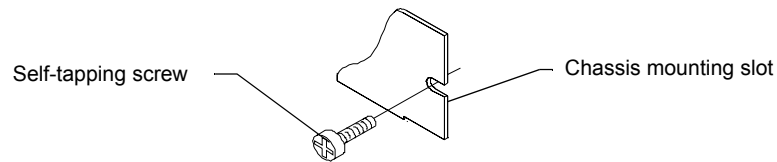

Figure 170 Mounting a Charger into a BB-55 or NFS-LBB

To mount a charger into the battery box, follow these instructions:

1. Place the charger chassis mounting slots in line with the mounting holes in the BB-55 or NFS-LBB.
2. Insert the self-tapping screws through the charger chassis mounting slots and into the mounting holes in the battery box.



3. Tighten the self-tapping screws.

N.4 Connecting the CHG-120

Figure 171 shows how to connect four 55 AH batteries to the charger:

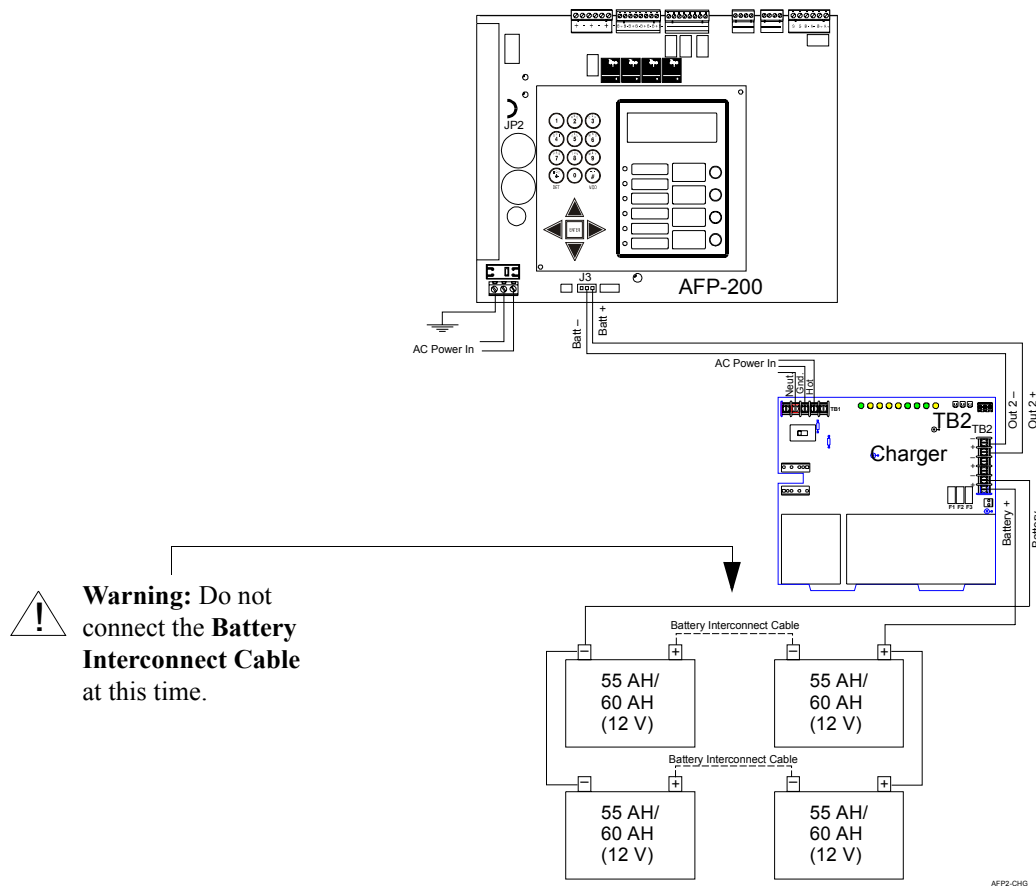

Figure 171 Connecting the CHG-120 to the AFP-200

N.4.1 Connecting a CHG-120 to the AFP-200

Connect CHG-120 (tied to four batteries) to the AFP-200 as follows:

1. Remove all power sources to the charger.
2. Tie the batteries in pairs by connecting the battery negative terminals and the battery positive terminals as shown in Figure 171.
3. Connect the battery negative cable to the TB2 terminal (on the charger labeled "Battery -") as shown in Figure 171.
4. Connect the battery positive cable to the TB2 terminal (on the charger) labeled "Battery +" as shown in Figure 171.
5. Proceed to the section "Connecting the Charger." **Do not connect the Battery Interconnect Cable at this time**—refer to the CHG-120 manual, part number 50641 for more detail.

Limited Warranty

NOTIFIER® warrants its products to be free from defects in materials and workmanship for eighteen (18) months from the date of manufacture, under normal use and service. Products are date stamped at time of manufacture. The sole and exclusive obligation of **NOTIFIER®** is to repair or replace, at its option, free of charge for parts and labor, any part which is defective in materials or workmanship under normal use and service. For products not under **NOTIFIER®** manufacturing date-stamp control, the warranty is eighteen (18) months from date of original purchase by **NOTIFIER®**'s distributor unless the installation instructions or catalog sets forth a shorter period, in which case the shorter period shall apply. This warranty is void if the product is altered, repaired or serviced by anyone other than **NOTIFIER®** or its authorized distributors or if there is a failure to maintain the products and systems in which they operate in a proper and workable manner. In case of defect, secure a Return Material Authorization form from our customer service department. Return product, transportation prepaid, to **NOTIFIER®**, 12 Clintonville Road, Northford, Connecticut 06472-1653.

This writing constitutes the only warranty made by **NOTIFIER®** with respect to its products. **NOTIFIER®** does not represent that its products will prevent any loss by fire or otherwise, or that its products will in all cases provide the protection for which they are installed or intended. Buyer acknowledges that **NOTIFIER®** is not an insurer and assumes no risk for loss or damages or the cost of any inconvenience, transportation, damage, misuse, abuse, accident or similar incident.

NOTIFIER® GIVES NO WARRANTY, EXPRESSED OR IMPLIED, OF MERCHANTABILITY, FITNESS FOR ANY PARTICULAR PURPOSE, OR OTHERWISE WHICH EXTEND BEYOND THE DESCRIPTION ON THE FACE HEREOF. UNDER NO CIRCUMSTANCES SHALL **NOTIFIER®** BE LIABLE FOR ANY LOSS OF OR DAMAGE TO PROPERTY, DIRECT, INCIDENTAL OR CONSEQUENTIAL, ARISING OUT OF THE USE OF, OR INABILITY TO USE **NOTIFIER®** PRODUCTS. FURTHERMORE, **NOTIFIER®** SHALL NOT BE LIABLE FOR ANY PERSONAL INJURY OR DEATH WHICH MAY ARISE IN THE COURSE OF, OR AS A RESULT OF, PERSONAL, COMMERCIAL OR INDUSTRIAL USE OF ITS PRODUCTS.

This warranty replaces all previous warranties and is the only warranty made by **NOTIFIER®**. No increase or alteration, written or verbal, of the obligation of this warranty is authorized.

"**NOTIFIER**" is a registered trademark.



World Headquarters
12 Clintonville Road
Northford, CT 06472-1653 USA
203-484-7161
fax 203-484-7118

www.notifier.com

NOTIFIER is a **Honeywell** company.

