

# R A D I O N I C S

6112:MAIN

---

## Program Entry Guide

For the D6112 Control/Communicator

## Notice

---

The material and instructions covered in this manual have been carefully checked for accuracy and are presumed to be reliable. However, Radionics, Inc. assumes no responsibility for inaccuracies and reserves the right to modify and revise this manual without notice.

It is our goal at Radionics to always supply accurate and reliable documentation. If a discrepancy is found in this documentation, please mail a photocopy of the corrected material to:

Radionics, Inc.  
 c/o Technical Writing Department  
 1800 Abbott Street  
 Salinas, California 93901

## Table of Contents

---

SECTION	PAGE
i. Introduction	2
ii. Equipment and Literature Requirements _____	2
iii. How to Edit the Program File _____	2
1. Globals Module: Central Station Report Codes _____	3
2. PriPhone Module: Primary Phone Number and Transmitting Format _____	5
3. AltPhone Modules: Alternate Phone Number and Transmitting Format Routing Codes _____	5
4. Devices Module: Command Center Characteristics _____	8
5. Command Keys Module: COMMAND Key Functions _____	10
6. Combinations Module: Command Center Arm/Disarm Combinations _____	13
7. Account #1 Module _____	14
8. Account #2 Module _____	14
9. Test Timer Module: Automatic Test Report Parameters _____	18
10. Zone Code Index _____	19
11. Recommended Zone Codes _____	24
12. Typical System Configurations _____	25
13. System Trouble Report Codes _____	29

## I. Introduction

The Radionics D6112 integrated Control/Communicator has eight supervised hardwire protective zones: six standard programmable zones, one zone optimized for smoke detectors, and one zone optimized for glass-break detectors (both fully programmable). The D620, D626, D630, and D636 Command Centers are available for arming and disarming the D6112 security system. The D620, and D630 Command Centers can annunciate up to eight protective zones, and the D626, and D636 Command Center can annunciate up to 16 protective zones. The D630 and D636 can provide three additional hardwire protective zones, as well as performing command center functions (for specifications and installation procedures for the D636 Command Center, refer to the *D636 Installation Instructions #74-05475-000*). The D640 Zone Expansion Center can provide six additional zones. A D6112 security system can support as many as four command centers and/or zone expansion devices, which interface to the D6112 through a four-conductor cable.

## ii. Equipment and Literature Requirements

To program the D6112 Control/Communicator, you need:

- the Radionics D5100 Bar Code Programmer, equipped with the
- **Omegawand 2.1** operating system software and the
- 6112:MAIN product handler
- OPTIONAL: The D6112 can also be programmed with the D9310 Remote Account Manager

Before installing a D6112 security system, read:

- the *D5100 Bar Code Programmer Operation Manual*
- the *D6112 Control/Communicator Operation and Installation Manual*
- the *6112:MAIN Program Entry Guide*

## iii. How to Edit the Program File

Each D6112 Control/Communicator programming option (Program Item) is listed with a *Display* and a *Default* (as they appear in the Programmer display), a set of *Selections*, and a *Description*. A typical Program Item is shown below. The **Selections** (Yes or No) are the only entries available for a particular Program Item. *Do not use unlisted entries*. Words in the description which have been printed in **bold face** are descriptive buzz words which are used in the Program Item prompt.

Display & Default	Selections	Description
1.9 BzPhFail    Yes	Yes or No	Pulse <b>buzzer</b> for <b>failure</b> to report to central station after ten attempts on the <b>phone</b> line.

NOTE: The D6112 Control/Communicator is shipped with a program which has been loaded for your convenience. Some of the defaults in the program differ from the standard defaults of the 6112:MAIN product handler.

### Program Modules

The Program Items in the D6112:MAIN Product Handler are grouped in *modules*. To access a module with the Programmer, ADVANCE the Programmer display until the desired module title is shown. Scan the ENTER bar code to show the first Program Item of that module. If a particular module is not required for your application, that module may be bypassed by scanning the ADVANCE bar code when its title is displayed. Once a program module has been ENTERed, the Program Items of that module can be edited. After *all* the Program Items of that module have been edited, the Programmer returns to the first Program Item of that module. When the EXIT bar code is scanned, the Programmer advances to the next program module title. NOTE: A module can be EXITed from any point within the module. To escape the D6112:MAIN Handler, scan the EXIT bar code until the Programmer displays **OmegaWand 2.1**.

## 1. Globals Module: Central Station Report Codes, Remote Programming, and AUX Relay Programming

The Program Items listed in this module are used to select central station report codes, select the D6112 bell output time, and enable the D6112 buzzer for certain system failures. This module should not be bypassed without checking the default settings to ensure proper programming for your application.

Display	Default	Selections	Description
1 Globals		ENTER or ADVANCE	Scan the ENTER bar code to access this module. Scan the ADVANCE bar code to bypass this module.
1.1 Tbl		0 through 9 B through F Blank	<b>Trouble</b> report code. For Radionics Receivers enter F. Blank Entry = no trouble report.
1.2 Res		0 through 9 B through F Blank	<b>Restoral</b> report code. For Radionics Receivers enter E. Blank Entry = no restoral report.
1.3 Open		0 through 9 B through F Blank	<b>Opening</b> report code. For Radionics Receivers enter B. Blank Entry = no opening report.
1.4 Close		0 through 9 B through F Blank	<b>Closing</b> report code. For Radionics Receivers enter C. Blank Entry = no closing report.
1.5 Cancel		0 through 9 B through F Blank	<b>Cancel</b> report code. For Radionics Receivers enter D. Blank Entry = no cancel report.
NOTE: If Radionics BFSK superfast single round or Modem II central station formats are programmed, Program Items 1.1 Tbl and 1.2 Res will default to the standard Radionics Receiver report code (i.e. 1.1 Tbl F).			
1.6 Duress		0 through 9 B through F Blank	<b>Duress</b> report code. Blank Entry = no duress report. For Radionics D6000 or D6500 Receivers operating in the D6000 format, do not use entries B through F. B through F can only be used with the Modem II format.
1.7 BatSupv	9	0 through 9 B through F Blank	<b>Battery supervision</b> report code. For Radionics Receivers enter 9. Blank entry = no low battery reports. If a "9" is entered, battery supervision reports are transmitted as Trouble Zone 9 and Restoral Zone 9.
1.8 Bell	0	0 through 63	Alarm bell output time in minutes. Time restarts with each new alarm tripped. "0" entry = no bell output. The minimum bell time required for U.L. certificated applications is 4 minutes.
1.9 BzPhFail	Yes	Yes or No	Pulse <b>buzzer</b> for <b>failure</b> to report to central station after ten attempts on the <b>phone</b> line, or if the RJ38X jack is unplugged.
1.10 BzACFail	No	Yes or No	Pulse <b>buzzer</b> for <b>AC power failure</b> . If this program item is Yes, a test report (if programmed in Module #9 Test Timer) will be transmitted to the central station when the AC power is restored.
1.11 DTMF	No	Yes or No	Enter Yes to enable <b>Dual Tone Multi-Frequency</b> dialing of the telephone numbers. Enter No for pulse dialing.

Display	Default	Selections	Description
1.12 CsPrg	No	Yes or No	Enter Yes to enable remote programming of the D6112 initiated from a <b>central station</b> . (If Yes is entered, enter a passcode in 1.14 Pass.)
1.13 Cmd43	No	Yes or No	Permit remote programming initiated from the account premises by entering <b>COMMAND 4 3</b> at a command center. (If Yes is entered, set 1.12 CsPrg to Yes, and enter a passcode in 1.14 Pass.)
1.14 Pass		0 through 9 B through F Blank	Remote programming security <b>passcode</b> . A four character entry is required. Blank Entry = no remote programming.
1.15 AnsArm	0	0 through 14 Blank	Set telephone ring counter to <b>answer</b> when either Account #1 or Account #2 is <b>master armed</b> . Blank or 0 = no answer.
1.16 AnsDis	0	0 through 14 Blank	Set telephone ring counter to <b>answer</b> when both Account #1 and Account #2 are <b>not master armed</b> . Blank or 0 = no answer.

## NOTES:

- 1) If one account is armed and one account is disarmed, the ring counter tracks rings on the *armed* account.
- 2) If either account is perimeter armed, the ring counter will follow the the entry in 1.16 AnsDis.
- 3) The actual number of rings may differ from the number of rings entered in 1.15 AnsArm and 1.16 AnsDis if the first ring is short or if ring counting has occurred within the past 5 minutes.

1.17 AuxRlyTm	2	2, 5, 10, 15	<b>Auxiliary relay</b> contact closure time, when activated. Select the time, in seconds, of contact closure. Use only the entries listed (2, 5, 10, 15). Other entries will round off to the next highest valid entry.
---------------	---	--------------	-------------------------------------------------------------------------------------------------------------------------------------------------------------------------------------------------------------------------

If a passcode is programmed, but not assigned to either account, entering the passcode activates the auxiliary relay. (See 6.4 C1Acct1 and 6.5 C1Acct2 in the Combinations section). If the auxiliary relay is programmed to activate upon a zone alarm, the activation time will follow the programmed bell time (see Zone Code Digit Three). The auxiliary relay can be activated by either the passcode or a zone alarm if both are programmed.

## 2. PriPhone Module: Primary Phone Number and Transmitting Format

### 3. AltPhone Module: Alternate Phone Number and Transmitting Format

#### Routing Codes

If the D6112 Control/Communicator is installed in a non-reporting (local) system, the PriPhone and AltPhone modules may be bypassed. If the communicator reports to only one Receiver, the AltPhone module may be bypassed.

Before a D6112 Control/Communicator can report to a central station, it must be programmed with a telephone number and a transmitting format. This section of the Program Entry Guide describes the parameters for the Primary telephone number (module 2), usually associated with the primary central station receiver, and the Alternate telephone number (module 3), usually associated with the alternate central station receiver.

When more than one telephone number is used by the D6112 to transmit reports, the control/communicator may be programmed with a process for distributing the reports between the Primary and Alternate telephone numbers. This process is called *call routing*. Many combinations of call routing are available for the D6112. See the Routing Table on the following page for specific details.

After programming the Primary Telephone module, stroke the EXIT bar code, and then ENTER the AltPhone module.

Display	Default	Selections	Description
2 PriPhone		ENTER or ADVANCE	Scan the ENTER bar code to access this module. Scan the ADVANCE bar code to bypass this module.
3 AltPhone			
2.1 P		0 through 9 C or D Blank	Telephone number <b>prefix</b> for the primary/alternate central station receiver. Enter up to eight characters. C = 3 second pause. D = 7 second dial tone wait. Blank Entry = No prefix/area code. NOTE: A delay of 7 seconds is automatically inserted in front of the prefix.
3.1 AP			
2.2 Ph		0 through 9 Blank	<b>Telephone</b> number for the primary/alternate central station receiver. Enter up to seven digits. Blank Entry = No telephone number.
3.2 APh			
2.3 Modem	No	Yes or No	Enter Yes to enable optional <b>Modem II</b> format. Modem II format is compatible with the Radionics D6500 Receiver programmed in the Modem II format. When Modem II format is enabled, other central station formats are not functional, and 2.5 Ack14, 3.5 AAck14, 2.7 Ack23, and 3.11 AAck23 must be No.
3.3 AModem	No		
2.4 CS	6	1 through 6 Blank	Primary/alternate <b>central station</b> format is: (6) Radionics BFSK superfast single round (5) Radionics single round with parity digit. (Reverts to double round after 2 single round attempts for each call.) (4) Ademco high speed double round (3) Silent Knight high speed double round (2) Ademco low speed double round (1) Silent Knight low speed double round (Blank Entry) Sescoa, Franklin high speed double round NOTE: If two accounts are programmed, either BFSK or Modem II format must be used.
3.4 ACS	6		

Display	Default	Selections	Description
2.5 Ack14	No	Yes or No	Accept a 1400 Hz acknowledgement tone from the primary/alternate central station receiver. If No is entered, a 1400 Hz acknowledgement tone will not be accepted. Enter No if 2.3 Modem or 3.3 AModem is Yes.
3.5 AAck14	No		
2.6 EXT/R	Yes	Yes or No	Transmit <b>Expanded trouble and restoral</b> reports by zone number to primary/alternate central station receiver. See 1.1 Tbl and 1.2 Res for report codes. For Radionics Receivers enter Yes.
3.6 AExT/R	Yes		
2.7 Ack23	Yes	Yes or No	Accept a 2300 Hz acknowledgement tone from the primary/alternate central station receiver. Enter No if 2.3 Modem or 3.3 AModem is Yes.
3.11 AAck23	Yes		

## Routing

Call routing is a function of the D6112 which allows information to be reported to two different central stations.

Display	Default	Selections	Description
3.7 AlarmRoute		0 through 3	<b>Routing alarm</b> signals. See Routing Table for Program Entry descriptions.
3.8 OpClRoute		0 through 3	<b>Routing for opening and closing</b> signals. See Routing Table for Program Entry descriptions.
3.9 TblRoute		0 through 3	<b>Routing for trouble</b> signals. See Routing Table for Program Entry descriptions.
3.10 ResRoute		0 through 3	<b>Routing for restoral</b> signals. See Routing Table for Program Entry descriptions. NOTE: If "0" is selected for either 3.7 AlarmRoute or 3.9 TblRoute, then a "0" must also be entered in 3.10 ResRoute.

## Routing Table

Entry	Type	Response
0	Primary	Signal is sent to the Primary Telephone number only.
1	Primary, then Alternate	Signal is sent to the Primary Telephone number. If the signal cannot be sent to the Primary Telephone number, it is rerouted to the backup Alternate Telephone number.
2	Alternate, then Primary	Signal is sent to the Alternate Telephone number. If the signal cannot be sent to the Alternate Telephone number, it is rerouted to the backup Primary Telephone number.
3	Primary - Not Designated Alternate - Designated	Signal is sent to the Primary Telephone number if not a "designated" zone. "Designated" zones, programmed in "Digit Four" in the Zone Code Index, route signals to both the Primary Telephone Number and the Alternate Telephone number. NOTE: Battery restoral signals (1.7 Bat Supv), duress reports and cancel reports are always treated as designated zones for call routing transmission.

The following table displays a summary of the routing entries.

	ROUTING ENTRY				
	0	1	2	Designated Zone 3	Non-Designated Zone 3
PRIMARY NUMBER	All Reports	All Reports	Back Up All Reports	All Reports (1st)	All Reports
ALTERNATE NUMBER	N/A	Back Up All Reports	All Reports	All Reports (2nd)	N/A

#### Routing Operation:

When **routing entry 0** is used in DTMF mode, the D6112 makes five attempts to establish communication with the primary number before switching to pulse dialing. The D6112 will annunciate a "failure to report" after ten failed attempts to contact the receiver if 1.9 BzPhFail is Yes. A test report is automatically initiated once an hour after communication failure has begun and continues until communication is re-established. Only Com Fail reports are routed to the primary telephone number even if an alternate number is programmed. Other types of events will attempt to call both Primary and Alternate Central Stations. (See NOTE below.)

When using **routing entries 1, 2, or 3**, which enable two different telephone numbers, the D6112 makes two attempts to the primary telephone number, and if unsuccessful, makes two attempts to the secondary telephone number. Five attempts to establish communication with each number are made before switching to pulse dialing. After ten unsuccessful attempts to each number, the D6112 will annunciate a "failure to report" condition if 1.9 BzPhFail is Yes. Test reports are automatically initiated once an hour to the phone number(s) that was uncommunicative, until contact is re-established. (See NOTE below.)

The following is an example of the pattern that would be generated if routing entry 1 is used:

1. Primary	Tone or Pulse *
2. Primary	Tone or Pulse
3. Alternate	Tone or Pulse
4. Alternate	Tone or Pulse
5. Primary	Tone or Pulse
6. Alternate	Tone or Pulse
7. Primary	Tone or Pulse
8. Alternate	Tone or Pulse
9. Primary	Tone or Pulse
10. Alternate	Tone or Pulse
11. Primary	Pulse
12. Alternate	Pulse
:	:
:	:
19. Primary	Pulse
20. Alternate	Pulse

Failure to Report Signal - - transmit test report once per hour.

\* The dialing format (DTMF or Pulse) of the transmitted signal is determined by Program Item 1.11 DTMF.

**NOTE:** In order for a test report to be sent should a communications failure occur, a test report or a deferred test report must be programmed (in 9. Test Timer Module).



### 4. Devices Module: Command Center Characteristics

As many as four command centers and/or zone expansion devices may be connected to the D6112 (only two D640 Zone Expansion Centers can be installed in a system). The D6112 identifies the devices by the address (physical location) on the serial data loop and the model number.

The device number that is entered in 4.1 Device# appears in 4.2, 4.3, and 4.4. The example in Figure 1 shows that if a "2" is entered in 4.1 Device#, 4.2 becomes D2Model, 4.3 becomes D2Cmd, and 4.4 becomes D2Acct1.

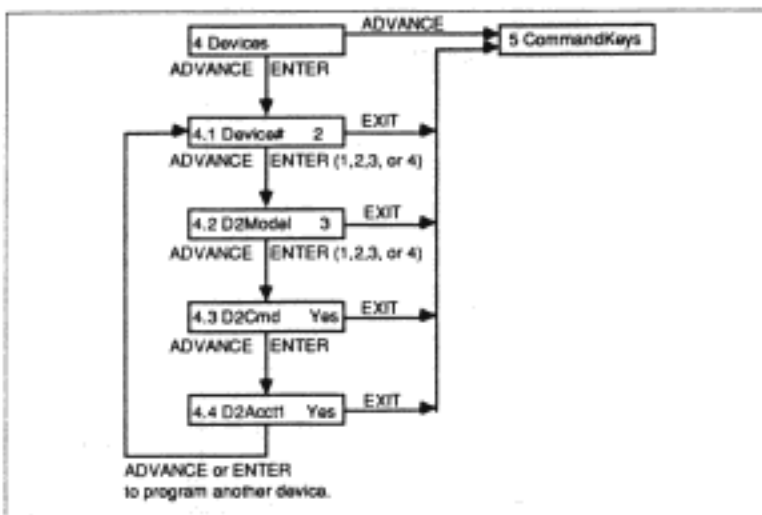

Figure 1: PROGRAMMING DEVICES

Display	Default	Selections	Description
4 Devices		ENTER or ADVANCE	Scan the ENTER bar code to access this module. Scan the ADVANCE bar code to bypass this module.
4.1 Device#	1	1 through 4	Enter the <b>device address number</b> .
4.2 D1Model	1	1 through 4	Enter the <b>device model code</b> (1=D610/D611, 2=D620/D626, 3= D630/D636, 4=D640). Only Device #1 defaults to 1 (D610/D611). Other device prompts have no default and are blank. <b>NOTE: Do not make program entries for a device which is not physically connected to the serial data loop.</b>
4.3 D1Cmd	Yes	Yes or No	Enter Yes to enable the <b>device COMMAND</b> key. Enter No if the device is installed outside the protected area.

NOTES: 1) 5.1 Comb9 selects the security passcode for the COMMAND key. If a passcode is entered in 5.1 Comb9 and 4.3 D1Cmd is No, keying in the passcode will override the 4.3 D1Cmd No. See 5.1 Comb9 for further details.  
2) Even though the device COMMAND key is enabled in 4.3 D1Cmd, COMMAND key functions must be individually enabled in the #5 COMMAND Keys Module. (At least one Command function in the Command Keys Module must be programmed in order to enable COMMAND 4.)

If a D6112 security system uses only one account, all installed command centers can arm and disarm the entire system. If a D6112 security system is divided into two accounts, each command center must be assigned to either Account #1 or Account #2. A command center assigned to Account #1 can arm and disarm zones assigned to Account #1, but cannot arm or disarm zones assigned to Account #2. A command center assigned to Account #2 can arm and disarm Account #2, but cannot arm or disarm Account #1.

4.4 D1Acct1	Yes	Yes or No	Enter Yes to assign the command center to allow arming and disarming of <b>Account #1</b> . Enter No to assign this device address to Account #2.
-------------	-----	-----------	---------------------------------------------------------------------------------------------------------------------------------------------------

Figure 2 displays a basic configuration consisting of a D6112 Control/Communicator and two Command Centers (a D620 and a D630). Since the D620 is the first device (the closest to terminal 11) on the serial data loop a "1" is entered in 4.1 Device#. A "2" is entered in 4.2 D1Model, since the device is a D620. The D630 is the second device on the serial data loop, so a "2" is entered in 4.1 Device#. A "3" is entered in 4.2 D2Model, since the device is a D630. If only one Command Center is connected to the D6112, it is assigned as Device #1. See Typical System Configurations for more device programming examples.

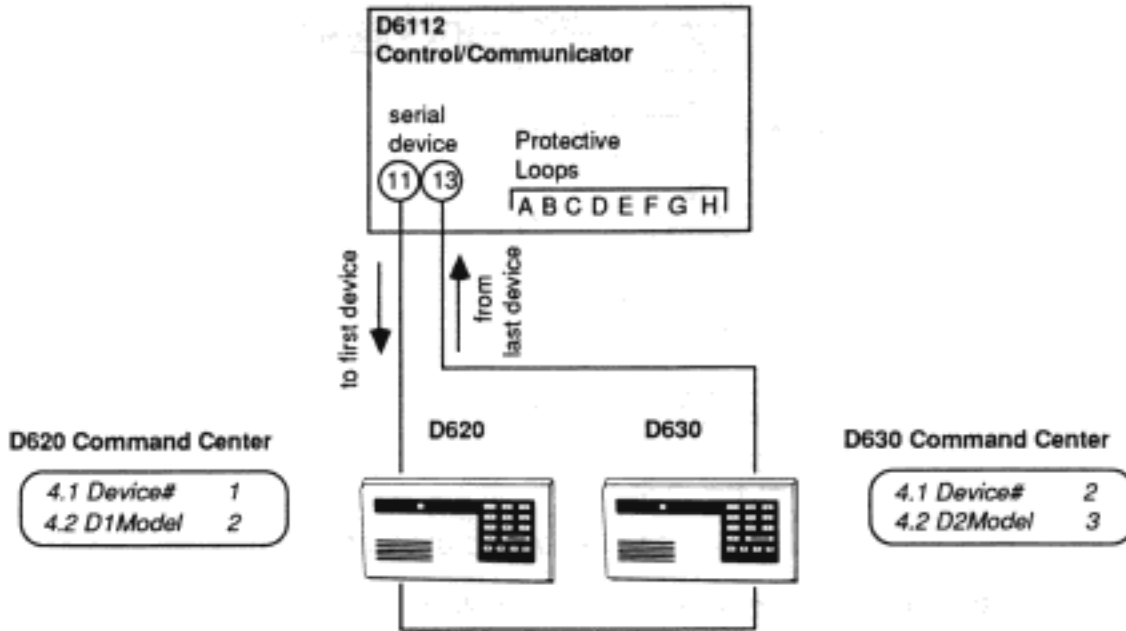

Figure 2: PROGRAMMING DEVICES

## 5. Command Keys Module: COMMAND Key Functions

The Program Items listed in this module pertain to both accounts of the D6112. Several of these options may be disabled by account (or by command center) after they are enabled in this module. Certain options should be carefully evaluated to determine whether they are appropriate for your specific installation.

Where command centers are accessible to unauthorized system users, and a higher degree of COMMAND key security is desired, the use of 5.1 Comb9 is strongly recommended.

After a system has been master armed using COMMAND 1 or a passcode, COMMANDS 4, 40, 41, 42, 43, 44, and 47 are inoperable. If a system has been perimeter armed using COMMANDS 2, 3, or 8, COMMAND 4 silences trouble buzzers, but does not clear alarm memory; COMMANDS 40, 41, 42, and 47 operate as described in this manual, and COMMANDS 43 and 44 are inoperable.

NOTE: COMMANDS 41, 42, and 44 (system tests) do not test the battery.

For operation instructions concerning command functions, consult the appropriate command center manual.

Display	Default	Selections	Description
5 CommandKeys		ENTER or ADVANCE	Scan the ENTER bar code to access this module. Scan the ADVANCE bar code to bypass this module.
5.1 Comb9		0 through 9 Blank	Enter a <b>combination</b> from one to four digits in length to complete the security passcode for the command center COMMAND key. Blank Entry = no COMMAND key security passcode.

The COMMAND key security passcode has a hard coded first digit which is 9. The hard coded digit is part of the passcode and *must* be the first digit entered when using the passcode. When a security passcode is programmed in 5.1 Comb9, the implementation of all COMMAND key related functions (and the use of the A, B, and C keys) are prevented unless the security passcode is entered. To use the security passcode to enable the COMMAND key, enter the passcode, press the ENTER key, and then press the COMMAND key. NOTE: If a code is entered in 1.6 Duress, and the last digit of the security passcode is increased by one, a duress report will be sent to the central station (see also 7.12 1Duress/8.12 2Duress).

The programmed state of 4.3 D1Cmd, which enables the COMMAND key at each command center, affects the operation of 5.1 Comb9. The table below displays the methods of access.

Access by . . .	4.3 D1Cmd	5.1 Comb9
COMMAND key only	Y	Blank
Combination only	N	#####
Either COMMAND key or Combination	Y	#####
No access	N	Blank

Display	Default	Selections	Description
5.2 Cmd1	No	Yes or No	Enable <b>COMMAND 1</b> to master arm the system. Entry/exit delay time is provided, if programmed in 7.4 1DlyIn/8.4 2DlyIn and 7.5 1DlyOut/8.5 2DlyOut.
5.3 Cmd2	No	Yes or No	Enable <b>COMMAND 2</b> to instant perimeter arm the system (no entry/exit delay time).
5.4 Cmd3	No	Yes or No	Enable <b>COMMAND 3</b> for delayed perimeter arming of an account (entry/exit delay time provided if programmed).

Display	Default	Selections	Description
5.5 FA123	No	Yes or No	Enable COMMANDs 1, 2, and 3 to <b>force arm</b> the account. NOTE: Enter Yes to force arm with a standard passcode.
5.6 Cmd0	No	Yes or No	Enable <b>COMMAND 0</b> for zone shunting from the command center while system is in exit delay mode.
5.7 FAMax	0	0 through 9	Enter the <b>maximum</b> number of faulted zones per account allowed when <b>force arming</b> . Enter "0" disallow force arming.
5.8 Cmd8	No	Yes or No	Enable <b>COMMAND 8</b> for perimeter arming with entry/exit delay time. Any faulted perimeter zones are shunted while arming with this command. NOTE: The use of <b>COMMAND 8</b> will <i>override</i> priority zones.
5.9 Cmd41	No	Yes or No	Enable <b>COMMAND 41</b> to send unexpanded restoral reports to the central station. NOTE for two accounts: If both accounts simultaneously request the transmission of a restoral report, only <i>one</i> of the accounts will transmit a report.
5.10 Cmd42	No	Yes or No	Enable <b>COMMAND 42</b> to send system trouble reports to the central station. See <b>System Trouble Report Codes</b> for more information.
5.11 Cmd44	No	Yes or No	Enable <b>COMMAND 44</b> to initiate local system test.
5.12 Cmd47	No	Yes or No	Enable <b>COMMAND 47</b> to reset the smoke and glass break detector zones and the command centers. NOTE: <b>COMMAND 47</b> does NOT disable the auxiliary power (D6112 terminal 7).  If <b>Cmd47</b> is programmed Yes, disable the Command Bar on all devices located outside the protected area. (See 4.3 D#Cmd.)
5.13 C47Shrt	Yes	Yes or No	Enter Yes to use a <b>short</b> reset time (2 seconds) for <b>COMMAND 47</b> . Enter No for a long reset time (4 seconds).
5.14 Cmd5	No	Yes or No	Enable <b>COMMAND 5</b> to put the system in the passcode change mode. If this feature is enabled, it is strongly recommended that a security passcode be entered in 5.1 <i>Comb9</i> to ensure a higher degree of <b>COMMAND</b> key security.
5.15 Cmd6	No	Yes or No	Enable <b>COMMAND 6</b> to put the system in the perimeter watch mode.

Program Items 5.16 through 5.25 determine the responses that occur when COMMANDs 7 and 9 are entered at a command center. These software zones are programmed independently from hardware loops that may have identical zone numbers. NOTE: Responses programmed for the same hardware and software zone (i.e. COMMAND 7 and hardware loop 7) can generate duplicate reports.

Display	Default	Selections	Description
5.16 C7RptCd		0 through 9 B through F Blank	Enter <b>report code</b> for <b>COMMAND 7/9</b> alarm to complete the <b>ALARM ZONE</b> __ report to the central station. Blank Entry = feature disabled. Suggested for use as medical or panic alert. For Radionics D6000 or D6500 Receivers operating in the D6000 format, do not use entries B through F. B through F can only be used for Modem II format.
5.21 C9RptCd			
5.17 C7Bell	No	Yes or No	Ring <b>alarm bell</b> when <b>COMMAND 7/9</b> is entered at a command center. (Bell output times are determined in 1.8 Bell.) A report code must be entered in 5.16 C7RptCd/5.21 C9RptCd for the alarm bell to operate.
5.22 C9Bell	No		
5.18 C7PlsBel	No	Yes or No	Enter Yes to <b>pulse alarm bell</b> when the <b>COMMAND 7/9</b> is entered at a command center. Enter No for steady bell output. Alarm bell output is selected in 5.17 C7Bell/5.22 C9Bell. This Program Item selects only pulse or steady output.
5.23 C9PlsBel	No		
5.19 C7AuxRly	No	Yes or No	Activate <b>auxiliary relay</b> when <b>COMMAND 7/9</b> is entered at a command center. The relay activation time follows the programmed bell time (see 1.8 Bell).
5.24 C9AuxRly	No		
5.20 C7DsgZn	No	Yes or No	Enter Yes for <b>COMMAND 7/9</b> report as a <b>designated zone</b> . Designated Zones are defined by Digit Four of the Zone Code. Program Items 3.7 through 3.10 contain information about designated zone reporting patterns.
5.25 C9DsgZn	No		
5.26 AKey		01 through 09 Blank	Select an operation for <b>key A/B/C</b> of the command center. NOTE: If NO is entered in 4.3 D1Cmd and a passcode is programmed in 5.1 Comb9, the A, B, and C keys will be "locked out" unless the security passcode is entered.
5.27 BKey			
5.28 CKey			

#### Function Key Operation Codes

Entry	Command	Operation Performed	Entry	Command	Operation Performed
01	CMD 41	Unexpanded Test Report	06	CMD 5	Passcode Change Mode
02	CMD 42	System Trouble Report	07	CMD 6	Perimeter Watch Mode
03	CMD 43	Initiate Remote Program	08	CMD 7	Keypad Alarm (Medical)
04	CMD 44	Local System Test	09	CMD 9	Keypad Alarm (Police)
05	CMD 47	Sensor Reset			

## 6. Combinations Module: Command Center Arm/Disarm Passcodes

The D6112 Control/Communicator can be programmed with up to seven arm/disarm passcodes. Each passcode can be from two to five digits in length, and may be programmed for a variety of responses. To arm and disarm a D6112 system with a programmed passcode, key in the passcode and then press the ENTER key. The passcode number that is entered in 6.1 *Comb#* appears in Program Items 6.2, 6.3, 6.4, and 6.5. The example in Figure 3 shows that if a "3" is entered in 6.1 *Comb#*, 6.2 becomes *Comb3*, 6.3 becomes *C3Ovrd*, 6.4 becomes *C3Acct1*, and 6.5 becomes *C3Acct2*.

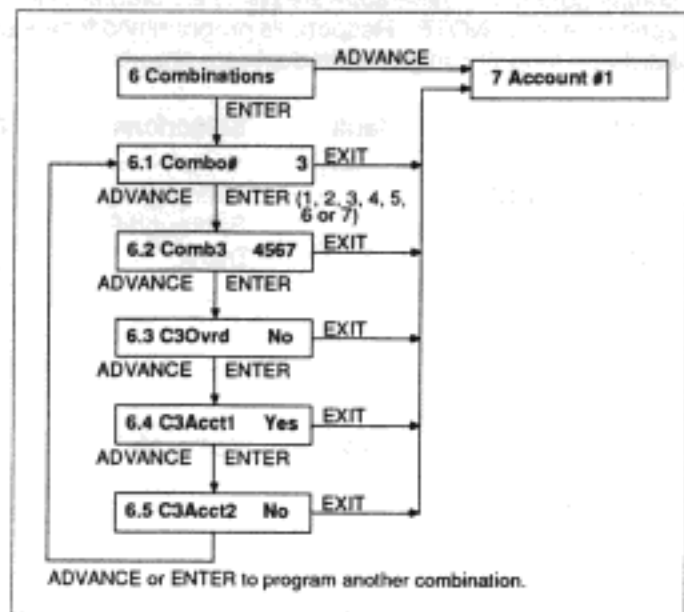

Figure 3: PROGRAMMING PASSCODES

Display	Default	Selections	Description
6 Combinations		ENTER or ADVANCE	Scan the ENTER bar code to access this module. Scan the ADVANCE bar code to bypass this module.
6.1 Comb#	1	1 through 7	Enter the <b>number</b> of the passcode you wish to program.
6.2 Comb1		0 through 9	Enter from one to four digits to complete the passcode. The passcode begins with the number shown in the display prompt. Example: Comb1 (passcode #1) begins with a "1".
6.3 C1Ovrd	No	Yes or No	The passcode will <b>override</b> restrictions on transmitting opening and closing reports. See 7.7 1Op/C1/8.7 2Op/C1, 7.8 1ReOp/8.8 2ReOp, and 7.9 1ReCl /8.9 3ReCl for more information.
6.4 C1Acct1	Yes	Yes or No	Enter Yes to enable this passcode to arm and disarm <b>Account #1</b> . If No is entered, this passcode will not affect Account #1.
6.5 C1Acct2	No	Yes or No	Enter Yes to enable this passcode to arm and disarm <b>Account #2</b> . If No is entered, this passcode will not affect Account #2.

Each passcode can be assigned to arm and disarm either Account #1 and Account #2. If a passcode is not assigned to either account, that passcode is automatically linked to the auxiliary relay. When the passcode is entered at a command center, it activates the relay for the amount of time programmed in 1.16 *AuxRlyTm*.

A passcode linked to the auxiliary relay can be increased by one to send a duress report **only** if enabled in 1.6 *Duress*. A passcode linked to the auxiliary relay (and the auxiliary relay duress passcode) will activate the auxiliary relay even when the system is master or perimeter armed.

If both 6.4 *C1Acct1* and 6.5 *C1Acct2* are programmed Yes, Account #1 and Account #2 can be armed and disarmed with the **same** passcode. However, only those zones in the account assigned to the particular command center will be armed and disarmed (see 4.4 *D1Acct1*).

## 7. Account #1 Module

## 8. Account #2 Module

This module selects several functions of the D6112 security system, including account number, opening and closing reports, and protective zone assignments.

If a Radionics D6500 Receiver is equipped with firmware which supports Modem II format, as many as sixteen zones can report to Account #1 and Account #2: if ten zones report to Account #1, six reporting zones remain to be assigned to Account #2. With a Radionics D6000, sixteen zones can be assigned to a single account, with a maximum of ten reporting zones. The remaining zones must be local zones. Program Item 7.17 *Acct1Zns* selects the total number of zones assigned to Account #1. The remaining number of zones are automatically assigned to Account #2. Account #1 must have at least one zone. Zone #16 must be a local zone. Account #2 can have a maximum of 15 zones.

Generally, the transmission of Account #1 reports has priority over Account #2 reports. An alarm report from Account #2 will have priority over Account #1 non-alarm reports (i.e. trouble, opening, closing, etc.).

After programming Account #1, stroke the EXIT bar code and then ENTER Account #2 (module 8).

Display	Default	Selections	Description
7 Account #1		ENTER or ADVANCE	Scan the ENTER bar code to access this module. Scan the ADVANCE bar code to bypass this module.
8 Account #2			
7.1 1Acct		0 through 9 B through F Blank	Enter three or four characters for the central station account number for the Account. For a Radionics D6000 Receiver enter three characters; for a D6500 Receiver enter four characters if Modem II format is used, and three characters for other transmitting formats. Blank Entry = No account number.
8.1 2Acct			
7.2 1Off	No	Yes or No	Enter Yes to turn off all functions of the Account except remote programming. NOTE: If No is entered, the account can still be accessed by the remote programmer. If 7.2 1Off/8.2 2Off is then changed to Yes using the remote programmer, the account will be disarmed and turned off. At this point, remote programming can be initiated only from the central station (if 1.12 CSPrg is Yes, and 1.14 Pass, 1.15 AnsArm, and 1.16 AnsDis are programmed). COMMAND 4 3 will no longer be operational.
8.2 2Off	No		
7.3 1Local	No	Yes or No	Enter Yes for the Account to be a local alarm system (no central station reporting). If no account number is programmed in 7.1 1Acct/8.1 2Acct, the account defaults to local, even if 7.3 1Local/8.3 2Local is No.
8.3 2Local	No		
7.4 1DlyIn		10 through 120 Blank	Entry delay time in ten second increments for the Account. UL systems have a maximum entry delay of 40 seconds. Blank Entry = no entry delay time.
8.4 2DlyIn			
7.5 1DlyOut		10 through 120 Blank	Exit delay time in ten second increments for the Account. UL systems have a maximum exit delay of 60 seconds. Blank Entry = no exit delay time.
8.5 2DlyOut			
7.6 1Prwm	Yes	Yes or No	Sound prewarning buzzer during the Account entry delay time.
8.6 2Prwm	Yes		

The operation of 7.8 1ReOp and 7.9 1ReCl (Account #1), and 8.8 2ReOp and 8.9 2ReCl (Account #2), is affected by the programmed state of 6.3 C1Ovrd. For example, setting 6.3 C1Ovrd to Yes will allow the entry of the passcode to **override** restrictions on opening and closing reports (if 7.8 1ReOp is Yes and/or 7.9 1ReCl is Yes). The table below shows the effect of 6.3 C1Ovrd on these Program Items. This table also applies to opening and closing reports initiated from Account #2.

	6.3 C1Ovrd	7.7 1Op/Cl	7.8 1ReOp	7.9 1ReCl
No Restrictions on Openings and Closings	No Effect	Yes	No	No
Restrictions on Openings and Closings	No	Yes	Yes	Yes
Combination Overrides Restrictions on Openings and Closings	Yes	Yes	Yes	Yes

Display	Default	Selections	Description
7.7 1Op/Cl	No	Yes or No	Enable <b>opening/closing</b> reports initiated by command centers. See Program Items 1.3 <i>Open</i> and 1.4 <i>Close</i> for report codes. NOTE: Program Item 7.7 1Op/Cl (Account #1)/8.7 2Op/Cl (Account #2) must be programmed Yes for the next three Program Items to be active.
8.7 2Op/Cl	No		

**NOTE:** If telephone line or central station equipment problems prevent the D6112 from communicating an Opening Report for a supervised account upon disarming, the D6112 cannot be rearmed until it has made ten dialing attempts (approximately 10 to 15 minutes). After ten unsuccessful dialing attempts, a fail-to-communicate signal is indicated (the command center buzzer pulses, if 1.9 BzPhFail is Yes). This prevents an Opening Report from being "lost" without subscriber knowledge.

Display	Default	Selections	Description
7.8 1ReOp	No	Yes or No	Restrict <b>opening</b> reports from the <b>Account</b> to transmit only when disarming the system after an alarm.
8.8 2ReOp	No		
7.9 1ReCl	No	Yes or No	Restrict <b>closing</b> reports from the <b>Account</b> to transmit only when force arming the system or when zone shunting with COMMAND 0 (enabled in 5.6 <i>Cmd0</i> ).
8.9 2ReCl	No		
7.10 1CombID	No	Yes or No	Identify <b>opening/closing</b> reports from the <b>Account</b> by user passcode. Zone 9 is reported if the account was master armed from the D9310 remote programmer or master armed using COMMAND 1.
8.10 2CombID	No		
			Comb 1 = Zone 1      Comb 5 = Zone 5 Comb 2 = Zone 2      Comb 6 = Zone 6 Comb 3 = Zone 3      Comb 7 = Zone 7 Comb 4 = Zone 4      Remote Programmer or Cmd 1 = Zone 9
7.11 1CnclRpt	No	Yes or No	Enable <b>cancel reports</b> for the <b>Account</b> . If the system is disarmed during bell time, the alarm report is followed by a "cancel" report. See 1.5 <i>Cancel</i> for report code. If an alarm is canceled before the alarm report is transmitted, the cancel report will be transmitted <i>before</i> the alarm report.
8.11 2CnclRpt	No		



Display	Default	Selections	Description
7.12 1Duress	No	Yes or No	Enable <b>duress</b> reports from <b>Account</b> command centers.
8.12 2Duress	No		

The "duress" signal is a silent alarm that is transmitted if the system is armed or disarmed by increasing the last digit of the passcode by one. Example: If the standard passcode is 3194, the duress passcode is 3195 (see 1.6 *Duress for report code*). NOTES: 1) If the last digit of the standard passcode is 0, the last digit of the duress passcode is 1. 2) If the last digit of the standard passcode is 9, the last digit of the duress passcode is 0. 3) The duress report cannot be cancelled. 4) If 7.12 1Duress/8.12 2Duress is Yes and 1.6 Duress is blank, the duress passcode will disarm the system, but no duress report will be transmitted to the central station. 5) If a security passcode is entered in 5.1 Comb9, and a report code is entered in 1.6 Duress, increasing the last digit of the passcode by one will send a duress signal to the central station. 6) If a passcode linked to the auxiliary relay is increased by one, a duress report will be transmitted (see 6.4 C1Acct1 and 6.5 C1Acct2).

Display	Default	Selections	Description
7.13 1DlyRes	No	Yes or No	<b>Delay restoral</b> reports from the Account until the bell time expires, or until the bell is reset from a command center. Both audible and silent alarms start the bell time.
8.13 2DlyRes	No		
7.14 1Ring1	No	Yes or No	Enter Yes for <b>one alarm</b> output per zone for <b>Account</b> non-fire zones. Enter No for alarm output after every zone trip. If Yes is entered, alarms on non-fire zones do <i>not</i> restart the alarm output with a second trip from the same zone unless the system is disarmed and then re-armed. Alarms on fire zones (24 hour zones with pulsed bell response) do restart the alarm output.
8.14 2Ring1	No		
7.15 1TsBell	No	Yes or No	Automatic <b>bell test</b> after arming <b>Account</b> (follows closing report for supervised accounts). Bell test lasts for two seconds. NOTE for two accounts: If one account is conducting an automatic bell test, the other account, if armed during this time, will <i>not</i> generate a bell test.
8.15 2TsBell	No		
7.16 1Show	Yes	Yes or No	Enter Yes to <b>show</b> the zone status at command center while <b>Account</b> is disarmed. Enter No to hide the zone status display while the <b>Account</b> is disarmed. NOTE: Entering No does not hide the display of alarm memory at the command center. Refer to Zone Code Digit Five to make zones invisible.
8.16 2Show	Yes		

Display	Default	Selections	Description
7.17 Acct1Zns 8	8	1 through 16	Enter the total number of protective zones. If a Radionics D6500 Receiver is equipped with firmware which supports Modem II format, the system can have as many as sixteen reporting zones. With a Radionics D6000, sixteen zones can be assigned to the system, with a maximum of ten reporting zones. The remaining zones must be local zones. Zone #16 must be a local zone.

The zone number that is entered in 7.18 1Zone#/8.17 2Zone# appears in Program Items 7.19/8.18 and 7.20/8.19. The example in Figure 4 shows that if a "3" is entered in 7.18 1Zone#, 7.19 becomes 1Z3Loc and 7.20 becomes 1Zn3.

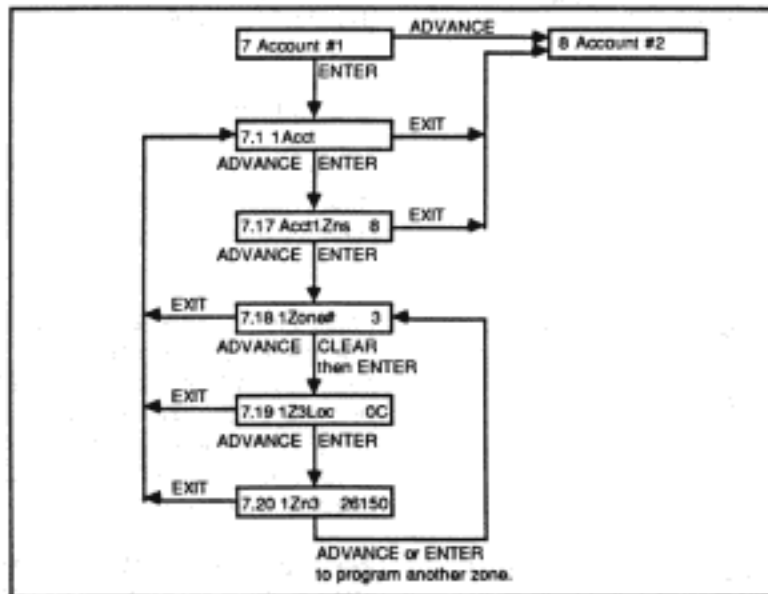

Figure 4: PROGRAMMING ZONES

Display	Default	Selections	Description
7.18 1Zone#	1	1 through 16	Enter the protective zone number you wish to program. To enter a zone number, CLEAR the default displayed and then enter the zone number.
8.17 2Zone#	1		
7.19 1Z1Loc	A	0 through 4 (device address)	Enter two character device address/zone location code. The first character identifies the device on which the zone is located. The device address of zones located on the D6112 is always "0". The address of zones located on installed D630s and D640s corresponds to the location identified in 4.1 Device#.
8.18 2Z1Loc	A	A through H (zone location)	The second character identifies the physical location of the zone on the device. Enter "Space A" for disabled zones.
			See <b>Typical System Configurations</b> for examples of programming 7.18/8.17 and 7.19/8.18.
7.20 1Zn1	00000	Zone Code Index	Enter a five digit response code for the protective zone specified. Enter five zeros if the zone is not used. See <b>Recommended Zone Codes</b> for standard selections.
8.19 2Zn1	00000		

## 9. Test Timer Module: Automatic Test Report Parameters

The D6112 can generate automatic test reports in accurate, programmable intervals, timed by an internal clock. Program Item 9.3 *Days* determines whether the interval is measured in daily or hourly increments, 9.4 *Intvl* selects the interval between reports, and 9.5 *DysRpt* and 9.6 *HrsRpt* determine the time until the initial report is transmitted. The automatic test report can transmit a RESTORAL ZONE E report (9.8 *TsE*) or a test code (9.7 *TsCode*) to the central station at test time. The D6112 sends the account numbers programmed for both Account #1 (7.1 *1Acct*) and Account #2 (8.1 *2Acct*), along with the test report. **NOTE:** Once timer settings have been entered in 9.5 *DysRpt* and 9.6 *HrsRpt*, do NOT disable/restart the Control/Communicator (simply disconnect the programmer cord). Disable/restart will default these program items.

Display	Default	Selections	Description
9 Test Timer		ENTER or ADVANCE	Scan the ENTER bar code to access this module. Scan the ADVANCE bar code to bypass this module.
9.1 TsPPh	No	Yes or No	Transmit automatic test report to the <b>Primary Telephone</b> number.
9.2 TsAPh	No	Yes or No	Transmit automatic test report to the <b>Alternate Telephone</b> number.
9.3 Days	Yes	Yes or No	Enter Yes to set automatic test time interval in <b>day</b> increments. Enter No to set interval in <b>hour</b> increments.
9.4 Intvl	0	0 through 63	Select automatic test time <b>interval</b> . Time measured in hours or days: see 9.3 <i>Days</i> to determine hourly or daily interval.
9.5 DysRpt	0	0 through 63	Number of <b>days</b> until the <i>first</i> automatic test report is transmitted.
9.6 HrsRpt	0	0 through 63	Number of <b>hours</b> until the <i>first</i> automatic test report is transmitted.
9.7 TsCode		0 through 9 B through F Blank	Transmit unexpanded automatic test report <b>code</b> . Blank Entry = no automatic test report code. When transmitting to a Radionics receiver, use 9.8 <i>TsE</i> for test report code. B through F can only be used with the Modem II format.
9.8 TsE	No	Yes or No	Transmit RESTORAL ZONE E at automatic test report time. If ten attempts to communicate with the receiver are unsuccessful, test reports are transmitted as Trouble Zone E (BFSK or pulse formats) or a Restoral Zone E (Modem II format) once per hour (see Routing Operation) until communication is re-established.

If either 9.1 *TsPPh* or 9.2 *TsAPh* are Yes and a code has been entered in either 9.7 *TsCode* or 9.8 *TsE*, a test report will be sent to the Central Station every 24 hours.

The D6112 may be programmed to defer test reports any time a system report is generated. In the defer mode (9.9 *TsDef*), if the D6112 generates any report other than the automatic test report, the time of the next report is deferred. For example, when a report is generated, the interval time is added to the present time of the D6112 internal clock. This sets the time of the next test report ahead. Automatic test reports may never be sent if the time of next test is continuously being deferred by other reports.

9.9 TsDef	No	Yes or No	<b>Defer test</b> reports when a system report is generated. NOTE: If Yes is entered, test reports from <i>both</i> accounts will be deferred.
-----------	----	-----------	---------------------------------------------------------------------------------------------------------------------------------------------------

## 10. Zone Code Index

The zone code index is used to construct five digit response codes for the protective zones of the D6112 Control Communicator (refer to Program Items 7.20 1Zn1 and 8.19 2Zn1). The response code determines how a zone responds to command centers and loop faults. **All five digits must be used in a zone code. Blank or incomplete entries will not work.**

### Digit One: Zone Response to Command Centers

Digit one determines the type of zone you are programming (e.g. 24-hour, interior, perimeter, priority). Descriptions of each type is given below. If you program your zone to be controlled (interior or perimeter), use the top part of the digit two chart to choose response to protective loops. If you program your zone to be 24 hour, use the bottom part of the digit two chart to choose response to protective loops.

**24-hour zone** — A 24 hour zone is not turned on and off from a Command Center. 24 hour zones are armed all the time, and can be used for fire protection (loop B only), and panic, medical, and police alerts. NOTE: A 24 hour zone cannot be shunted from a Command Center but it can be programmed for swinger shunt.

**Controlled zones** (Perimeter & Interior) — are armed and disarmed by a Command Center.

**Interior zone** — Zones programmed as interior are armed only by master arming the system. They are NOT armed when using perimeter arming commands. These zones are typically used to monitor interior detection devices.

**Perimeter zone** — Zones programmed as perimeter may be armed as a group, separately from zones programmed as interior. This permits the user to partially arm the system to establish perimeter protection and still occupy the interior of the protected premises.

**Priority zone** — Each protective zone is programmed as either a 24-hour zone, an interior zone, or a perimeter zone. Priority zones cannot be force armed or shunted out of the arming procedure. Priority zones must be normal (not faulted) while attempting to arm the account, or the account cannot be armed. NOTE: The use of COMMAND 8 (5.8 Cmd 8 Yes) will override priority zones.

Definition of each selection are as follows:

- 0 24 Hour Zone (zone is always armed, not turned on and off by a command center)
- 1 Interior Zone (can be left unarmed while perimeter arming)
- 2 Perimeter Zone (can be armed as a set, e.g. arm all perimeter zones)
- 3 Priority 24 Hour Zone
- 4 Priority Interior Zone
- 5 Priority Perimeter Zone

Digit One: Zone Response to Command Centers						
	0	1	2	3	4	5
24 hour zone	X			X		
Interior zone		X			X	
Perimeter zone			X			X
Priority zone				X	X	X

## Digit Two: Zone Response to Opens and Shorts on Loops

Digit two determines the zone response to an open or a short on a loop. The zone may be programmed to initiate a trouble signal, initiate an instant or delayed alarm, or ignore a fault on a protective loop. Descriptions of these options are as follows:

**Open** — An open circuit fault on the zone.

**Short** — A short circuit fault on the zone.

**Trouble** — Each protective zone is programmed to respond to open, short, and normal circuit conditions. Trouble is a response to an open or a short circuit condition. The Trouble response can generate a report to the central station, if programmed.

**Delay alarm** — Delay is a response to a detection circuit condition. When a user enters an armed system through a delay zone, the arming stations emit a warning tone to remind the user to disarm the system. If the system is not disarmed within the delay time (programmable), the system goes into alarm. **NOTE:** Items 7.4/8.4 and 7.6/8.6 must be programmed to enable delay alarms.

**Instant alarm** — Instant Alarm is a response to a detection circuit condition. When a user enters an armed system through a zone programmed for Instant Alarm, the system immediately initiates an alarm condition.

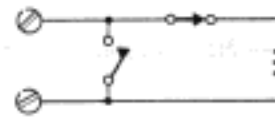

NORMALLY CLOSED AND NORMALLY OPEN CIRCUIT

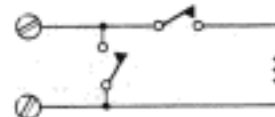

OPEN CIRCUIT FAULT

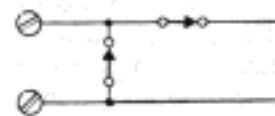

SHORT CIRCUIT FAULT

Definition of each selection are as follows:

- |                                                                |                                                                   |                                                                   |
|----------------------------------------------------------------|-------------------------------------------------------------------|-------------------------------------------------------------------|
| 0 No trouble, no delay, instant alarm on OPEN or SHORT         | 5 Delay on OPEN, instant alarm on SHORT, trouble on OPEN          | B Delay on SHORT, instant alarm on OPEN, trouble on OPEN or SHORT |
| 1 Trouble on OPEN, instant alarm on OPEN or SHORT              | 6 Delay on OPEN, trouble on SHORT, instant alarm on SHORT         | C Delay on OPEN or SHORT, no trouble conditions                   |
| 2 Trouble on SHORT, instant alarm on OPEN or SHORT             | 7 Delay on OPEN, trouble on OPEN or SHORT, instant alarm on SHORT | D Delay on OPEN or SHORT, trouble on OPEN                         |
| 3 Trouble on OPEN or SHORT, instant alarm on OPEN or SHORT     | 8 Delay on SHORT, instant alarm on OPEN, no trouble conditions    | E Delay on OPEN or SHORT, trouble on SHORT                        |
| 4 Delay on OPEN, instant alarm on SHORT, no trouble conditions | 9 Delay on SHORT, instant alarm on OPEN, trouble on OPEN          | F Delay on OPEN or SHORT, trouble on OPEN or SHORT                |
|                                                                | A Delay on SHORT, instant alarm on OPEN, trouble on SHORT         |                                                                   |

Digit Two: Zone Response to Opens & Shorts on Loops																	
		0	1	2	3	4	5	6	7	8	9	A	B	C	D	E	F
Controlled Zones	Open loop while armed	I	I	I	I	D	D	D	D	I	I	I	I	D	D	D	D
	Shorted loop while armed	I	I	I	I	I	I	I	I	D	D	D	D	D	D	D	D
	Open loop while disarmed	-	T	-	T	-	T	-	T	-	T	-	T	-	T	-	T
	Shorted loop while disarmed	-	-	T	T	-	-	T	T	-	-	T	T	-	-	T	T
24 Hr Zns	Open loop	A	T	A	T	-	-	A	T								
	Shorted loop	A	A	T	T	A	T	-	-								

Key to digit two: I = Instant alarm D = Delay alarm T = Trouble response A = Alarm (instant)

### Digit Three: Zone Local Alarm Response

Digit three determines the local alarm response of the selected zone. The zone may be programmed to produce a silent, steady, or pulse alarm output, activate the auxiliary relay, produce a ring override, or a combination of these responses.

**Silent alarm** — No local alarm, no voltage output to sirens or bells. An alarm report is generated to the central station, if programmed.

**Steady power output** — When an alarm is initiated from this zone, the voltage supplied to Terminal 5 of the D6112 is steady, continuous DC voltage. Voltage is supplied for duration of bell time (programmable) or duration specified in Digit Five of the zone code.

**Pulsing power output** — When an alarm is initiated from this zone, the voltage supplied to Terminal 5 of the D6112 is pulsing DC voltage. Voltage is supplied for duration of bell time (programmable) or duration specified in Digit Five of the zone code. NOTE: A programmed pulse output has priority over a programmed steady output. Controlled zones with pulsed bell outputs cannot be selectively shunted from the Command Center but they can be force armed..

**Auxiliary relay activation** — When an alarm is initiated from this zone, the auxiliary relay is activated for the duration of the programmed bell time (1.8 Bell) or the duration specified in Zone Code Digit Five. If a passcode is programmed, but not assigned to either account (see 6.4 C1Acct1 and 6.5 C1Acct2), entering the passcode activates the auxiliary relay for the duration programmed in 1.17 AuxRly Tm. The auxiliary relay can be activated by both the passcode and a zone alarm if both are programmed. A passcode linked to the auxiliary relay can be increased by one to send a duress report (if 1.6 Duress is Yes).

**1 Ring Override** — When an alarm is initiated from this zone, the alarm response is not limited to one ring. Selecting 1 Ring Override will pre-empt the ring response that is programmed in 7.14 1Ring1 and 8.14 2Ring1 for this zone. Zones programmed for 1 Ring Override can not be shunted using the Command 0 sequence but they can be force armed.

Descriptions of each selection are as follows:

- 0 Silent alarm, no alarm output
- 1 Steady alarm output for bells/sirens
- 2 Auxiliary relay activation for duration of bell timeout
- 3 Auxiliary relay activation and steady alarm output for bells/sirens
- 4 Pulsing alarm output for bells/sirens (overrides single bell per fault option)
- 5 Auxiliary relay activation (overrides single bell per fault option)
- 6 Auxiliary relay activation and pulsing alarm output for bells/sirens (overrides single bell per fault option)

Digit Three: Zone Local Alarm Response							
	0	1	2	3	4	5	6
Silent alarm	X		X			X	
Bell power		X		X	X		X
Pulse option					X		X
Aux. relay activation			X	X		X	X
1 Ring override					X	X	X

## Digit Four: Central Station Reporting Options

Digit four determines the central station reporting options such as the operation of the swinger shunt, the transmission of Restoral Reports, and the selection of the zone as "designated". If an entry of "0" is made for digit four, the zone does NOT initiate any reports to the central station, and only local alarms will sound (if programmed).

**Swinger shunt** — When four events (troubles or alarms) are detected by the swinger event counter during the D6112 one-hour window, the zone is shunted and a trouble report is communicated to the central station if the fourth event is an *alarm*. (If the fourth event is a *trouble*, a trouble report will *not* be sent.) The shunted zone is indicated by a slowly blinking zone LED at the command center. Shunts are cleared when the system is disarmed. If fewer than four events are detected by the swinger event counter during the D6112 one-hour window, the counter is cleared.

**NOTE:** Swinger shunt zones can be force armed (shunted out if faulted during arming). If a swinger shunt zone is restored after the system has been force armed, it will be included in the system and detect system faults. Zones *not* programmed with swinger shunt will *not* be included until the entire system is re-armed.

**Restoral reports** — transmitted after an alarm report or a trouble report, and indicate that the zone has been restored to normal.

**Designated zones** — Users of the D6112 system can select areas to be "designated zones". These zones have special routing instructions. When a Routing Telephone reporting pattern (Program Items 3.7 through 3.10) is set to "3", a "designated zone" transmits the selected report to both the Primary Telephone number *and* the Alternate Telephone number. If a "0", "1", or "2" is selected for the Routing Telephone reporting pattern, the "designated zone" bit of Digit Four has no effect.

Descriptions of each selection are as follows:

- 0 Non-reporting, local zone only
- 1 Standard reporting zone
- 2 Designated zone
- 3 Swinger shunt zone
- 4 Swinger shunt, designated zone
- 5 Standard reporting zone, includes restoral reports
- 6 Restoral reports, designated zone
- 7 Restoral reports, swinger shunt zone
- 8 Restoral reports, designated zone, swinger shunt zone

Digit Four: Central Station Reporting Options									
	0	1	2	3	4	5	6	7	8
Reports to central station		X	X	X	X	X	X	X	X
Swinger shunt				X	X			X	X
Restoral reports						X	X	X	X
Designated zone			X		X		X		X

## Digit Five: Local Zone Annunciation and Options

Digit five selects options pertaining to zone invisibility and alarm sounding. Detailed descriptions are given below. An entry of "0" for digit five produces no options: the zone status is constantly displayed at the command center, the condition of the zone does not affect bell time-out, and there is no audible indication of a zone fault at the command center.

**Invisible zone** — Invisible zones do not display zone status at the command center.

**Sound bells until restoral** — Alarms initiated from this zone cannot be silenced from the command center until the zone has been restored to normal. Overrides programmable bell time.

**Buzzer on fault** — When this zone is faulted (open or short circuit) the command center buzzes. Buzzers are silenced by zone restoral or by entering COMMAND 4 at the command center.

Descriptions of each selection are as follows:

- 0 No options
- 1 Invisible zone
- 2 Ring sirens/bells until zone restoral
- 3 Ring sirens/bells until zone restoral, invisible zone
- 4 Sound buzzers for zone fault
- 5 Sound buzzers for zone fault, invisible zone
- 6 Sound buzzers for zone fault, ring sirens/bells until zone restoral
- 7 Sound buzzers for zone fault, ring bells until zone restoral, invisible zone

Digit Five: Local Annunciation of Zones & Options								
	0	1	2	3	4	5	6	7
Invisible zone		X		X		X		X
Sound bells until restoral			X	X			X	X
Buzzer on fault					X	X	X	X



## 14. Recommended Zone Code

The Recommended 24 hour Zone Codes and Recommended Controlled Zone Codes have been designed with several standard functions, which are explained in the "24 Hour Zone Standards." Although these standard functions may be changed by personalizing your zone code with custom entries, these are the recommended codes from Radionics. Find the description which best identifies the zone to be programmed, then find the column which represents the type of reporting desired for that zone. At the intersection point of the column and the description is a zone code number.

### 24 Hour Zone Standards

- Fire zones initiate a pulsed bell output on alarm, while Panic & Holdup zones initiate a steady bell output (if audible).
- Fire zones have audible and visual annunciation at the Command Center during trouble alerts, while Panic & Holdup zones have only visual annunciation at the Command Center during trouble.
- Bell output expires after bell timeout, or when the correct passcode is entered at the Command Center.

	Trouble & Restoral	Trouble No Restoral	No Trouble No Restoral	Local No Reports	Restoral No Trouble
<b>Fire zones</b>					
Standard	01454	01414	04414	04404	
+ Unlimited bell	01456	01416	04416	04406	
<b>Panic &amp; Holdup (Audible)</b>					
Normally closed	02150	02110	00110	00100	
+ Unlimited bell	02152	02112	00112	00102	
+ Invisible zone	02151	02111	00111	00101	
+ Unlimited & invisible	02153	02113	00113	00103	
Normally open	01150	01110	00110	00100	
+ Unlimited bell	01152	01112	00112	00102	
+ Invisible zone	01151	01111	00111	00101	
+ Unlimited & invisible	01153	01113	00113	00103	
<b>Panic &amp; Holdup (Silent)</b>					
Normally closed	02050	02010	00010	n/a	
+ Invisible zone	02051	02011	00011	n/a	
Normally open	01050	01010	00010	n/a	
+ Invisible zone	01051	01011	00011	n/a	
<b>Independent Zone Controls</b> D268/D269 and D279	01150*		04110	04100	04150

\* NOTE: This loop code supervises the wiring between the control communicator and the sub-control only.

### Controlled (Burglar) Zone Standards

- Controlled zones initiated a steady bell output on alarm.
- Bell output expires after bell timeout, or when the correct passcode is entered at the Command Center.
- Controlled zones display their status at the keypad.
- While the system is armed, a controlled zone initiates an alarm for either an open loop or a shorted loop.

	Trouble & Restoral	Trouble No Restoral	No Trouble No Restoral	Local No Reports
<b>Perimeter Zones</b>				
Delay (normally closed)	26150	26110	24110	24100
+ swinger shunt	26170	26130	24130	n/a
Delay (normally open)	29150	29110	28110	28100
+ swinger shunt	29170	29130	28130	n/a
Instant (normally closed)	22150	22110	20110	20100
+ swinger shunt	22170	22130	20130	n/a
Instant (normally open)	21150	21110	20110	20100
+ swinger shunt	21170	21130	20130	n/a
Glass Break Zone	23154	23114	20114	20104
Window Foil	23154	23114	20114	20104
<b>Interior Zones</b>				
Delay (normally closed)	16150	16110	14110	14100
+ swinger shunt	16170	16130	14130	n/a
Delay (normally open)	19150	19110	18110	18100
+ swinger shunt	19170	19130	18130	n/a
Instant (normally closed)	12150	12110	10110	10100
+ swinger shunt	12170	12130	10130	n/a
Instant (normally open)	11150	11110	10110	10100
+ swinger shunt	11170	11130	10130	n/a

## 12. Typical System Configurations

Figure 5 shows the zone assignments for a basic one-account D6112 security system with D620 and D630 Command Centers. The D6112 protective loops A through H (D6112 terminals 16 through 28) are assigned to zones 1 through 8. Note that the device address (the first character of Program Item 7.19 1Z#Loc) of all of zones located on the D6112 is "0". The D620 device address (programmed in 4.1 Device#) is "1", since the D620 is the first device on the serial data loop. The D630 device address is "2", since it is the second device on the serial data loop.

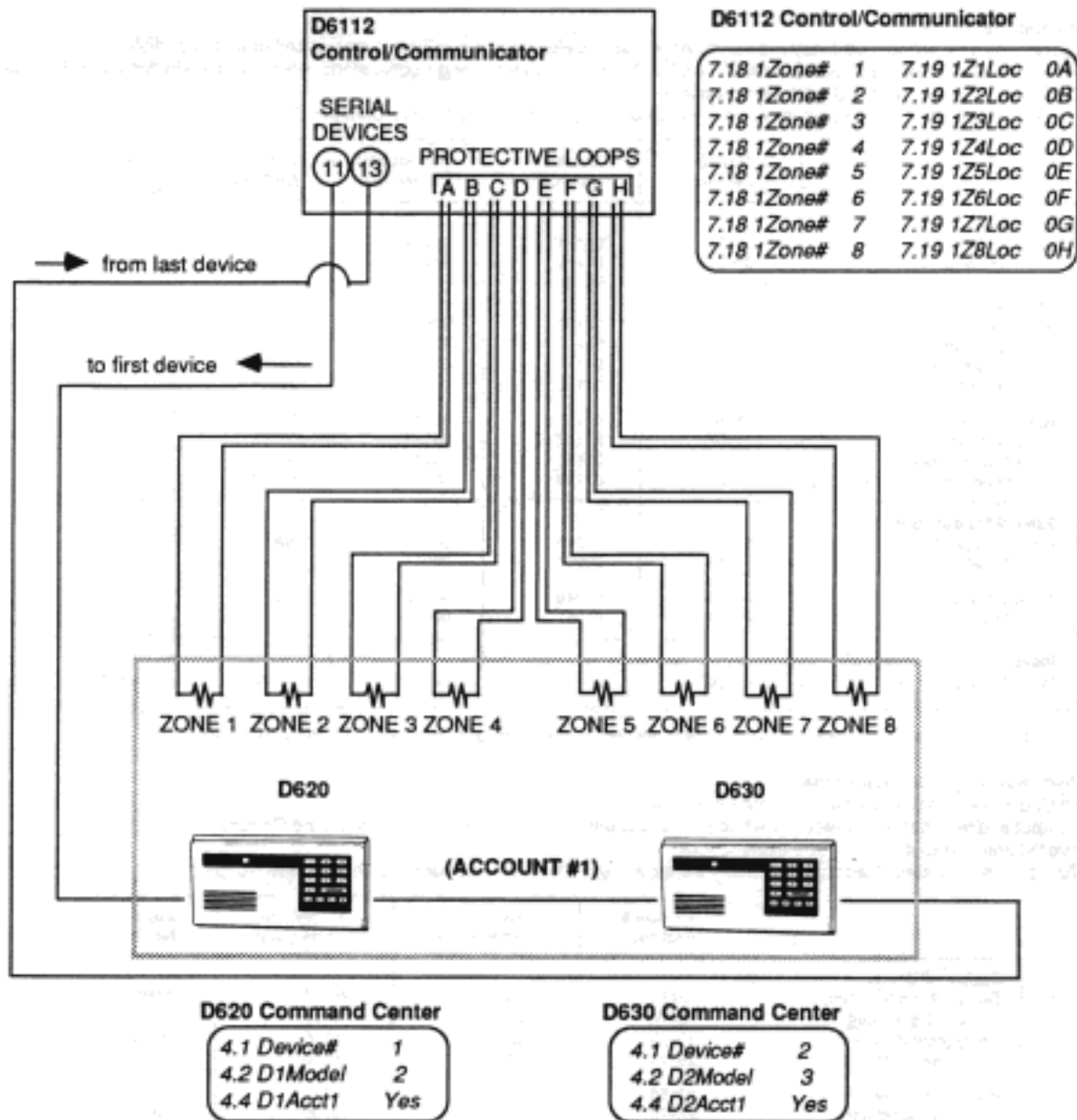

Figure 5: BASIC ONE-ACCOUNT SYSTEM

Figure 6 shows a D6112 security system which utilizes two accounts. The D620 Command Center is assigned to Account #1 (4.4 D1Acct1 Yes), and the D630 Command Center is assigned to Account #2 (4.4 D1Acct1 No). Protective Loops A through D of the D6112 are assigned to zones 1 through 4 of Account #1 (7.18 1Zone# and 7.19 1Z#Loc), and loops E through F are assigned to zones 1 through 4 of Account #2 (8.17 2Zone# and 8.18 2Z#Loc). In this example, the D620 Command Center can arm and disarm only D6112 zones 1 through 4, and the D630 can arm and disarm only zones 5 through 8.

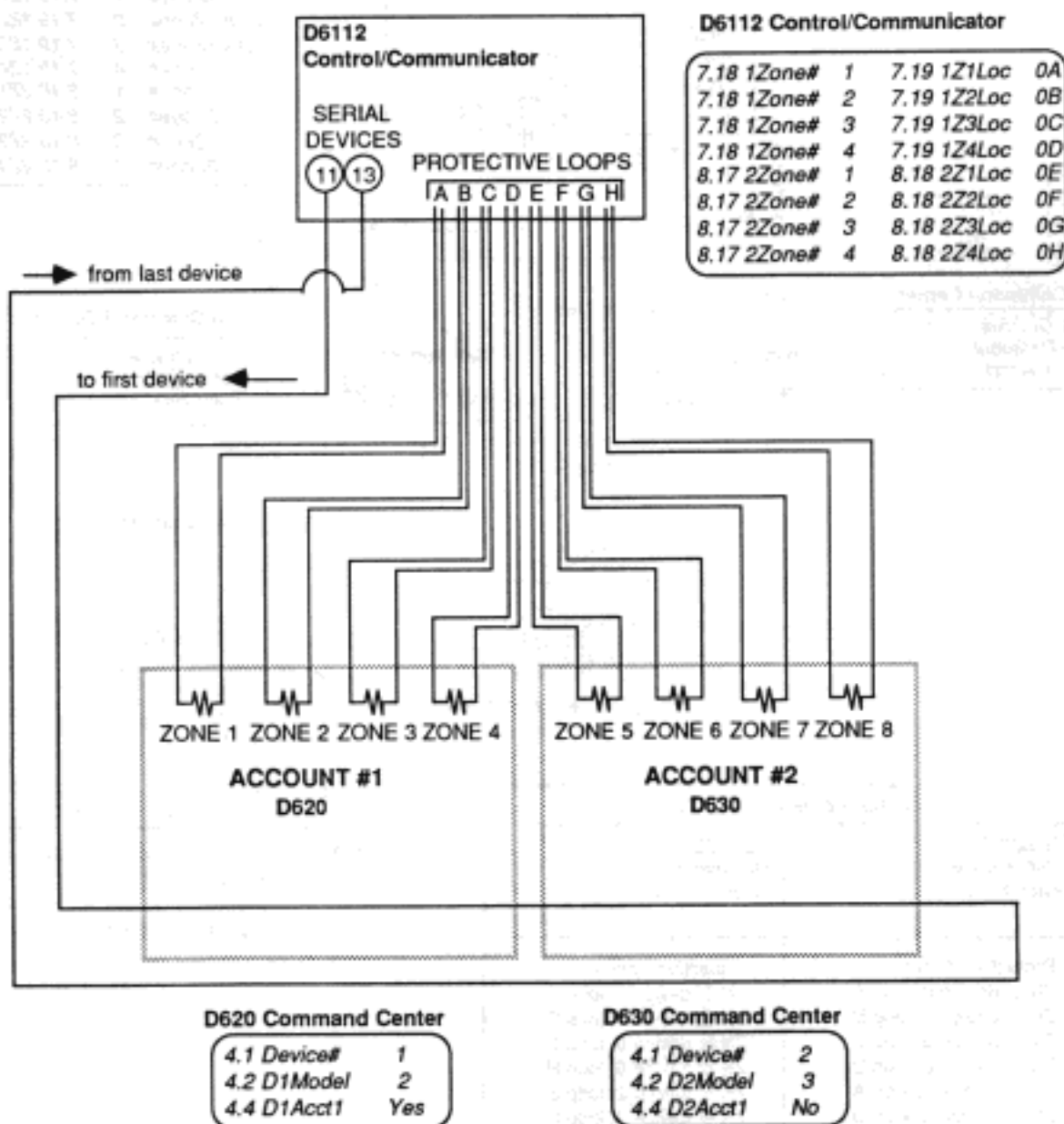

Figure 6: BASIC TWO ACCOUNT SYSTEM

Zones on Zone Expansion devices (D640 Zone Expansion Center or D630 Command Center) are assigned to either Account #1 or Account #2 in the same manner as D6112 zones. Figure 7 shows a system with a D640 Zone Expansion Center which has four zones assigned to Account #1, and two zones assigned to Account #2. The "Summary of Accounts" table indicates which zones and command centers are assigned to each account.

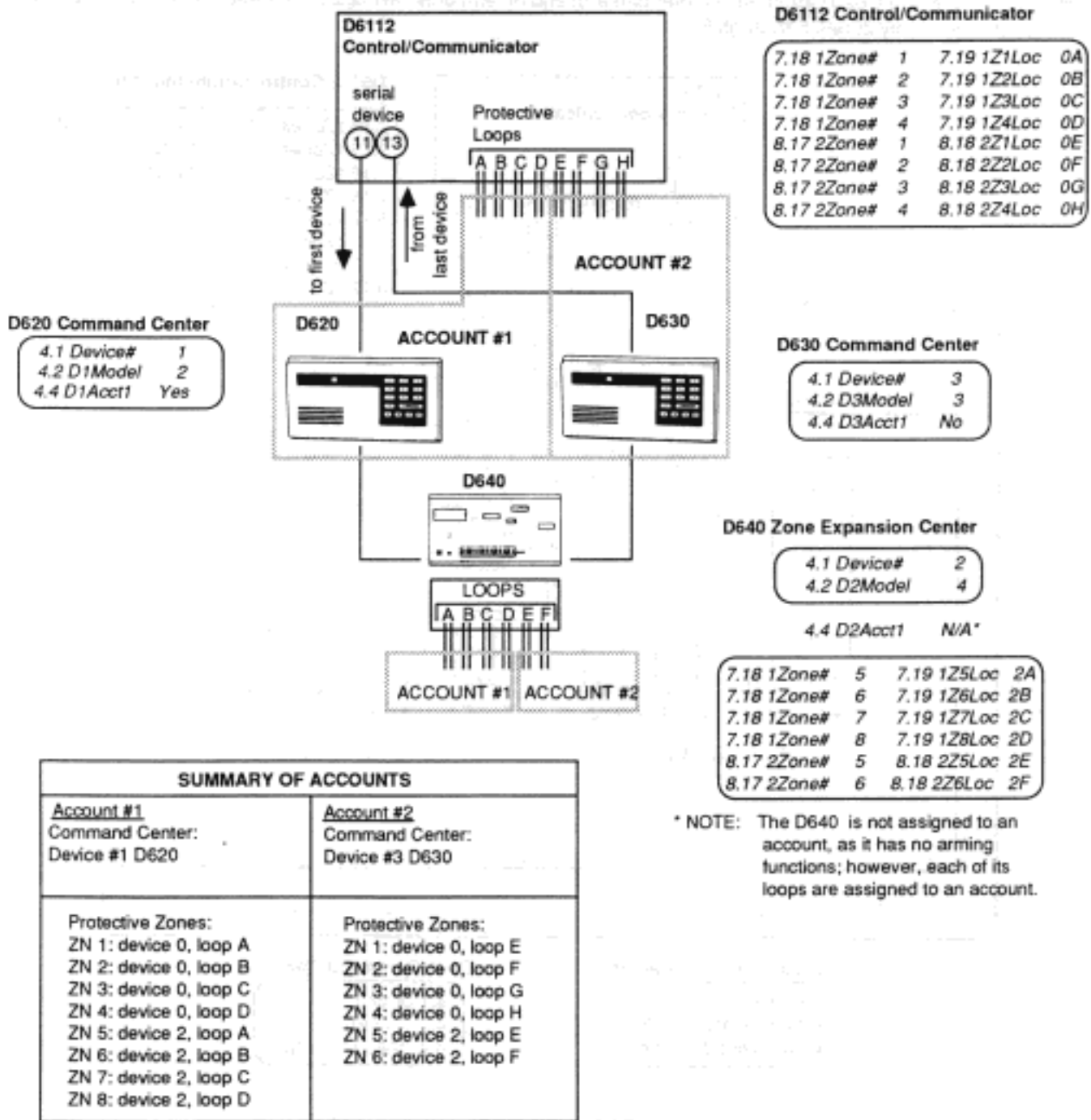
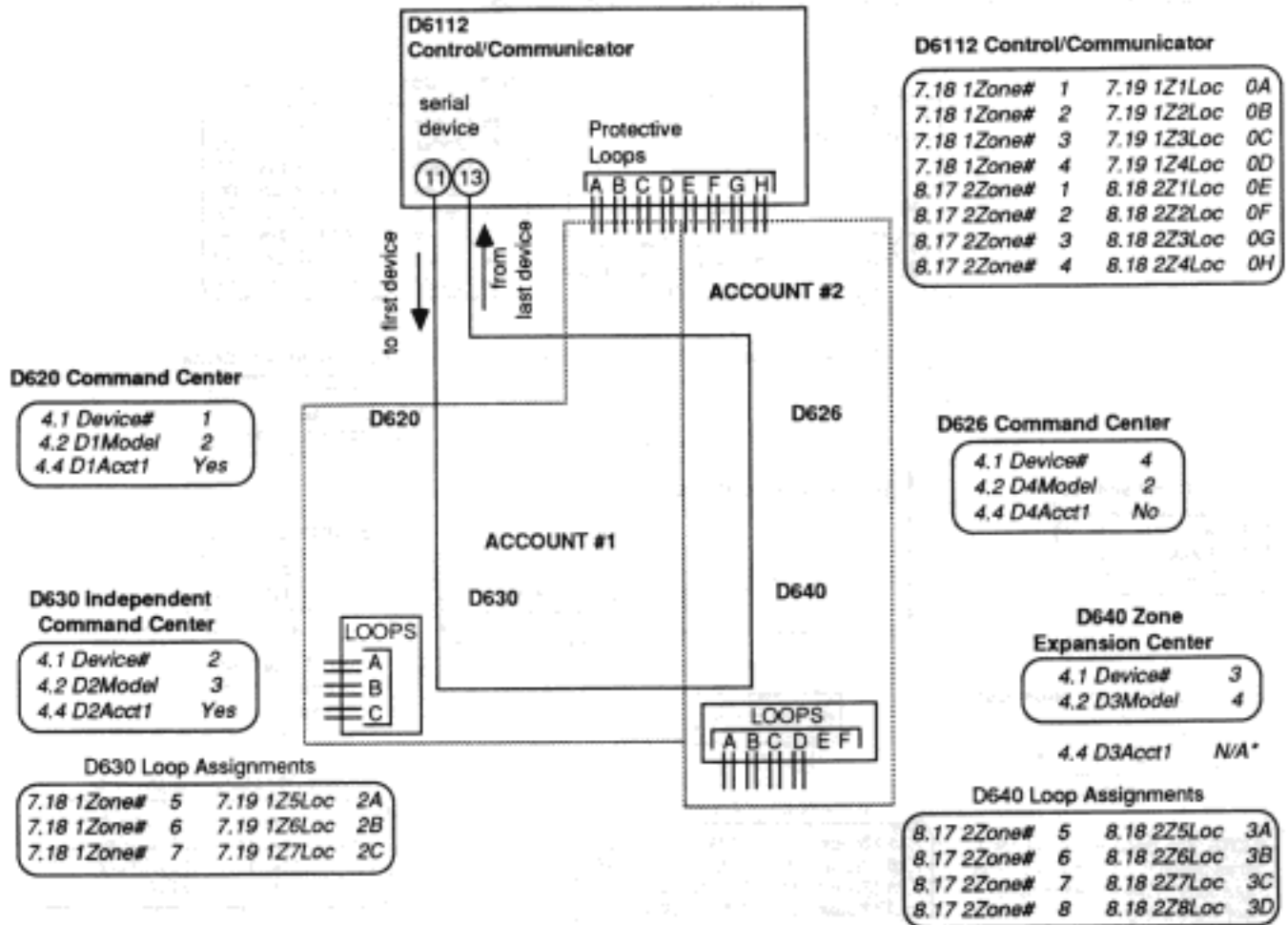

Figure 7: TWO ACCOUNTS WITH ZONE EXPANSION

Figure 8 shows a system with the maximum number of devices (four). This diagram shows the versatility of zone and device assignments within a single D6112 security system.



SUMMARY OF ACCOUNTS	
<b>Account #1</b> Command Centers: Device #1 D620 Device #2 D630	<b>Account #2</b> Command Centers: Device #4 D626
Protective Zones: ZN 1: device 0, loop A ZN 2: device 0, loop B ZN 3: device 0, loop C ZN 4: device 0, loop D ZN 5: device 2, loop A ZN 6: device 2, loop B ZN 7: device 2, loop C	Protective Zones: ZN 1: device 0, loop E ZN 2: device 0, loop F ZN 3: device 0, loop G ZN 4: device 0, loop H ZN 5: device 3, loop A ZN 6: device 3, loop B ZN 7: device 3, loop C ZN 8: device 3, loop D

\* NOTES: The D640 is not assigned to an account, as it has no arming functions; however, each of its loops are assigned to an account.  
 D640 Loops E and F are not used in this application.

Figure 8: MAXIMUM D6112 SYSTEM UTILIZATION

Figure 9 shows a system with two D626 Command Centers and two D640 Zone Expansion Centers. One D626 Command Center is located at the front door of the premises, and the second D626 is located at the back door. Two D640s are installed to provide the maximum number of zones (sixteen). All units are located in one account (Account #1), and both Command Centers annunciate all sixteen zones.

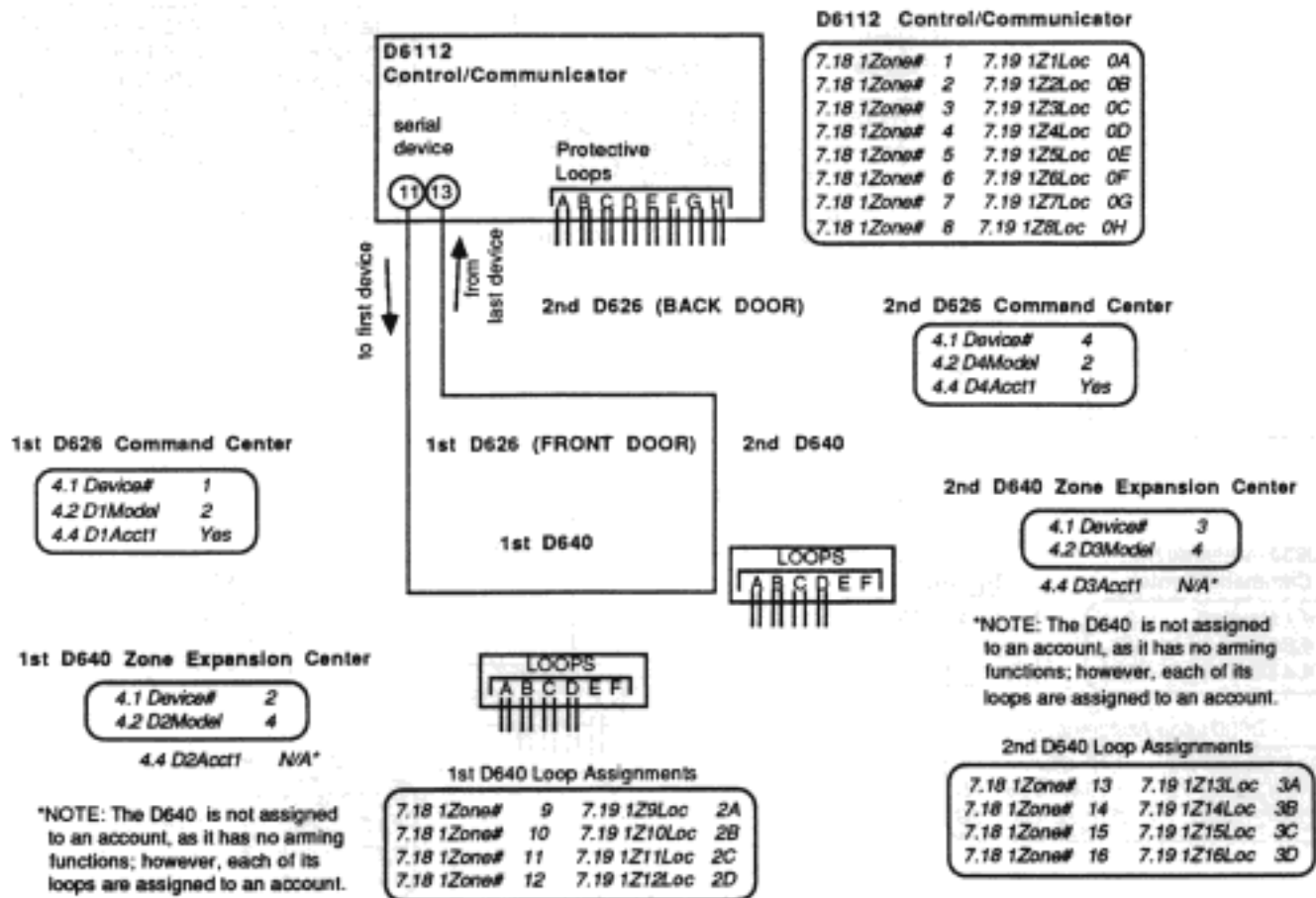

Figure 9: SIXTEEN ZONES ON ONE ACCOUNT

### 13. System Trouble Report Codes (COMMAND 42 and COMMAND 40)

Typically, when a system trouble occurs, the trouble buzzer of the Command Center will sound. When the subscriber calls his alarm company for service, the subscriber may be instructed to key in a COMMAND 42 (see 5.10 *Cmd42*).

If **pulsed format** is transmitted, only the trouble report code is sent to the central station. If there are *no* system troubles present when COMMAND 42 is entered, a restoral report will be transmitted. If the communicator transmits in **BFSK format**, a trouble report code and "STATUS REPORT" will be sent to the central station. If there are *no* system troubles, a restoral report and "STATUS REPORT" will be transmitted. If the **Modem II** format is used by the communicator, a trouble report code and "DIAG REPORT" will be sent to the central station. If there are *no* system troubles, a "DIAG REPORT" will be transmitted.

Keying COMMAND 40 at a D620 or D630 Command Center will replace the display of zone status on the four left indicator lights with a trouble report code. If applicable, a second trouble report can be displayed by keying in another COMMAND 40. Maximum number of troubles that can be held by COMMAND 40 is two. If no indicators light on the second COMMAND 40 entry, there is only one cause of system trouble. The table below indicates the nature of, probable source of, and required action for each trouble report. NOTE: Zones 1 through 4 must be programmed to enable COMMANDs 40 and 42.

After the panel is disabled/restarted, powered up, or serviced for the indicated system troubles, clear the system trouble memory by entering COMMAND 40 until no troubles are displayed. Press any key to exit COMMAND 40. (COMMAND 40 is *not* automatically exited upon an alarm or a trouble condition, although alarm and trouble signals continue to be transmitted to the central station.) A disable/restart will update the trouble display.

Indicator Lights				Trouble Report Code	Description	Probable Cause	Action Required
1	2	3	4				
<input type="checkbox"/>	<input checked="" type="checkbox"/>	<input type="checkbox"/>	<input checked="" type="checkbox"/>	0	D5100 Communication Error	bad connection to programmer	reprogram panel
<input checked="" type="checkbox"/>	<input type="checkbox"/>	<input type="checkbox"/>	<input type="checkbox"/>	1	Faulted Zone	protection loop fault	check zone status light
<input type="checkbox"/>	<input checked="" type="checkbox"/>	<input type="checkbox"/>	<input type="checkbox"/>	2	Command Center Communication Error	noisy environment or excessive wire length	service may be required
<input checked="" type="checkbox"/>	<input checked="" type="checkbox"/>	<input type="checkbox"/>	<input type="checkbox"/>	3	Communication Failure	unable to communicate with central station	service may be required
<input type="checkbox"/>	<input type="checkbox"/>	<input checked="" type="checkbox"/>	<input type="checkbox"/>	4	RJ38X Jack Supervision	phone cord unplugged or jack wired incorrectly	service may be required
<input checked="" type="checkbox"/>	<input type="checkbox"/>	<input checked="" type="checkbox"/>	<input type="checkbox"/>	5	Aux Power Supervision	probable short on auxiliary device or wiring	service is required
<input type="checkbox"/>	<input checked="" type="checkbox"/>	<input checked="" type="checkbox"/>	<input type="checkbox"/>	6	AC Power Fail	transformer unplugged	service may be required
<input checked="" type="checkbox"/>	<input checked="" type="checkbox"/>	<input checked="" type="checkbox"/>	<input type="checkbox"/>	7	Battery Supervision	low battery or battery fail	service may be required
<input type="checkbox"/>	<input type="checkbox"/>	<input type="checkbox"/>	<input checked="" type="checkbox"/>	8	Command Center Fault	Command Center wiring fault or interface failure	service is required
<input checked="" type="checkbox"/>	<input type="checkbox"/>	<input type="checkbox"/>	<input checked="" type="checkbox"/>	9	Internal Hardware Fault	main D6112 board failure (local zone inputs are probably inoperative)	service is required
<input checked="" type="checkbox"/>	<input checked="" type="checkbox"/>	<input type="checkbox"/>	<input checked="" type="checkbox"/>	B	Missing Serial Device	serial device failure	service is required
<input type="checkbox"/>	<input type="checkbox"/>	<input checked="" type="checkbox"/>	<input checked="" type="checkbox"/>	C	Device Programming Error	serial device does not match program	reprogram device
<input checked="" type="checkbox"/>	<input type="checkbox"/>	<input checked="" type="checkbox"/>	<input checked="" type="checkbox"/>	D	Internal Software Error/ Cmd Center Comm Problems	internal memory failure	call Radionics Customer Service
<input type="checkbox"/>	<input checked="" type="checkbox"/>	<input checked="" type="checkbox"/>	<input checked="" type="checkbox"/>	E	Checksum Fail	EEPROM failure	call Radionics Customer Service
<input checked="" type="checkbox"/>	<input checked="" type="checkbox"/>	<input checked="" type="checkbox"/>	<input checked="" type="checkbox"/>	F	System ROM Failure	internal ROM failure	call Radionics Customer Service

= indicator light ON  
 = indicator light OFF

Figure 10: TROUBLE REPORT CODES

Digit One: Zone Response to Command Center						
	0	1	2	3	4	5
24 hour zone	X			X		
Interior zone		X			X	
Perimeter zone			X			X
Priority zone				X	X	X

Digit Two: Zone Response to Opens & Shorts on Loops																	
Controlled		0	1	2	3	4	5	6	7	8	9	A	B	C	D	E	F
	Open loop while armed	I	I	I	I	D	D	D	D	I	I	I	I	D	D	D	D
	Shorted loop while armed	I	I	I	I	I	I	I	I	D	D	D	D	D	D	D	D
	Open loop while disarmed	-	T	-	T	-	T	-	T	-	T	-	T	-	T	-	T
	Shorted loop while disarmed	-	-	T	T	-	-	T	T	-	-	T	T	-	-	T	T
	24 Hour	Open loop	A	T	A	T	-	-	A	T							
Shorted loop		A	A	T	T	A	T	-	-								

I = Instant      D = Delay      T = Trouble      A = Alarm (instant)

Digit Three: Zone Local Alarm Response							
	0	1	2	3	4	5	6
Silent alarm	X		X			X	
Bell power		X		X	X		X
Pulse option					X		X
Aux. relay activation			X	X		X	X
1 Ring override					X	X	X

Digit Four: Central Station Reporting Options									
	0	1	2	3	4	5	6	7	8
Reports to central station		X	X	X	X	X	X	X	X
Swinger shunt				X	X			X	X
Restoral reports						X	X	X	X
Designated zone			X		X		X		X

Digit Five: Local Annunciation of Zones & Options								
	0	1	2	3	4	5	6	7
Invisible zone		X		X		X		X
Sound bells until restoral			X	X			X	X
Buzzer on fault					X	X	X	X



1800 Abbott Street P.O. Box 80012 Salinas, California 93912-0012  
 Customer Service: (800) 538-5807