

# R A D I O N I C S

## Omegalarm D8112 Control/Communicator Operation and Installation Manual



**Notice**

The material and instructions covered in this manual have been carefully checked for accuracy and are presumed to be reliable. However, Radionics, Inc. assumes no responsibility for inaccuracies and reserves the right to modify and revise this manual without notice.

It is our goal at Radionics to always supply accurate and reliable documentation. If a discrepancy is found in this documentation, please mail a photocopy of the corrected material to:

Radionics, Inc.  
 Technical Writing Department  
 1800 Abbott Street  
 Salinas, California 93901

**FCC Notice**

This equipment generates and uses radio frequency energy. If not installed and used in accordance with the manufacturer's instructions, it may cause interference to radio and television reception. It has been type tested and found to comply with the specifications in Subpart J of Part 15 of FCC rules for Class B Computing Devices. If this equipment causes interference to radio or television reception — which can be determined by turning the equipment off and on — the installer is encouraged to correct the interference by one or more of the following measures:

1) Reorient the receiving antenna of the radio/television, 2) Connect the AC transformer to a different outlet so the control panel and the radio/television are on different branch circuits, 3) Relocate the control panel with respect to the radio/television.

If necessary, the installer should consult an experienced radio/television technician for additional suggestions, or send for the following booklet prepared by the Federal Communications Commission.

"How to Identify and Resolve Radio-TV Interference Problems"

This booklet is available from the U.S. Government Printing Office, Washington D.C. 20402, stock no. 004-000-00345-4.

**Introduction**

This manual describes the operation and installation of the Omegalarm D8112 series Control/Communicator. Although there are different models of the D8112 series Control/Communicator (for example, the D8112F, the D8112G2, and D8112A) the installation for each unit is identical.\* Therefore, this manual covers general installation requirements for all models of the D8112 Control/Communicator. For details regarding the differences between models, see paragraph 1.4 Programming. Programming instructions for the D8112 Control/Communicator are described in *Program Entry Guides*. These Program Entry Guides describe the programs available to the various models of the D8112 and the hardware and software compatibility requirements. Read all documents carefully before attempting to install or program a D8112 Control/Communicator.

\* **Note:** Operational characteristics of D8112 Control/Communicators equipped with D8107 Input/Output boards manufactured prior to March 1, 1989 (date code 9021 or lower) are covered in Revision "F" of this manual. The Specifications listed in *this* manual (Rev. G, page 3) are for D8112 Control/Communicators equipped with D8107 Input/Output boards manufactured *after* March 1, 1989 (date code 9022 or higher).

The D8107 board was modified to meet U.L. requirements which became effective on March 1, 1989 for fire systems. The modification of the D8107 resulted in certain changes to the operation of the D8112 power supply and power supervision responses. To locate significant changes in this manual, observe the thin vertical lines in the margin (such as the line at the left side of this paragraph). These lines indicate changes made from the previous revision of the manual.

To ensure continuous satisfactory operation of any alarm system it must be installed properly, maintained regularly, and tested frequently. Offering a maintenance program and teaching the user the correct procedure to use and to test the system is the responsibility of the installing company.

## Table of Contents

(Circled numbers indicate D8112 terminals)

1. General System Description _____	4	10. The Protective Zones _____	14
2. The Control/Communicator Assembly _____	5	10.1 Description	
3. The Enclosure _____	6	10.2 Protective Zone Parameters	
3.1 Omegalarm D8103 Enclosure Specifications		11. Zone Expansion and Sync _____	15
3.2 Installing the Enclosure and D8112 Assembly		11.1 Zone Expansion (27) (28)	
4. Power Supply _____	7	11.2 Sync (25)	
4.1 Primary Power (1) (2)		12. Arming Stations _____	15
4.2 Secondary Power (4) (5)		12.1 Master Arm (Keyswitch Arming) (26) (29)	
4.3 Battery Supervision		12.2 Omegalarm Serial Data Command Centers (30) (31)	
4.4 Battery Charging Circuit		12.3 Force Arming	
4.5 Battery Supervisory LEDs		12.4 Selective Zone Arming	
4.6 Battery Circuit Protection		12.5 Optional Serial Data Equipment Connections to Terminal (31)	
5. Auxilliary Power Output _____	9	13. Accessory Connector Points _____	17
5.1 Auxilliary Power (3) (9)		13.1 Accessory Connector (J26)	
5.2 Switched Auxilliary Power (8) (9)		13.2 E.A.R. Connector (J24)	
5.3 System Common and Earth Ground (4)		14. Programmer & Test Connector (J2) _____	17
6. Alarm Power Outputs _____	9	15. Quick Reference Terminal Description _____	18
6.1 Description		16. Installation Guide for U.L. and Fire Alarm Applications _____	19
6.2 Bell Noise Filter		16.1 Optional Compatible Equipment	
6.3 Steady or Pulsed Alarm Output (6) (9)		16.2 Battery Standby Calculations for Fire Alarm Applications	
6.4 Alternate Alarm Output (7) (9)			
6.5 Alarm Power Output Responses			
6.6 Silent Alarm Output (8) (9)			
7. Plug-In Relays _____	11		
7.1 Description			
7.2 Location			
7.3 Installation			
8. Telephone Connections _____	12		
8.1 RJ31X or RJ38X Phone Jack			
8.2 Phone Cord Connection			
8.3 Phone Cord Supervision (10)			
9. Telephone Circuit Parameters _____	13		
9.1 Ground Start			
9.2 Telephone Line Sniffer			
9.3 Dual Line Transmitting			
9.4 TelCo Ring Light			

## Omegalarm D8112 Control/Communicator Specifications

### Voltage Input:

Primary	①	②	16.5 VAC 40 VA class 2 plug-in transformer (D1640)
Secondary	④	⑤	12VDC 6AH sealed lead acid rechargeable battery

### Auxiliary Power Outputs:

**Total power available for all Auxiliary Power Terminals is limited to 1 Amp @ 10.2 to 14 VDC combined output.**

Auxiliary Power Output	③	1 Amp maximum at 10.2 to 14 VDC [(continuous supply) total for all devices and outputs supplied by Auxiliary Power]
Switched Aux Power Output	⑧	Current drawn from auxiliary power supply. Voltage from this terminal may be interrupted (switched off) for approximately 4.5 seconds from the Command Center. Requires Plug-in Relay in socket K8 and programming. (See section 5.2)

### Alarm Power Outputs:

**Total power available for all Alarm Power Terminals is limited to 2 Amps @ 10.2 to 14 VDC combined output.**

Steady or Pulsed Output	⑥	2 Amps max. at 10.2 to 14 VDC supplied on alarm. Output may be steady or pulsed, depending on programming. (See section 6.5)
Alternate Alarm Output	⑦	2 Amps maximum at 10.2 to 14 VDC supplied on alarm. Requires Plug-in Relay in socket K6 and programming. (See section 6.4)
Silent Alarm	⑧	2 Amps maximum at 10.2 to 14VDC supplied on alarm. Requires Plug-in Relay in socket K7 and programming. (See section 6.6)

### Telephone Connections:

One TelCo Line	RJ31X or RJ38X jack can be interfaced with the D8112. RJ38X allows phone cord supervision. Phone line supervision for either jack is programmable.
Two TelCo Lines	Install Omegalarm D128 Dual Phone Line Module for two phone line service. Supervision supplied.

### Current Requirements:

D8112 Control/ Communicator	Idle:	150 mA
	Transmitting:	250 mA

**See the "D8112 Standby Battery and Current Rating Chart" in Section 16 for the current requirements of other system components.**

To comply with U.L. 985 and 864 listing standards for fire alarm systems (effective March 1, 1989), the **total power output for the system during alarm conditions** must be limited to 1.4 Amps (1400 mA) as provided by the Primary Power Supply (rectified AC), unless at least one D8132 Battery Charger Module is connected to the D8112. Each D8132 provides an additional 1.4 Amps (1400 mA) of rectified AC power. As specified above, the combined output from Auxiliary Power terminals is still limited to 1 Amp maximum at 10.2 to 14 VDC, and the combined output from Alarm Power terminals is still limited to 2 Amps maximum at 10.2 to 14 VDC.

## 1. General System Description

- 1.1 **Control Panel** - The Omegalarm D8112 Control/Communicator uses eight separate protection zones to detect and respond to intrusion and system status conditions. Each zone is programmed individually with several options to custom-fit the system to a particular installation. Optional zone programming responses include; *Alarm and/or Trouble and Restoral Reports by Zone, Instant or Delay Zone, Interior or Perimeter Zone, 24 Hour or Controlled (Burglary) Zone, Local Only Zone, Swinger Shunt and/or Priority Zone, Silent, Steady, or Pulsed Alarm Output, Alpha Command Center Custom Text, and more...*

The Control/Communicator can supervise AC (primary power), battery charge (secondary power), one or two telephone lines, and is programmable for automatic system test reports to an alarm central station. The Omegalarm D8112 Control/Communicator can also be programmed and interrogated (complete system status reports) from a remote central station.

- 1.2 **Communicator** - The Omegalarm D8112 Control/Communicator uses a built-in digital communicator for sending system data to a central station receiver. The Communicator can be programmed for most major receiver transmitting formats. (Consult the *Omegalarm 8112:MAIN Program Entry Guide* for details.) The Communicator can report to two separate phone numbers, using one or two telephone lines. The D8112 Control/Communicator connects to an RJ38X jack for phone line seizure and connector supervision. This complies with FCC regulations for using the public telephone network.

- 1.3 **EMI/Lightning Transient Protection** - The D8112 Control was designed to significantly reduce Electro-Magnetic Interference and malfunction, generally caused by lightning. Two printed circuit boards are interfaced in the D8112 assembly. The D8107 I/O (Input/Output) board has all the terminal connections and incorporates stringent input buffer components. The D8105 CPU (Central Processing Unit) board contains the more sensitive components such as the microprocessor, ROM and RAM program memory chips, and the lithium battery. The CPU board is isolated from the outside world, connecting only to the I/O board through an 18-pin connector.

Two lightning transient shields envelope the D8112 assembly; one shield (the CPU shield) wraps around the CPU board and the other shield (the faceplate/lightning shield) covers most of the assembly.

- 1.4 **Programming** - The D8112 can be programmed with either the Omegalarm D5100 Bar Code Programmer, or the D9301 Remote Account Manager. There are several models of the D8112 Control/Communicator. See the table (at right) for a quick reference of programs available to each model, then see the associated Program Entry Guide for details about the features available with each program.

D8112 MODEL →	E	E1	F	G	G1	G2	A
8112:MAIN	R	R	R	R	R	R	R
8112:AUX		OP	OP	R	R	R	R
8112:PTEXT				OP	OP	OP	
8112:SKEDS						OP	OP
8112:ACCESS							R
8112:ASSIGN							R
8112:CARDS							R
8112:COMEX						OP	

Key: "R" = Required Program  
"OP" = Optional Program

- 1.5 **Command Centers** - The D8112's controlled zones are armed and disarmed with the D360 and D1252 Command Centers. The Command Centers offer complete system control and annunciation. The D8112 can also be armed and disarmed with maintained or momentary closure devices, however, when these devices are used, serial data devices cannot be connected to the D8112. (See section 12 for details.)
- 1.6 **Independent Zone Controls** - The D8112's controlled zones can be armed and disarmed individually, regardless of the arm/disarm state of the control panel. This is accomplished with independent zone controls and special zone codes. Radionics offers several D8112 compatible independent zone controls. For example, the D279 Independent Zone Control is a single station independent zone control, while the D269 Independent Zone Control (used in conjunction with a D268 interface) is a multi-station, U.L. listed independent zone control.

## 2. D8112 Control/Communicator Assembly

The Omegalarm D8112 Control/Communicator is shipped pre-assembled from the Radionics factory. You should receive with your D8112 the following parts:

- 1) A Lit Pack containing this manual, appropriate program/account record sheet(s), eight end-of-line resistors and a set of color-coded battery leads.
- 2) A D8112 assembly consisting of a D8107 I/O board (Input/Output assembly), a D8105 CPU board (Central Processing Unit assembly), a faceplate shield, and a mounting skirt. The D8112 assembly is already complete and ready to mount in an Omegalarm enclosure.

When it's necessary to disassemble the D8112 assembly, use Figure 1 as a guide.

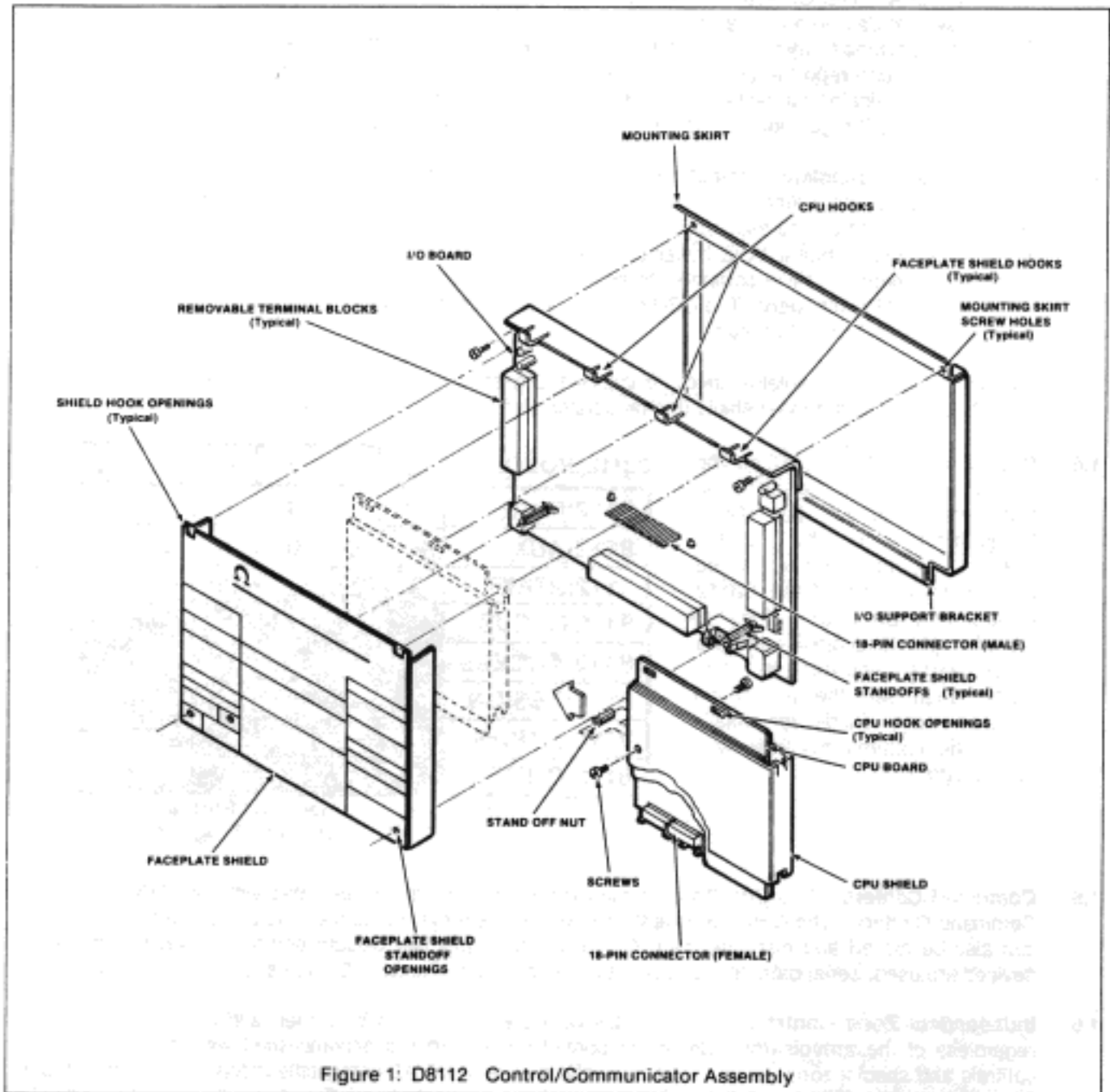

Figure 1: D8112 Control/Communicator Assembly

### 3. The Enclosure

The Omegalarm D8112 Control/Communicator assembly should be mounted into an Omegalarm enclosure. The standard enclosure for the D8112 is the D8103 Universal Enclosure (color: gray), however, you may install the unit into other Omegalarm enclosures, such as the D8109 Fire Enclosure (color: red) or D8108A Attack Resistant Enclosure (color: gray). The D8112 uses a mounting skirt to enable compatibility with these Omegalarm enclosures. (See Section 16 of this manual to determine the appropriate enclosure for the application.)

#### 3.1 Omegalarm D8103 Enclosure Specifications

Size:	16" x 16" x 3.5"
Weight:	10.5 lbs.
Construction:	18 gauge steel
Color:	Light Gray
Knockouts:	Two 1.5" wiring knockouts, eight 7/8" conduit knockouts.
Miscellaneous:	Four (three-hole) accessory equipment mounting locations. Two (three-hole) tamper switch mounting locations.

#### 3.2 Installing the Enclosure and D8112 Assembly

1. Mount the enclosure in the desired location.
2. Place the D8112 assembly over the inside back of the enclosure, aligning the large rectangular openings of the mounting skirt with the mounting hooks of the enclosure. Slide the D8112 down so it hangs on the hooks.
3. Remove the #6 x 1/4" screw from the mounting tab on the D8112 assembly. Insert the screw through the mounting tab and into the skirt mounting hole in the D8103 enclosure. Tighten the screw to secure the D8112 assembly to the enclosure.

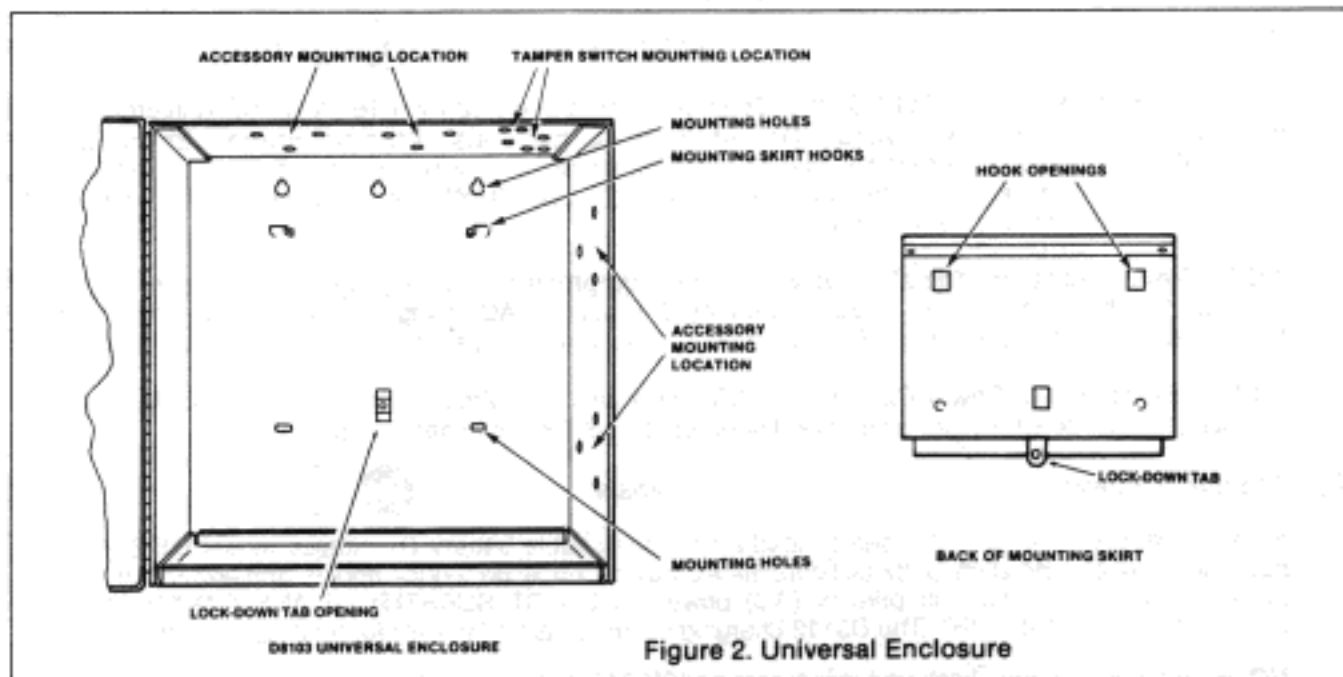

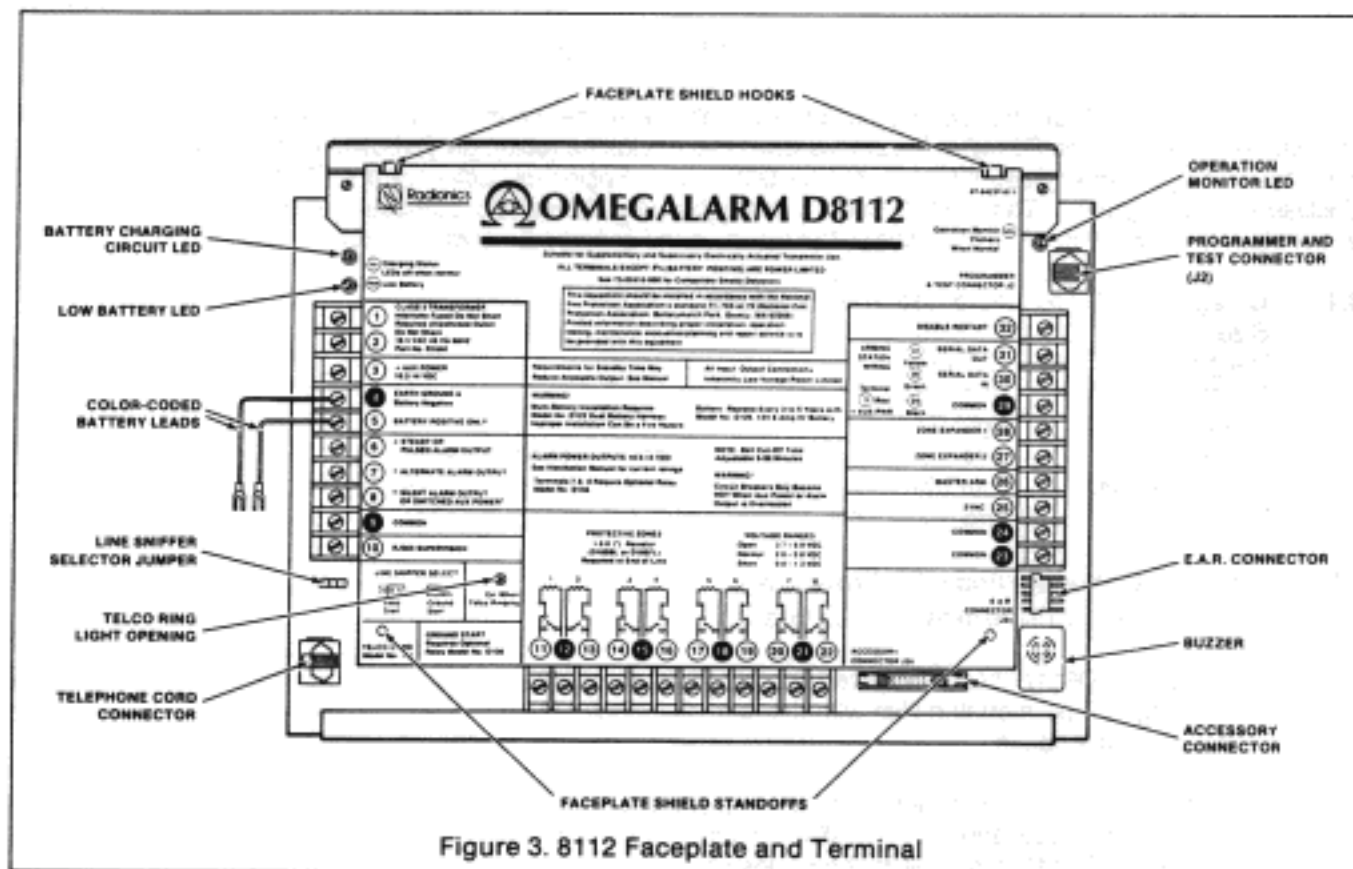

Figure 3. 8112 Faceplate and Terminal

## 4. Power Supply

### 4.1 Primary Power

#### Terminals

1 2

**4.1.1 Transformer** - The D8112 Control/Communicator is powered by a 16.5VAC 40VA internally fused transformer (Radionics model D1640). **Do not short the terminals of the transformer or the internal fuse will open causing permanent failure.** The transformer must be connected to a 120 VAC 60 Hz commercial power outlet not controlled by a wall switch. Use 18AWG wire (maximum length 50 feet) to connect the transformer to the Control/Communicator.

**NOTE: Never share the transformer with other equipment!** A foreign ground on the AC input will damage the Omegalarm power circuit. Even though insulated, AC wiring can induce both noise and low level voltage into adjacent wiring. Route both phone and loop wiring away from any AC conductors.

**4.1.2 Primary (AC) Power Circuit** - The AC power circuit provides 1.4 Amps of rectified AC power. It is protected from power surges by transient suppressors and 3 point spark gaps.

### 4.2 Secondary Power

#### Terminals

4 5

**4.2.1 Battery** - A 12V 6AH sealed lead-acid rechargeable battery (Radionics model D126) supplies power for auxiliary and alarm outputs, filters the AC power supply (to reduce ripple), and powers the security system during interruptions in primary (AC) power. **DO NOT SUBSTITUTE ANY OTHER TYPE OF BATTERY IN THIS CIRCUIT!** The D8112 charging circuit is calibrated only for lead-acid batteries.

**NOTE:** For longer battery back-up time, a second 12V 6AH battery may be connected in parallel to the first battery to form a 12V 12AH battery. Use a D122 Dual Battery Harness to ensure proper and safe connection. A D8132 Battery Charger Module can also be used to provide for connection of two additional batteries (12V 6AH, and/or 12V 15AH). See Section 16 of this manual for battery standby time calculations.

**4.2.2 Installation** - Install the battery in an upright position at the base of the enclosure and connect the negative side to terminal 4 (black lead), positive side to terminal 5 (red lead).

**WARNING:** Although the panel is protected against polarity reversal by a circuit breaker in series with the battery circuit, Terminal 5 can create high current arcs if shorted to other terminal inputs or the enclosure. Use caution when working with Terminal 5.



**4.2.3 Replacement** - Manufacturer recommends BATTERY REPLACEMENT EVERY 3 TO 5 YEARS under normal use. Do not exceed the maximum auxiliary and bell output ratings or install the transformer in an outlet that is routinely switched off. This causes repeated heavy discharges of the battery and will cause premature failure.

**4.3 Battery Supervision** - During an AC power loss the battery supplies all power to the security system. In doing so the battery slowly discharges. When the battery voltage drops to 12.1 VDC the Control/Communicator energizes the Low Battery LED and if programmed will send a "TROUBLE ZONE 9" report to the central station receiver(s). The cause of the low battery report should be investigated, since the panel becomes electrically inoperative when the voltage drops below 10.1 VDC.

*IMPORTANT: On D8112s and D8107s manufactured prior to 3/1/89 (date code 9021 or lower) the battery filters the AC power supply. If battery voltage drops below 12VDC there will be high ripple in the Aux power supply. Excessive ripple may cause equipment connected to Aux Power to malfunction.*

#### 4.4 Battery Charging Circuit

**4.4.1 Float Charge** - The float voltage for the battery charging circuit is 13.9 VDC at a maximum current of 1.4 Amps. The actual current available can be found by deducting any continuous load from 1.4 Amps.

**4.4.2 Load Shed** - During an extended AC power loss when the battery charge falls below 10.0 volts, a "load shed" relay isolates the battery from its power load (control, bell, and auxiliary power). This protects the battery from being damaged by deep discharge. The load shed does not prevent the battery from being recharged when AC power is restored. When AC has been restored the load shed relay resets and battery voltage is again available. See schedule below.

##### Battery Discharge/Recharge Schedule (no AC power)

Discharge Cycle	Recharge Cycle
13.9 VDC Charging float level	AC On Battery charging begins, Load shed relay resets, battery trouble & AC restoral reports sent
13.8 VDC Charging Circuit LED on	13.7 VDC Low battery LED off, battery restoral report sent, Charging Circuit LED off, battery float charged
12.1 VDC Battery trouble & AC Fail reports	
10.0 VDC Battery load shed (processing functions continue to operate if AC is connected)	

**4.5 Battery Supervisory LED's** - Two diagnostic LED's for the battery circuit are on the upper left corner of the I/O board. The yellow LED displays the status of the battery charging circuit. The red LED displays the condition of the battery voltage.

**4.5.1 Charging Circuit LED** - The *yellow* LED shows the status of the battery charging circuit. When the LED is "off," one of the following conditions exists: 1) Battery is connected and fully charged (normal), 2) Battery is not connected and the Aux load is less than 500 mA, 3) Battery polarity is reversed.

LED "on" means the charger is running at full rate. This can be a **normal** indication if: 1) Sirens or bells are operating, 2) Heavy intermittent load is on, 3) Recharging a low battery.

However, when the LED is "on," it can also mean: 1) No or low AC power input, 2) Battery is shorted, 3) Battery is not connected and the Aux load is more than 500 mA, 4) Excessive load.

**4.5.2 Low Battery LED** - The *red* LED shows the condition of the battery voltage. When the LED is "off," the battery is connected and charged to 12.1 VDC or above - or - no battery is connected and the Aux load is less than 500 mA.

LED "on" can mean: 1) Battery discharging below 12.1 VDC, 2) Battery recharging, but below 13.7 VDC, 3) Battery disconnected, shorted, or reversed, 4) Open circuit breaker, 5) No auxiliary power.

**4.6 Battery Circuit Protection** - Two self-resetting thermal circuit breakers protect the battery circuit from shorts. The circuit breakers are thermal rated and open at 4 to 5 Amps. The circuit breakers are supervised for sustained shorts and the communicator will transmit a "TROUBLE ZONE 9" report when they trip.

**WARNING:** Although the panel is protected from polarity reversal by a circuit breaker in series with the battery circuit, Terminal 5 can create high current arcs if shorted to other terminal inputs or the enclosure. Use caution when working with Terminal 5.

## 5. Auxiliary Power Output

### 5.1 Auxiliary Power

#### Terminals

3

9

**5.1.1 Description** - The D8112 supplies 1 Amp at 10.2 to 14 VDC to power auxiliary devices. A self-resetting circuit breaker protects this circuit against shorts. Devices powered from this output must operate over a range of 10.2 to 14 VDC.

**IMPORTANT:** On D8112s and D8107s manufactured prior to 3/1/89 (date code 9021 or lower) the battery filters the AC power supply. If battery voltage drops below 12VDC there will be high ripple in the Aux power supply. Excessive ripple may cause equipment connected to Aux Power to malfunction.

### 5.2 Switched Auxiliary Power

#### Terminals

8

9

**5.2.1 Description** - Terminal 8 can be used for one of two functions. This terminal can operate as a silent alarm output (see paragraph 6.6 Silent Alarm) or a switched auxiliary power output. The function selection is made by inserting a plug-in relay in one of two sockets (see section 7. Plug-in Relays). It is important to note that only ONE of the functions may be used; either silent alarm output or switched auxiliary power.

**5.2.2 Operation** - With a relay inserted in socket K8, terminal 8 supplies a continuous positive (+) 10.2 to 14 VDC auxiliary power output. The auxiliary power supply governs this output. Any load on this output should be combined with and limited to the ratings of the auxiliary power supply circuit.

This output can be temporarily interrupted by entering a Command 47 at the Command Center. This feature is used to reset smoke detectors, shock sensors, etc. See paragraph 5.2.3 for programming this feature.

**5.2.3 Programming** - Auxiliary power supplied from terminal 8 can be interrupted (switched off) for approximately 4.5 seconds by entering COMMAND 47 at a Command Center. To enable this option, program item #94 Cmd47 "Yes." Programming item #94 Cmd47 "No" does not disable the power output from terminal 8, however COMMAND 47 will not interrupt the power output.

**IMPORTANT:** Always program item #94 Cmd 47 "Yes" when using Switched Aux Power. If using Aux Power Output from terminal 8 (relay inserted in socket K8) with item #94 Cmd47 programmed "No," silent alarms will interrupt this power supply!

### 5.3 System Common and Earth Ground

#### Terminal

4

The D8112 should be connected to an earth ground reference (i.e. grounding rod, cold water pipe) through terminal 4. Use 16 AWG when making the connection to provide a path to ground for transient electrical surges. DO NOT USE TELEPHONE OR ELECTRICAL GROUND for the Earth Ground connection.

**NOTE:** Use only terminal 4 as earth ground connection.

## 6. Alarm Power Outputs

6

7

8

**6.1 Description** - The D8112 Control/Communicator supplies 10.2 to 14 VDC at 2 Amps maximum current for ALL alarm power outputs combined. A self-resetting circuit breaker protects this circuit against shorts and overloads. There are three possible alarm power output terminals:

1) Terminal ⑥ - steady or pulsed output, 2) Terminal ⑦ - alternate output (requires plug-in relay), and 3) Terminal ⑧ - silent alarm output (requires plug-in relay).

Steady or pulsed voltage and output time are selected during programming. Terminals 7 and 8 require plug-in relays for proper operation. See section 7. Plug-in Relays for installation.

- 6.2 **Bell Noise Filter** - An Omegalarm D8123 Bell Noise Filter must be installed when connecting impulse bells (motor or solenoid types) to a D8112 alarm power output terminal. The bell noise filter suppresses noise impulses on the wiring before this noise can return to the panel. The bell noise filter is installed at each bell, NOT at the panel. See Figure 4 for installation.

**NOTE:** Some vibrating horns will induce high noise levels into the power supply circuit. **TEST** vibrating horns for compatibility with the Omegalarm D8112 Control/Communicator before completing the installation!

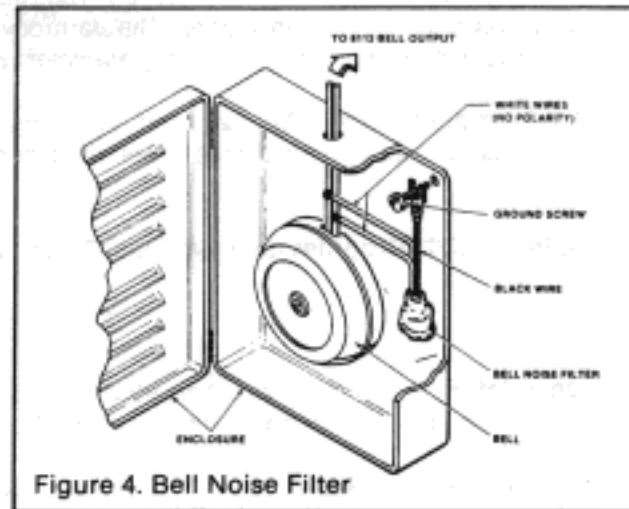

6.3 **Steady or Pulsed Alarm Output**

Terminals

6 9

Terminal 6 supplies positive (+) 10.2 to 14 VDC on alarm to power alarm annunciating devices. This output may provide steady and/or pulsed power output depending on zone code programming and programming of item #75 Pulse. See paragraph 6.5 for programming details.

6.4 **Alternate Alarm Output**

Terminals

7 9

Terminal 7 supplies positive (+) 10.2 to 14 VDC on fire alarm conditions to power fire alarm annunciating devices. This output provides steady power. Zone codes must be programmed with a 4 or an 8 in the third digit to trigger this output. *This alarm power output requires a plug-in relay inserted in socket K6 to operate.* See the chart below for programming details.

- 6.5 **Alarm Power Output Responses** - There are two different modes of operation for alarm power output terminals 6 and 7. Zone code programming determines if an alarm condition should be considered a fire or non-fire (burglar) alarm. Item #75 Pulse programs the Control/Communicator to respond to the alarm condition (fire or non-fire) in one of two ways.

**Program Item 75 Pulse "No"** (Terminal 7 requires a plug-in relay in socket K6 to enable this response.)

**NOTE:** Fire alarm has no priority. Both outputs can operate at the same time.

	Terminal 6	Terminal 7
Burglar Alarm (non-fire)	Steady +12VDC	No Output
Fire Alarm	No Output	Steady +12VDC

**Program Item 75 Pulse "Yes"** (Terminal 7 requires a plug-in relay in socket K6 to enable this response.)

**NOTE:** In this mode the fire alarm takes priority over any non-fire alarms. (i.e. Terminal 6 will pulse if both a non-fire zone and a fire zone are tripped simultaneously.)

	Terminal 6	Terminal 7
Burglar Alarm (non-fire)	Steady + 12VDC	No Output
Fire Alarm	Pulse + 12VDC	Steady + 12VDC

6.6 **Silent Alarm Output**

Terminals

8 9

**6.6.1 Description** - Terminal 8 can be used for one of two functions. This terminal can operate as a silent alarm output or a switched auxiliary power output (see paragraph 5.2 Switched Aux Power). The function selection is made by inserting a plug-in relay in one of two sockets (see section 7. Plug-in Relays). It is important to note that only ONE of the functions may be used; either silent alarm output or switched aux power. *Any load on this output should be combined with and limited to the ratings of the auxiliary power supply circuit.*

**6.6.2 Operation** - With a relay inserted in socket K7, terminal 8 supplies a continuous positive (+) 10.2 to 14 VDC power output on silent alarms. The alarm power supply governs this output. *Any load on this output should be combined with and limited to the parameters of the alarm power supply circuit.*

**6.6.3 Programming** - Protective zones are programmed by the third digit of the zone code for bell and buzzer response. By programming zone codes with a third digit of 1, 2, 5, or 6 the response to an alarm is a silent power output.

**IMPORTANT:** Program item #94 Cmd47 "No" when using Silent Alarm Output.

## 7. Plug-In Relays

**7.1 Description** - Plug-in relays are inserted into DIP (Dual In-line Pin) sockets to enable various functions of the Omegalarm D8112 Control/Communicator. The socket silkscreen callouts and functions are listed below:

K5 - Ground Start Relay

K7 - Silent Alarm (Terminal 8) Relay

K6 - Alternate Alarm (Terminal 7) Relay

K8 - Switched Auxiliary Power (Terminal 8) Relay

**NOTE:** Only three (3) plug-in relays can be installed simultaneously. Sockets K7 and K8 *cannot* be used at the same time. Only one function can be enabled from terminal 8 – either silent alarm output or switched auxiliary power.

**7.2 Location** - DIP sockets are located on the bottom left corner of the D8112 I/O board. Only the ground start socket (K5) is visible when the faceplate/shield is in place. The other three sockets are located under the shield. When the shield is removed, the sockets are positioned as shown in Figure 5.

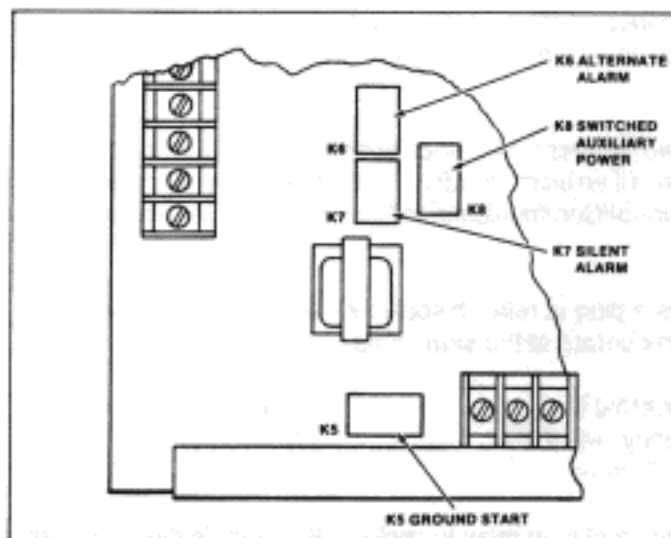

Figure 5. Plug-in Relay Location

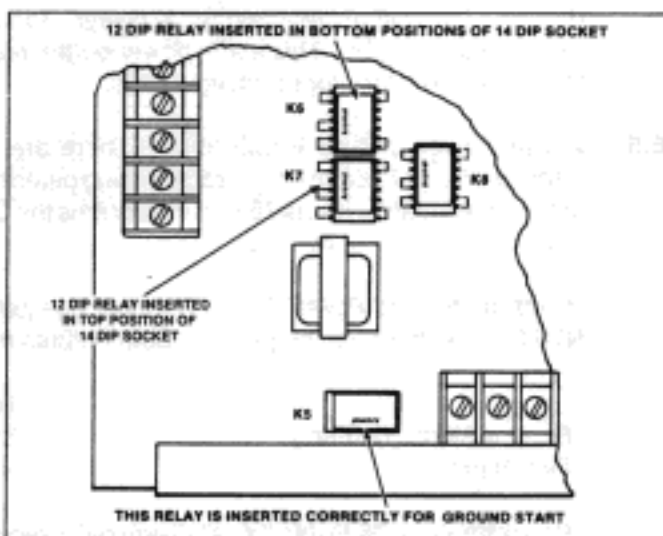

Figure 6. Plug-in Relay Installation

**7.3 Installation** - The plug-in relays (Radionics model D136) are packaged as a 12 DIP. The sockets (K5-K8) are a 14 DIP package. The sockets are designed so relays can be inserted using either the top or the bottom positions of the package as shown in Figure 6.

Each plug-in relay has two legs on one side and three legs on the other side. When inserting the relays, always ensure that the three leg side is to the left and the two leg side is to the right. The ground start socket (K5) should have the three legs down and the two legs facing the top of the D8112. Incorrect insertion will not damage the relay or the D8112, however the related circuit will not function.

## 8. Telephone Connections

### 8.1 RJ31X or RJ38X Phone Jack

**8.1.1 Registration** - The Omegalarm D8112 Control/Communicator is registered with the Federal Communication Commission under paragraph 68, for connection to the public telephone system using an RJ31X or an RJ38X jack installed by your local phone company.

FCC Registration Number: AJ-996H-14136-AL-R

Ringer Equivalence: 0.1B

**8.1.2 Location** - To prevent jamming of signals, the RJ31X or RJ38X jack must be wired and located within the system to support line seizure. Line seizure provides for a temporary interruption of normal phone usage while the communicator transmits data. After installation confirm that the communicator seizes the line, acquires dial tone, and reports correctly to the central station.

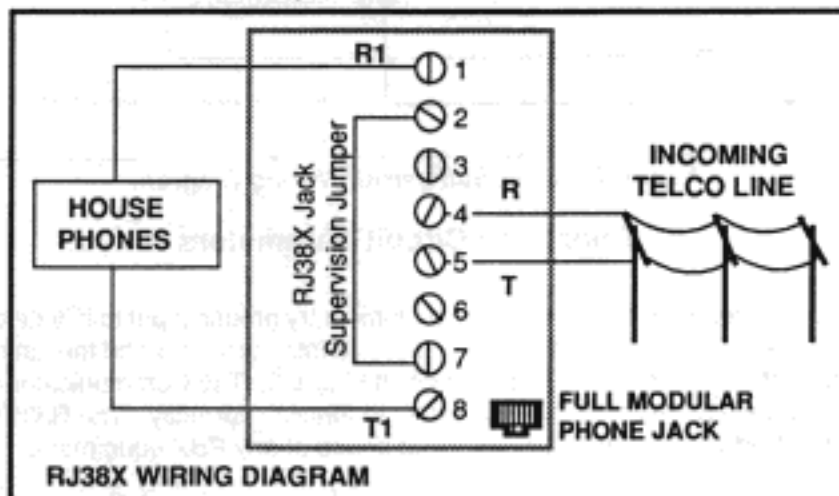

**8.1.3 Notification** - Registered equipment may NOT be connected to party lines or coin-operated telephones. The local telephone company must be notified and supplied with the following information before connecting the Control/Communicator to the telephone network.

- The particular line to which service is to be connected.
- Make, model, and serial number of the device.
- FCC registration number and ringer equivalence.

**8.2 Phone Cord Connection** - Connect one end of the D161 Phone Jack Interface Cord to the D8112 TelCo Cord connector (located on the bottom left corner of the D8112) and the other end to the full modular phone jack on the RJ38X.

The D161 Phone Jack Interface Cord can be supervised for proper connection and voltage when using an RJ38X. With the RJ38X and the D161 phone cord connector installed, terminal 10 is a ground reference which can be wired in series with a D105BL resistor and connected to a protective zone input. When the phone cord is removed from the RJ38X, the protective zone is faulted (opened). See Figure 7 for wiring diagram.

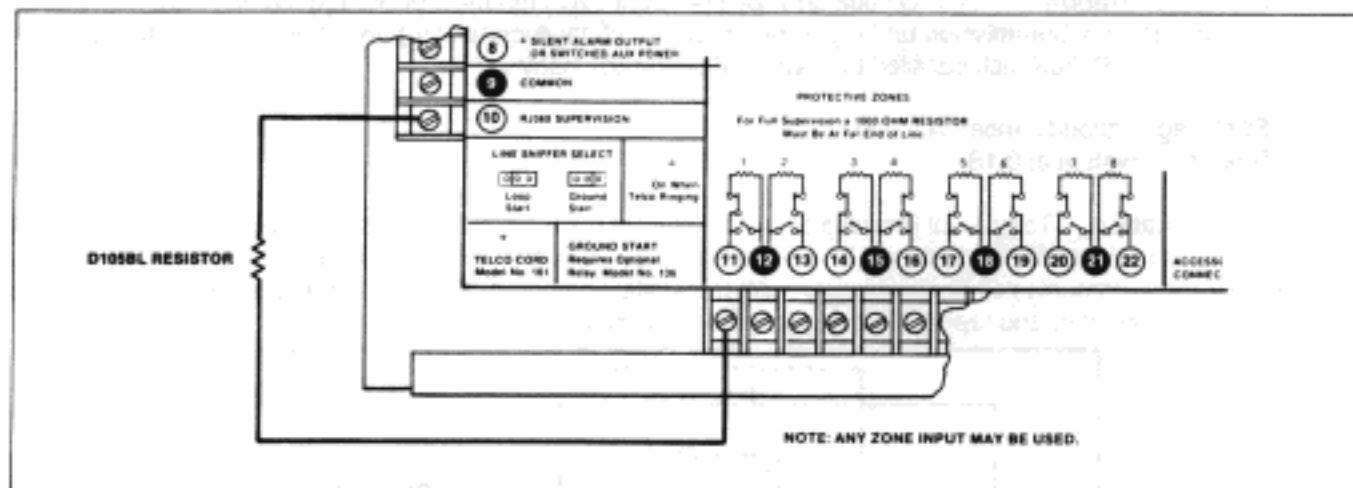

Figure 7. RJ38X Supervision Wiring Diagram

## 9. Telephone Circuit Parameters

- 9.1 **Ground Start** - Some telephone systems require a momentary ground input to initiate dial tone. To interface with a ground start system, a plug-in relay must be inserted into socket K5 and the Line Sniffer Select jumper (ground start/loop start) should be on the pins shown in Figure 8. The Communicator must be connected to an earth ground reference for the ground start system to function correctly. The RJ31X or RJ38X should be installed on the street side of the phone switch, wired ahead of any PBX equipment.

**IMPORTANT NOTE:** Ground Start telephone systems cannot be used for NFPA 71 Central Station Protective Signaling or NFPA 72C Remote Station applications.

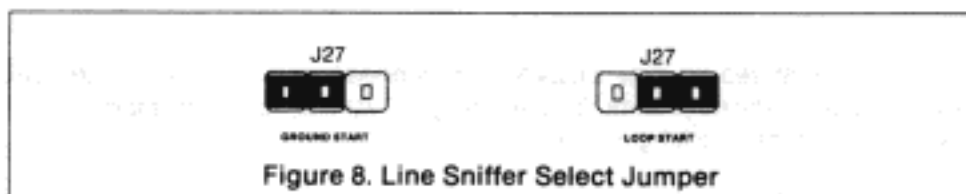

Figure 8. Line Sniffer Select Jumper

- 9.2 **Telephone Line Sniffer** - The D8112 Control/Communicator has a built-in phone line monitor that tests the telephone line every 60 seconds. The normal voltage on a telephone line is approximately 48 VDC. If that voltage drops below 20 to 30 VDC, and there is not a corresponding 15 to 20 mA current increase, the monitor senses trouble. The detection circuit then tests the line more frequently until the trouble delay time (see 8112:MAIN Program Entry Guide, item #11 PhSupv) is equalled. The trouble delay time tells the Control/Communicator how long to test a trouble condition before it responds to that condition.

**NOTE:** The telephone line monitor uses voltage and current levels to test the status of the phone line. In some instances a given telephone line may be out of service while the voltage on that line is not affected. The D8112 Control/Communicator would not recognize this trouble condition.

- 9.3 **Dual Line Transmitting** - By connecting the optional Dual Phone Line Module (Radionics model D128), the D8112 Control/Communicator can transmit messages on two separate telephone lines. Program item #13 2Line "Yes" if using this option.

- 9.4 **TelCo Ring Light** - The faceplate/lightning shield has an opening on the bottom left corner for viewing the TelCo ring detector light. This light should be "on" when the subscriber telephone is ringing.

## 10. The Protective Zones

Terminals **11** **12** **13** **14** **15** **16** **17** **18** **19** **20** **21** **22**

- 10.1 Description** - The D8112 Control/Communicator has eight separate protective zones. Each zone functions independently and does not interfere with the operation of the others. When wiring these zone inputs a resistor (Radionics model D105FL for fire loops or D105BL for non-fire loops) must be installed at the far end of the loop to provide a reference for supervision. Dry contact sensing devices may be connected in series (normally closed) or in parallel (normally open) to any of these loops.

**NOTE:** The possibility of "ground shunts" increases significantly if the resistor is not installed at the end of the line.

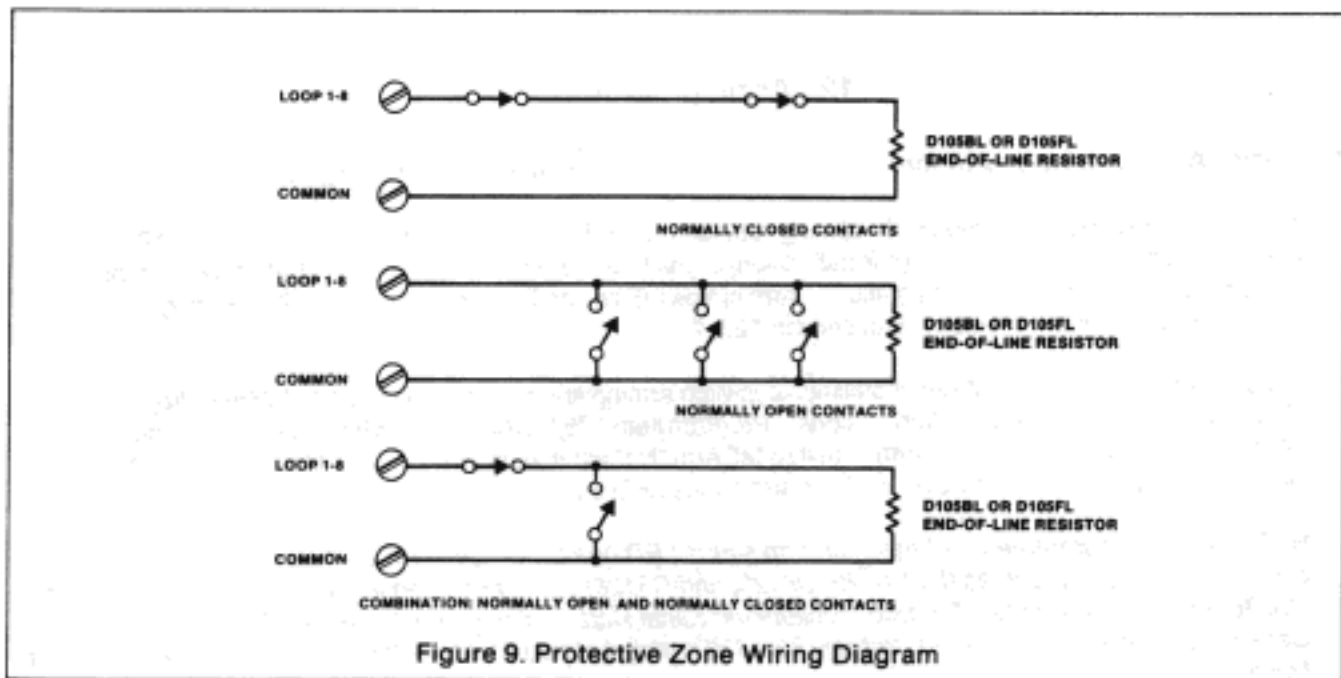

- 10.2 Protective Zone Parameters** - To supervise the protective zones, the D8112 Control/Communicator responds to a normal, shorted, or open condition between a zone input terminal (11, 13, 14, 16, 17, 19, 20, and 22) and any of the zone common terminals (12, 15, 18, and 21). The parameters which determine the condition of the zone are listed below.

You can determine the condition of any zone by measuring the voltage across the terminals. Loops must be connected, and the end-of-line resistor must be in place.

Normal Loop = Voltmeter reading greater than 2.0 VDC but less than 3.0 VDC.

Shorted Loop = Voltmeter reading less than 1.3 VDC.

Open Loop = Voltmeter reading greater than 3.7 VDC.

**10.2.1 Loop Response Time** - The D8112 Control/Communicator checks the protective loops every 100 millisecond. A loop must be in an abnormal condition on two successive checks to be recognized as a violated zone. (This precaution reduces false alarms.) Therefore loop response time is rated at 100 to 200 millisecond.

## 11. Zone Expansion and Sync

### 11.1 Zone Expansion

Terminals

27 28

The function of terminals 27 and 28 (Zone Expander) is described in the following *Omegalarm Zone Expansion Manuals: D8125 POPEX and D8126 POPIT Operation and Installation Manual*, (part no. 74-04247-000) and *D8128 OctoPOPIT Operation and Installation Manual* (part no. 74-04416-000). Zone expansion is only available with D8112G series Control/Communicators.

### 11.2 Sync

Terminal

25

Terminal 25 (Sync) is not used.

## 12. Arming Stations

### 12.1 Master Arm (Keyswitch Arming)

Terminals

26 29

**12.1.1 Application** - Keyswitch arming stations can be used to arm/disarm the D8112 Control/Communicator. Use momentary (normally open) or maintained closure keyswitches, but not both in the same system, to operate these arming stations. Arm status LED's can be remoted to keyswitch arming stations by special programming as described in section 12.1.2.

**12.1.2 Programming** - When installing keyswitch arming stations, consult the *D8112:MAIN Program Entry Guide*, section 12. "Arming Station Options." Program item #78 MCArm "Yes" when using maintained closure keyswitch arming stations. Program item #78 MCArm "No" when using momentary closure keyswitch arming stations. Program item #79 LED "Yes" for arm status LED output.

**NOTE:** When programmed for keyswitch arm status LED output, *Omegalarm Command Centers and other Serial Data devices (such as the D8129, D8125, and D8128) cannot be used in the system. The Operation Monitor LED on the D8112 I/O board monitors the Serial Data exchange between the CPU board and Serial Data output (Terminal 31). When Program item #79 is programmed "Yes" the Operation Monitor LED does not flicker.*

**12.1.3 Installation** - Install the keyswitch wiring across terminals 26 and 29 as shown below.

Arm status LED wiring is installed across terminals 31 and 29 as shown below. A current limiting resistor (Radionics model D105BL) is installed in series with the circuit.

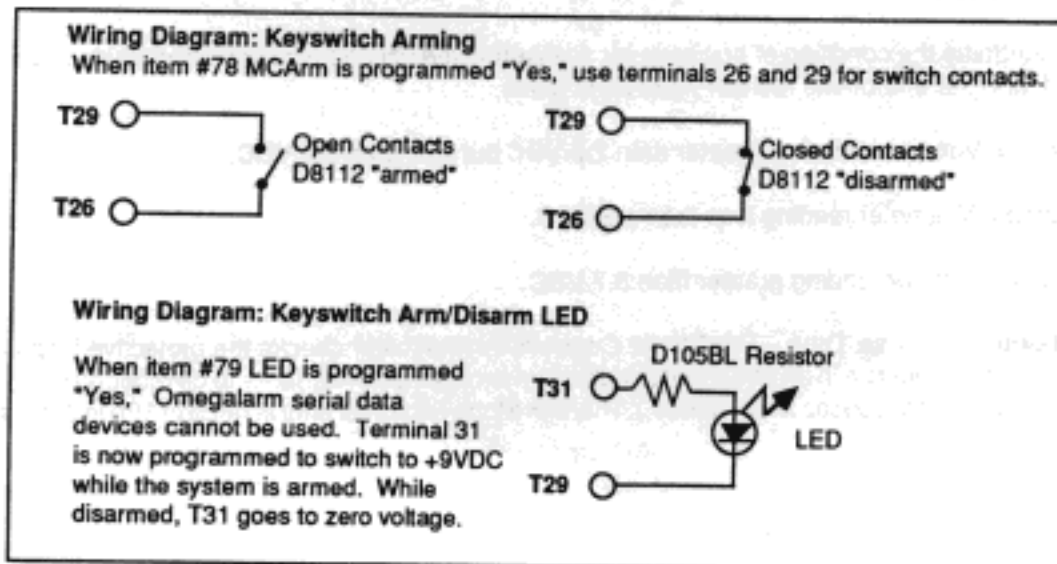



## 12.2 Omegalarm Serial Data Command Centers Terminals

**12.2.1 Application** - Four wire Command Centers are used to arm/disarm controlled zones, announce complete system status, initiate system tests, and control many features of the D8112 security system. Arm/disarm combinations, entry/exit delay times, prewarning buzzer output, and other Command Center functions are programmed into the D8112. Consult the *8112:MAIN Program Entry Guide*, sections 9 through 17, and the *8112:AUX Program Entry Guide (Command 5's Subhandler)* for the options available to the powerful Omegalarm Command Centers. Consult the appropriate Command Center User's Guide for detailed operation specifications.

**12.2.2 Master Arming** - To arm all controlled zones (24 hour zones are always armed) enter the arm/disarm combination or Command 1. If all controlled zones are normal the Command Center indicates that exit delay time has started. When the exit delay expires, the system arms. If a controlled zone is faulted when attempting to master arm, the Command Center buzzer sounds and the system will not arm. (See paragraph 12.3 Force Arming). When a delayed zone is faulted after arming, the warning buzzer latches on to remind the user to disarm the system. Enter the arm/disarm combination to disarm the system.

**12.2.3 Perimeter Arming** - Perimeter arming is a programmable feature of the D8112 security system. Perimeter arming allows you to arm only those zones programmed as perimeter zones, while other sections remain unarmed. Perimeter arming can be instant or delayed. See the *8112:MAIN Program Entry Guide*, sections 13 and 14.

**12.2.4 Panic/Emergency** - The Omegalarm D8112 can be programmed to generate panic alarms, silent duress alarms and two emergency codes by entering special combinations and command codes at the Command Center.

**12.2.5 System Status Display** - The Omegalarm D360 Command Center uses an LED display to show system status and zone conditions. The Omegalarm D1252 Alpha II Command Center contains a sixteen character vacuum fluorescent display to announce system status conditions in an English language format. See the appropriate Command Center manual for detailed descriptions.

**12.3 Force Arming** - Force arming is a programmable function which allows the system, or part of the system to be armed when zones are not normal or "ready." The zones which are not normal can be overridden by the arming procedure and will NOT detect violations. All other zones operate as programmed. (For more information on Force Arming Options available with each model of the D8112, see the *8112:MAIN Program Entry Guide*.)

The parameters for force arming are as follows:

1. Any controlled zone may be force armed except "priority" zones. The D8112 security system cannot be armed while a priority zone is faulted.
2. Swinger shunt zones can be force armed, however, if a swinger shunt zone is restored after arming it is returned to the protective circuit and will detect faults and initiate alarms.
3. 8112:MAIN Item #87 FAMax controls the number of faulted zones allowed to be shunted when force arming. (i.e. if #87 FAMax is programmed as 4, a maximum of four zones can be shunted while force arming.)
4. Force arming can be initiated with the arm/disarm combination or with various arming commands. To force arm using arming commands see section 13 and 14 in the *8112:MAIN Program Entry Guide*.

**12.3.1 Reports** - When force armed, the D8112 reports zones shunted by the arming procedure as "ZONE TROUBLE." This report is accompanied by a "CLOSING REPORT" if the D8112 is programmed for opening/closing. In addition, if the D8112 is transmitting reports using the BFSK or Modem II format, a standard header message will appear with all force arming reports. The header is displayed as "WAS FORCE ARMED."

**12.4 Selective Zone Shunting** - When using Omegalarm Command Centers, D8112 controlled zones can be selectively shunted when arming. Only non-priority controlled zones can be shunted. Selective zone shunting is used while the D8112 is in an exit delay mode. See the appropriate Command Center manual for details of this feature.

## 12.5 Optional Serial Data Equipment Connections to Terminal

31

In addition to the system's control centers, terminal 31 is used to connect several optional serial data devices to the D8112. To ensure that the strength of the serial data output is adequate to support all serial data devices connected to terminal 31, check the charts below. If the number of devices exceeds the number allowed to be connected to the D8112's terminal 31, a D8114 Quad Serial Output Module can be installed to supplement the output available. The D8114 provides four isolated data output terminals to prevent interference between serial data devices connected to terminal 31 (see the *D8114 Operation and Installation Instructions* for additional important information when using this module).

D8112 Terminal 31			D8114 Quad Serial Output Module		
Device	Max. # of Units	Max Wire Length (feet) Total (22 or 18 AWG)	Max. # of Units With D8114	Max. # of Units Per Terminal 31*	Max Wire Length (feet) Total (22 or 18 AWG)
D1252/360	5	500	10	5	1000
D8125	2 (63 POPITs ea.)	Installed at Panel	2 (63 POPITs ea.)	2	Installed at Panel
D8128	16	Installed at Panel	16	16	200
D8129	3 - 5 *	200	8	8	200
D8220	4 (D8114 Recommended)	500	8	8	500
D8225	N/A (D8114 Required)		4	4	1000
* When combining Command Centers with D8129s on terminal 31, subtract one Control Center for each D8129 in excess of 3.			*Combining different types of devices on the same D8114 terminal 31 is not recommended (exceptions: D8125 & D8128 modules can be combined subject to Zonex programming restrictions, and D8220 & D8225 card readers can be combined, up to 8 units total). See D8114 Manual for additional guidelines.		

## 13. Accessory Connector Points

**13.1 Accessory Connector (J26)** - The Accessory Connector is located on the bottom right corner of the I/O board. This connector is used to connect the Omegalarm D8112 to interface modules designed for alternate methods of signal and system data output. Two examples are the D128 Dual Phone Line Switcher and the D8131 Printer/CRT Interface Module. The D128 allows the D8112 to use two separate telephone lines for transmitting reports to an alarm central station. The D8131 allows the D8112G2 or D8112A to connect to an on-premises event logging printer, or CRT. (For installation, operating instructions, and compatibility requirements, consult the instruction manual provided with the accessory.)

**13.2 E.A.R. Connector (J24)** - The E.A.R. Connector is located on the bottom right corner of the I/O board. This connector is used to interface the Omegalarm D8112 with the D180A Listen-In Amplifier. The D180A can be connected to up to six (6) audio pick-up microphones with a four conductor cable. This system allows the central station to listen-in to an event taking place at the protected premises.

**13.2.1 Programming** - When using the D180A Listen-In Amplifier, program 8112:MAIN item #76 Listen for listen-in time.

## 14. Programmer &amp; Test Connector

The Omegalarm D5100B Bar Code Programmer must be connected to the D8112 Control/Communicator while copying and loading programs, or running the Loop Test Program. This connection is made at the Programmer & Test Connector (J2) located on the top right corner of the I/O board.

1. Plug the D5100 Data/Power cord into the Programmer & Test Connector (J2).
2. Advance the D5100 display to a D8112 program file. (See *D5100 Bar Code Programmer Operation Manual*).
3. Momentarily short terminal 32 (Disable/Restart) to terminal 29 (Common).
4. Perform the desired programming function (i.e. load or copy program).

**NOTE:** While the Control/Communicator is addressing the Programmer, all control, detection and transmitting functions of the system are inoperable. If the Programmer repeatedly displays "Reset 8112", disconnect all connections to terminals 30 and 31.

## 15. Quick Reference Terminal Description

Terminal	Function	Description
1 & 2	AC Input	Requires 16.5 VAC 40 VA transformer.
3 (+)	Auxiliary (AUX) Power	Supplies 1 Amp at 10.2 to 14VDC to auxiliary devices. Use T9 for ground reference.
4 (-)	Earth Ground & Battery Negative (-)	T4 connects to negative side of the battery. Also used for earth ground connection (cold water pipe).
5 (+)	Battery (+)	Connect 12V 6AH rechargeable lead acid type battery. (+) side to terminal 5 and (-) side to terminal 4.
6 (+) 7 (+)	Alarm Power Outputs	T6 and T7 supply 2 Amps at 10.2 to 14 VDC on alarm. Use T9 for ground reference. <b>NOTE:</b> T7 requires plug-in relay (K6). Output dependent on programming.
8(+) (Terminal 8 can be either of the following, selectable by plug-in relay in K7 or K8.)	Silent Alarm Power Output —OR— Switched Auxiliary Power	Silent Alarm (K7) - Supplies 2 Amps at 10.2 to 14VDC on silent alarms only. —OR— Switched AUX power (K8) - Continuous 1 Amp at 10.2 to 14VDC, circuit can be reset from Command Center (Command 47).
9 (-)	Power Common	T9 is used for AUX and Alarm Power common (ground).
10(+)	RJ38X Jack Supervision	Connect to zone input for phone cord supervision.
11, 13, 14, 16 17, 19, 20, 22	Protective Zone Inputs	Connect normally open and/or normally closed detection devices to loop wiring.
12, 15, 18, 21	Zone Common	Loop return for protective zones.
23(-) 24(-)	System Common	T23 and T24 are system common (ground) connections.
25	Sync	Not Used.
26	Master Arm	Use T26 as an arming input for momentary or maintained contact switches.
27 & 28	Zone Expander	Serial Data Input used with Zonex (Zone Expansion) Systems (D8112G series only) OR with Access Control System components (D8112A series only).

**Omegalarm Command Center Connections** (These terminals are also used for other Serial Data devices. See the instruction manuals provided with the equipment.)

29(-)	Common	T29 is power ground for Command Center. Connect BLACK wire.
30	Serial Data In	T30 is connected to Command Center GREEN wire.
31	Serial Data Out	T31 is connected to Command Center YELLOW wire.
3(+)	Auxiliary Power	T3 is used to power (+VDC) the Command Center. Connect RED wire.
32	Disable/Restart	When connected to system common the D8112 is disabled.

## 16. Installation Guide for U.L. Certificated Systems and Fire Alarm Applications

The "Omegalarm D8112 System Chart" references components which have been evaluated and listed by Underwriters' Laboratories for electrical compatibility with D8112 Control/Communicators. Where required for a particular application, these components meet the basic system requirements for the applicable standard.

The wiring diagram in Figure 10 shows the relationship between the D8112 Control/Communicator and the accessory components referred to in the "System Chart." For more detailed instructions on the installation and operation of these components, see the installation document listed for the component on the "System Chart."

### 16.1 Optional Compatible Equipment

U.L. Listed components which do not require evaluation for electrical compatibility can also be used in many applications when installed according to the manufacturer's instructions.

**16.1.1 Burglary Applications** - All types of U.L. Listed burglar alarm sensors which *do not require evaluation for electrical compatibility* can be used in burglary applications. In some cases a U.L. listed Omegalarm interface must be used in conjunction with the sensors. Consult the individual component specification and installation documents to determine suitability.

**16.1.2 Fire Applications** - U.L. Listed fire initiating devices not requiring electrical compatibility evaluation may be used in any application. For example: Heat detectors, waterflow switches, manual pull stations and four-wire smoke detectors are suitable fire initiating devices. Consult the individual component specification and installation documents to determine suitability. A suitable circuit interface module must be used when connecting fire alarm initiating devices to the D8112. In compliance with U.L. listing standards, the total power output for the system during alarm conditions is limited to 1400 mA, unless a D8132 Battery Charger Module is connected to the D8112. (See Column C of the *D8112 Communicator Standby Battery and Current Rating Chart*.)

**16.1.3 Circuit Interface Equipment** - All types of initiating devices (except 2-wire smoke detectors, see note below) can be connected to the D8112 through EITHER the D129 Dual Class A Initiation Circuit module OR the D125 Powered Loop Interface OR through the D8125/D8126 Zonex System. (Zonex requires a D8112G series control/communicator.) When using four-wire smoke detectors, a suitable power supervision unit must be installed according to the manufacturer's instructions. An Omegalarm D136 Relay must be installed in the D8112 Control/Communicator to provide reset capability.

**Note:** Two-wire smoke detectors must be connected to the D8112 through the D125 Powered Loop interface (connection to the D129 or Zonex system is not acceptable). An Omegalarm D136 Relay must be installed in the D8112 Control/Communicator to provide reset capability. Two-wire detectors must be evaluated for electrical compatibility, and must be U.L. listed for use with the D8112. To determine if a particular two-wire smoke detector is U.L. listed for use with the D8112 see Radionics Technogram #73-05510-000, or you may contact the detector manufacturer.

**16.1.4 Enclosures** - Radionics offers three enclosure models for the D8112 Control/Communicator:

**The D8103 enclosure** is suitable for residential fire and/or burglary installations and commercial applications which do not require attack resistance or approval by Factory Mutual. (See the "Omegalarm D8112 System Chart" for acceptable applications.)

**The D8108A** is attack resistant. It is intended primarily for U.L. Certificated Central Station, Local, and Police Connected burglar alarm applications. The D8108A may also be used in any burglar or fire alarm application where the D8103 or D8109 enclosure is suitable. The D8108A is U.L. listed for NFPA 71 Central Station, NFPA 72A Local, NFPA 72C Remote Station, and NFPA 74 Household Warning systems. The D8108A is approved by Factory Mutual, California State Fire Marshal, and the New York City Board of Standards and Appeals.

**The D8109** is intended for commercial fire alarm applications (NFPA 71, 72A, and 72C), but it may also be used for residential applications. The D8109 is U.L. listed for NFPA 71 Central Station, NFPA 72A Local, NFPA 72C Remote Station, and NFPA 74 Household Warning systems. The D8109 is approved by Factory Mutual, California State Fire Marshal, and the New York City Board of Standards and Appeals.

# Omegalarm D8112 System Chart

Application:	NFPA Standard (1)	Min. Bat. Standby Hours (2)	Enclosure	Arming Stations		Circuit Modules		Smoke Detectors		Reversing Relay	Dual Phone Line	Bell Cr. Supervision	D268/D269 Ind. Zone Control	Miscellaneous Equipment Requirements	Optional Modules (Suitable for use in all applications)
				D360 Command Center	D1252 Command Center	D125	D129	2-wire (4)	4-wire Any 12VDC Model						
Household Burglary	---	4	D8103 or D8109	Choice Required	OP	NA	OP	NA	NA	SP	SP	SP	OP	85 dBA Listed Audible Device(s)	D8114 Quad Serial Output Module (74-04984-000)
Household Fire	74	24 hrs + 4 minute alarm	D8109 or D8108A	Choice Required	Choice Required	Choice Required	Choice Required	Choice Required	Choice Required	NA	SP	SP	NA	85 dBA Listed Audible Device(s)	D8131 Printer/CRT Interface Module (74-04739-000)
Household Fire/Burg. Combination	74	24 hrs + 4 minute alarm	D8108A	Choice Required	Choice Required	Choice Required	Choice Required	Choice Required	Choice Required	SP	SP	SP	OP	For Grade B: D8108A & Listed Bell Housing	D8129 Octafirey Module (74-04582-000)
Central Station Burglary (Grade C)	---	4	D8108A	Choice Required	Choice Required	Choice Required	Choice Required	Choice Required	Choice Required	NA	R	SP	NA	Listed Audible Device(s)	D8132 Battery Charger Module (74-04777-000)
Central Station Fire	71	24	D8109	OP	OP	OP	OP	OP	OP	NA	R	SP	NA	Listed Audible Device(s)	
Comb. Local & Central Sta. Fire	72A	24 hrs + 5 minute alarm	D8109	OP	R	Choice Required	Choice Required	Choice Required	Choice Required	NA	R	R	NA	Listed Audible Device(s)	
Central Station Fire/Burg. Comb.	71	24	D8109	OP	OP	Choice Required	Choice Required	Choice Required	Choice Required	SP	R	SP	NA	Listed Audible Device(s)	
Comb. Local & Central Sta. Fire/Burg.	72A	24 hrs + 5 minute alarm	D8108A	OP	R	Choice Required	Choice Required	Choice Required	Choice Required	OP	R	R	NA	Listed Audible Device(s)	
Local Fire	72A	24 hrs + 5 minute alarm	D8108A	OP	R	Choice Required	Choice Required	Choice Required	Choice Required	OP	R	R	NA	Listed Audible Device(s)	
Electrically Actuated Transmitter	71	24	D8108A	OP	OP	SP	SP	NA	NA	NA	R	NA	NA	Listed Audible Device(s)	
Remote Station Fire	72C	60 hrs + 5 minute alarm	D8108A	OP	OP	Choice Required	Choice Required	Choice Required	Choice Required	OP	R	SP	NA	Listed Audible Device(s)	
Local Fire & Burg. Combination	72A	24 hrs + 5 minute alarm	D8108A	OP	R	Choice Required	Choice Required	Choice Required	Choice Required	OP	R	SP	OP	Listed Audible Device(s)	
Police Connected Burglary	---	4	D8108A	Choice Required	Choice Required	OP	OP	NA	NA	OP	SP	SP	OP	Listed Audible Device(s)	
Local Burglary	---	4	D8108A	Choice Required	Choice Required	OP	OP	OP	OP	OP	SP	SP	OP	Listed Audible Device(s)	
<p>Note: This chart references components which have been evaluated and listed by UL for electrical compatibility.</p>															

**LEGEND**

- R - Required
- OP - Optional
- NA - Not Acceptable in System
- N/A - Not Acceptable for Fire Zones
- SP - Special Applications (Not Normally required in this application)

(1) The D8112 is programmed using an Omegalarm 5100 Bar Code Programmer. The 78112 System Compliance Verification Manual provides guidelines to follow to program the unit for the given application. For Program Checklist, see 78112 System Compliance Verification Manual P/N 74-04178-000. The manual also references a method that can be used by inspection authorities to verify that correct program entries have been made for the application.

(2) Battery requirements for standby power can be determined from the Battery Chart in this manual.

(4) Two-wire smoke detector devices must be evaluated for electrical compatibility with the D8112, and must be U.L. listed for use with the D8112. Contact the smoke detector manufacturer to determine if the detector is listed for that purpose.

For Op & Inst rev G @2/2/89  
revised 1/30/90 for rev. G 1/90 (D192A)

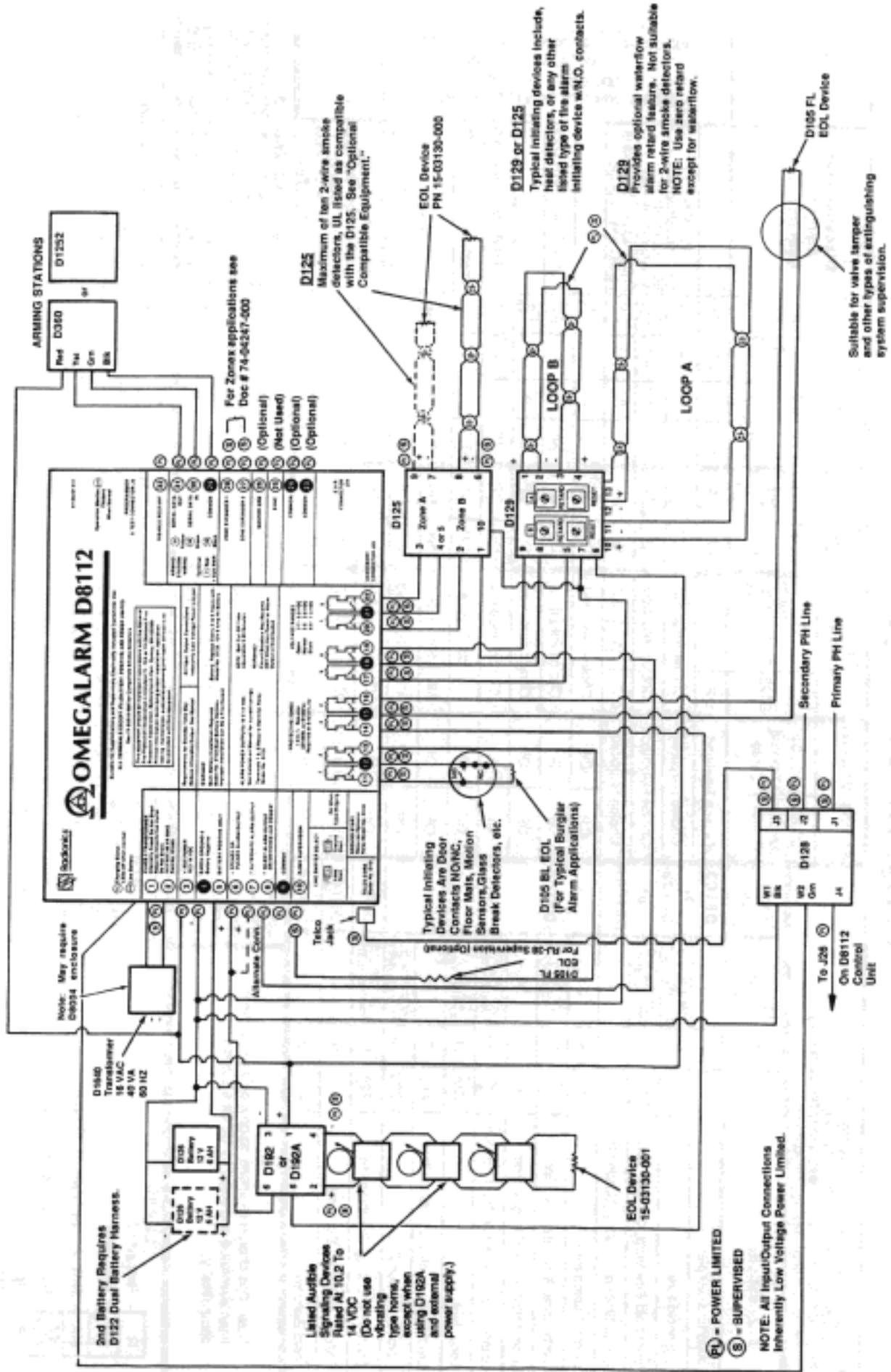

## 16.2 Battery Standby Calculations for Fire Alarm Applications

The "8112 Communicator Standby Battery and Current Rating Chart" provides guidelines for calculating the system's current requirements and outlines standby power requirements for the various standards.

**16.2.1 Central Station (NFPA 71) Systems** require 24 hours of standby battery capacity. Two batteries may be required in the D8112 system to meet the basic standby requirements for an NFPA 71 installation. To verify compliance with NFPA 71 you only need to add the current values listed in column B (AC Power Off) and confirm that this total does not exceed 225 mA (one battery) or 450 mA (two batteries).

An alternate means of verifying compliance with standby battery requirements for NFPA 71 systems is to use the formula shown below to determine the ampere hour (A.H.) requirements of the system as related to the ampere hour capacity of the batteries. Note that the formula includes a 10<sup>0</sup>% contingency factor. This factor makes allowance for depletion of battery capacity with age.

### FORMULA FOR NFPA 71 AMPERE HOUR CALCULATION:

$$\frac{\text{Column B Total}}{\text{Total}} \times 24 \text{ Hours} + \frac{10^0\%}{\text{Contingency Factor}} = \text{Total A.H.}$$

Total A.H. requirements must not exceed A.H. capacity of batteries: One D126 Battery = 6 A.H.  
Two D126 Batteries\* = 12 A.H.

**16.2.2 NFPA 72A Local Systems** require 24 hours of standby plus 5 minutes of alarm operation at the end of the 24 hour period. Two batteries must be installed in the D8112 system to meet the basic standby requirements for an NFPA 72A installation. You must use battery ampere hour (A.H.) calculations to verify compliance with NFPA 72A. The following formula includes the calculation for 5 minutes of alarm operation at the end of the 24 hour period, as well as a 10<sup>0</sup>% contingency factor which allows for depletion of battery capacity with age.

### FORMULA FOR NFPA 72A AMPERE HOUR CALCULATION

$$\frac{\text{Column B Total}}{\text{Total}} \times 24 \text{ Hours} + \frac{\text{Column C Total}}{\text{Total}} \times \frac{1}{12} \text{ (5 min.)} + \frac{10^0\%}{\text{Contingency Factor}} = \text{Total A.H.}$$

Total A.H. requirements must not exceed A.H. capacity of batteries: Two D126 Batteries\* = 12 A.H.

**16.2.3 NFPA 72C Remote Station Systems** require 60 hours of standby plus 5 minutes of alarm operation at the end of the 60 hour period. A D8132 Battery Charger Module with additional batteries installed in a separate D8109 or D8108A enclosure may be required in the D8112 system to meet the basic standby requirements for an NFPA 72C installation. You must use battery ampere hour (A.H.) calculations to verify compliance with NFPA 72C. The following formula includes the calculation for 5 minutes of alarm operation at the end of the 60 hour period, as well as a 10<sup>0</sup>% contingency factor which allows for depletion of battery capacity with age.

### FORMULA FOR NFPA 72C AMPERE HOUR CALCULATION

$$\frac{\text{Column B Total}}{\text{Total}} \times 60 \text{ Hours} + \frac{\text{Column C Total}}{\text{Total}} \times \frac{1}{12} \text{ (5 min.)} + \frac{10^0\%}{\text{Contingency Factor}} = \text{Total A.H.}$$

Total A.H. requirements must not exceed A.H. capacity of batteries: Two D126 Batteries\* = 12 A.H.

**16.2.4 Household Fire Warning (NFPA 74) Systems** require 24 hours of standby plus 4 minutes of alarm operation at the end of the 24 hour period. You must use battery ampere hour (A.H.) calculations to verify compliance with NFPA 74. The following formula includes the calculation for 4 minutes of alarm operation at the end of the 24 hour period, as well as a 10<sup>0</sup>% contingency factor which allows for depletion of battery capacity with age.

### FORMULA FOR NFPA 74 AMPERE HOUR CALCULATION

$$\frac{\text{Column B Total}}{\text{Total}} \times 24 \text{ Hours} + \frac{\text{Column C Total}}{\text{Total}} \times \frac{1}{15} \text{ (4 min.)} + \frac{10^0\%}{\text{Contingency Factor}} = \text{Total A.H.}$$

Total A.H. requirements must not exceed A.H. capacity of the battery: One D126 Battery = 6 A.H.  
Two D126 Batteries\* = 12 A.H.

\* When connecting two batteries, use EITHER the D122 Dual Battery Wiring Harness OR the D8132 Battery Charger Module.

## Instructions for Connection of D8112 to Morse PAL-200C to Comply with U.L. AA Certification

### NOTES:

- ① TS2 and TS3 jumpers must be set in the positions shown.
- ② All unused alarm inputs (terminals 1-8) must be connected to Ground.
- ③ The D8112 must be programmed to send Opening and Closing signals to and receive Ringback signals from the Central Station receiver. (Program line 74 TsBel YES.)
- ④ The PAL-200C includes a U.L. listed enclosure.
- ⑤ The Voltage Translator section shown on page 9, figure 3 of the PAL-200 Installation and Operating Instructions (Morse document no. 3440-0160 Rev. B or higher) must be used if the off hook voltage falls below 3.5 VDC.
- ⑥ Install enclosure and wiring as per PAL-200C Installation and Operating Instructions (Morse document no. 3440-0160 Rev. B, or higher).
- ⑦ Tip and ring wires from the RJ11 jack must be connected to terminals 5 (green) and 4 (red) respectively in the RJ31X jack to maintain continuity to the Pal-200C when the D8112 is communicating.

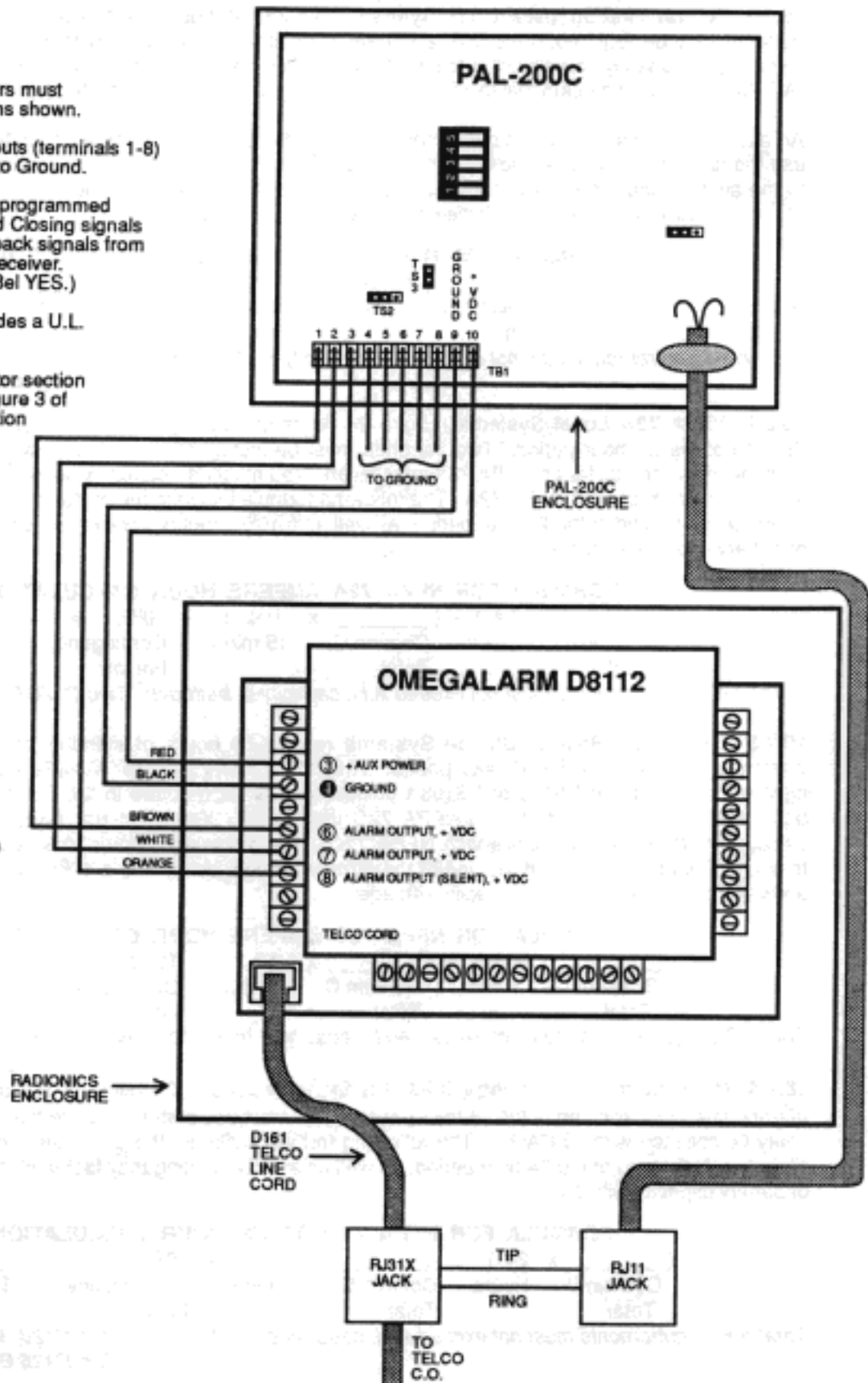



## D8112 Communicator Standby Battery and Current Rating Chart

Accessory Model	Quantity Used	AC Power On Normal Current		AC Power Off Minimum Current		In Alarm Maximum Current	
		Each Unit	Total System	Each Unit	Total System	Each Unit	Total System
		A		B		C	
D8112	1	150 x Quan. =	150	150 x Quan. =	150	250 x Quan. =	250
D125	_____	20 x Quan. =	_____	19 x Quan. =	_____	123 x Quan. =	_____
D127	_____	13 x Quan. =	_____	12 x Quan. =	_____	45 x Quan. =	_____
D128	_____	14 x Quan. =	_____	14 x Quan. =	_____	45 x Quan. =	_____
D129	_____	25 x Quan. =	_____	25 x Quan. =	_____	26 x Quan. =	_____
D192A	_____	15 x Quan. =	_____	15 x Quan. =	_____	50 x Quan. =	_____
D360	_____	30 x Quan. =	_____	26 x Quan. =	_____	107 x Quan. =	_____
D1252	_____	104 x Quan. =	_____	106 x Quan. =	_____	206 x Quan. =	_____
D8114	_____	14 x Quan. =	_____	13 x Quan. =	_____	14 x Quan. =	_____
D8125	_____	48 x Quan. =	_____	47 x Quan. =	_____	48 x Quan. =	_____
D8126U	_____	3 x Quan. =	_____	3 x Quan. =	_____	4 x Quan. =	_____
D8128	_____	27 x Quan. =	_____	27 x Quan. =	_____	46 x Quan. =	_____
D8129	_____	5 x Quan. =	_____	5 x Quan. =	_____	5 x Quan. + 25 x # relays =	_____
D8130	_____	5 x Quan. =	_____	5 x Quan. =	_____	54 x Quan. =	_____
D8131	_____	24 x Quan. =	_____	22 x Quan. =	_____	36 x Quan. =	_____
M801, 2, 3	_____	0 x Quan. =	0	0 x Quan. =	0	60 x Quan. =	_____
M806	_____	0 x Quan. =	0	0 x Quan. =	0	100 x Quan. =	_____
<b>Ratings of other devices in the system which are not shown above:</b>							
_____	_____	_____ x Quan. =	_____	_____ x Quan. =	_____	_____ x Quan. =	_____
_____	_____	_____ x Quan. =	_____	_____ x Quan. =	_____	_____ x Quan. =	_____
_____	_____	_____ x Quan. =	_____	_____ x Quan. =	_____	_____ x Quan. =	_____
_____	_____	_____ x Quan. =	_____	_____ x Quan. =	_____	_____ x Quan. =	_____
		<b>Column A</b>		<b>Column B</b>		<b>Column C</b>	
		<b>Total</b>	= _____	<b>Total</b>	= _____	<b>Total *</b>	= _____

\* If the Column C total exceeds 1400 mA, a D8132 is required in the system to provide an additional 1400 mA. In all cases the Total of each column above must not exceed the Limit for System Class shown below:

### Household Burglary

4 Hour Standby	One Battery	Limit = 1000	Limit = 1000	Limit = 1000
	Two Batteries	Limit = 1000	Limit = 1000	Limit = 2000

### Commercial Burglary

4 Hour Standby	One Battery	Limit = 1000	Limit = 1000	Limit = 1000
	Two Batteries	Limit = 1000	Limit = 1000	Limit = 2000

### Central Station Signaling Systems [(Fire) NFPA 71]

24 Hour Standby	One Battery	Limit = 1000	Limit = 225	Limit = 1400 (without D8132)
	Two Batteries	Limit = 1000	Limit = 450	Limit = 1400 (without D8132)

### Local Protective Signaling Systems [(Fire) NFPA 72A]

24 Hour Standby Plus 5 Minutes of Alarm Operation See Formula for NFPA 72A Ampere Hour Calculation.

### Remote Station Fire Systems [(Fire) NFPA 72C]

60 Hour Standby Plus 5 Minutes of Alarm Operation See Formula for NFPA 72C Ampere Hour Calculation.

### Household Fire Warning Equipment (NFPA 74)

24 Hour Standby Plus 4 Minutes of Alarm Operation See Formula for NFPA 74 Ampere Hour Calculation.

NOTE: ALL CURRENTS IN CHART ABOVE ARE IN MILLIAMPERES. (1 AMPERE = 1000 MILLIAMPERES)

10/1/80

Dear Sirs:

Reference is made to your letter of 10/1/80 regarding the above captioned matter.

The information requested is being furnished to you as follows:

1. The information requested is being furnished to you as follows:

2. The information requested is being furnished to you as follows:

3. The information requested is being furnished to you as follows:

4. The information requested is being furnished to you as follows:

5. The information requested is being furnished to you as follows:

6. The information requested is being furnished to you as follows:

7. The information requested is being furnished to you as follows:

8. The information requested is being furnished to you as follows:

9. The information requested is being furnished to you as follows:

10. The information requested is being furnished to you as follows:

Very truly yours,

\_\_\_\_\_  
 Director

10/1/80



1800 ABBOTT ST., P.O. BOX 80012, SALINAS, CA 93912-0012  
 TECHNICAL SUPPORT: (800) 538-5807



**O&I Menu**



**Documents by Type Menu**



**Documents by Product Menu**



**Main Menu**



Radionics