

# VIKING

# TECHNICAL Practice

TELECOM SOLUTIONS FOR THE 21ST CENTURY

**C-1000A**

**Door Entry  
Controller**

April 19, 2001

## Add Peripherals without Changing Your Phone System



doorboxes or paging amplifiers. In addition, the **C-1000A** provides two Touch Tone controlled relays to operate door strikes or gate openers.

## Features

- Allows two **Viking** doorboxes or paging amplifiers to share a single telephone line with a residential or business telephone system
- Custom ringing mode allows you to distinguish doorbox calls from C.O. calls
- Compatible with the following handsfree **Viking** models: **W-1000**, **W-2000A**, or **W-3000**
- Call waiting tones indicate which doorbox is calling and distinguish a doorbox call from a C.O. line call
- Calls can be placed on hold when visitors call from the doorbox or when paging
- Provides two Touch Tone controlled N.O. or N.C. dry contact closures (5 amp rating) for door strikes or gate openers
- Compatible with pulse or Touch Tone phones
- Postal lock/keyless entry input
- Built-in talk battery for "No C.O." applications
- Auxiliary contact output for doorbells, cameras, etc.



The **C-1000A** Controller dramatically expands the potential installation sites for many peripherals such as doorboxes and paging amplifiers.

Doorboxes and paging amplifiers can now be used on single line, residential or home office applications as well as on fully loaded systems, because they are no longer limited to installation on unused trunk ports.

The **C-1000A** allows single line phones or phone systems to share a phone line with one or two

## Applications

- Add one or two **Viking** Doorboxes to your home or office phones
- Add paging amplifiers to provide loud ringing and paging to businesses with single line phones or fully loaded phone systems
- Provide commercial or residential security via two-way handsfree communication from a door or gate
- Use as a line concentrator (one fax machine or answering machine can answer three lines)

Phone... 715.386.8861

info@vikingelectronics.com

http://www.vikingelectronics.com

## Specifications

**Power:** 120V AC/13.8V AC 1.25A, UL listed adapter provided  
**Dimensions:** 133mm x 89mm x 44mm (5.25" x 3.5" x 1.75")  
**Shipping Weight:** 0.9 kg (2 lb)  
**Environmental:** 0° C to 32° C (32° F to 90° F) with 5% to 95% non-condensing humidity  
**Door Strike Relay Contacts:** 5A @ 30V DC/250V AC maximum  
**Auxiliary Relay Contacts:** .5A @ 125V AC, 1A @ 30V AC  
**Connections:** (2) RJ11 jacks, (1) 12 position terminal block  
**Pulse Dialing Detection:** 10 pps  
**Talk Battery:** 30V DC  
**Maximum Doorbox Power Supply Length:** 100 ft, 24 awg wire

# Installation and Applications

## A. One or Two Doorboxes Sharing a Phone Line

See Operation, section A.

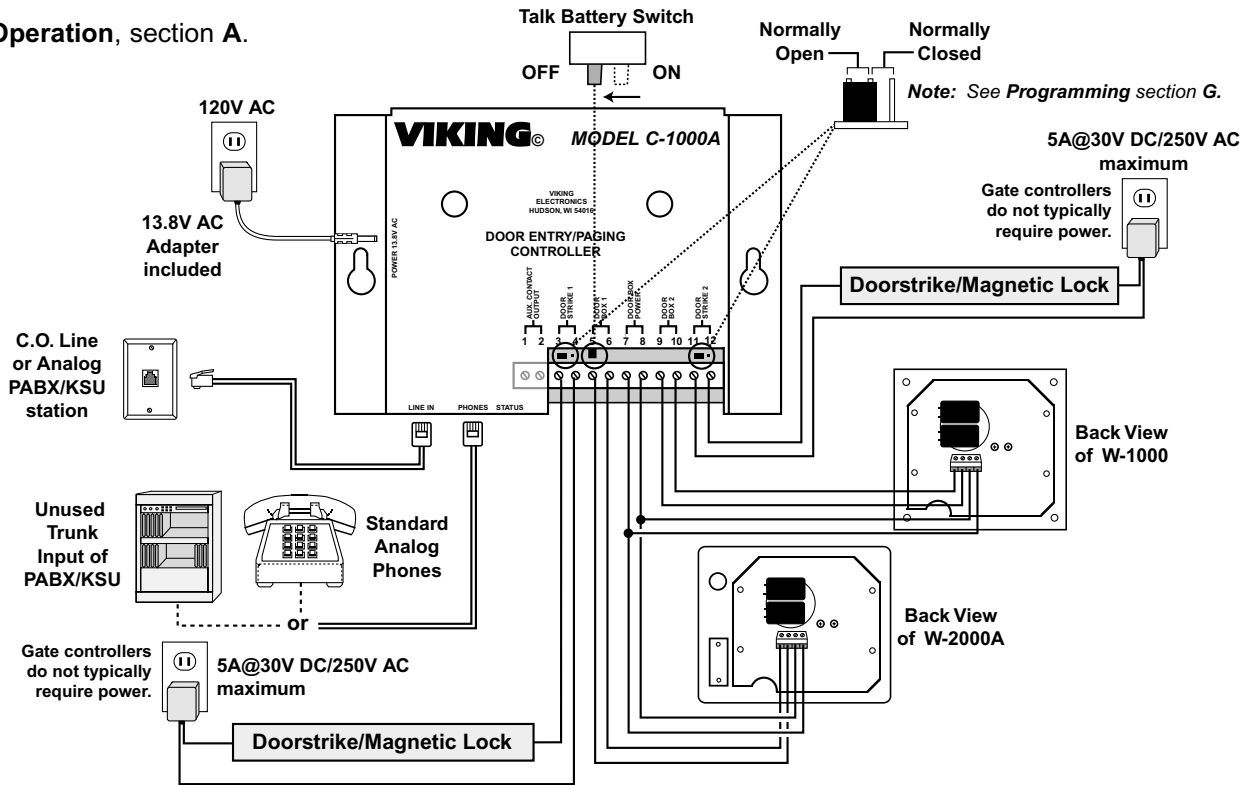

## B. Using the C-1000A with Three Doorboxes and No C.O. Line

The C-1000A can be used to control up to 3 doorboxes. If door/gate control is needed, the C-1000A must be used in combination with the RC-3 Remote Controller (Fax Back Document 165). In this configuration, the optional RC-3 is connected in parallel with doorbox 3 to provide up to three additional relay contacts. **Note:** Doorbox 3 will not have Touch Tone dialing restriction (security). Be sure to program the RC-3 and the C-1000A with different security codes.

See Operation, section A.

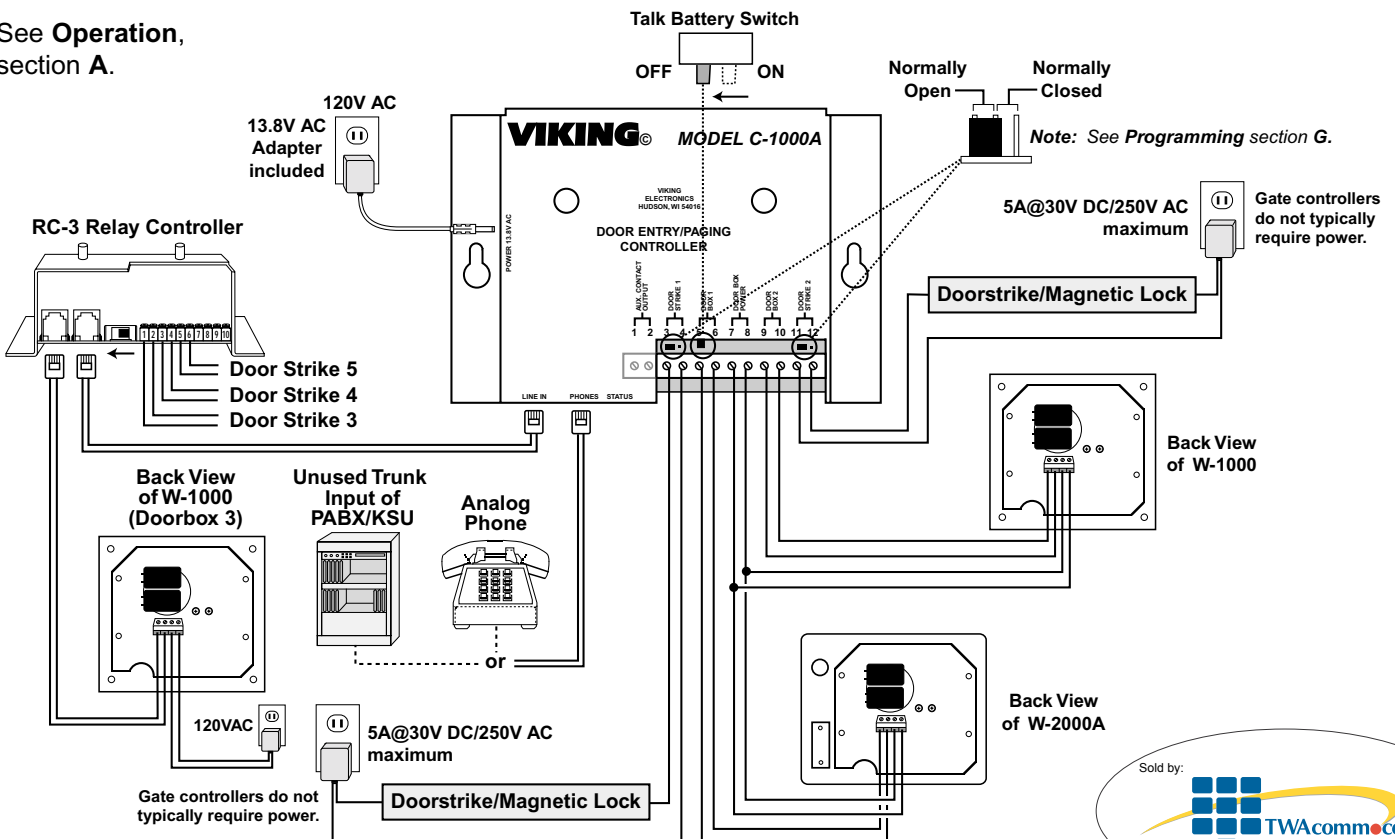

### C. Using a C-1000A without a C.O. Line

The **C-1000A** can also be used without a C.O. line. This is ideal for connecting the **C-1000A** to an unused trunk/line input of your phone system or connecting to phones used only for doorbox communication.

1. Connect the power, required doorboxes, and doorstrike outputs (if required) as shown in section **A**.
2. Connect an analog phone or PABX/KSU trunk port to the "PHONES" output of the **C-1000A**.
3. Be sure the "Talk Battery Switch" is in the **ON** position.

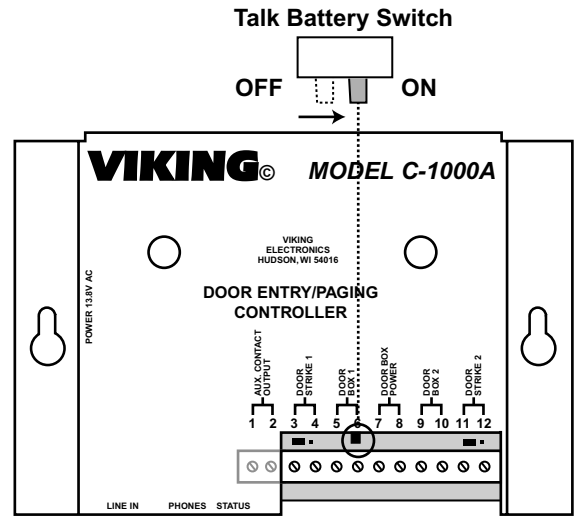

### D. Using the C-1000A with a Postal Lock/Keyless Entry

**Important:** Electronic components are sensitive to static electricity. Personnel and the work area should be grounded before handling.

1. Remove the **C-1000A** circuit board from the chassis.
2. Connect the postal lock to the two pin header **J5** at the rear of the board and replace circuit board in the chassis.
3. Connect doorboxes and doorstrike outputs (if required) as shown in section **A**.
4. See **Operation** section **A**, 5. **Postal Lock**.

International  
Electronics  
(800) 343-9502

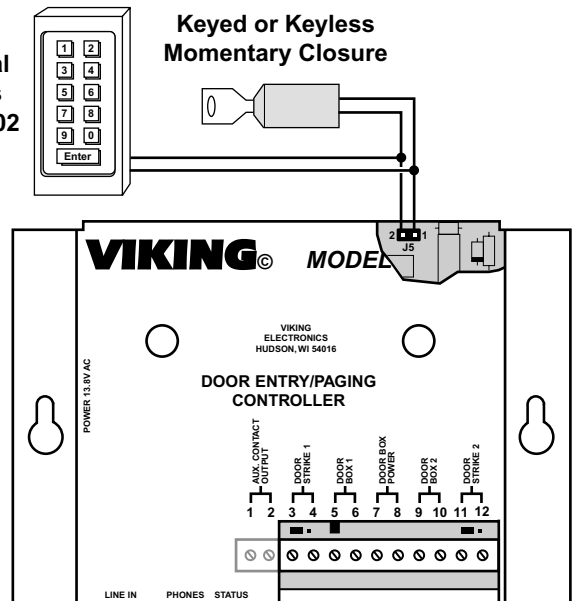

### E. Using the C-1000A to trigger a Camera or Doorbell

1. Connect the camera or doorbell (not included) as shown to the right. **Note:** The **C-1000A** will not supply power to the doorbell, an adapter is necessary.
2. Connect doorboxes and doorstrike outputs (if required) as shown in sections **A**.
3. Program the **Auxiliary Contact Output** as desired (see **Programming** section **B**).
4. See **Operation** section **A**, 6. **Auxiliary Contacts**.

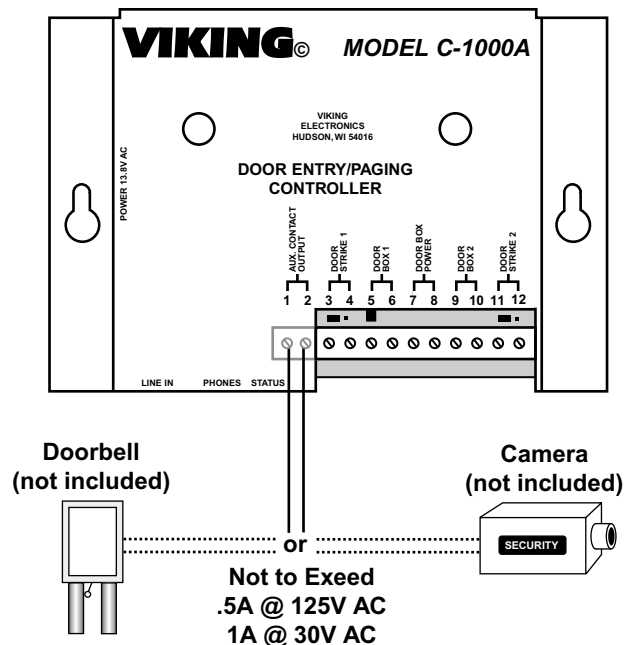

## F. Line Concentrator Mode (One Telcom Device Can Answer up to Three Lines)

The **C-1000A** can be used as a line concentrator, allowing up to 3 separate C.O. lines to connect to one telcom device.

1. Connect as shown below.
2. Move DIP switch 3 to the **OFF** position (see **Programming** section E).
3. Be sure the "Talk Battery Switch" is **OFF**.
4. See **Operation** section C.

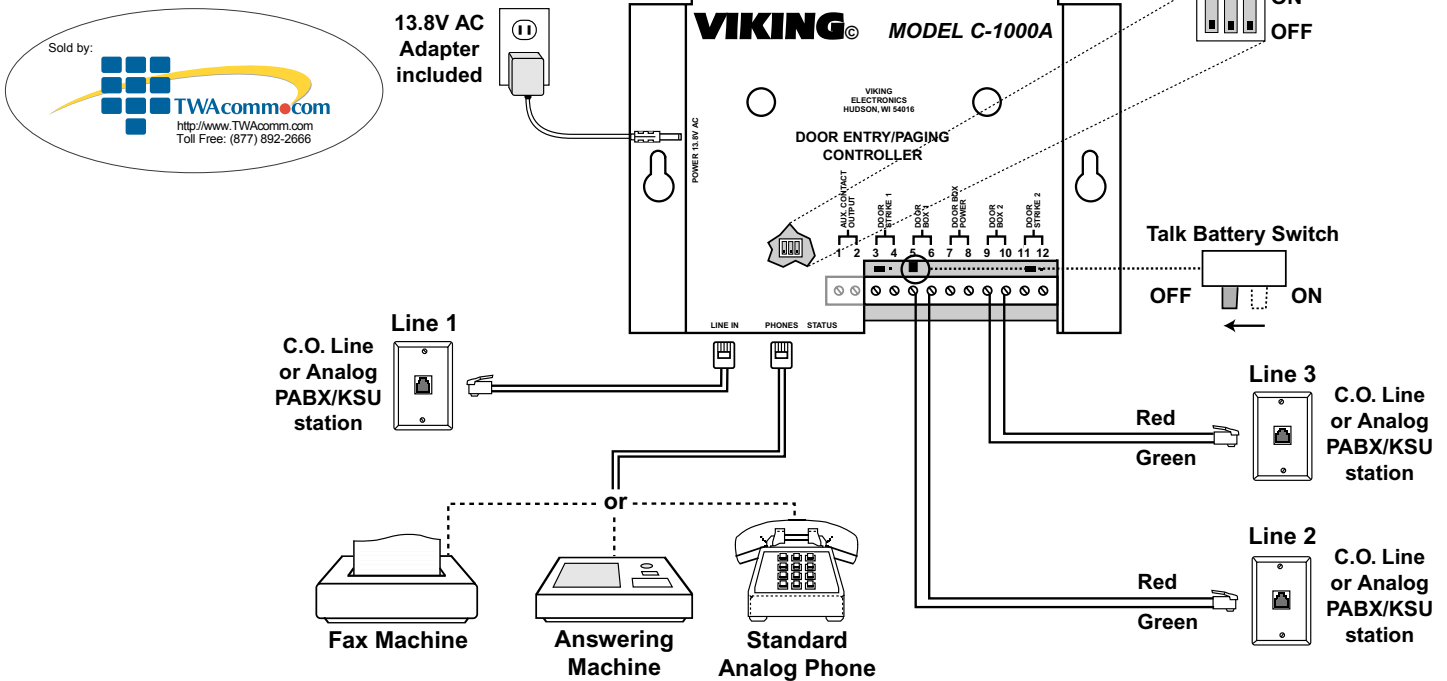

## G. Adding Paging to Homes and Small Businesses with Single Line Phones

The **C-1000A** can be used to control a paging amplifier from a single phone line. The amplifier used must provide talk battery, such as the **PA-2A** (Fax Back Document 485) or **CPA-7B** (Fax Back Document 455). If need be, a doorbox or a second paging amplifier may also be added to the **C-1000A** Doorbox 2 terminals (see **Installation** section A).

**Note:** The **C-1000A** must be programmed to be in the **Paging Mode, \*4** (see **Programming** section B and **Operation** section B).

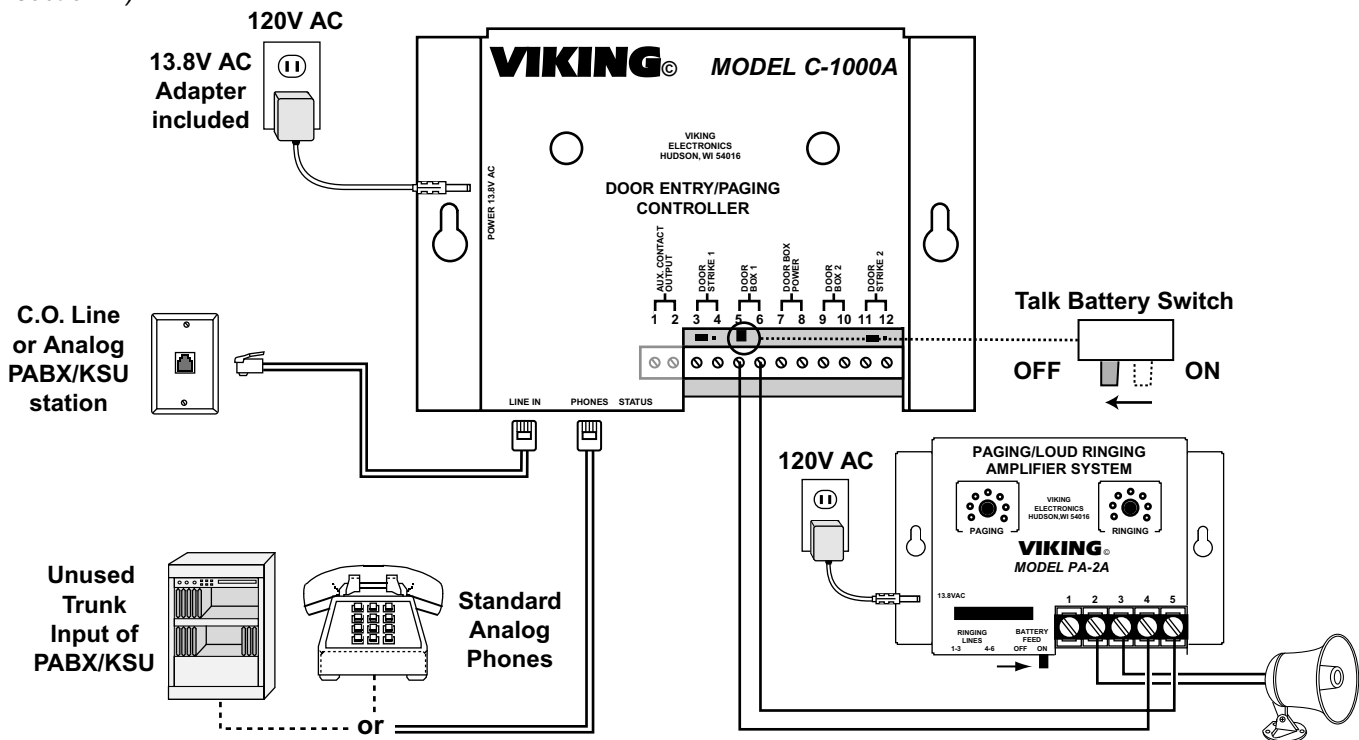

# Programming

## A. Accessing the Programming Mode

### 1. Accessing the Programming Mode Locally (Security Code Bypass Mode)

- Move DIP switch 2 from OFF to ON (see **Programming** section E).
- Call into the **C-1000A** from a Touch Tone phone. **Note:** Call in from another line to avoid C.O. busy signals, etc.
- Answer the call using the device on the "PHONES" port.
- A double beep will indicate that you have accessed the programming mode.
- You can now Touch Tone program the features listed in section **B** below.
- When finished programming, move DIP switch 2 to the OFF position.

**Note:** Programming from a cell-phone may not be suitable in areas with weak coverage.

### 2. Accessing the Programming Mode Remotely

- Call into the **C-1000A** from a Touch Tone phone. **Note:** Call in from another line to avoid C.O. busy signals, etc.
- Answer the call using the device on the "PHONES" port.
- From either phone enter \* followed by the six digit security code (see **Programming** section D).
- A double beep will indicate that you have accessed the programming mode.
- You can now Touch Tone program the features listed in section **B** below.

**Note:** Programming from a cell-phone may not be suitable in areas with weak coverage.

## B. Quick Programming Features

	Enter Digits - then -	Memory Location
Door strike 1 activation time .5 - 10 seconds (see "Note" below) .....	2 digits (00-10) +	#01
Door strike 2 activation time .5 - 10 seconds (see "Note" below) .....	2 digits (00-10) +	#02
Auxiliary contact activation time .5 - 10 seconds (see "Note" below) .....	2 digits (00-10) +	#03
<b>Note:</b> 00 = .5 seconds, 01-10 = 1-10 seconds, factory set to 00 (.5 seconds).		
Auxiliary contact latched while either doorbox is activated .....	11 +	#03
Auxiliary contact activated in custom ring cadence .....	12 +	#03
Security Code (factory set to 845464) .....	6 digits (0-9) +	#47

	Enter Digits
Disable all special modes listed below (factory default) .....	*0
Doorbell mode .....	*1
Custom ring mode .....	*2
Multiple relay activation mode .....	*3
Paging mode .....	*4
Inhibit latching commands mode .....	*6
To reset to factory settings .....	###

**Note:** Multiple modes may be selected.



## C. Programming Examples

Programming the C-1000A...	Enter
1. ...to set door strike 1 to activate for 3 seconds	03 #01
2. ...to set the auxiliary contacts to activate a camera while either doorbox is activated	11 #03
3. ...to set the auxiliary contacts to activate an external ringer or strobe light in a custom ring cadence while either doorbox is ringing	12 #03
4. ...to have doorboxes ring phones in a custom ring pattern	*2

## D. Security Code

This six digit number can be used to access the programming mode. The security code has been factory set to **845464** (V-I-K-I-N-G). It is recommended that you change the security code to a personal 6 digit number. To change the security code, access programming (see **Programming** section A). Enter six digits 0-9 followed by **#47**. If you have forgotten your security code, follow the steps in **Programming** section A, **1. Accessing the Programming Mode Locally**. **Note:** The security code must be six digits in length and can NOT contain a \* or #.

## E. Dip Switch Programming

Switch	Description	Operation
1	Doorstrike Activation Time	<b>OFF</b> - .5 seconds (factory setting) <b>ON</b> - 10 seconds
2	Security Code Bypass Mode	<b>OFF</b> - Normal Mode (factory setting) <b>ON</b> - Security Code Bypass Mode
3	Mode Selection	<b>OFF</b> - Line Concentrator Mode <b>ON</b> - Normal Operation (factory setting)

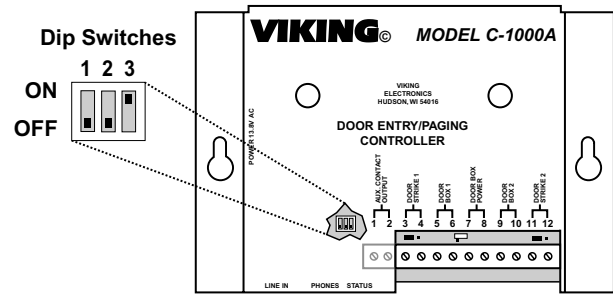

## F. Mode Descriptions

Entering these codes while in programming will switch the **C-1000A** into the corresponding mode.

**Disable Special Modes (\*0):** This command disables (clears) all the special modes listed below. Enter this command before programming the rest of the selections to be sure no unwanted modes are set.

**Doorbell Mode (\*1):** In this mode, the ring signal from either doorbox is prevented from going through to the "PHONES" port. This is useful when a conventional door bell is connected to the auxiliary contacts. Now when someone activates a doorbox, the doorbell will chime rather than the phone ringing (see **Programming** section B).

**Custom Ring Mode (\*2):** With this mode selected, the ring signal from the device ports are interrupted in a double burst pattern, making it easier to determine if the incoming call is from a doorbox or the C.O. line.

**Multiple Relay Activation Mode (\*3):** If selected, after a door strike command is entered, the phone is switched back to the doorbox port so additional doorstrike (relay activation) commands can be entered. This is useful when letting someone through your gate with the first command then unlocking your front doorstrike with a second command. To return to the call on hold, enter "#".

**Paging Mode (\*4):** In this mode a paging system that provides talk battery (**Viking PA-2A** or **CPA-7B**) can be connected to one of the doorbox ports. When the person on the phone wants to make a page, they can enter "#" and a "1" or "2" depending on which port the paging amplifier is on. After the announcement is made another "#" will return them to the phone conversation.

**Inhibit Latching Commands Mode (\*6):** In some installations it is critical that the door strike or door actuator not be turned on for long periods of time. To prevent this from happening, enter \*6 when in programming. In this mode, the toggle command (\*#) and the continuous activation command (\*1) are ignored.

## G. N.O./N.C. Contact Selection

Selection shunts are provided for each door strike relay and the auxiliary relay. Place the shunt in the left position for normally open contacts, or in the right position for normally closed contacts. These shunts are located directly above the terminal block positions that they control.

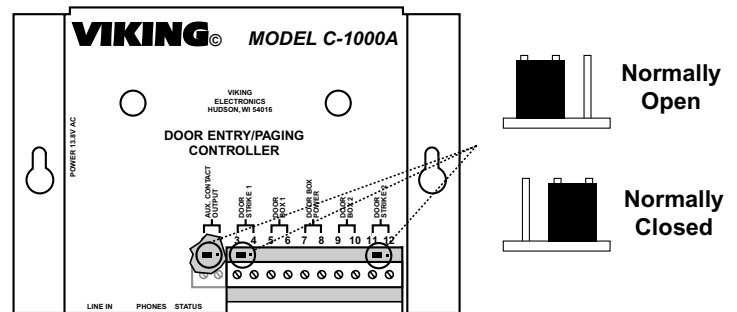

# Operation

## A. Doorbox Controller

### 1. Communicating with the Doorbox

#### a. Visitor Initiated Call

A visitor pressing the "Call" button will cause the phones connected to the "PHONES" port to ring. Simply answer your phone to converse with the visitor.

#### b. Monitoring Doorboxes

A doorbox may be monitored from any phone connected to the **C-1000A** by Touch Tone dialing a "#" followed by a Touch Tone "1" or "2" to monitor doorbox 1 or doorbox 2 respectively. This feature is not available for pulse dialing phones. **Note:** Do not attempt doorbox monitoring while a call is in progress, the call will be disconnected.

**Note:** When monitoring, the auxiliary contact will only work on the **Continuous Mode (11)**.



## 2. Placing C.O. Line Calls on Hold

If a C.O. line call is in progress and a doorbox is activated, a single or double “call waiting” tone will be heard indicating doorbox 1 or doorbox 2 is calling. To place the in-progress call on hold and answer the calling doorbox, simply dial a Touch Tone “#”, pulse dial a “2” or hook flash twice.

## 3. Activating a Doorstrike, Magnetic Lock or Gate Controller

To activate a relay contact, you must be communicating with a doorbox. Simply Touch Tone dial “\* \*”, pulse dial a “3” or hook flash three times. Two confirmation tones will be heard and the relay will be activated for the programmed doorstrike activation time. The phone will then be returned to the C.O. line. If a call was in progress, the original caller will be taken off hold to continue the conversation. To return to the original call without activating a relay, Touch Tone dial “#”, pulse dial a “2” or hook flash twice.

4. Features	Touch Tone Commands	Pulse Dial/Flash Commands
Activate doorstrike relay 1 or 2 .....	* *	Pulse dial 3 or hook flash 3 times
Continuously activate doorstrike relay 1 or 2 .....	* 1	
Continuously de-activate doorstrike relay 1 or 2 .....	* 0	
Activate opposite doorstrike relay .....	* 2	
Toggle relay from last position .....	* #	
Answer or disconnect a doorbox call .....	#	Pulse dial 2 or hook flash 2 times
Monitor doorbox 1 .....	# 1	
Monitor doorbox 2 .....	# 2	

**Note:** When on the C.O. line, if a Touch Tone other than # is entered, any additional Touch Tones in that dial string will be ignored. To regain control of the **C-1000A**, the phone must be momentarily placed on-hook.

## 5. Postal Lock/Keyless Entry

When a momentary postal lock contact closure is made across pins **JP5** (see **Installation** section **D**), the doorstrike 1 contact will activate for the programmed time.

## 6. Auxiliary Contacts

The auxiliary contacts are a separate set of contacts that can be programmed (see **Programming** section **B**) to activate in different patterns when doorbox 1 or doorbox 2 is off hook. A momentary activation, a continuous activation while the doorbox is off-hook, and a ring cadence pattern are available.

### a. Timed Activation

If an auxiliary contact activation time is programmed (two digits **00-10** followed by **#03**), when either doorbox is activated, the auxiliary contacts will activate for the programmed time (.5 - 10 seconds). This is ideal for operating a doorbell or chime.

### b. Continuous Activation

If the auxiliary contact is programmed to continuously activate (**11** followed by **#03**), while either doorbox is ringing or off-hook, the auxiliary contacts will latch. This is ideal for controlling cameras, lights, etc.

### c. Ring Cadence Activation

If the auxiliary contact is programmed to custom ring cadence (“**12 #03**”) when doorbox 1 is activated, a repeating 1 second on and 3 seconds off contact pattern is generated. If doorbox 2 is activated, a repeating double burst contact pattern is generated with 3 seconds off between patterns.

## B. Paging Controller

In this mode a paging system that provides talk battery (**Viking PA-2A** or **CPA-7B**) can be connected to one of the doorbox ports. When the person on the phone wants to make a page, they can enter “#” and a 1 or 2 depending on which port the paging amplifier is on. After the announcement is made, if a call was in progress, another “#” will return them to the phone conversation.

## C. Line Concentrator

The first ringing line will ring to the “**PHONE**” port of the **C-1000A**. On outbound calls, the **C-1000A** will default to the primary line (line connected to the “**Line In**” port). To access the lines connected to “**Doorbox 1**” port or “**Doorbox 2**” port, simply dial Touch Tones “**#1**” or “**#2**” respectively. **Note:** DIP switch 3 must be in the **OFF**



# Door Boxes



W-1000

These **Viking** doorboxes are designed to be installed on the unused telephone line input of nearly any phone system.

When the **Call** button is pressed, the doorbox generates a standard ring cadence for an adjustable number of rings. To converse with the visitor, the inside party simply answers the call from the phone of their choice. For noisy environments, the doorbox's "push-to-talk" feature may be used.

The flush mount **W-1000** doorbox is made of black powder painted aluminum and also available in a stylish brass finish. The surface mount **W-2000A** doorbox is made of UV resistant plastic. The flush mount **W-3000** doorbox is made of vandal and weather resistant stainless steel.

The **W-1000** and **W-3000** may be surface mounted using Viking's **VE-5x5** backbox. For more information on the **VE-5x5**, retrieve **Fax Back Document 424**.

For more information on the **W-1000** or **W-2000A**, retrieve **Fax Back Document 170**. For more information on the **W-3000**, retrieve **Fax Back Document 180**.



W-2000A



W-3000 with VE-5x5

# Advanced Door Entry

The **C-2000** allows up to 4 entry phones to call into your existing residential or business phones or phone system. Tenants may answer the call, converse with the visitor and activate a contact closure to control electronic gates or door strikes.

The **C-2000** provides "Caller ID," "Call Waiting ID" and "Call Waiting" tones when the phone line is in use. Tenants may gain entry at each gate by entering a Touch Tone keyless entry code.

Create an advanced door entry system by using the **C-2000** in combination with the **K-1700-3** handsfree phone.

The **K-1700-3** features a vandal and weather resistant stainless steel faceplate with a heavy duty keypad. The **K-1700-3** comes complete with a standard, flush mount, rough-in box. In addition, the **K-1700-3** may be surface mounted using Viking's **VE-6x7** backbox. For more information on the **VE-6x7**, retrieve **Fax Back Document 424**.

For more information on the **C-2000**, retrieve **Fax Back Document 156**. For more information on the **K-1700-3**, retrieve **Fax Back Document 157**.



C-2000



K-1700-3



K-1700-3 with VE-6x7

**Product Support Line...715.386.8666**

**Fax Back Line...715.386.4345**

Due to the dynamic nature of the product design, the information contained in this document is subject to change without notice. Viking Electronics, and its affiliates and/or subsidiaries assume no responsibility for errors and omissions contained in this information. Revisions of this document or new editions of it may be issued to incorporate such changes.